

## DESCRIPTION

The ULC0511CDN is a bi-directional TVS diode, utilizing leading monolithic silicon technology to provide fast response time, very low capacitance and low ESD clamping voltage, making this device an ideal solution for protecting voltage sensitive data and power line. The ULC0511CDN complies with the IEC 61000-4-2 (ESD) standard with  $\pm 15\text{kV}$  air and  $\pm 8\text{kV}$  contact discharge. It is assembled into an ultra-small 1.0x0.6x0.5mm lead-free DFN package. The small size and very low capacitance make ULC0511CDN an ideal choice to protect cell phone, digital cameras, audio players, data interface and many other portable applications.

## APPLICATIONS

- ✧ Cellular Handsets and Accessories.
- ✧ Personal Digital Assistants.
- ✧ Notebooks and Handhelds.
- ✧ Portable Instrumentation.
- ✧ Digital Cameras.
- ✧ Peripherals.
- ✧ Audio Players.
- ✧ Keypads, Side Keys, USB 2.0, LCD Displays.

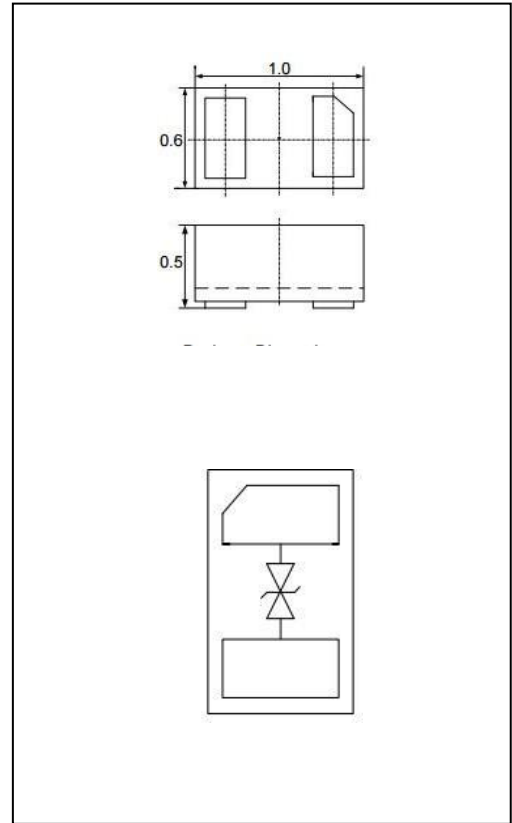

## FEATURES

- ✧ Ultra small package: 1.0x0.6x0.5mm.
- ✧ Protects one data or power line.
- ✧ Ultra low leakage: nA level.
- ✧ Working voltage: 5V.
- ✧ Low clamping voltage.
- ✧ 2-pin leadless package.
- ✧ Complies with following standards:
  - IEC 61000-4-2 (ESD) immunity test
    - Air discharge:  $\pm 15\text{kV}$
    - Contact discharge:  $\pm 8\text{kV}$ .
  - IEC61000-4-5 (Lightning) 2A (8/20 $\mu\text{s}$ ).
- ✧ RoHS Compliant.

## MECHANICAL CHARACTERISTICS

- ✧ Package: DFN1006-2 (1.0x0.6x0.5mm)
- ✧ Lead Finish: NiPdAu
- ✧ Case Material: "Green" Molding Compound.
- ✧ UL Flammability Classification Rating 94V-0
- ✧ Moisture Sensitivity: Level 3 per J-STD-020
- ✧ Terminal Connections: See Diagram Below
- ✧ Marking Information: See Below DFN1006-2(0402) Package.
  - ✧ Tape & Reel : 10,000pcs.
  - ✧ Reel Size : 7 inch.

**DEVICE CHARACTERISTICS**

<b>Absolute Maximum Ratings (T<sub>A</sub>=25°C unless otherwise specified)</b>			
Parameter	Symbol	Value	Unit
ESD per IEC 61000-4-2 (Air)	VESD	±15	kV
ESD per IEC 61000-4-2 (Contact)		±8	
Operating Temperature Range	T <sub>J</sub>	-55 to +125	°C
Storage Temperature Range	T <sub>stg</sub>	-55 to +150	°C

**ELECTRICAL CHARACTERISTICS(T<sub>A</sub>=25°C unless otherwise specified)**

Parameter	Symbol	Test Condition	Min	Typ	Max	Unit
Reverse Working Voltage	V <sub>RWM</sub>			5.0	V	
Breakdown Voltage	V <sub>BR</sub>	6			V	I <sub>T</sub> = 1mA
Reverse Leakage Current	I <sub>R</sub>			0.2	μA	V <sub>RWM</sub> = 5.0 V
Clamping Voltage	V <sub>C</sub>			10	V	I <sub>PP</sub> = 1A (8 x 20μs pulse)
Junction Capacitance	C <sub>J</sub>		2.5	3	pF	V <sub>R</sub> = 0V, f = 1MHz

**ELECTRICAL PARAMETER**

Symbol	Parameter
I <sub>T</sub>	Test Current
I <sub>PP</sub>	Maximum Reverse Peak Pulse Current
V <sub>C</sub>	Clamping Voltage @I <sub>PP</sub>

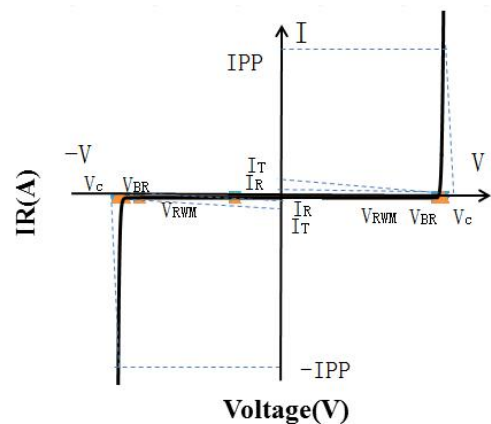

**TYPICAL CHARACTERISTICS**( $T_A=25^{\circ}\text{C}$  unless otherwise Specified)

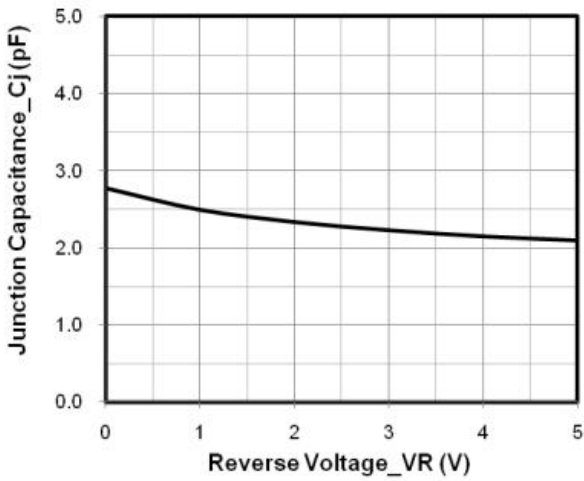

**Junction Capacitance vs. Reverse Voltage**

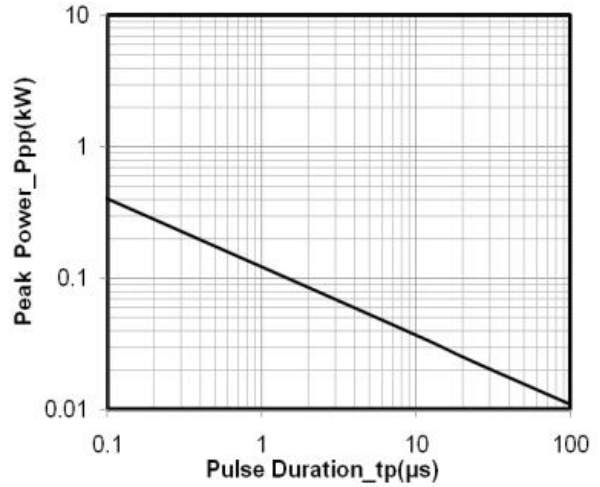

**Peak Pulse Power vs. Pulse Time**

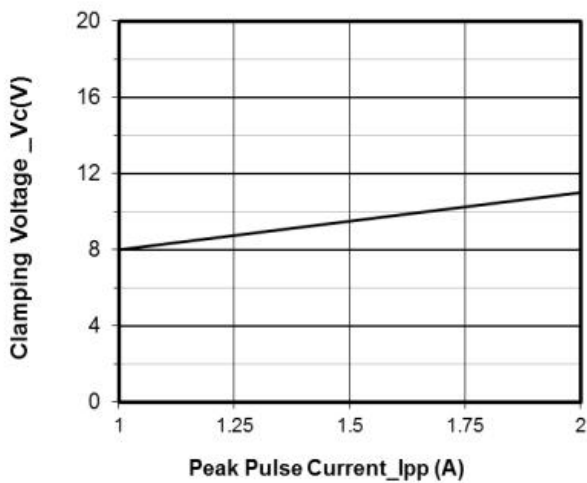

**Clamping Voltage vs. Peak Pulse Current ( $t_p = 8/20\mu\text{s}$ )**

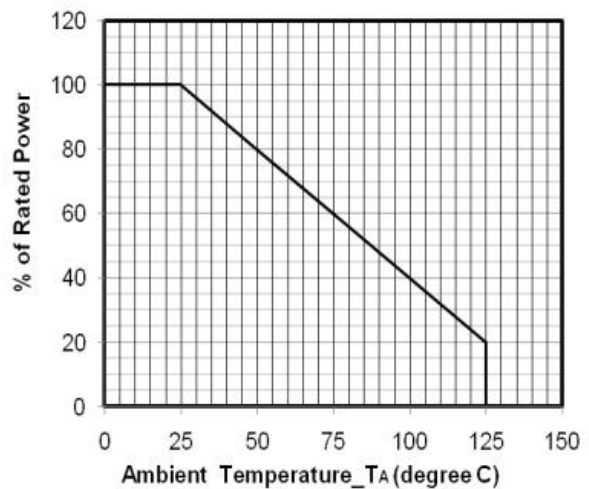

**Power Derating Curve**

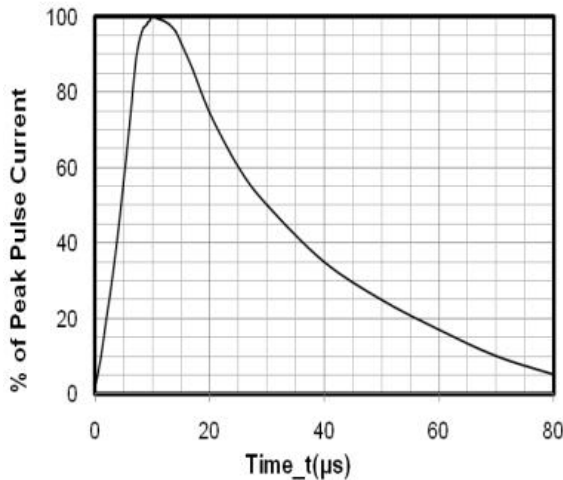

**8 X 20 $\mu\text{s}$  Pulse Waveform**

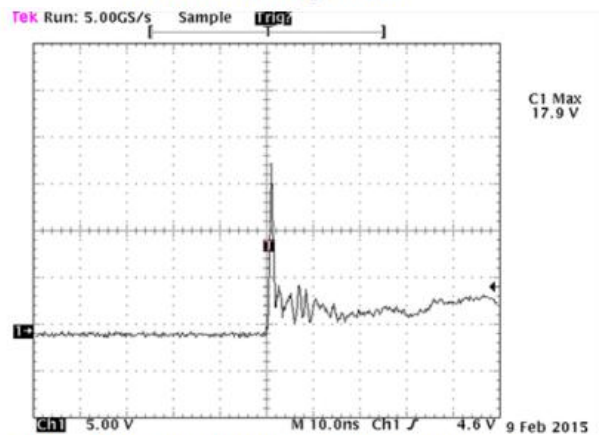

**Note: Data is taken with a 10x attenuator**

**ESD Clamping Voltage**

**+8 kV Contact per IEC61000-4-2**

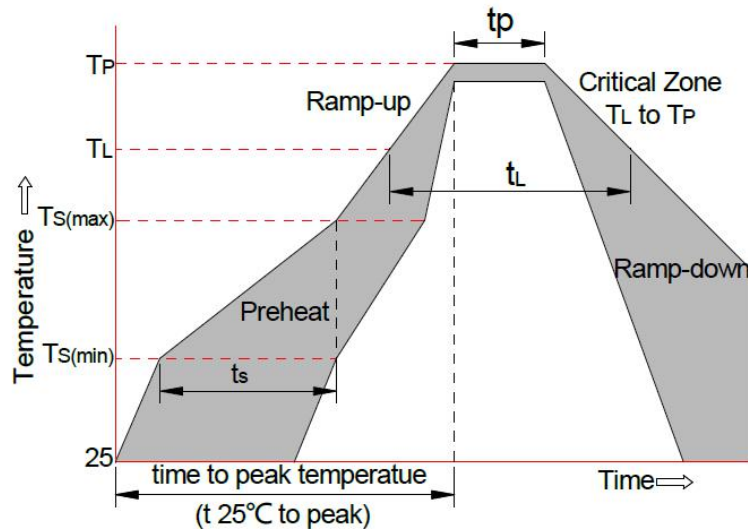
**SOLDERING PARAMETERS**

Reflow Condition		Pb-Free assembly (see FIG.5)
Pre Heat t	-Temperature Min ( $T_{s(min)}$ )	+150°C
	-Temperature Max( $T_{s(max)}$ )	+200°C
	-Time (Min to Max) ( $t_s$ )	60-180 secs.
Average ramp up rate (Liquid us Temp ( $T_L$ ) to peak)		3°C/sec. Max
$T_{s(max)}$ to $T_L$ - Ramp-up Rate		3°C/sec. Max
Reflow	-Temperature( $T_L$ )(Liquid us)	+217°C
	-Temperature( $t_L$ )	60-150 secs.
Peak Temp ( $T_p$ )		+260(+0/-5)°C
Time within 5°C of actual Peak Temp ( $t_p$ )		30 secs. Max
Ramp-down Rate		6°C/sec. Max
xTime 25°C to Peak Temp ( $T_p$ )		8 min. Max
Do not exceed		+260°C

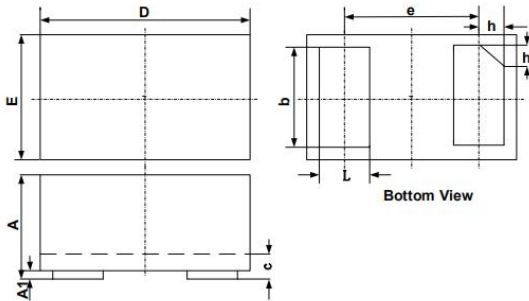
**DFN1006-2(0402) PACKAGE OUTLINE & DIMENSIONS**

SYM	DIMENSIONS					
	MILLIMETERS			INCHES		
	MIN	NOM	MAX	MIN	NOM	MAX
A	0.45	0.50	0.55	0.018	0.020	0.022
A1	0.00	0.02	0.05	0.000	0.001	0.002
b	0.45	0.50	0.55	0.018	0.020	0.022
c	0.12	0.15	0.18	0.005	0.006	0.007
D	0.95	1.00	1.05	0.037	0.039	0.041
e	0.65 BSC			0.026 BSC		
E	0.55	0.60	0.65	0.022	0.024	0.026
L	0.20	0.25	0.30	0.008	0.010	0.012
h	0.07	0.12	0.17	0.003	0.005	0.007

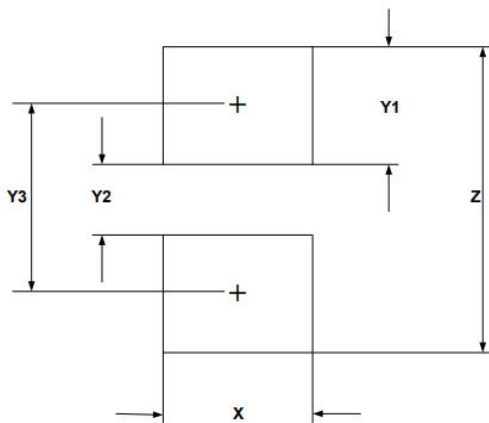
**SUGGESTED LAND PATTERN**

SYM	DIMENSIONS	
	MILLIMETERS	INCHES
X	0.60	0.024
Y1	0.50	0.020
Y2	0.30	0.012
Y3	0.80	0.032
Z	1.30	0.052

 Website: <http://www.jksemi.com>

For additional information, please contact your local Sales Representative.

©Copyright 2016, jksemi