

THINKING ELECTRONIC INDUSTRIAL CO., LTD.

HEAD OFFICE: 12F, No.93, Dashun 1st Rd., Zuoying Dist., Kaohsiung, Taiwan

TEL: 886-7-5577660 FAX: 886-7-5570560

MANUFACTURING SITE

- KAOHSIUNG FACTORY 1: No. 51, Kaifa Rd., N.E.P.Z, Kaohsiung City 81170, Taiwan
TEL: 886-7-9616668 FAX: 886-7-9616698
- KAOHSIUNG FACTORY 2: No. 2-2, Xinjian S. Rd., N.E.P.Z., Kaohsiung City 81170, Taiwan
TEL: 886-7-9630001 FAX: 886-7-3635113
- CHANGZHOU FACTORY: No.6 Longmen Rd., Wujin High & New-Tech Industrial
Development Zone, Changzhou, Jiangsu, China 213161
TEL: 86-519-86578999 FAX: 86-519-86558643
- DONG GUAN FACTORY: No.45, East Rd., Sha-Tao Dist., Chang-An Town,
Dongguan City, Guangdong, China 523863
TEL: 86-769-85542016 FAX: 86-769-85546890
- YICHANG FACTORY: No. 283 Xiaoting Avenue, Xiaoting Dist., Yichang
City 443007, Hubei, China
TEL: 86-717-6510010 FAX: 86-717-6511430



SPECIFICATION FOR APPROVAL

CUSTOMER	立創電子
CERTIFIED MODEL/TYPE	TPM0S102P125
PART NO.	TPM0S102P125RT (RoHS+HF)
APPLICATION	
CUSTOMER P/N	
ISSUE DATE	Dec. 02, 2020
REV. NO.	
REV. DATE	

FOR CUSTOMER APPROVAL	CHECKED BY
	<i>Shu Ling Fu</i>
	APPROVED BY
	<i>Chun Chu Tu</i>





REVISED RECORD SHEET

REV. NO	REV. DATE	REVISED CONTENT



INDEX	Page
■ Part Number Code	1
■ Structure and Dimensions	2
■ Electrical Characteristics	2
■ Reliability	3
■ Soldering Recommendation	4
■ Recommended Soldering Pad Dimensions	5
■ RoHS Compliant Declaration	5
■ Warehouse Storage Conditions of Products	5
■ Packaging	6
■ Safety Approvals & Certificates & Test Report	7
■ R-T Characteristic Curve	8

Part Number Code

Example :

TPM **0** **S** **102** **P** **125** **R** **T**
 (1) (2) (3) (4) (5) (6) (7) (8)

No.	Item	Digit	Specification
(1)	Product Type	TPM	Thinking CPTC thermistor TPM type
(2)	Size (EIA)	0	0402
(3)	Type Series	S	Sensing series
(4)	Zero Power Resistance at 25°C	102	$10 \times 10^2 = 1K\Omega$
(5)	Tolerance of R_{25}	P	$\pm 50\%$
(6)	Sensing Temperature	125	$T_s = 125^\circ\text{C}$
(7)	Packaging	R	Reel
(8)	Optional Suffix	T	Dual Sensing Temperature Product

Structure and Dimensions

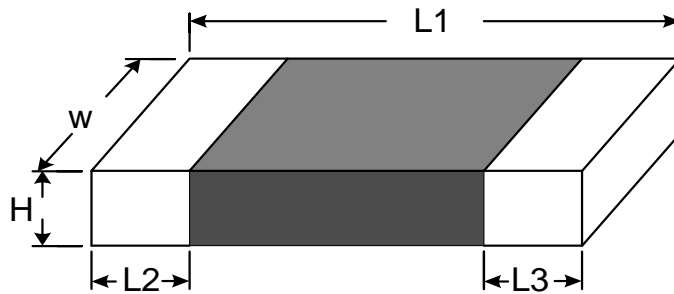

(unit : mm)

L1	W	H max.	L2 and L3
1.00±0.15	0.50±0.10	0.60	0.20±0.10

Electrical Characteristics

Part No.	Zero Power Resistance at 25°C	Sensing Temp.1 @ 10KΩ	Sensing Temp.2 @ 100KΩ	Max. Voltage	Operating Temperature Range
	R ₂₅ (KΩ)	Ts1 (°C)	Ts2 (°C)	Vmax. (V _{DC})	(°C)
TPM0S102P125RT	1±50%	125±5	140±3	32	-40 ~ +150

Reliability

Item	Standard	Test conditions / Methods	Specifications															
Bending Strength	IEC60068-2-21	Warp : 2mm ; Speed < 0.5mm/sec. Duration : 10 sec on PCB. 	No visible damage $ \Delta R_{25}/R_{25} \leq 10\%$															
Damp Heat, Steady State	IEC 60068-2-78	85 ± 3 °C , 80 ~ 85% RH , 1000± 24 hrs	No visible damage $ \Delta R_{25}/R_{25} \leq 20\%$															
High Temp. Storage	IEC 60068-2-2	150± 5 °C , 1000 ± 24 hrs	No visible damage $ \Delta R_{25}/R_{25} \leq 20\%$															
Low Temp. Storage	IEC 60068-2-1	-40± 3 °C , 1000 ± 24 hrs	No visible damage $ \Delta R_{25}/R_{25} \leq 20\%$															
Rapid Change of Temperature	IEC 60068-2-14	The conditions shown below shall be repeated 5 cycles on PCB <table border="1" data-bbox="523 974 1168 1288"> <thead> <tr> <th>Step</th> <th>Temperature (°C)</th> <th>Period (minutes)</th> </tr> </thead> <tbody> <tr> <td>1</td> <td>-25± 5</td> <td>30 ± 3</td> </tr> <tr> <td>2</td> <td>Room temperature</td> <td>5 ± 3</td> </tr> <tr> <td>3</td> <td>150± 5</td> <td>30 ± 3</td> </tr> <tr> <td>4</td> <td>Room temperature</td> <td>5 ± 3</td> </tr> </tbody> </table>	Step	Temperature (°C)	Period (minutes)	1	-25± 5	30 ± 3	2	Room temperature	5 ± 3	3	150± 5	30 ± 3	4	Room temperature	5 ± 3	No visible damage $ \Delta R_{25}/R_{25} \leq 20\%$
Step	Temperature (°C)	Period (minutes)																
1	-25± 5	30 ± 3																
2	Room temperature	5 ± 3																
3	150± 5	30 ± 3																
4	Room temperature	5 ± 3																
High Temp. Load	IEC 60738-1 7.24.3	85 ± 5 °C , Vmax. , 1000 ± 24 hrs	No visible damage $ \Delta R_{25}/R_{25} \leq 20\%$															
Climatic Sequence	IEC 60738-1 7.22	a. T _U x 16 hrs b. 1st cycle : 40 °C 95 %RH x 24 hrs c. T _L x 2 hrs d. 5 cycles : 40°C 95% RH x 24 hrs / Cycle	No visible damage $ \Delta R_{25}/R_{25} \leq 20\%$															
Solderability	IEC 60068-2-58	245 ± 5 °C , 3 ± 0.3 sec	At least 95% of terminal electrode is covered by new solder															
Resistance to Soldering Heat	IEC 60068-2-58	8.1.2.2 Solder reflow method Preheating: 150~180°C ,60~120 secs. Peak temp.: 245~255°C , ≤20 secs. (reflow)	No visible damage $ \Delta R_{25}/R_{25} \leq 20\%$															

Note: T_L = Minimum operating temperature (°C)

T_U = Maximum operating temperature (°C)

Soldering Recommendation

■ IR-Reflow Soldering Profile

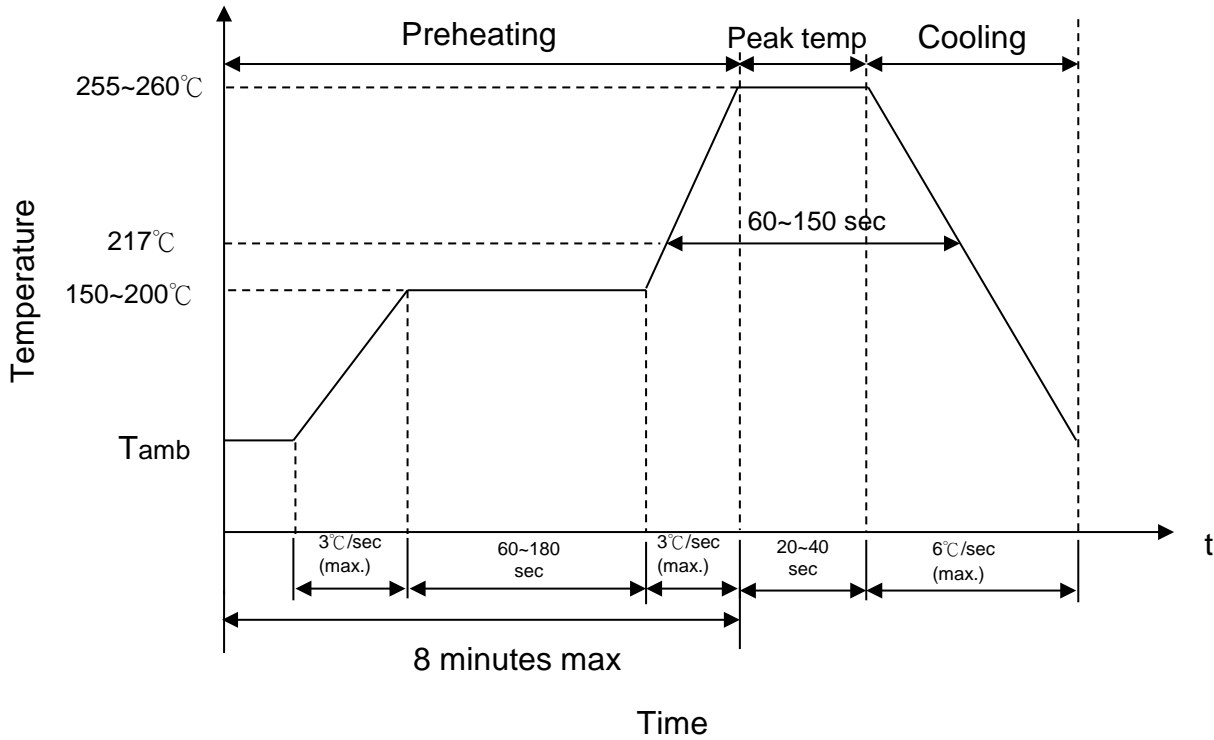

■ Recommended Reworking Conditions with Soldering Iron

Item	Conditions
Temperature of Soldering Iron-tip	360°C (max.)
Soldering Time	3 sec (max.)
Diameter of Soldering Iron-tip	φ 3mm (max.)
Caution: Not to touch the component surface with soldering iron directly to prevent component damage.	

Recommended Soldering Pad Dimensions

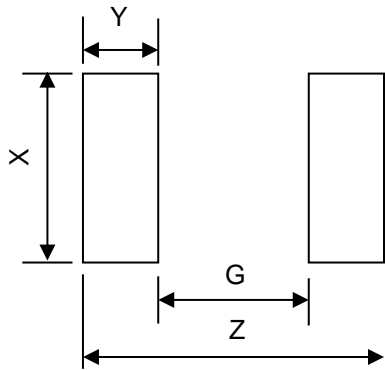

Size (EIA)	0402
Z	1.7 mm
G	0.5 mm
X	0.6 mm
Y	0.6 mm

RoHS Compliant Declaration

We hereby declare that the components delivered to your company are compliant with RoHS directive 2015/863/EU.

Warehouse Storage Conditions of Products

(I) Storage Conditions :

- 1.Storage Temperature : -10°C ~+40°C
- 2.Relative Humidity : $\leq 75\%RH$
- 3.Keep away from corrosive atmosphere and sunlight.

(II) Period of Storage : 1 year

Packaging

■ Taping Specification (0402 Series)

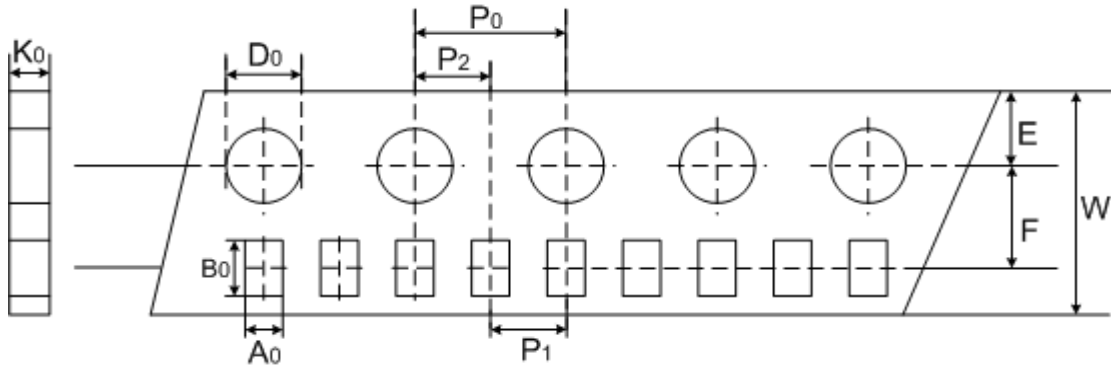

(Unit : mm)

Index	A_0	B_0	W	E	F	P_1	P_2	P_0	D_0	K_0
Size	± 0.05	± 0.12	± 0.2	± 0.1	± 0.05	± 0.1	± 0.05	± 0.1	± 0.1	± 0.1
0402	0.62	1.12	8.0	1.75	3.5	2.0	2.0	4.0	1.55	0.60

■ Quantity (10000 pcs / reel)

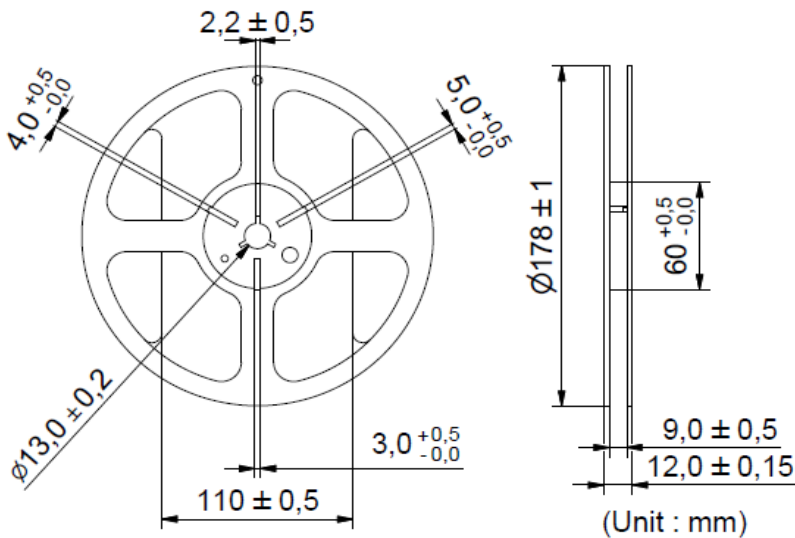

(Unit : mm)

Safety Approvals (Certified Model/Type : TPM0S102P125)



* UL 1434 / cUL recognized (File # E138827)

Certificates

- (1) IATF 16949 certificate
- (2) ISO 9001 certificate
- (3) QC 080000 certificate

Test Report

- (1) RoHS test report
- (2) Halogen-free test report

R-T Characteristic Curve

TPM0S102P125RT

