

| REV | MARK | DESCRIPTION | DRAFTED. BY | DATE |
|-----|------|-------------|-------------|------|
| | | | | |
| | | | | |
| | | | | |

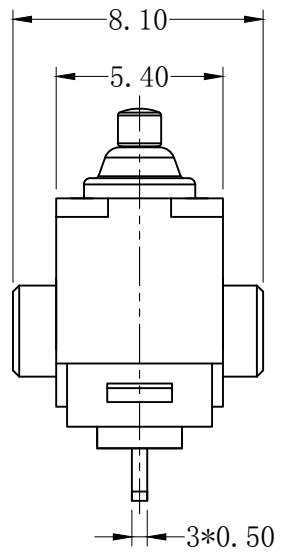
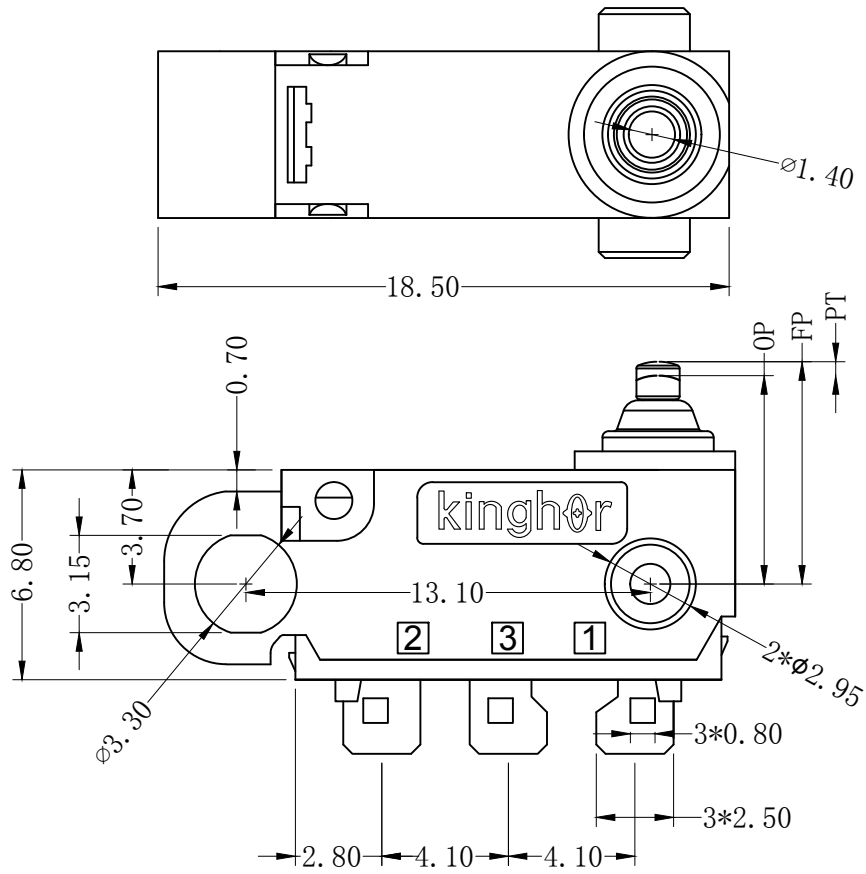

| CHARACTERISTICS | |
|-----------------------|----------------|
| OPERATING FORCE (OF): | 130gf Max. |
| RELEASE FORCE (RF): | 13gf Min. |
| OPERATING POSITION: | 6.75 ± 0.2 mm. |
| PRE TRAVEL: | 0.80mm Max. |
| DIFFERENTIAL TRAVEL: | 0.20mm Max. |
| FREE POSITION: | 7.35mm Max. |

| ELECTRICAL DATA | |
|-----------------------|-----------------------|
| RATING | OPERATING LIFE |
| 3A 12VDC | 100,000 CYCLES |
| 0.1A 48VDC 125/250VAC | 100,000 CYCLES |

| | |
|------------------------|-----------------------|
| MECHANICAL LIFE | 500,000 CYCLES |
| GAP TYPE | MICRO |
| OPERATING TEMP | -40°C ~ +85°C |
| WATERPROOF | IP67 |

| OUTLINE DRAWING | | | |
|--------------------|-------------------------------|-------------|-----------|
| TITLE | H3 SERIES MICRO SWITCH | | |
| MODEL | H3-B2 | | |
| PART NO. | H3-B2-1D00S | | |
| DRAFTED BY | Bing Wang | DATE | 2020-6-13 |
| CHECKED BY | Hua Bai | DATE | 2020-6-13 |
| APPROVED BY | Hong Chen | DATE | 2020-6-13 |

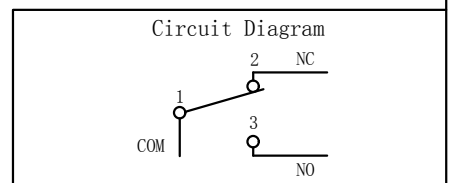

| TOLERANCE UNLESS OTHERWISE SPECIFIED | | | | | | | |
|--------------------------------------|------|------|-------|--------|---------|-------|--|
| ≤3 | 1~3 | 3~10 | 10~30 | 30~100 | 100~200 | ANGLE | |
| ±0.2 | ±0.3 | ±0.4 | ±0.6 | ±1.0 | ±1.5 | ±3.0° | |

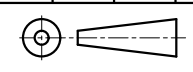

| SCALE | |
|-------------|----|
| UNIT | mm |
| VERSION REV | A1 |

KINGHOR
SWITCHES AND CONTROL EXPERT