

Ordering Information:

C4201WVA-F-2xXP - \*\* - \*\* - \*\*  
 1 2 3 4

- 1.Part No.
- 22.Material:  
 (blank);Nylon 66 UL94V-2  
 V0:Nylon 66 UL94V-0  
 GWT:Nylon 66 UL94V-0,GWT 750°C
- 3.Color:  
 (blank);Natural  
 WH:White  
 BK:Black  
 RD:Red  
 YL:Yellow  
 BL:Blue
- 4.Finish:  
 (blank);Tin over Nickel  
 G:Gold over Nickel(1u")  
 G3:Gold over Nickel(3u")  
 G15:Gold over Nickel(15u")  
 G30:Gold over Nickel(30u")

P.C.B LAYOUT

SPECIFICATIONS:

Current Rating: 9A AC,DC  
 Voltage Rating: 600V AC,DC  
 Temperature Range: -40°C ~ +105°C  
 Contact Resistance: 10mΩ Max  
 Insulation Resistance: 1000MΩ Min  
 Withstanding Voltage: 1500V AC/minute  
 Pin Material: Brass/Tin over Nickel  
 Material: Nylon 66,UL94V-2(Natural)

Ordering Information & Dimensions

Circuits	Dimensions(mm)		Circuits	Dimensions(mm)	
	A	B		A	B
2x1P	---	5.40	2x8P	29.40	34.80
2x2P	4.20	9.60	2x9P	33.60	39.00
2x3P	8.40	13.80	2x10P	37.80	43.20
2x4P	12.60	18.00	2x11P	42.00	47.40
2x5P	16.80	22.20	2x12P	46.20	51.60
2x6P	21.00	26.40	2x18P	71.40	76.80
2x7P	25.20	30.60			

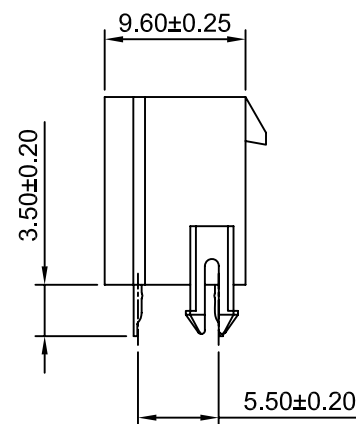
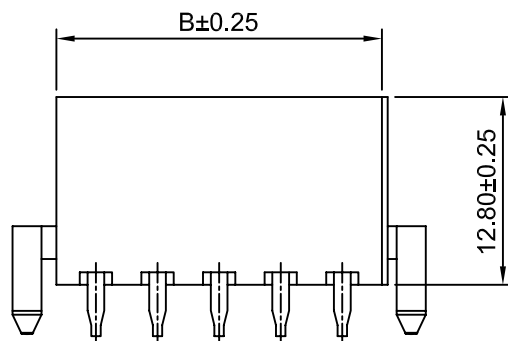

**CJTconn**

CHANGJIANG CONNECTORS CO.,LTD.

Unit	Scale	Sheet
mm	2:1	1 of 1
Draw BY:	Approved :	
LIZQ	GONGYB	

Title :  
**4.20mm PITCH**  
**180° DUAL ROW WAFER**

A0	NEW RELEASE	2005.05.10
REV	DESCRIPTION	DATE

General Tolerance	
x.x≤0.25	ANGLE±
x.xx≤0.20	
x.xxx≤0.15	

DRAW NO : C4201WVA-F-2xXP      REV A0