

Features

- Ultra low capacitance: 0.35pF Max
- Ultra low leakage: nA level
- Low operating voltage: 5V
- Low clamping voltage
- 2-pin leadless package
- Complies with following standards:
 - – IEC 61000-4-2 (ESD) immunity test
 - Air discharge: $\pm 20\text{kV}$
 - Contact discharge: $\pm 15\text{kV}$
 - – IEC61000-4-5 (Lightning)4A (8/20 μs)
- RoHS Compliant
- Lead Finish: NiPdAu

Mechanical Characteristics

- Package: SOT-523
- Lead Finish: Matte Tin
- Case Material: "Green" Molding Compound.
- Moisture Sensitivity: Level 3 per J-STD-020
- Terminal Connections: See Diagram Below

Applications

- ◆ Cellular Handsets and Accessories
- ◆ Notebooks and Handhelds
- ◆ Portable Instrumentation
- ◆ Set Top Box
- ◆ Industrial Controls

Ordering Information

Part Number	Qty per Reel	Reel Size
TPESD0502BA	3000	7"

Dimensions and Pin Configuration

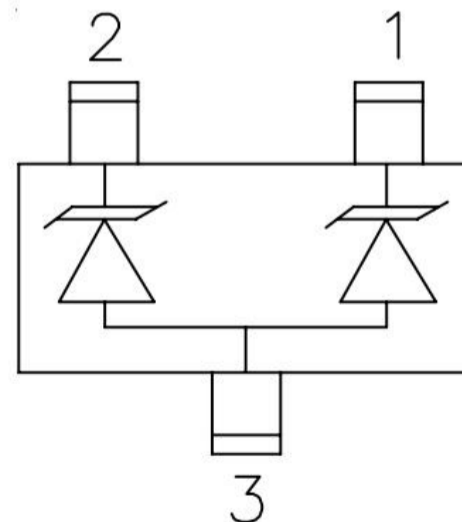
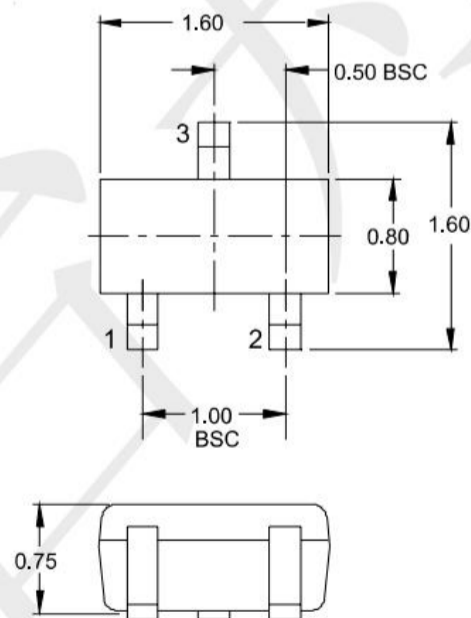

Absolute Maximum Ratings (Tamb=25°C unless otherwise specified)

Parameter	Symbol	Value	Unit
Peak Pulse Power (8/20μs)	Ppk	80	W
Peak Pulse Current (8/20μs)	Ipp	4	A
ESD per IEC 61000-4-2 (Air) ESD per IEC 61000-4-2 (Contact)	VESD	±20 ±15	kV
Operating Temperature Range	TJ	-55 to +125	°C
Storage Temperature Range	Tstg	-55 to +150	°C

Electrical Characteristics (TA=25°C unless otherwise specified)

Parameter	Symbol	Min	Typ	Max	Unit	Test Condition
Reverse Working Voltage	VRWM			5	V	
Breakdown Voltage	VBR	6	7.5	8.5	V	IT = 1mA
Reverse Leakage Current	IR			0.07	μA	VRWM = 5V
Clamping Voltage	VC			9	V	I _{PP} = 1A (8 x 20μs pulse)
Clamping Voltage	VC			15	V	I _{PP} = 4A (8 x 20us pulse)
Junction Capacitance	CJ		0.5	0.6	pF	VR = 0V, f = 1MHz, any I/O pin to ground
			0.25	0.35	pF	VR = 0V, f = 1MHz, between I/O pins

Typical Performance Characteristics ($T_A=25^\circ\text{C}$ unless otherwise Specified)

Fig1. 8/20 μs Pulse Waveform

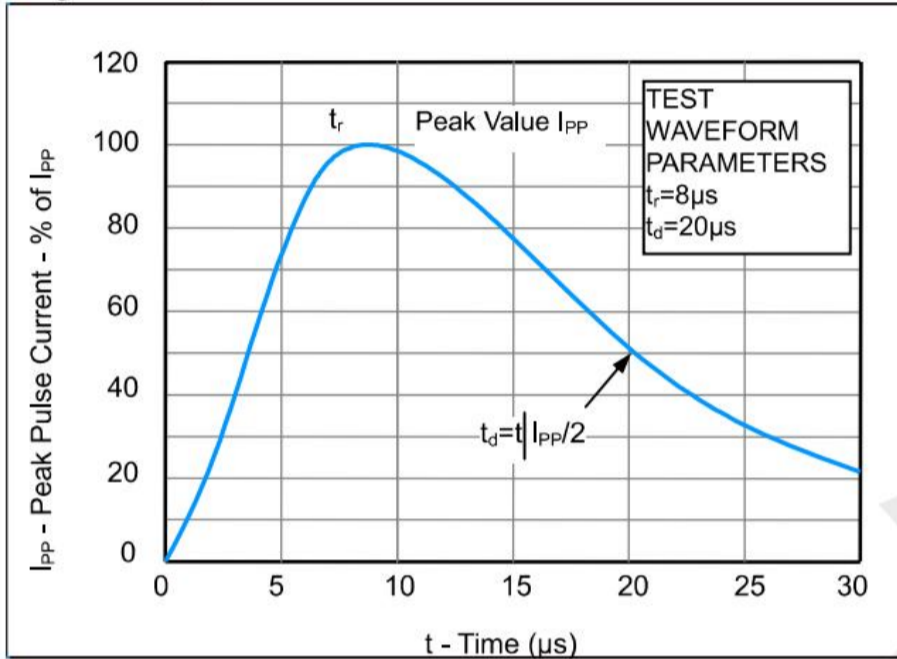

Fig2. ESD Pulse Waveform (according to IEC 61000-4-2)

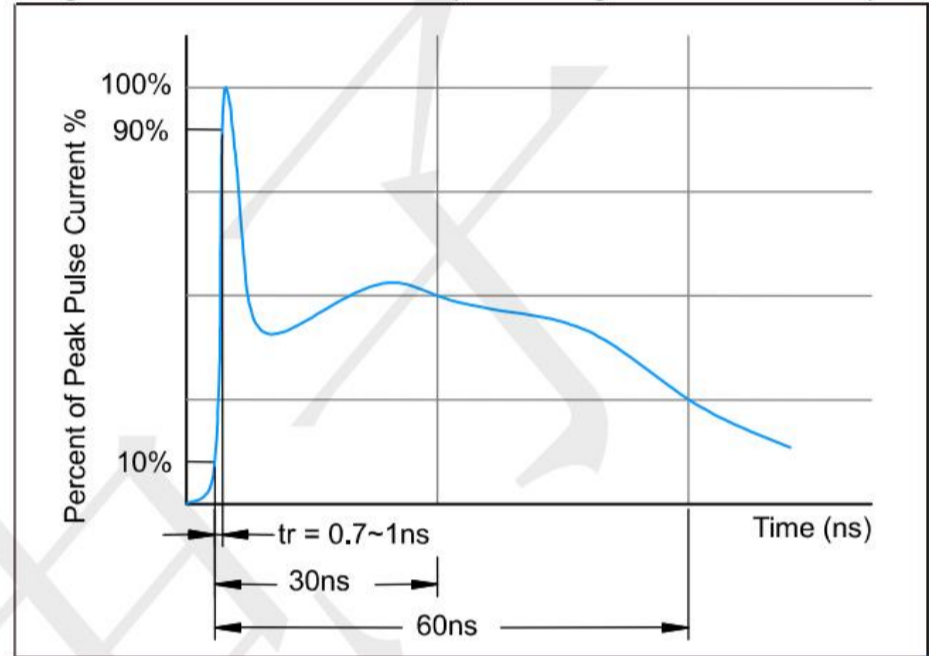
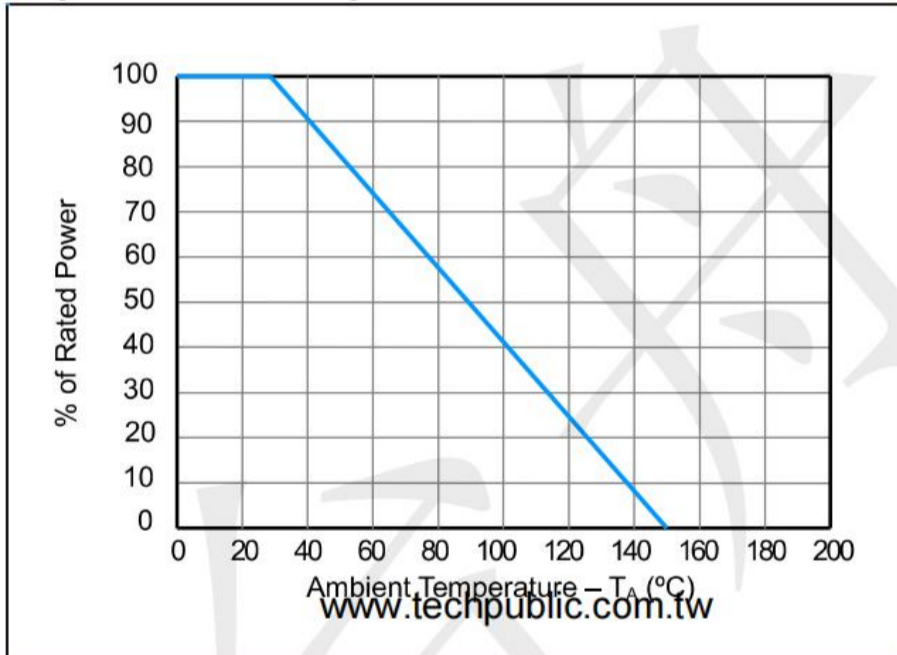
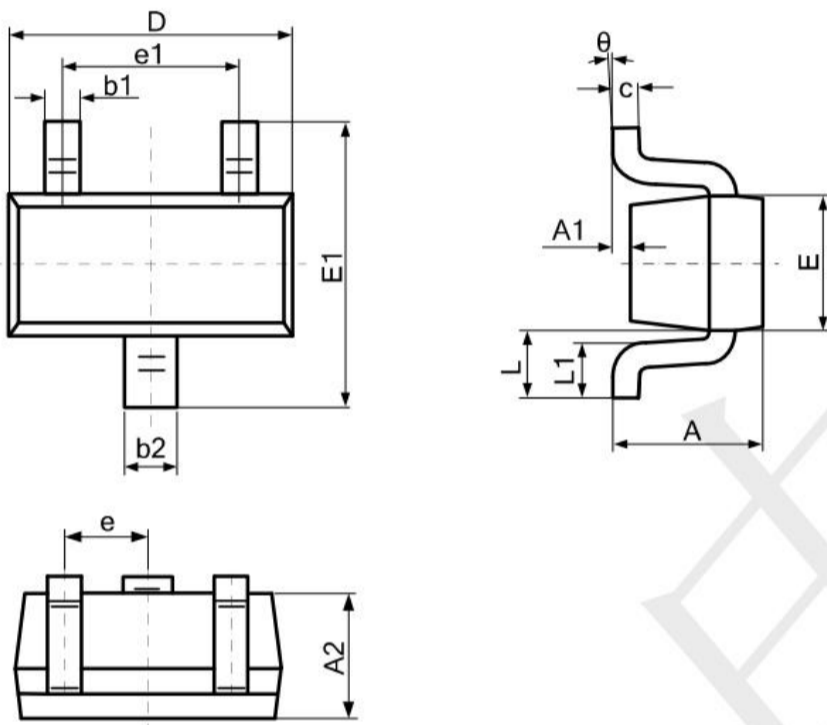

Fig3. Power Derating Curve



Outline Drawing - SOT-523



SYMBOL	DIMENSIONS			
	MILLIMETER		INCHES	
	MIN	MAX	MIN	MAX
A	0.700	0.900	0.028	0.035
A1	0.000	0.100	0.000	0.004
A2	0.700	0.800	0.028	0.031
b1	0.150	0.250	0.006	0.010
b2	0.250	0.325	0.010	0.013
c	0.100	0.200	0.004	0.008
D	1.500	1.700	0.059	0.067
E	0.750	0.850	0.030	0.033
E1	1.450	1.750	0.057	0.069
e	0.950 BSC		0.037 BSC	
e1	0.900	1.100	0.035	0.043
L	0.300	0.500	0.012	0.020
L1	0.028	0.440	0.011	0.017
θ	0	8°	0	8°

Land Pattern - SOT-523

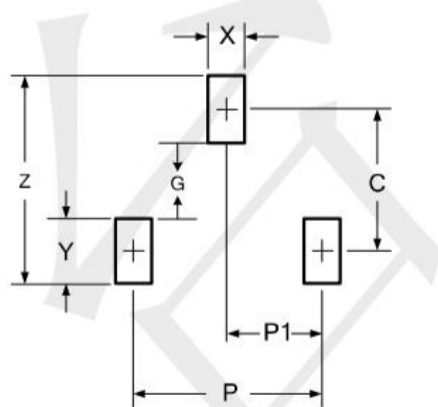

DIM	DIMENSIONS	
	INCHES	MILLIMETERS
C	.055	1.40
P	.039	1.00
P1	.020	0.50
G	.024	0.60
X	.016	0.40
Y	.031	0.80
Z	.087	2.20