



Film Capacitors

Metallized Polypropylene Film Capacitor

Series/Type: B32641B
Ordering code: B32641A0333J501
Date: 2018-07-19
Version: b

© EPCOS AG 2018. Reproduction, publication and dissemination of this publication, enclosures hereto and the information contained therein without EPCOS' prior express consent is prohibited.

EPCOS AG is a TDK Group Company.

Automotive Customer: HANG ZHOU EV-TECH CO.,LTD

Applications

- Electronic ballasts (resonant circuits)
- LLC typology in resonant circuits
- High frequency applications with high current stress
- SMPS

Climatic

- Max. operating temperature: 110 °C
- Climatic category (IEC 60068-1): 40/110/56

Construction

- Polypropylene(PP) dielectric with double side metallized polyester(PET) film as electrodes
- Wound capacitor technology
- Plastic case (UL 94 V-0)
- Epoxy resin sealing

Features

- Very compact design
- High pulse strength
- High current withstand capability

Terminals

- Parallel wire leads
- lead-free tinned

Marking

- Manufacturer's logo
- Lot number, series number
- Rated capacitance (coded)
- Capacitance Tolerance (code letter)
- Rated DC voltage
- Date of manufacture (coded)

Delivery mode

- Reel packing
- MOQ: 8×PU (8×800pcs)

Drawing

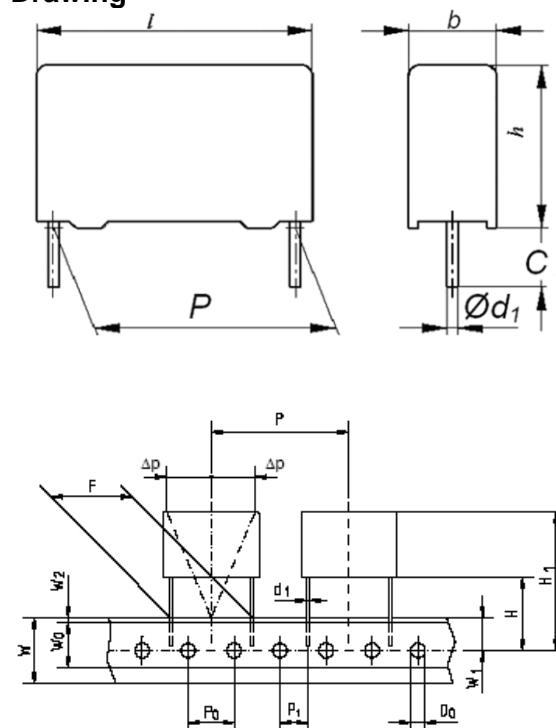

Dimensions

- Lead spacing (P): 10.0 ± 0.4 mm
- Width max. (b): 8.5 mm
- Height max. (h): 17.5 mm
- Length max. (l): 13.0 mm
- Lead diameter (Ød1): 0.6 ± 0.05 mm
- H: 18.5 ± 0.5 mm
- P0: 12.7 ± 0.2 mm

Technical data

Reference: IEC60384-16: 2005. All data given at T = 20 °C, unless otherwise specified.

Rated Temperature	85°C		
Operation temperature range: $T_{max}^{op} = T_{amb} + T_{self-heating}$	Upper Category Temperature	T_{max}	+110 °C
	Maximum Operating Temperature	T_{max}^{op}	+110 °C
	Lower Category Temperature	T_{min}	-55 °C
Rated Capacitance C	33nF		
Capacitance tolerance	± 5 % (J)		
Continuous operating voltage / Rated Voltage $V_{R,DC}$ Rated Voltage $V_{R,AC}$	1000 V DC @ 85°C 500 V AC @85°C		
Dissipation factor $\tan \delta$ (in 10^{-3}) at 20 °C (upper limit values)	0.6 (at 1 kHz) 1.5 (at 100kHz)		
Category voltage V_C (continuous operation with V_{DC} or V_{AC} at $f \leq 1$ KHz)	T_{op} (°C)	DC voltage derating	
	$T_{op} \leq 85$ $85 < T_{op} \leq 110$	$V_C = V_R$ $V_C = V_R \cdot (165 - T_{op})/80$	
Operating voltage V_{op} for short operating periods (V_{DC} or V_{AC} at $f \leq 1$ KHz)	T_{op} (°C)	DC voltage (max. hours)	
	$T_{op} \leq 85$ $85 < T_{op} \leq 110$	$V_{op} = 1.25 \cdot V_R$ (1000h) $V_{op} = 1.25 \cdot V_C$ (1000h)	
Insulation resistance R_{ins} at 500 VDC, rel. humidity ≤ 65%	> 100 GΩ		
Test voltage (Terminal to terminal), duration	$1.6 \cdot V_R$, 2 s		
Test voltage (Terminal to case)	2000Vac, 60s		
Maximum Pulse Handling Capability (V/μs)	6200 V / (μs)		
Damp Heat Steady State passing Criteria	1000hrs/60°C /95% relative humidity $V_{R,DC}$ $\left \frac{\Delta C}{C_0} \right \leq 5 \%$, $\tan \delta \leq 1.5 \cdot$ upper limit values(100kHz), $R_{ins} \geq 50 \%$ of initial limit		
Reliability: Failure rate λ Service life t_{SL} For conversion to other operating conditions and temperatures, refer to chapter "Reliability"	1 fit ($\leq 1 \cdot 10^{-9}$) @ $0.5 \cdot V_R$, 40°C 200 000 h @ $1.0 \cdot V_R$, 85 °C		

Cautions and warnings

- Do not exceed the upper category temperature (UCT).
- Do not apply any mechanical stress to the capacitor terminals.
- Avoid any compressive, tensile or flexural stress.
- Do not move the capacitor after it has been soldered to the PC board.
- Do not pick up the PC board by the soldered capacitor.
- Do not place the capacitor on a PC board whose PTH hole spacing differs from the specified lead spacing.
- Do not exceed the specified time or temperature limits during soldering.
- Avoid external energy inputs, such as fire or electricity.
- Avoid overload of the capacitors.

The table below summarizes the safety instructions that must always be observed. A detailed description can be found in the relevant sections of the chapters "General technical information" and "Mounting guidelines".

Topic	Safety information	Reference chapter "General technical information"
Storage conditions	Make sure that capacitors are stored within the specified range of time, temperature and humidity conditions.	4.5 "Storage conditions"
Flammability	Avoid external energy, such as fire or electricity (passive flammability), avoid overload of the capacitors (active flammability) and consider the flammability of materials.	5.3 "Flammability"
Resistance to vibration	Do not exceed the tested ability to withstand vibration. The capacitors are tested to IEC 60068-2-6. EPCOS offers film capacitors specially designed for operation under more severe vibration regimes such as those found in automotive applications. Consult our catalog "Film Capacitors for Automotive Electronics".	5.2 "Resistance to vibration"
Topic	Safety information	Reference chapter "Mounting guidelines"
Soldering	Do not exceed the specified time or temperature limits during soldering.	1 "Soldering"
Cleaning	Use only suitable solvents for cleaning capacitors.	2 "Cleaning"
Embedding of capacitors in finished assemblies	When embedding finished circuit assemblies in plastic resins, chemical and thermal influences must be taken into account. Caution: Consult us first, if you also wish to embed other uncoated component types!	3 "Embedding of capacitors in finished assemblies"

Display of ordering codes for EPCOS products

The ordering code for one and the same EPCOS product can be represented differently in data sheets, data books, other publications, on the EPCOS website, or in order-related documents such as shipping notes, order confirmations and product labels. **The varying representations of the ordering codes are due to different processes employed and do not affect the specifications of the respective products.** Detailed information can be found on the Internet under www.epcos.com/orderingcodes

Important notes

The following applies to all products named in this publication:

1. Some parts of this publication contain **statements about the suitability of our products for certain areas of application**. These statements are based on our knowledge of typical requirements that are often placed on our products in the areas of application concerned. We nevertheless expressly point out **that such statements cannot be regarded as binding statements about the suitability of our products for a particular customer application**. As a rule, EPCOS is either unfamiliar with individual customer applications or less familiar with them than the customers themselves. For these reasons, it is always ultimately incumbent on the customer to check and decide whether an EPCOS product with the properties described in the product specification is suitable for use in a particular customer application.
2. We also point out that **in individual cases, a malfunction of electronic components or failure before the end of their usual service life cannot be completely ruled out in the current state of the art, even if they are operated as specified**. In customer applications requiring a very high level of operational safety and especially in customer applications in which the malfunction or failure of an electronic component could endanger human life or health (e.g. in accident prevention or life-saving systems), it must therefore be ensured by means of suitable design of the customer application or other action taken by the customer (e.g. installation of protective circuitry or redundancy) that no injury or damage is sustained by third parties in the event of malfunction or failure of an electronic component.
3. **The warnings, cautions and product-specific notes must be observed.**
4. In order to satisfy certain technical requirements, **some of the products described in this publication may contain substances subject to restrictions in certain jurisdictions (e.g. because they are classed as hazardous)**. Useful information on this will be found in our Material Data Sheets on the Internet (www.epcos.com/material). Should you have any more detailed questions, please contact our sales offices.
5. We constantly strive to improve our products. Consequently, **the products described in this publication may change from time to time**. The same is true of the corresponding product specifications. Please check therefore to what extent product descriptions and specifications contained in this publication are still applicable before or when you place an order. We also **reserve the right to discontinue production and delivery of products**. Consequently, we cannot guarantee that all products named in this publication will always be available. The aforementioned does not apply in the case of individual agreements deviating from the foregoing for customer-specific products.
6. Unless otherwise agreed in individual contracts, **all orders are subject to the current version of the "General Terms of Delivery for Products and Services in the Electrical Industry" published by the German Electrical and Electronics Industry Association (ZVEI)**.
7. **Our manufacturing sites serving the automotive business apply the IATF 16949 standard**. The IATF certifications confirm our compliance with requirements regarding the quality management system in the automotive industry. Referring to customer requirements and customer specific requirements ("CSR") TDK always has and will continue to have the policy of respecting individual agreements. Even if IATF 16949 may appear to support the acceptance of unilateral requirements, we hereby like to emphasize that **only requirements mutually agreed upon can and will be implemented in our Quality Management System**. For clarification purposes we like to point out that obligations from IATF 16949 shall only become legally binding if individually agreed upon.

Important notes

8. The trade names EPCOS, CeraCharge, CeraDiode, CeraLink, CeraPad, CeraPlas, CSMP, CTVS, DeltaCap, DigiSiMic, ExoCore, FilterCap, FormFit, LeaXield, MiniBlue, MiniCell, MKD, MKK, MotorCap, PCC, PhaseCap, PhaseCube, PhaseMod, PhiCap, PowerHap, PQSine, PQvar, SIFERRIT, SIFI, SIKOREL, SilverCap, SIMDAD, SiMic, SIMID, SineFormer, SIOV, ThermoFuse, WindCap are **trademarks registered or pending** in Europe and in other countries. Further information will be found on the Internet at www.epcos.com/trademarks.

Release 2018-06