

Description

RSFD1702C is a high performance duplexer designed for applications in LTE Band 3 (1710 – 1785 MHz UL, 1805 – 1880 MHz DL).

RSFD1702C is designed with Film Bulk Acoustic Resonator (FBAR) technology, which provides high-Q filters and meet requirements of low insertion loss, high out-of-band attenuation, high power handling and stringent linearity.

RSFD1702C uses chip scale packaging (CSP) technology to assembly the filters into a molded chip-on-board module with the footprint of 1.8mm x 1.4mm and height of 0.61mm.

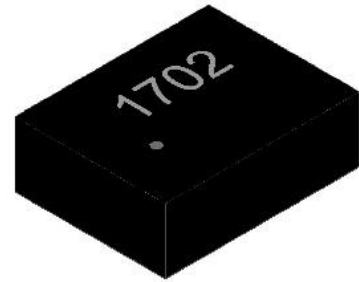

Features

- Miniature Size
1.8 mm x 1.4 mm x 0.61 mm
- Low insertion loss
 - TX band, 1710-1785MHz: 1.5dB Typ.
 - RX band, 1805-1880MHz: 1.8dB Typ.
- High Isolation
 - TX isolation: 60dB Typ.
 - RX isolation: 58dB Typ.
- Input power
 - +29 dBm CW for 5000h @ +55 deg.C
- Single-ended(SE) 50ohm receive & transmit ports
- Storage Temperature: -40 to +85 deg.C

Environmental

- Full implement with RoHS compliant
- Lead Free (Pb free)



Functional Block Diagram (Top Thru View)

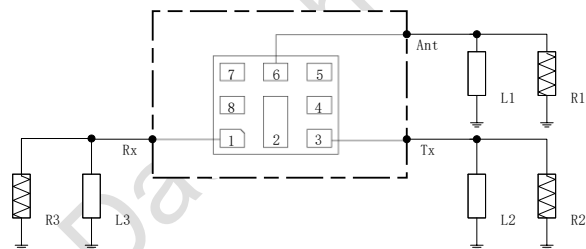

Reference Des.	Value	Description	Manuf.
R1	50ohm		
R2	50ohm		
R3	50ohm		
L1	3nH	Ideal inductor	
L2	7.5nH	Ideal inductor	
L3	5.1nH	Ideal inductor	

Pin Connection

No.	Function
1	Rx
3	Tx
6	Ant
2,4,5,7,8	Ground

Electrical Specification

Transmit Port to Antenna Port				
Parameter(Operable Temperature: -20 to +85 deg.C)	Min	Typ*	Max	Unit
Insertion Loss (1710~1785MHz)	\	1.5	2.5	dB
Ripple (1710~1785MHz)	\	0.4	1 ⁽¹⁾	dB
VSWR (1710~1785MHz,ANT)	\	1.3	1.5	\
VSWR (1710~1785MHz,TX)	\	1.3	1.5	\
Absolute Attenuation				
(10~1565.4MHz)	30	45	\	dB
Wideband GPS (1565.4~1573.4MHz)	40	43	\	dB
Regular GPS (1573.4~1577.5MHz)	40	43	\	dB
Wideband GPS (1577.5~1585.4MHz)	40	44	\	dB
GLONASS (1597.6~1605.9MHz)	42	48	\	dB
(1605.9~1680MHz)	8	40	\	dB
RX Band (1805~1880MHz)	43	53	\	dB
Band1 RX (2110~2170MHz)	36	40	\	dB
ISM Band (2400~2500MHz)	42	46	\	dB
Band7 RX (2620~2690MHz)	36	40	\	dB
(3420~3570MHz, 2f0)	30	34	\	dB
(5130~5355MHz, 3f0)	15	17	\	dB
Antenna Port to Receive Port				
Parameter(Operable Temperature: -20 to +85 deg.C)	Min	Typ*	Max	Unit
Insertion Loss (1805~1880MHz)	\	1.8	3.5	dB
Ripple (1805~1880MHz)	\	0.5	1 ⁽¹⁾	dB
VSWR (1805~1880MHz,ANT)	\	1.6	1.9	\
VSWR (1805~1880MHz,RX)	\	1.6	1.9	\
Absolute Attenuation				
(10~1710MHz)	25	50	\	dB
TX Band (1710~1785MHz)	43	60	\	dB
(1920~6000MHz)	30	45	\	dB
ISM Band (2400~2500MHz)	44	50	\	dB
Band7 TX (2500~2570MHz)	47	51	\	dB
(2570~3515MHz)	50	55	\	dB
(3515~3760MHz, 2f0)	50	53	\	dB
ISM 5G (4900~5950MHz)	31	39	\	dB
(5205~5660MHz, 3f0)	32	36	\	dB

Parameter(Operable Temperature: -20 to +85 deg.C)	Min	Typ*	Max	Unit
Transmit Port to Receive Port				
Isolation				
1710~1785MHz	50	60	\	dB
1805~1880MHz	50	58	\	dB

*Data is the integrated value of the linear s-parameter over indicated band.

(1) Data is the integrated Max value of the linear S-parameter over 5MHz.

ROFS Preliminary Data Sheet

Typical Performance at Tc=25 deg.C

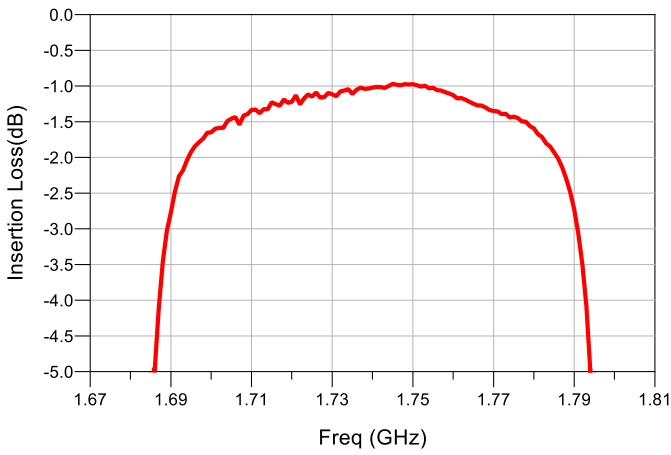

Figure1. TX-ANT Passband

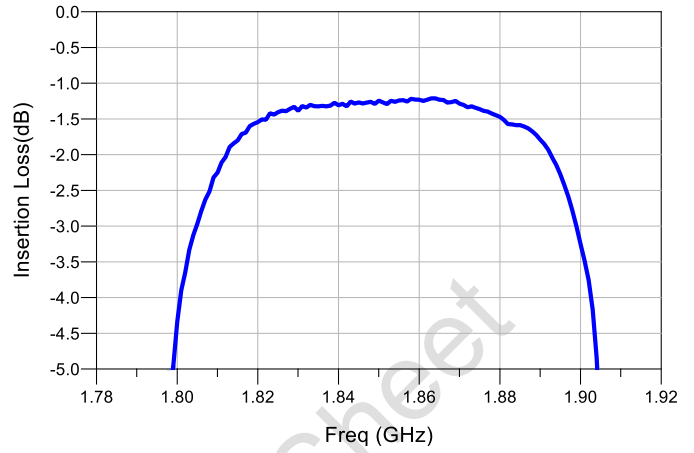

Figure2. ANT-RX Passband

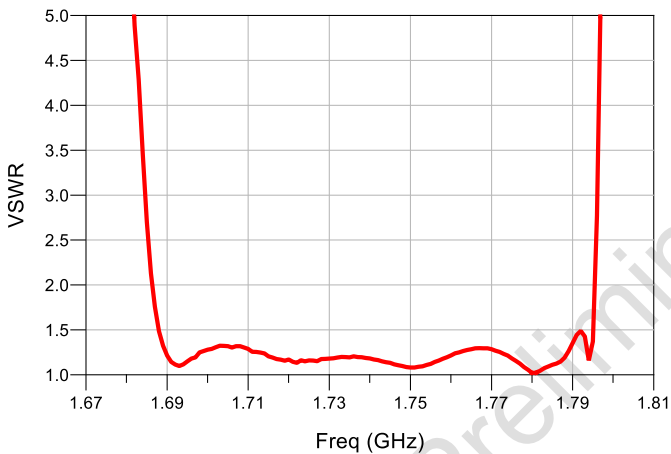

Figure3. TX Port VSWR

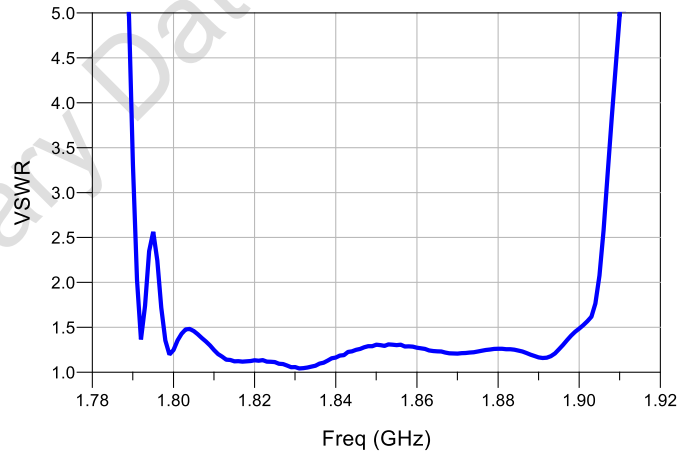

Figure4. RX Port VSWR

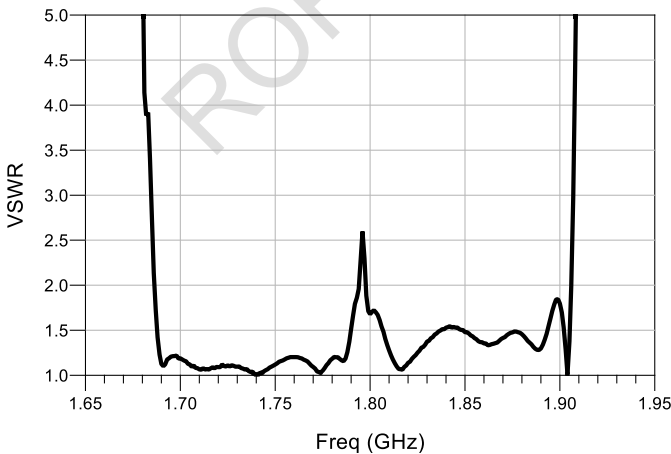

Figure5. ANT Port VSWR

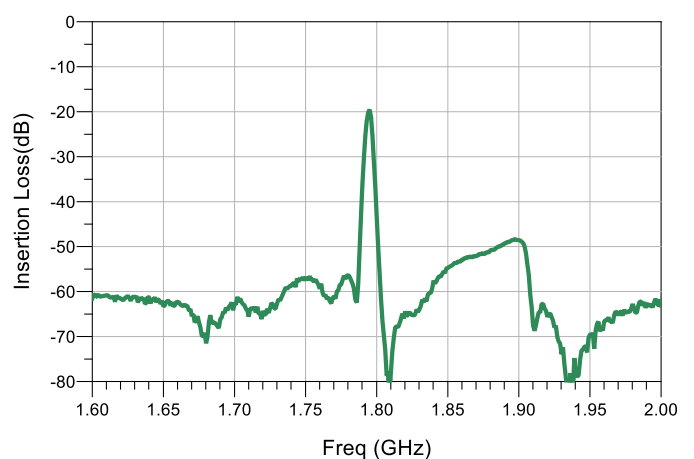

Figure6. TX RX Isolation

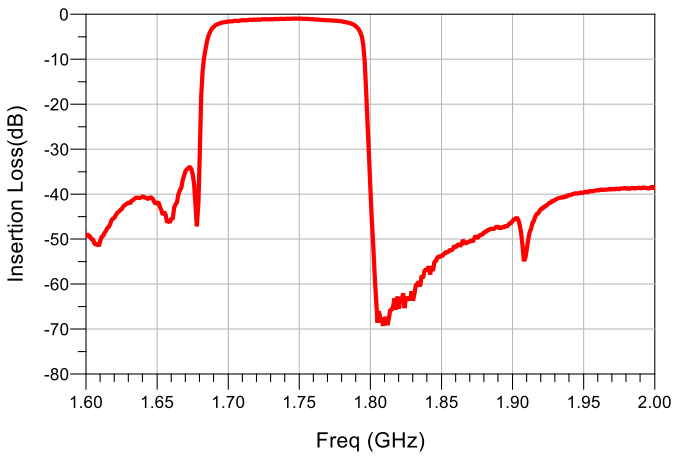

Figure7. TX-ANT

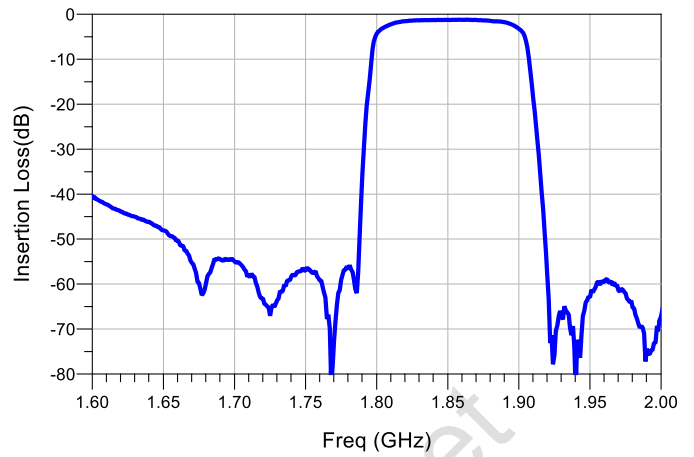

Figure8. ANT-RX

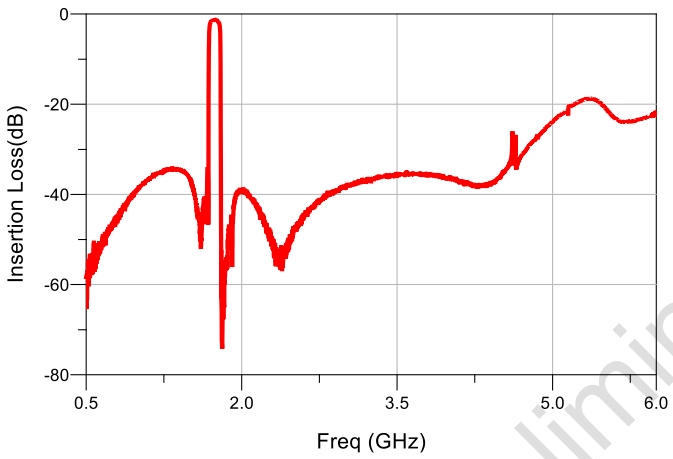

Figure9. TX-ANT Wideband

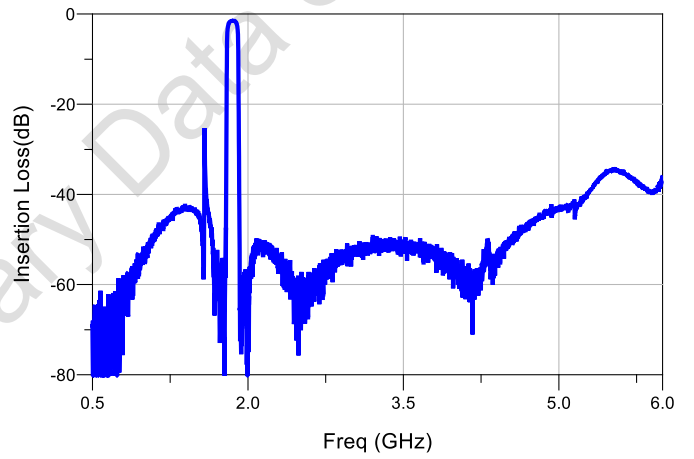

Figure10. ANT-RX Wideband

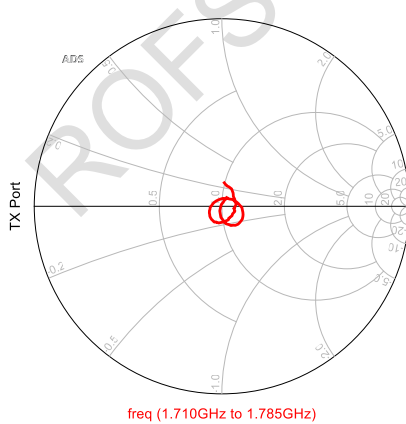

Figure11. TX Port (TX Passband) Smith Chart

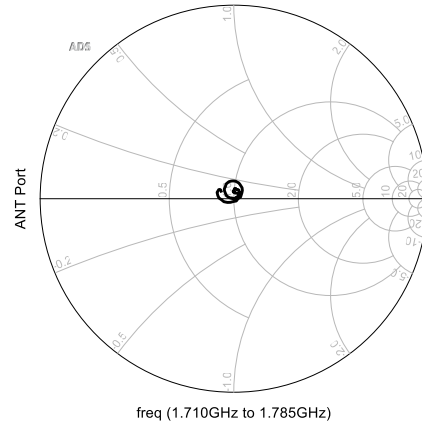

Figure12. ANT Port (TX Passband) Smith Chart

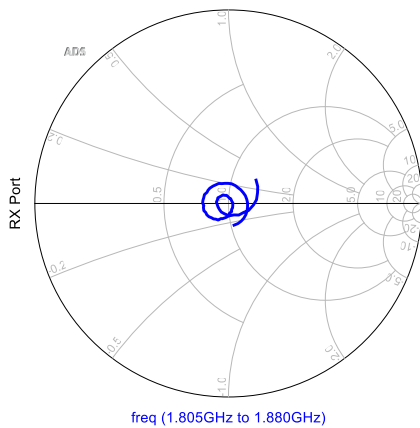

Figure13. RX Port (RX Passband) Smith Chart

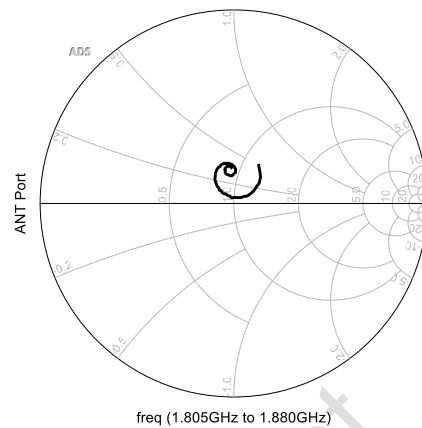
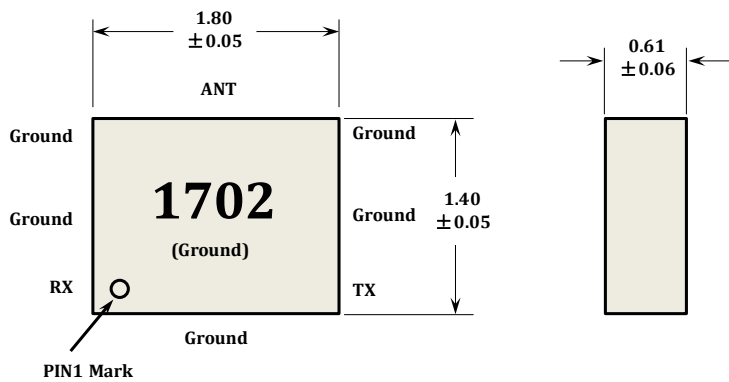

Figure14. ANT Port (RX Passband) Smith Chart

Package Outline



Top view

Side view

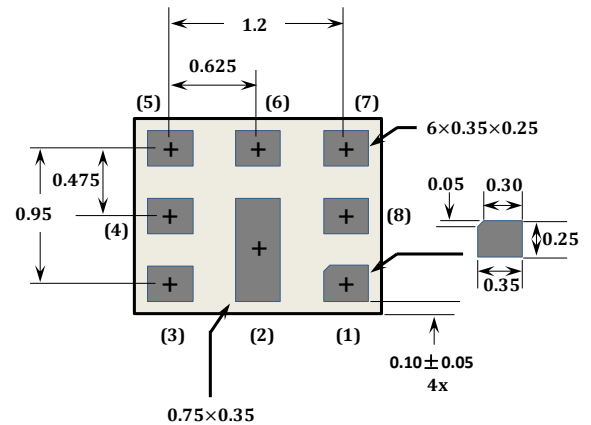

Bottom view

Note:

1. Dimension: mm
2. Dimensions nominal unless otherwise noted
3. Contact area are gold plated
4. Pad(1) (2) is single size, others are same size
5. 1702 is product code

No.	Function
1	Rx
3	Tx
6	Ant
2,4,5,7,8	Ground

Order Information

P/N	Qty/Reel	Container
RSFD1702C	4000	7 inch Reel

Packing

1. Tape Dimension

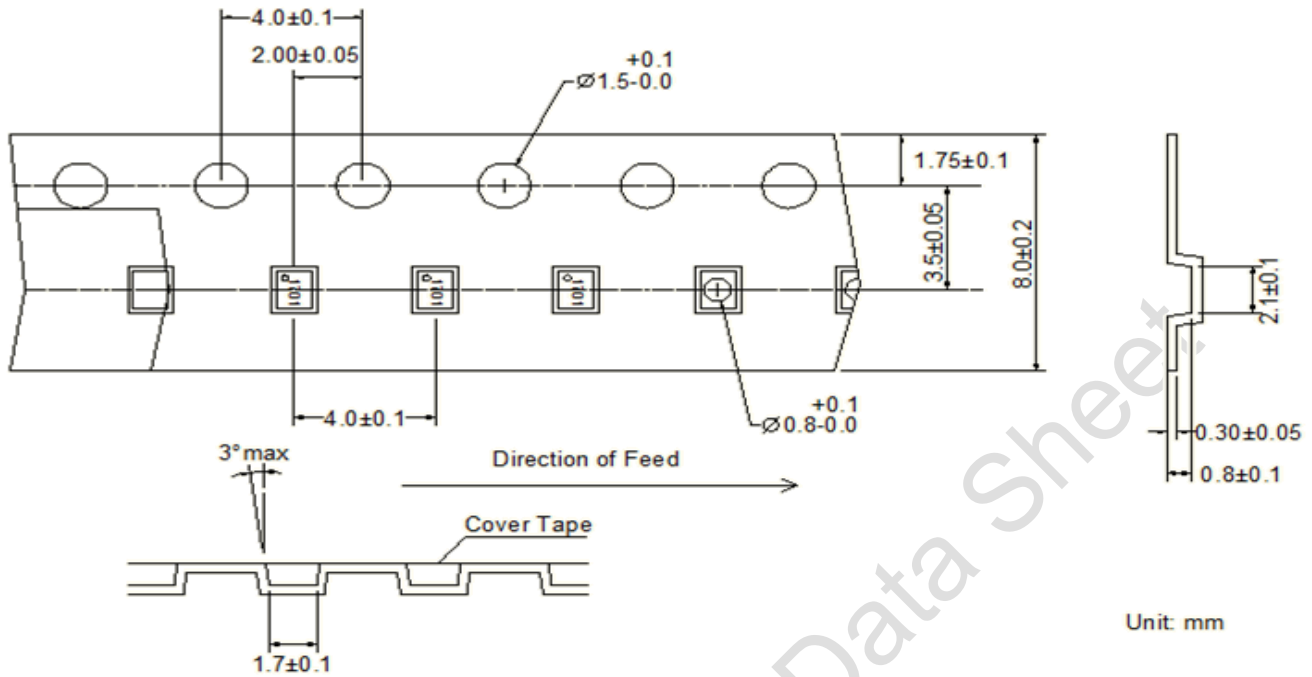

2. Reel Dimension

4000Pcs/Reel

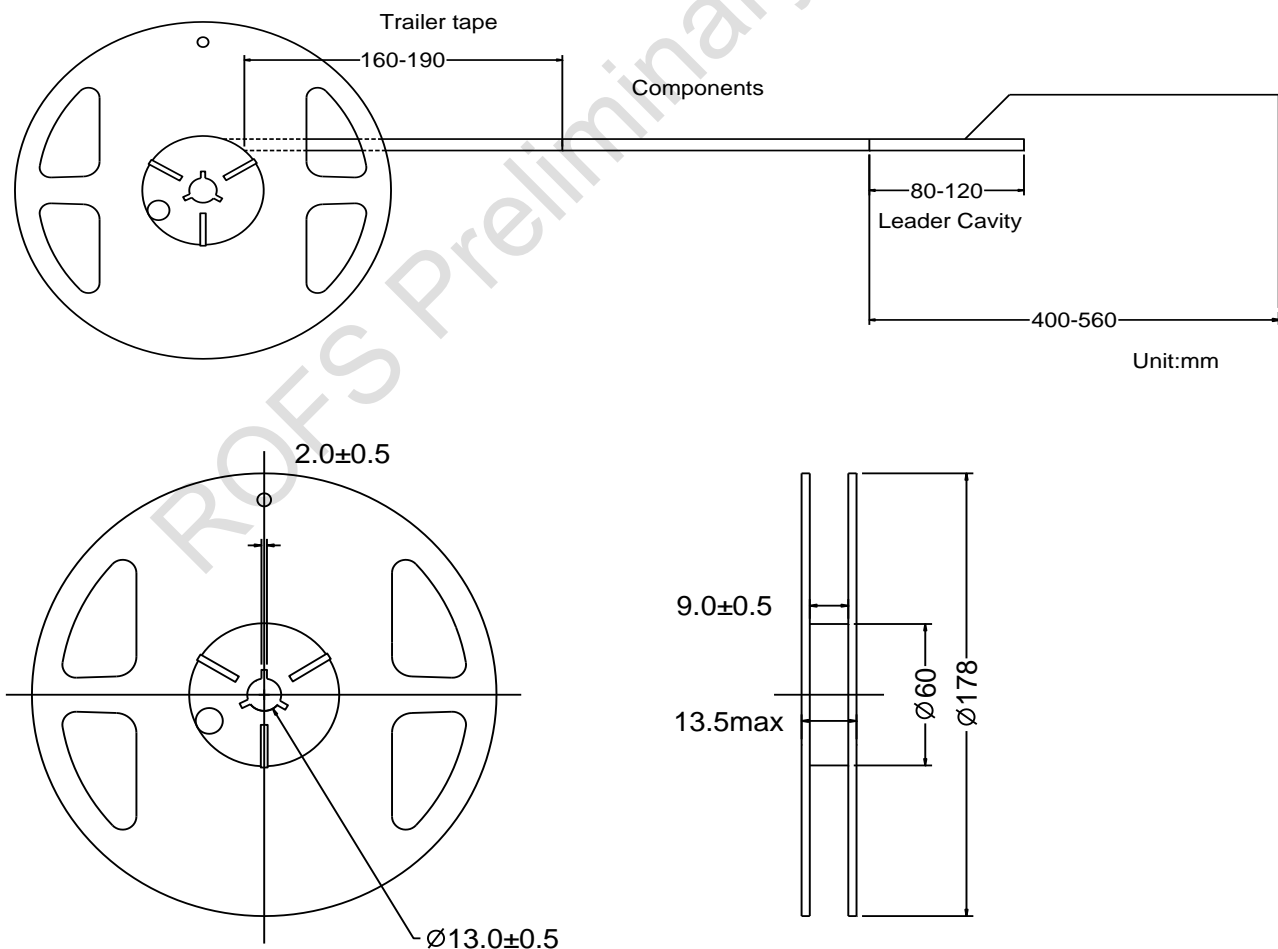

Recommended Reflow Profile

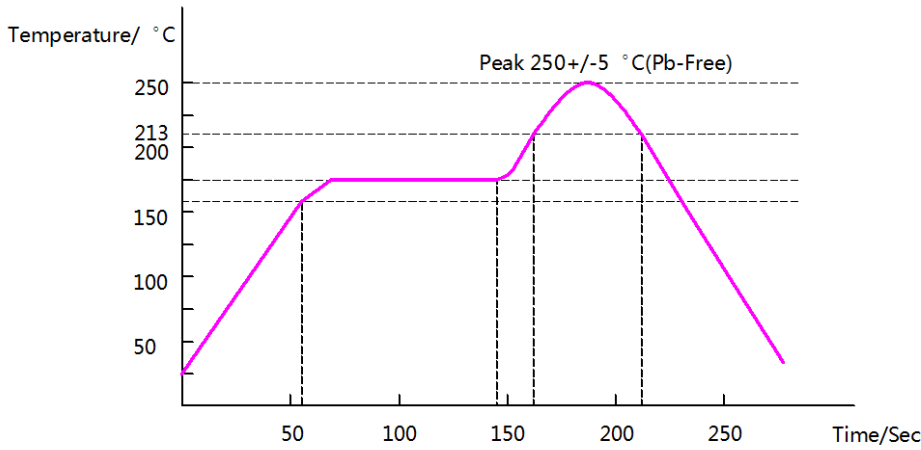

For more information, please contact: sales@rofsmicro.com

Notes:

The specification may be changed or the product had been discontinued, please check with our sales or product engineer before order.