

Messrs. ALMAR

# ALUMINUM ELECTROLYTIC CAPACITORS SPECIFICATION SHEET

RoHS compliance

CUSTOMER PART No.		
Rubycon PART No.	MXK SERIES (PET Sleeve)	
DRAWING No.	REE - 046517	ISSUE No. 5
ISSUE DATE	27 December 2017	



**RUBYCON CORPORATION**  
ENGINEERING DIVISION  
ELECTROLYTIC CAPACITOR DESIGN DEPT.

1938-1, NISHIMINOWA, INA-SHI, NAGANO-KEN, JAPAN  
TEL No. +81-265-72-7116  
FAX No. +81-265-73-3380

DESIGN	KAZUYA IGUCHI
	<i>K. Iguchi</i>
CHECK	HIROKAZU HORIKAWA
	<i>H. Horikawa</i>
APPROVAL	YUZO SHIBA
	<i>Y. Shiba</i>

REVISIONS					
ISSUE No.	REVISION MARK	DATE	DESCRIPTION	CHECK	APPROVAL
2	△ 1	18 Jan. 2016	<ul style="list-style-type: none"> <li>•Changed Nominal Capacitance.</li> <li>•Changed Frequency Coefficient.</li> <li>•Changed Load Life Test.</li> <li>•Changed Table-2.</li> <li>Added new size</li> </ul>	H.H.	Y.S.
3	△ 2	28 Apr. 2016	<ul style="list-style-type: none"> <li>•Added Packaging method.</li> </ul>	H.H.	Y.S.
4	△ 3	17 Oct. 2016	<ul style="list-style-type: none"> <li>•Changed Table-2.</li> <li>Added new size</li> </ul>	H.H.	Y.S.
5	△ 4	27 Dec. 2017	<ul style="list-style-type: none"> <li>•Added new items 475V and 500V.</li> </ul>	H.H.	Y.S.
MXK SERIES			<b><i>Rubycon</i></b> RUBYCON CORPORATION	1st. ISSUE	5 Nov. 2014
				DRAWING No.	REE – 046517

1.Scope

This specification shall apply to MXK series, polarized aluminum electrolytic capacitors with non-solid electrolyte, which we deliver to you for use in electronic equipment.

2.Conformance Standard

JIS C 5141(1991) and JIS C 5102(1986) methods for testing.

3.Operating Temperature Range

-25 ~ +105°C

4.Performance

Reference to Table -1

5.Style and Numbering System

5-1 Style

CE 692

5-2 Numbering System

Rated Voltage

MXK

Series

Nominal Capacitance

Tolerance

EFC

Option

SN

Terminal Code SN:(Tin Plating)

D X L

Case Size

6.Marking

Unless otherwise specified, capacitor shall be clearly marked on its body.

- (1) Brand
- (2) Mark Indicating Electrolytic Capacitor
- (3) Maximum Operating Temperature
- (4) Rated Voltage
- (5) Nominal Capacitance (Tolerance)
- (6) Series (Sleeve material)
- (7) Polarity
- (8) Lot No.

<Example>

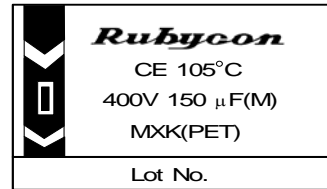

7.Indication of Lot No.

Manufactured year (the last one digit of A.D)

Manufactured month

Twice of Manufactured day



<Example>

Jan.1.2018→8102

(Manufactured month : October = O, November = N, December = D)

8. Packaging method

Conductive film (polyethylene with conductive material) is laid against recovery voltage in the packing.

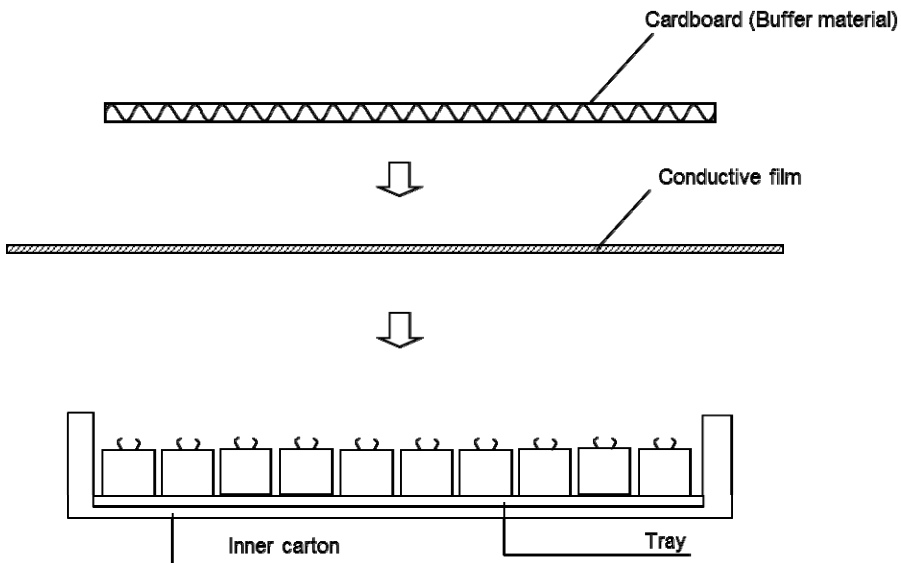

MXK SERIES	<b>Rubycon</b> RUBYCON CORPORATION	DRAWING No.	ISSUE No.
		REE - 046517	5

9. Notes (on the use of aluminum electrolytic capacitors)

(1) Charge and discharge

\*Do not use for a circuit where rapid charge and discharge is frequently repeated.

(2) Insulation

\*Aluminum electrolytic capacitors are covered with P.E.T. sleeve which purpose is mainly indication of necessary items.

\*The case of capacitor and the cathode terminal are not insulated.

(3) Polarity



\*This capacitor has polarity.

\*Please confirm the polarity before use.

\*Guide to application except the above are described in our catalog and EIAJ RCR-2367C

"Safety Application Guide for fixed aluminum electrolytic capacitors for use in electronic equipment."

◆Table – 1 PERFORMANCE

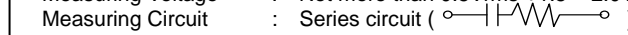
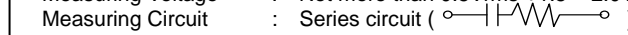
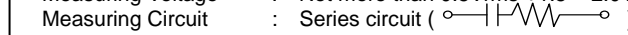
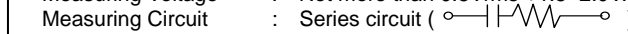
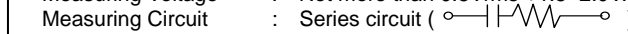
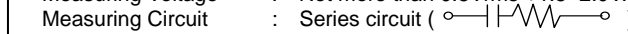
ITEMS		PERFORMANCE																												
1	Rated Voltage	400 ~ 500 V.DC 																												
2	Leakage Current	<p>&lt;Condition&gt;                      D.C. voltage applied to capacitors to measure leakage current shall be controlled so that the voltage reaches the rated voltage within one minute.                      Leakage current shall be measured for 5 minutes after the D.C.voltage applied has Reached the rated voltage across a 1000 ±10 ohm series protection resistor.(20±2°C )</p> <p>&lt;Criteria&gt;  <math>I=3\sqrt{CV}</math> Max.                      I: Leakage Current (μA)                      C: Nominal Capacitance (μF)                      V: Rated Voltage (V.DC)</p>																												
3	Nominal Capacitance (Capacitance Tolerance)	<p>&lt;Criteria&gt;                      68 ~ 1200μF(±20%) </p> <p>&lt;Condition&gt;</p> <table border="1" style="width: 100%;"> <tr> <td>Measuring Frequency</td> <td>: 120Hz ±20%</td> </tr> <tr> <td>Measuring Voltage</td> <td>: Not more than 0.5Vrms +1.5 ~ 2.0V.DC</td> </tr> <tr> <td>Measuring Circuit</td> <td>: Series circuit (  )</td> </tr> <tr> <td>Measuring Temperature</td> <td>: 20±2°C</td> </tr> </table>	Measuring Frequency	: 120Hz ±20%	Measuring Voltage	: Not more than 0.5Vrms +1.5 ~ 2.0V.DC	Measuring Circuit	: Series circuit (  )	Measuring Temperature	: 20±2°C																				
Measuring Frequency	: 120Hz ±20%																													
Measuring Voltage	: Not more than 0.5Vrms +1.5 ~ 2.0V.DC																													
Measuring Circuit	: Series circuit (  )																													
Measuring Temperature	: 20±2°C																													
4	Dissipation Factor (tanδ)	<p>&lt;Criteria&gt;                      Not more than the value of Table - 2</p> <p>&lt;Condition&gt;</p> <table border="1" style="width: 100%;"> <tr> <td>Measuring Frequency</td> <td>: 120Hz ±20%</td> </tr> <tr> <td>Measuring Voltage</td> <td>: Not more than 0.5Vrms +1.5~2.0V.DC</td> </tr> <tr> <td>Measuring Circuit</td> <td>: Series circuit (  )</td> </tr> <tr> <td>Measuring Temperature</td> <td>: 20±2°C</td> </tr> </table>	Measuring Frequency	: 120Hz ±20%	Measuring Voltage	: Not more than 0.5Vrms +1.5~2.0V.DC	Measuring Circuit	: Series circuit (  )	Measuring Temperature	: 20±2°C																				
Measuring Frequency	: 120Hz ±20%																													
Measuring Voltage	: Not more than 0.5Vrms +1.5~2.0V.DC																													
Measuring Circuit	: Series circuit (  )																													
Measuring Temperature	: 20±2°C																													
5	Variation of Characteristics by Temperature	<p>&lt;Condition&gt; Refer to JIS C 5102,7.12</p> <table border="1" style="width: 100%;"> <thead> <tr> <th>STEP</th> <th>Testing Temperature (°C)</th> <th>Time</th> </tr> </thead> <tbody> <tr> <td>1</td> <td>20±2</td> <td>Time to reach thermal equilibrium</td> </tr> <tr> <td>2</td> <td>Minimum operating temperature ±3</td> <td>"</td> </tr> <tr> <td>3</td> <td>20±2</td> <td>"</td> </tr> <tr> <td>4</td> <td>Maximum operating temperature ±2</td> <td>"</td> </tr> <tr> <td>5</td> <td>20±2</td> <td>"</td> </tr> </tbody> </table> <p>&lt;Criteria&gt;</p> <table border="1" style="width: 100%;"> <tbody> <tr> <td>STEP 2</td> <td>Impedance Ratio</td> <td>The value of ratio to STEP 1 not more than value of Impedance ratio</td> </tr> <tr> <td rowspan="3">STEP 4</td> <td>Capacitance Change</td> <td>Within ± 20% of the value of STEP 1</td> </tr> <tr> <td>Dissipation Factor</td> <td>Not more than the value of Table-2</td> </tr> <tr> <td>Leakage Current</td> <td>Not more than 8 times the value of Table-2</td> </tr> </tbody> </table>	STEP	Testing Temperature (°C)	Time	1	20±2	Time to reach thermal equilibrium	2	Minimum operating temperature ±3	"	3	20±2	"	4	Maximum operating temperature ±2	"	5	20±2	"	STEP 2	Impedance Ratio	The value of ratio to STEP 1 not more than value of Impedance ratio	STEP 4	Capacitance Change	Within ± 20% of the value of STEP 1	Dissipation Factor	Not more than the value of Table-2	Leakage Current	Not more than 8 times the value of Table-2
STEP	Testing Temperature (°C)	Time																												
1	20±2	Time to reach thermal equilibrium																												
2	Minimum operating temperature ±3	"																												
3	20±2	"																												
4	Maximum operating temperature ±2	"																												
5	20±2	"																												
STEP 2	Impedance Ratio	The value of ratio to STEP 1 not more than value of Impedance ratio																												
STEP 4	Capacitance Change	Within ± 20% of the value of STEP 1																												
	Dissipation Factor	Not more than the value of Table-2																												
	Leakage Current	Not more than 8 times the value of Table-2																												

ITEMS		PERFORMANCE																						
6	Impedance Ratio	<p>&lt;Condition&gt; Impedance shall be measured at -25°C ,20°C and 120Hz.</p> <p>&lt;Criteria&gt; Impedance Ratio <math>\triangle</math> 4</p> <table border="1"> <tr> <td>Rated Voltage</td> <td>Z(-25°C) / Z(20°C)</td> </tr> <tr> <td>400 ~ 450 V.DC</td> <td>8 MAX</td> </tr> <tr> <td>475 ~ 500 V.DC</td> <td>12 MAX</td> </tr> </table> <p>( Z (-25°C) : Impedance at -25°C Z ( 20°C) : Impedance at 20°C )</p>	Rated Voltage	Z(-25°C) / Z(20°C)	400 ~ 450 V.DC	8 MAX	475 ~ 500 V.DC	12 MAX																
Rated Voltage	Z(-25°C) / Z(20°C)																							
400 ~ 450 V.DC	8 MAX																							
475 ~ 500 V.DC	12 MAX																							
7	Surge Voltage	<p>&lt;Condition&gt; The capacitor shall be applied surge voltage through a (100±50) / CR &lt;kΩ&gt; resistor in series for 30±5 seconds in every 6±0.5 minutes at 15 ~ 35°C. The procedure shall be repeated 1000 times. [CR : Nominal Capacitance (μF )]</p> <p>&lt;Criteria&gt;</p> <table border="1"> <tr> <td>Leakage Current</td> <td>Not more than the value of Table-2</td> </tr> <tr> <td>Capacitance Change</td> <td>Within ±15% of the initial value</td> </tr> <tr> <td>Dissipation Factor</td> <td>Not more than the value of Table-2</td> </tr> <tr> <td>Appearance</td> <td>Notable changes shall not be found</td> </tr> </table> <p>◇This item provides for overvoltage at abnormal situations, and not be hypothesizing that overvoltage is always applied.</p>	Leakage Current	Not more than the value of Table-2	Capacitance Change	Within ±15% of the initial value	Dissipation Factor	Not more than the value of Table-2	Appearance	Notable changes shall not be found														
Leakage Current	Not more than the value of Table-2																							
Capacitance Change	Within ±15% of the initial value																							
Dissipation Factor	Not more than the value of Table-2																							
Appearance	Notable changes shall not be found																							
8	Rated Ripple Current	<p>1)The rated ripple current is the maximum A.C.current at 120Hz which can be applied at 105±2°C. 2)The combined value of the D.C.voltage and the peak A.C.voltage shall not exceed the rated voltage.</p> <p>&lt;Frequency Coefficient&gt;</p> <table border="1"> <tr> <td>Frequency (Hz)</td> <td>60(50)</td> <td>120(100)</td> <td>300</td> <td>500</td> <td>1k</td> <td>10k≤</td> </tr> <tr> <td>Coefficient</td> <td>0.80</td> <td>1.00</td> <td>1.15</td> <td>1.20</td> <td>1.25</td> <td>1.40</td> </tr> </table> <p>&lt;Temperature Coefficient&gt;</p> <table border="1"> <tr> <td>Ambient Temperature (°C)</td> <td>105</td> <td>85</td> <td>65≥</td> </tr> <tr> <td>Coefficient</td> <td>1.0</td> <td>1.88</td> <td>2.26</td> </tr> </table> <p>◇Temperature coefficient shows a limit of ripple current exceeding the rated ripple current that can be passed through a capacitor at each temperature when the life expectancy of a capacitor becomes to be nearly equal with the lifetime at the rated maximum operating temperature.</p>	Frequency (Hz)	60(50)	120(100)	300	500	1k	10k≤	Coefficient	0.80	1.00	1.15	1.20	1.25	1.40	Ambient Temperature (°C)	105	85	65≥	Coefficient	1.0	1.88	2.26
Frequency (Hz)	60(50)	120(100)	300	500	1k	10k≤																		
Coefficient	0.80	1.00	1.15	1.20	1.25	1.40																		
Ambient Temperature (°C)	105	85	65≥																					
Coefficient	1.0	1.88	2.26																					
9	Resistance to Soldering Heat	<p>&lt;Condition&gt; Refer to JIS C 5102,8.5 The terminal shall be immersed into solder bath at 260±5°C for 10±1 seconds up to 1.5-2.0mm from the body of capacitor. After the test, the capacitor shall meet the following requirements.</p> <p>&lt;Criteria&gt;</p> <table border="1"> <tr> <td>Leakage Current</td> <td>Not more than the value of Table - 2</td> </tr> <tr> <td>Capacitance Change</td> <td>Within ±10%of the initial value</td> </tr> <tr> <td>Dissipation Factor</td> <td>Not more than the value of Table - 2</td> </tr> <tr> <td>Appearance</td> <td>Notable changes shall not be found</td> </tr> </table>	Leakage Current	Not more than the value of Table - 2	Capacitance Change	Within ±10%of the initial value	Dissipation Factor	Not more than the value of Table - 2	Appearance	Notable changes shall not be found														
Leakage Current	Not more than the value of Table - 2																							
Capacitance Change	Within ±10%of the initial value																							
Dissipation Factor	Not more than the value of Table - 2																							
Appearance	Notable changes shall not be found																							
10	Resistance to Damp Heat (Steady State)	<p>&lt;Condition&gt; Refer to JIS C 5102,9.5 The capacitor shall be stored in the ambient of 40±2°C and relative humidity 90~95% for 240±8 hours. After the test, the capacitor shall meet the following requirements.</p> <p>&lt;Criteria&gt;</p> <table border="1"> <tr> <td>Leakage Current</td> <td>Not more than the value of Table - 2</td> </tr> <tr> <td>Capacitance Change</td> <td>Within ±10%of the initial value</td> </tr> <tr> <td>Dissipation Factor</td> <td>Not more than the value of Table - 2</td> </tr> <tr> <td>Appearance</td> <td>Notable changes shall not be found</td> </tr> </table>	Leakage Current	Not more than the value of Table - 2	Capacitance Change	Within ±10%of the initial value	Dissipation Factor	Not more than the value of Table - 2	Appearance	Notable changes shall not be found														
Leakage Current	Not more than the value of Table - 2																							
Capacitance Change	Within ±10%of the initial value																							
Dissipation Factor	Not more than the value of Table - 2																							
Appearance	Notable changes shall not be found																							

ITEMS		PERFORMANCE								
11	Load Life Test	<p>&lt;Condition&gt;                      D.C.voltage and maximum rated ripple current shall be applied to capacitors for a period of 3000 +72/0 hours at 105±2°C.                      The D.C.voltage and peak A.C.voltage combined must not exceed the rated voltage.                      The capacitors under test shall be protected against direct heat radiation from the heat source.                      After the test, the capacitor shall meet the following requirements.</p> <p>&lt;Criteria&gt;</p> <table border="1"> <tr> <td>Leakage Current</td> <td>Not more than the value of Table - 2</td> </tr> <tr> <td>Capacitance Change</td> <td>Within ±20%of the initial value</td> </tr> <tr> <td>Dissipation Factor</td> <td>Not more than 200% of the value of Table - 2</td> </tr> <tr> <td>Appearance</td> <td>Notable changes shall not be found</td> </tr> </table>	Leakage Current	Not more than the value of Table - 2	Capacitance Change	Within ±20%of the initial value	Dissipation Factor	Not more than 200% of the value of Table - 2	Appearance	Notable changes shall not be found
Leakage Current	Not more than the value of Table - 2									
Capacitance Change	Within ±20%of the initial value									
Dissipation Factor	Not more than 200% of the value of Table - 2									
Appearance	Notable changes shall not be found									
12	Shelf Life Test	<p>&lt;Condition&gt;                      Capacitors shall be stored at 105±2°C for a period of 1000 +48/0 hours with no voltage applied.                      Then the capacitors shall be left under the normal temperature and normal humidity for 16 hours before measurement.                      (If any doubt arises on the judgement, the capacitors shall be subjected to voltage treatment specified in JIS C 5141,5.2.)</p> <p>&lt;Criteria&gt;</p> <table border="1"> <tr> <td>Leakage Current</td> <td>Not more than the value of Table - 2</td> </tr> <tr> <td>Capacitance Change</td> <td>Within ±20%of the initial value</td> </tr> <tr> <td>Dissipation Factor</td> <td>Not more than 200% of the value of Table-2</td> </tr> <tr> <td>Appearance</td> <td>Notable changes shall not be found</td> </tr> </table>	Leakage Current	Not more than the value of Table - 2	Capacitance Change	Within ±20%of the initial value	Dissipation Factor	Not more than 200% of the value of Table-2	Appearance	Notable changes shall not be found
Leakage Current	Not more than the value of Table - 2									
Capacitance Change	Within ±20%of the initial value									
Dissipation Factor	Not more than 200% of the value of Table-2									
Appearance	Notable changes shall not be found									
13	Terminal Strength	<p>&lt;Condition&gt;</p> <p>◆Tensile Strength of Terminals                      The body of capacitors shall be fixed and the tensile force of 20N (2.0 kgf) shall be applied to the terminal in the lead out direction of the terminal for 10±1 seconds.</p> <p>◆Bending Strength of Terminals                      The body of capacitors shall be fixed.                      The weight of 25N(2.5 kgf) shall be applied to the terminal in the perpendicular direction against the lead out direction of the terminal at the part of 1.6mm from the body for 30±5 seconds.                      At this time, if permanent change occurs in the terminal , the weight shall be removed, and the terminal shall be made straight to be the original form.                      Then the weight shall be applied in the opposite direction with the same way.</p> <p>&lt;Criteria&gt;                      Notable changes shall not be found, as breakage or looseness in the terminal.</p>								
14	Solderability	<p>&lt;Condition&gt;                      Terminals of the capacitor shall be immersed in flux (ethanol solution of the rosin , 25 wt% rosin in weight ratio) for 5 ~ 10 seconds and shall be immersed in the solder bath (235±5°C) at a rate of 25±2.5mm per second, and holded for 2±0.5 seconds, and pulled out at the same rate.</p> <p>&lt;Criteria&gt;                      At least 3/4 of circumferential surface of the dipped portion of the terminal shall be covered with new solder.</p>								

ITEMS		PERFORMANCE						
15	Resistance to Vibration	<p>&lt;Condition&gt; Testing shall be done out in 3 AXIS for 2 hours each (total 6 hours) as below. Capacitors shall be fixed by using a mounting clamp.</p> <p style="text-align: center;">( Vibration frequency range : 10 ~ 55 Hz Peak to peak amplitude : 1.5mm Sweep rate : 10 – 55 – 10Hz, about 1 min. )</p> <p>&lt;Criteria&gt;</p> <table border="1"> <tr> <td>Capacitance (During test)</td> <td>Measured value shall be stabilized. (The time from one end to the other of the vibration frequency within last 30 minutes at last direction.)</td> </tr> <tr> <td>Capacitance Change</td> <td>Within ±5% of the initial value</td> </tr> <tr> <td>Appearance</td> <td>Notable changes shall not be found</td> </tr> </table>	Capacitance (During test)	Measured value shall be stabilized. (The time from one end to the other of the vibration frequency within last 30 minutes at last direction.)	Capacitance Change	Within ±5% of the initial value	Appearance	Notable changes shall not be found
Capacitance (During test)	Measured value shall be stabilized. (The time from one end to the other of the vibration frequency within last 30 minutes at last direction.)							
Capacitance Change	Within ±5% of the initial value							
Appearance	Notable changes shall not be found							
16	Solvent Resistance Test (Sleeve Marking)	<p>&lt;Condition&gt; Refer to JIS C 5102,8.7</p> <p style="text-align: center;">( Solvent : Isopropyl alcohol Temperature : 20 ~ 25°C Immersing Time : 30±5 seconds )</p> <p>&lt;Criteria&gt; Notable changes shall not be found, and marking shall be read easily.</p>						
17	Vent Test	<p>&lt;Condition&gt; ◆ D.C. reverse voltage method Capacitor shall be subjected to D.C. current given in the table below at reverse polarity.</p> <table border="1"> <thead> <tr> <th>Norminal body diameter of the capacitor</th> <th>D.C.current (A)</th> </tr> </thead> <tbody> <tr> <td>φ22.4 or less</td> <td>1</td> </tr> <tr> <td>more than φ22.4</td> <td>10</td> </tr> </tbody> </table> <p>The capacitor shall meet the following requirements.</p> <p>Note : When the Pressure relief vent does not open even 30 minutes after beginning of this test, the test may be ended.</p> <p>&lt;Criteria&gt; When the pressure relief vent functions, internal capacitor elements will be contained by the case and no flaming material will be present. No other hazardous conditions shall be observed.</p>	Norminal body diameter of the capacitor	D.C.current (A)	φ22.4 or less	1	more than φ22.4	10
Norminal body diameter of the capacitor	D.C.current (A)							
φ22.4 or less	1							
more than φ22.4	10							

◆DIMENSIONS (unit : mm)

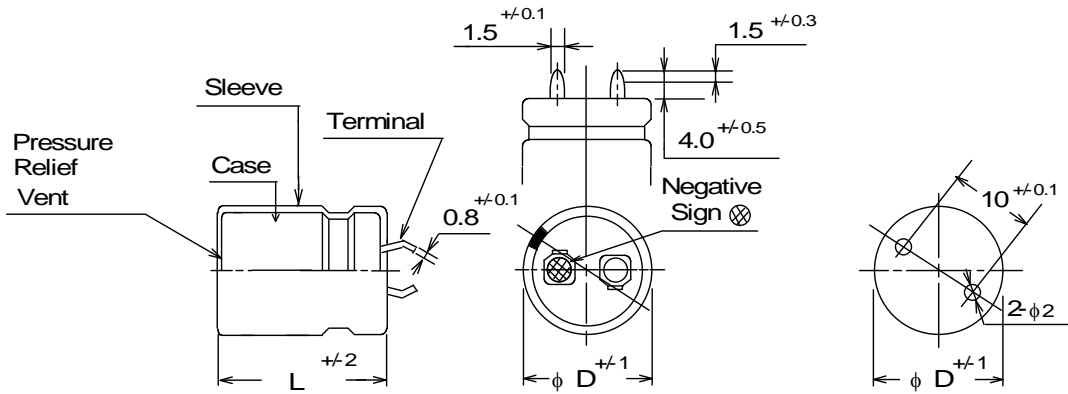

< P.C.BOARD DIMENSIONS >

NAME	MATERIAL	APPEARANCE
SLEEVE	P.E.T.	Black
CASE	Al	
SEAL	Rubber – laminated bakelite	
TERMINAL	SPCC (Tin plating)	



Table - 2 SIZE AND CHARACTERISTICS TABLE

4

Rubycon Part Number		Rated Voltage (V.DC)	Surge Voltage (V.DC)	Nominal Capacitance ( $\mu$ F)	Cap. Tolerance (%)	tan $\delta$ MAX.	MAX. Leakage Current ( $\mu$ A)	Rated Ripple Current (A r.m.s.) 105deg.C /120Hz	Dimension (mm)	
									$\phi$ D	L
400 MXK	150 M EFC SN 22 X 25	400	450	150	$\pm$ 20	0.20	734	1.03	22	25
400 MXK	180 M EFC SN 22 X 30	400	450	180	$\pm$ 20	0.20	804	1.19	22	30
400 MXK	180 M EFC SN 25 X 25	400	450	180	$\pm$ 20	0.20	804	1.15	25	25
400 MXK	220 M EFC SN 22 X 30	400	450	220	$\pm$ 20	0.20	889	1.26	22	30
400 MXK	220 M EFC SN 22 X 35	400	450	220	$\pm$ 20	0.20	889	1.37	22	35
400 MXK	220 M EFC SN 25 X 25	400	450	220	$\pm$ 20	0.20	889	1.20	25	25
400 MXK	220 M EFC SN 25 X 30	400	450	220	$\pm$ 20	0.20	889	1.32	25	30
400 MXK	270 M EFC SN 22 X 35	400	450	270	$\pm$ 20	0.20	985	1.44	22	35
400 MXK	270 M EFC SN 22 X 40	400	450	270	$\pm$ 20	0.20	985	1.56	22	40
400 MXK	270 M EFC SN 25 X 30	400	450	270	$\pm$ 20	0.20	985	1.43	25	30
400 MXK	270 M EFC SN 30 X 25	400	450	270	$\pm$ 20	0.20	985	1.37	30	25
400 MXK	330 M EFC SN 22 X 45	400	450	330	$\pm$ 20	0.20	1089	1.77	22	45
400 MXK	330 M EFC SN 25 X 35	400	450	330	$\pm$ 20	0.20	1089	1.65	25	35
400 MXK	330 M EFC SN 30 X 25	400	450	330	$\pm$ 20	0.20	1089	1.39	30	25
400 MXK	330 M EFC SN 30 X 30	400	450	330	$\pm$ 20	0.20	1089	1.56	30	30
400 MXK	390 M EFC SN 22 X 50	400	450	390	$\pm$ 20	0.20	1184	1.97	22	50
400 MXK	390 M EFC SN 25 X 40	400	450	390	$\pm$ 20	0.20	1184	1.85	25	40
400 MXK	390 M EFC SN 30 X 30	400	450	390	$\pm$ 20	0.20	1184	1.65	30	30
400 MXK	390 M EFC SN 35 X 25	400	450	390	$\pm$ 20	0.20	1184	1.48	35	25
400 MXK	470 M EFC SN 22 X 55	400	450	470	$\pm$ 20	0.20	1300	2.11	22	55
400 MXK	470 M EFC SN 22 X 60	400	450	470	$\pm$ 20	0.20	1300	2.20	22	60
400 MXK	470 M EFC SN 25 X 45	400	450	470	$\pm$ 20	0.20	1300	2.07	25	45
400 MXK	470 M EFC SN 30 X 35	400	450	470	$\pm$ 20	0.20	1300	1.89	30	35
400 MXK	470 M EFC SN 35 X 30	400	450	470	$\pm$ 20	0.20	1300	1.69	35	30
400 MXK	560 M EFC SN 25 X 55	400	450	560	$\pm$ 20	0.20	1419	2.32	25	55
400 MXK	560 M EFC SN 30 X 40	400	450	560	$\pm$ 20	0.20	1419	2.12	30	40
400 MXK	560 M EFC SN 35 X 30	400	450	560	$\pm$ 20	0.20	1419	1.75	35	30
400 MXK	680 M EFC SN 25 X 60	400	450	680	$\pm$ 20	0.20	1564	2.56	25	60
400 MXK	680 M EFC SN 30 X 45	400	450	680	$\pm$ 20	0.20	1564	2.35	30	45
400 MXK	680 M EFC SN 35 X 35	400	450	680	$\pm$ 20	0.20	1564	2.00	35	35
400 MXK	820 M EFC SN 30 X 50	400	450	820	$\pm$ 20	0.20	1718	2.53	30	50
400 MXK	820 M EFC SN 30 X 55	400	450	820	$\pm$ 20	0.20	1718	2.66	30	55
400 MXK	820 M EFC SN 35 X 40	400	450	820	$\pm$ 20	0.20	1718	2.21	35	40
400 MXK	820 M EFC SN 35 X 45	400	450	820	$\pm$ 20	0.20	1718	2.48	35	45
400 MXK	1000 M EFC SN 30 X 60	400	450	1000	$\pm$ 20	0.20	1897	2.91	30	60
400 MXK	1000 M EFC SN 35 X 50	400	450	1000	$\pm$ 20	0.20	1897	2.70	35	50
400 MXK	1200 M EFC SN 35 X 55	400	450	1200	$\pm$ 20	0.20	2078	2.85	35	55
400 MXK	1200 M EFC SN 35 X 60	400	450	1200	$\pm$ 20	0.20	2078	2.99	35	60
420 MXK	120 M EFC SN 22 X 25	420	470	120	$\pm$ 20	0.20	673	0.95	22	25
420 MXK	150 M EFC SN 22 X 25	420	470	150	$\pm$ 20	0.20	752	1.02	22	25
420 MXK	150 M EFC SN 22 X 30	420	470	150	$\pm$ 20	0.20	752	1.10	22	30
420 MXK	180 M EFC SN 22 X 30	420	470	180	$\pm$ 20	0.20	824	1.20	22	30
420 MXK	180 M EFC SN 25 X 25	420	470	180	$\pm$ 20	0.20	824	1.16	25	25
420 MXK	220 M EFC SN 22 X 35	420	470	220	$\pm$ 20	0.20	911	1.38	22	35
420 MXK	220 M EFC SN 25 X 30	420	470	220	$\pm$ 20	0.20	911	1.35	25	30
420 MXK	270 M EFC SN 22 X 40	420	470	270	$\pm$ 20	0.20	1010	1.57	22	40
420 MXK	270 M EFC SN 25 X 35	420	470	270	$\pm$ 20	0.20	1010	1.55	25	35
420 MXK	270 M EFC SN 30 X 25	420	470	270	$\pm$ 20	0.20	1010	1.36	30	25

MXK SERIES

**Rubycon**

RUBYCON CORPORATION

DRAWING No.

REE-046517

ISSUE No.

5

Rubycon Part Number	Rated Voltage (V.DC)	Surge Voltage (V.DC)	Nominal Capacitance ( $\mu$ F)	Cap. Tolerance (%)	tan $\delta$ MAX.	MAX. Leakage Current ( $\mu$ A)	Rated Ripple Current (A r.m.s.) 105deg.C /120Hz	Dimension (mm)	
								$\phi$ D	L
420 MXK 330 M EFC SN 22 X 45	420	470	330	$\pm$ 20	0.20	1116	1.72	22	45
420 MXK 330 M EFC SN 22 X 50	420	470	330	$\pm$ 20	0.20	1116	1.85	22	50
420 MXK 330 M EFC SN 25 X 35	420	470	330	$\pm$ 20	0.20	1116	1.61	25	35
420 MXK 330 M EFC SN 25 X 40	420	470	330	$\pm$ 20	0.20	1116	1.76	25	40
420 MXK 330 M EFC SN 30 X 30	420	470	330	$\pm$ 20	0.20	1116	1.59	30	30
420 MXK 330 M EFC SN 35 X 25	420	470	330	$\pm$ 20	0.20	1116	1.45	35	25
420 MXK 390 M EFC SN 22 X 55	420	470	390	$\pm$ 20	0.20	1214	2.00	22	55
420 MXK 390 M EFC SN 25 X 40	420	470	390	$\pm$ 20	0.20	1214	1.80	25	40
420 MXK 390 M EFC SN 25 X 45	420	470	390	$\pm$ 20	0.20	1214	1.96	25	45
420 MXK 390 M EFC SN 30 X 30	420	470	390	$\pm$ 20	0.20	1214	1.61	30	30
420 MXK 390 M EFC SN 30 X 35	420	470	390	$\pm$ 20	0.20	1214	1.82	30	35
420 MXK 390 M EFC SN 35 X 25	420	470	390	$\pm$ 20	0.20	1214	1.45	35	25
420 MXK 390 M EFC SN 35 X 30	420	470	390	$\pm$ 20	0.20	1214	1.66	35	30
420 MXK 470 M EFC SN 22 X 60	420	470	470	$\pm$ 20	0.20	1332	2.19	22	60
420 MXK 470 M EFC SN 25 X 50	420	470	470	$\pm$ 20	0.20	1332	2.18	25	50
420 MXK 470 M EFC SN 30 X 35	420	470	470	$\pm$ 20	0.20	1332	1.85	30	35
420 MXK 470 M EFC SN 30 X 40	420	470	470	$\pm$ 20	0.20	1332	2.04	30	40
420 MXK 470 M EFC SN 35 X 30	420	470	470	$\pm$ 20	0.20	1332	1.72	35	30
420 MXK 560 M EFC SN 25 X 55	420	470	560	$\pm$ 20	0.20	1454	2.32	25	55
420 MXK 560 M EFC SN 25 X 60	420	470	560	$\pm$ 20	0.20	1454	2.43	25	60
420 MXK 560 M EFC SN 30 X 40	420	470	560	$\pm$ 20	0.20	1454	2.07	30	40
420 MXK 560 M EFC SN 30 X 45	420	470	560	$\pm$ 20	0.20	1454	2.27	30	45
420 MXK 560 M EFC SN 35 X 35	420	470	560	$\pm$ 20	0.20	1454	1.97	35	35
420 MXK 680 M EFC SN 30 X 45	420	470	680	$\pm$ 20	0.20	1603	2.29	30	45
420 MXK 680 M EFC SN 30 X 50	420	470	680	$\pm$ 20	0.20	1603	2.50	30	50
420 MXK 680 M EFC SN 35 X 40	420	470	680	$\pm$ 20	0.20	1603	2.22	35	40
420 MXK 820 M EFC SN 30 X 55	420	470	820	$\pm$ 20	0.20	1760	2.68	30	55
420 MXK 820 M EFC SN 30 X 60	420	470	820	$\pm$ 20	0.20	1760	2.79	30	60
420 MXK 820 M EFC SN 35 X 45	420	470	820	$\pm$ 20	0.20	1760	2.45	35	45
420 MXK 1000 M EFC SN 35 X 50	420	470	1000	$\pm$ 20	0.20	1944	2.64	35	50
420 MXK 1000 M EFC SN 35 X 55	420	470	1000	$\pm$ 20	0.20	1944	2.76	35	55
420 MXK 1200 M EFC SN 35 X 60	420	470	1200	$\pm$ 20	0.20	2129	3.03	35	60
450 MXK 120 M EFC SN 22 X 25	450	500	120	$\pm$ 20	0.20	697	0.95	22	25
450 MXK 150 M EFC SN 22 X 30	450	500	150	$\pm$ 20	0.20	779	1.12	22	30
450 MXK 150 M EFC SN 25 X 25	450	500	150	$\pm$ 20	0.20	779	1.08	25	25
450 MXK 180 M EFC SN 22 X 30	450	500	180	$\pm$ 20	0.20	853	1.17	22	30
450 MXK 180 M EFC SN 22 X 35	450	500	180	$\pm$ 20	0.20	853	1.27	22	35
450 MXK 180 M EFC SN 25 X 25	450	500	180	$\pm$ 20	0.20	853	1.14	25	25
450 MXK 180 M EFC SN 25 X 30	450	500	180	$\pm$ 20	0.20	853	1.24	25	30
450 MXK 220 M EFC SN 22 X 35	450	500	220	$\pm$ 20	0.20	943	1.34	22	35
450 MXK 220 M EFC SN 22 X 40	450	500	220	$\pm$ 20	0.20	943	1.45	22	40
450 MXK 220 M EFC SN 25 X 30	450	500	220	$\pm$ 20	0.20	943	1.34	25	30
450 MXK 220 M EFC SN 30 X 25	450	500	220	$\pm$ 20	0.20	943	1.29	30	25
450 MXK 270 M EFC SN 22 X 40	450	500	270	$\pm$ 20	0.20	1045	1.53	22	40
450 MXK 270 M EFC SN 22 X 45	450	500	270	$\pm$ 20	0.20	1045	1.65	22	45
450 MXK 270 M EFC SN 25 X 35	450	500	270	$\pm$ 20	0.20	1045	1.54	25	35
450 MXK 270 M EFC SN 30 X 25	450	500	270	$\pm$ 20	0.20	1045	1.34	30	25
450 MXK 270 M EFC SN 30 X 30	450	500	270	$\pm$ 20	0.20	1045	1.49	30	30
450 MXK 330 M EFC SN 22 X 50	450	500	330	$\pm$ 20	0.20	1156	1.81	22	50

MXK SERIES

***Rubycon***  
RUBYCON CORPORATION

DRAWING No.

REE-046517

ISSUE No.

5

Rubycon Part Number	Rated Voltage (V.DC)	Surge Voltage (V.DC)	Nominal Capacitance (μF)	Cap. Tolerance (%)	tanδ MAX.	MAX. Leakage Current (μA)	Rated Ripple Current (A r.m.s.) 105deg.C /120Hz	Dimension (mm)		
								φD	L	
450 MXK 330 M EFC SN 22 X 55	450	500	330	±20	0.20	1156	1.88	22	55	
450 MXK 330 M EFC SN 25 X 40	450	500	330	±20	0.20	1156	1.72	25	40	
450 MXK 330 M EFC SN 25 X 45	450	500	330	±20	0.20	1156	1.85	25	45	
450 MXK 330 M EFC SN 30 X 30	450	500	330	±20	0.20	1156	1.58	30	30	
450 MXK 330 M EFC SN 35 X 25	450	500	330	±20	0.20	1156	1.42	35	25	
450 MXK 390 M EFC SN 22 X 55	450	500	390	±20	0.20	1256	1.98	22	55	
450 MXK 390 M EFC SN 22 X 60	450	500	390	±20	0.20	1256	2.07	22	60	
450 MXK 390 M EFC SN 25 X 45	450	500	390	±20	0.20	1256	1.91	25	45	
450 MXK 390 M EFC SN 25 X 50	450	500	390	±20	0.20	1256	2.04	25	50	
450 MXK 390 M EFC SN 30 X 35	450	500	390	±20	0.20	1256	1.80	30	35	
450 MXK 390 M EFC SN 35 X 30	450	500	390	±20	0.20	1256	1.68	35	30	
450 MXK 470 M EFC SN 25 X 55	450	500	470	±20	0.20	1379	2.21	25	55	
450 MXK 470 M EFC SN 30 X 40	450	500	470	±20	0.20	1379	2.02	30	40	
450 MXK 470 M EFC SN 35 X 30	450	500	470	±20	0.20	1379	1.69	35	30	
450 MXK 470 M EFC SN 35 X 35	450	500	470	±20	0.20	1379	1.92	35	35	
450 MXK 560 M EFC SN 25 X 60	450	500	560	±20	0.20	1505	2.41	25	60	
450 MXK 560 M EFC SN 30 X 45	450	500	560	±20	0.20	1505	2.24	30	45	
450 MXK 560 M EFC SN 35 X 35	450	500	560	±20	0.20	1505	1.92	35	35	
450 MXK 560 M EFC SN 35 X 40	450	500	560	±20	0.20	1505	2.15	35	40	
450 MXK 680 M EFC SN 30 X 50	450	500	680	±20	0.20	1659	2.41	30	50	
450 MXK 680 M EFC SN 30 X 55	450	500	680	±20	0.20	1659	2.54	30	55	
450 MXK 680 M EFC SN 35 X 40	450	500	680	±20	0.20	1659	2.16	35	40	
450 MXK 680 M EFC SN 35 X 45	450	500	680	±20	0.20	1659	2.38	35	45	
450 MXK 820 M EFC SN 30 X 60	450	500	820	±20	0.20	1822	2.77	30	60	
450 MXK 820 M EFC SN 35 X 45	450	500	820	±20	0.20	1822	2.36	35	45	
450 MXK 820 M EFC SN 35 X 50	450	500	820	±20	0.20	1822	2.59	35	50	
450 MXK 1000 M EFC SN 35 X 55	450	500	1000	±20	0.20	2012	2.78	35	55	
450 MXK 1000 M EFC SN 35 X 60	450	500	1000	±20	0.20	2012	2.90	35	60	
475 MXK 82 M EFC SN 22 X 25	475	525	82	±20	0.25	592	0.79	22	25	*1
475 MXK 100 M EFC SN 22 X 30	475	525	100	±20	0.25	653	0.90	22	30	*1
475 MXK 100 M EFC SN 25 X 25	475	525	100	±20	0.25	653	0.90	25	25	*1
475 MXK 120 M EFC SN 22 X 30	475	525	120	±20	0.25	716	0.97	22	30	*1
475 MXK 120 M EFC SN 25 X 30	475	525	120	±20	0.25	716	1.02	25	30	*1
475 MXK 150 M EFC SN 22 X 35	475	525	150	±20	0.25	800	1.13	22	35	*1
475 MXK 150 M EFC SN 25 X 30	475	525	150	±20	0.25	800	1.12	25	30	*1
475 MXK 150 M EFC SN 30 X 25	475	525	150	±20	0.25	800	1.11	30	25	*1
475 MXK 180 M EFC SN 22 X 40	475	525	180	±20	0.25	877	1.27	22	40	*1
475 MXK 180 M EFC SN 25 X 35	475	525	180	±20	0.25	877	1.27	25	35	*1
475 MXK 180 M EFC SN 30 X 30	475	525	180	±20	0.25	877	1.27	30	30	*1
475 MXK 220 M EFC SN 22 X 45	475	525	220	±20	0.25	969	1.44	22	45	*1
475 MXK 220 M EFC SN 25 X 40	475	525	220	±20	0.25	969	1.44	25	40	*1
475 MXK 220 M EFC SN 30 X 30	475	525	220	±20	0.25	969	1.37	30	30	*1
475 MXK 220 M EFC SN 35 X 25	475	525	220	±20	0.25	969	1.27	35	25	*1
475 MXK 270 M EFC SN 22 X 55	475	525	270	±20	0.25	1074	1.68	22	55	*1
475 MXK 270 M EFC SN 25 X 45	475	525	270	±20	0.25	1074	1.63	25	45	*1
475 MXK 270 M EFC SN 30 X 35	475	525	270	±20	0.25	1074	1.56	30	35	*1
475 MXK 270 M EFC SN 35 X 30	475	525	270	±20	0.25	1074	1.51	35	30	*1
475 MXK 330 M EFC SN 25 X 50	475	525	330	±20	0.25	1187	1.83	25	50	*1
475 MXK 330 M EFC SN 30 X 40	475	525	330	±20	0.25	1187	1.77	30	40	*1

\*1: Added item

MXK SERIES	<b>Rubycon</b> RUBYCON CORPORATION	DRAWING No.	ISSUE No.
		REE-046517	5

Rubycon Part Number	Rated Voltage (V.DC)	Surge Voltage (V.DC)	Nominal Capacitance ( $\mu$ F)	Cap. Tolerance (%)	tan $\delta$ MAX.	MAX. Leakage Current ( $\mu$ A)	Rated Ripple Current (A r.m.s.) 105deg.C /120Hz	Dimension (mm)		
								$\phi$ D	L	
475 MXK 330 M EFC SN 35 X 30	475	525	330	$\pm$ 20	0.25	1187	1.57	35	30	*1
475 MXK 390 M EFC SN 25 X 60	475	525	390	$\pm$ 20	0.25	1291	2.08	25	60	*1
475 MXK 390 M EFC SN 30 X 40	475	525	390	$\pm$ 20	0.25	1291	1.85	30	40	*1
475 MXK 390 M EFC SN 35 X 35	475	525	390	$\pm$ 20	0.25	1291	1.79	35	35	*1
475 MXK 470 M EFC SN 30 X 50	475	525	470	$\pm$ 20	0.25	1417	2.17	30	50	*1
475 MXK 470 M EFC SN 35 X 40	475	525	470	$\pm$ 20	0.25	1417	2.00	35	40	*1
475 MXK 560 M EFC SN 30 X 55	475	525	560	$\pm$ 20	0.25	1547	2.38	30	55	*1
475 MXK 560 M EFC SN 35 X 45	475	525	560	$\pm$ 20	0.25	1547	2.22	35	45	*1
475 MXK 680 M EFC SN 35 X 50	475	525	680	$\pm$ 20	0.25	1704	2.45	35	50	*1
475 MXK 820 M EFC SN 35 X 60	475	525	820	$\pm$ 20	0.25	1872	2.80	35	60	*1
500 MXK 68 M EFC SN 22 X 25	500	550	68	$\pm$ 20	0.25	553	0.73	22	25	*1
500 MXK 82 M EFC SN 22 X 30	500	550	82	$\pm$ 20	0.25	607	0.83	22	30	*1
500 MXK 100 M EFC SN 22 X 30	500	550	100	$\pm$ 20	0.25	670	0.91	22	30	*1
500 MXK 120 M EFC SN 22 X 35	500	550	120	$\pm$ 20	0.25	734	1.03	22	35	*1
500 MXK 120 M EFC SN 25 X 30	500	550	120	$\pm$ 20	0.25	734	1.03	25	30	*1
500 MXK 150 M EFC SN 22 X 40	500	550	150	$\pm$ 20	0.25	821	1.18	22	40	*1
500 MXK 150 M EFC SN 25 X 30	500	550	150	$\pm$ 20	0.25	821	1.12	25	30	*1
500 MXK 180 M EFC SN 22 X 45	500	550	180	$\pm$ 20	0.25	900	1.33	22	45	*1
500 MXK 180 M EFC SN 25 X 35	500	550	180	$\pm$ 20	0.25	900	1.28	25	35	*1
500 MXK 180 M EFC SN 30 X 30	500	550	180	$\pm$ 20	0.25	900	1.28	30	30	*1
500 MXK 180 M EFC SN 35 X 25	500	550	180	$\pm$ 20	0.25	900	1.20	35	25	*1
500 MXK 220 M EFC SN 22 X 50	500	550	220	$\pm$ 20	0.25	994	1.50	22	50	*1
500 MXK 220 M EFC SN 25 X 40	500	550	220	$\pm$ 20	0.25	994	1.45	25	40	*1
500 MXK 220 M EFC SN 30 X 30	500	550	220	$\pm$ 20	0.25	994	1.36	30	30	*1
500 MXK 220 M EFC SN 35 X 30	500	550	220	$\pm$ 20	0.25	994	1.42	35	30	*1
500 MXK 270 M EFC SN 22 X 60	500	550	270	$\pm$ 20	0.25	1102	1.73	22	60	*1
500 MXK 270 M EFC SN 25 X 50	500	550	270	$\pm$ 20	0.25	1102	1.70	25	50	*1
500 MXK 270 M EFC SN 30 X 35	500	550	270	$\pm$ 20	0.25	1102	1.56	30	35	*1
500 MXK 270 M EFC SN 35 X 30	500	550	270	$\pm$ 20	0.25	1102	1.50	35	30	*1
500 MXK 330 M EFC SN 25 X 55	500	550	330	$\pm$ 20	0.25	1218	1.90	25	55	*1
500 MXK 330 M EFC SN 30 X 40	500	550	330	$\pm$ 20	0.25	1218	1.76	30	40	*1
500 MXK 330 M EFC SN 35 X 35	500	550	330	$\pm$ 20	0.25	1218	1.71	35	35	*1
500 MXK 390 M EFC SN 30 X 45	500	550	390	$\pm$ 20	0.25	1324	1.95	30	45	*1
500 MXK 390 M EFC SN 35 X 40	500	550	390	$\pm$ 20	0.25	1324	1.91	35	40	*1
500 MXK 470 M EFC SN 30 X 55	500	550	470	$\pm$ 20	0.25	1454	2.26	30	55	*1
500 MXK 470 M EFC SN 35 X 45	500	550	470	$\pm$ 20	0.25	1454	2.13	35	45	*1
500 MXK 560 M EFC SN 30 X 60	500	550	560	$\pm$ 20	0.25	1587	2.47	30	60	*1
500 MXK 560 M EFC SN 35 X 50	500	550	560	$\pm$ 20	0.25	1587	2.33	35	50	*1
500 MXK 680 M EFC SN 35 X 55	500	550	680	$\pm$ 20	0.25	1749	2.56	35	55	*1

\*1: Added item

MXK SERIES	<b>Rubycon</b> RUBYCON CORPORATION	DRAWING No.	ISSUE No.
		REE-046517	5