



# Three Terminal Voltage Regulators

## 三端稳压管

### FHP78XXB

#### 产品特性 Features

输出电压 <b>Output Voltage</b>	稳压管 Regulators
<b>5V</b>	<b>FHP7805B</b>
<b>8V</b>	<b>FHP7808B</b>
<b>9V</b>	<b>FHP7809B</b>
<b>12V</b>	<b>FHP7812B</b>
<b>15V</b>	<b>FHP7815B</b>
<b>24V</b>	<b>FHP7824B</b>
最大输出电流 <b>Max Output Current</b>	<b>1.5A</b>
过载保护 <b>Internal thermal overload prection</b>	
短路电流限制 <b>Internal short-current limiting</b>	
输出端最大安全工作区域 <b>Output transistor safe-area compensation</b>	
输出电压精度在 4%以内 <b>Output voltage offered in 4% tolerance</b>	

#### 封装形式 Package



1:Input 2:GND 3:Output

#### 功能图 Functional diagram

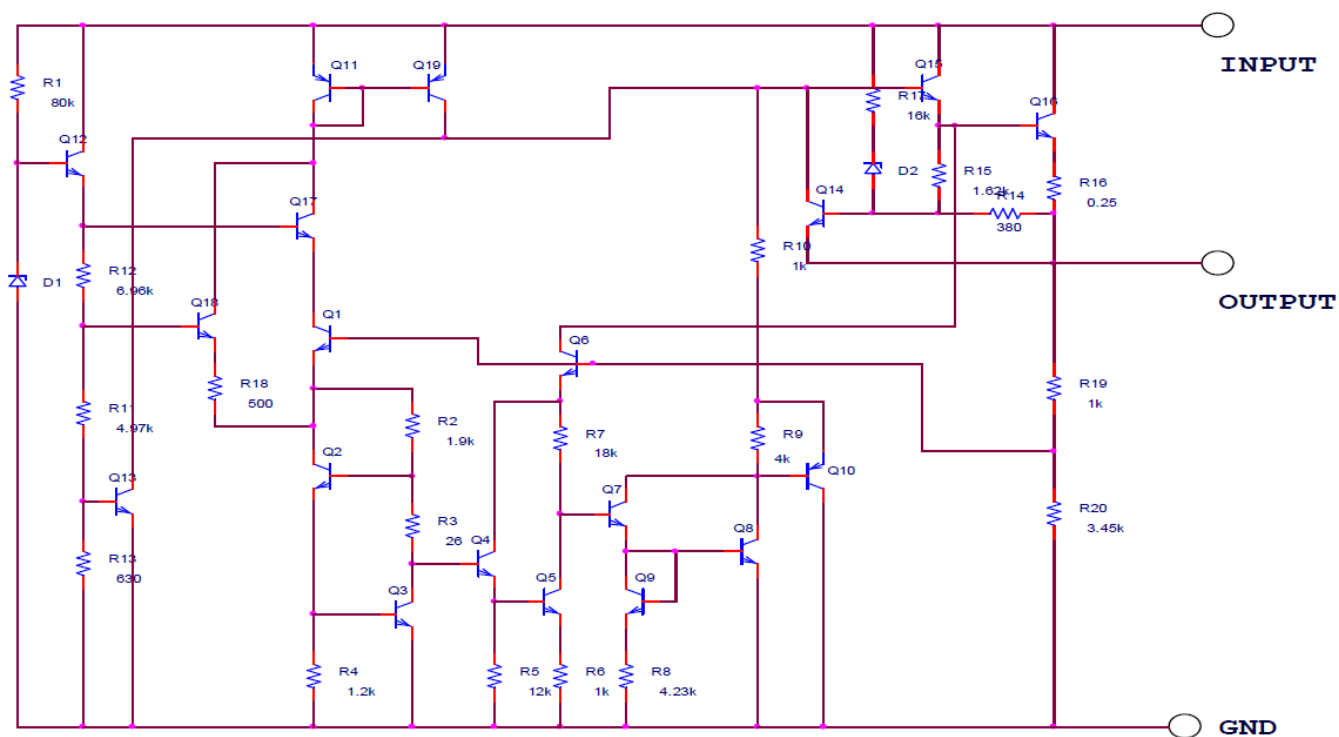

Fig.1

#### 绝对最大额定值 Absolute Maximum Rating ( $T_a = 25^\circ\text{C}$ unless otherwise noted)

Parameter 项目	Symbol 符号	Limit 极限值	Unit
输入电压 Input Voltage	$V_{in}$	for $V_o=5V$ to $V_o=18V$ for $V_o=24V$	35 40 V
功率损耗 Power Dissipation	$P_d$	Internal Limited	W
结温 Junction Temperature	$T_j$	+125	$^\circ\text{C}$
存储温度 Storage Temperature Range	$T_{STG}$	-65~+150	$^\circ\text{C}$
结-壳的热阻 Thermal Resistance -Junction to Case	$R_{\theta JC}$	5	$^\circ\text{C/W}$
结-环境的热阻 Thermal Resistance -Junction to Ambient	$R_{\theta JA}$	50	$^\circ\text{C/W}$

## FHP7805B 电参数特性 Electrical Characteristics

( $V_{in}=10V$ ,  $I_{out}=500mA$ ,  $0^{\circ}C \leq T_j \leq 125^{\circ}C$ ,  $C_{in}=0.33\mu F$ ,  $C_{out}=0.1\mu F$ ; unless otherwise specified.)

Parameter	Symbol	Test Condition	Min	Typ	Max	Unit	
输出电压 Output voltage	Vout	$T_j=25^{\circ}C$	4.80	5	5.20	V	
		$7.5V \leq V_{in} \leq 20V$ , $5mA \leq I_{out} \leq 1A$ , $PD \leq 15W$	4.75	5	5.25		
线性调节 Line Regulation	REGline	$T_j=25^{\circ}C$	$7.5V \leq V_{in} \leq 25V$	--	5	50	mV
			$8V \leq V_{in} \leq 12V$	--	2	25	
负载调节 Load Regulation	REGload	$T_j=25^{\circ}C$	$5mA \leq I_{out} \leq 1.5A$	--	25	50	
			$250mA \leq I_{out} \leq 750mA$	--	10	25	
静态电流 Quiescent Current	Iq	$I_{out}=0$ , $T_j=25^{\circ}C$	--	4.0	8	mA	
静态电流变化 Quiescent Current Change	$\Delta Iq$	$8.0V \leq V_{in} \leq 25V$	--	--	0.8		
		$5mA \leq I_{out} \leq 1A$	--	--	0.5		
输出电压纹波 Output Noise Voltage	Vn	$10Hz \leq f \leq 100KHz$ , $T_j=25^{\circ}C$	--	42	--	$\mu V$	
浪涌衰减 Ripple Rejection Ratio	RR	$f=120Hz$ , $8V \leq V_{in} \leq 18V$	62	73	--	dB	
衰减电压 Voltage Drop	Vdrop	$I_{out}=1A$ , $T_j=25^{\circ}C$	--	2	--	V	
短路电流 Output Short Circuit Current	Ios	$T_j=25^{\circ}C$	--	200	--	mA	
峰值电流 Peak Output Current	I <sub>o peak</sub>	$T_j=25^{\circ}C$	--	2.2	--	A	
输出电压特性 Temperature Coefficient of Output Voltage	$\Delta V_{out} / \Delta T_j$	$I_{out}=5mA$ , $0^{\circ}C \leq T_j \leq 125^{\circ}C$	--	-0.2	--	$mV/^{\circ}C$	
输出端电阻 Output resistance	Ro	$f=1KHz$	--	15	--	$m\Omega$	

## FHP7808B 电参数特性 Electrical Characteristics

( $V_{in}=14V$ ,  $I_{out}=500mA$ ,  $0^{\circ}C \leq T_j \leq 125^{\circ}C$ ,  $C_{in}=0.33\mu F$ ,  $C_{out}=0.1\mu F$ ; unless otherwise specified.)

Parameter	Symbol	Test Condition	Min	Typ	Max	Unit	
输出电压 Output voltage	Vout	$T_j=25^{\circ}C$	7.7	8.0	8.3	V	
		$11V \leq V_{in} \leq 23V$ , $5mA \leq I_{out} \leq 1A$ , $PD \leq 15W$	7.6	8.0	8.4		
线性调节 Line Regulation	REGline	$T_j=25^{\circ}C$	$10.5V \leq V_{in} \leq 25V$	--	8.0	80	mV
			$11V \leq V_{in} \leq 17V$	--	3.0	40	
负载调节 Load Regulation	REGload	$T_j=25^{\circ}C$	$5mA \leq I_{out} \leq 1.5A$	--	30	80	
			$250mA \leq I_{out} \leq 750mA$	--	10	40	
静态电流 Quiescent Current	Iq	$I_{out}=0$ , $T_j=25^{\circ}C$	--	5.0	8	mA	
静态电流变化 Quiescent Current Change	$\Delta Iq$	$11V \leq V_{in} \leq 25V$	--	--	0.8		
		$5mA \leq I_{out} \leq 1A$	--	--	0.5		
输出电压纹波 Output Noise Voltage	Vn	$10Hz \leq f \leq 100KHz$ , $T_j=25^{\circ}C$	--	52	--	$\mu V$	
浪涌衰减 Ripple Rejection Ratio	RR	$f=120Hz$ , $11.5V \leq V_{in} \leq 21.5V$	56	73	--	dB	
衰减电压 Voltage Drop	Vdrop	$I_{out}=1A$ , $T_j=25^{\circ}C$	--	2	--	V	
短路电流 Output Short Circuit Current	Ios	$T_j=25^{\circ}C$	--	200	--	mA	
峰值电流 Peak Output Current	I <sub>o peak</sub>	$T_j=25^{\circ}C$	--	2.2	--	A	
输出电压特性 Temperature Coefficient of Output Voltage	$\Delta V_{out} / \Delta T_j$	$I_{out}=5mA$ , $0^{\circ}C \leq T_j \leq 125^{\circ}C$	--	-0.2	--	$mV/^{\circ}C$	
输出端电阻 Output resistance	Ro	$f=1KHz$	--	17	--	$m\Omega$	

## FHP7809B 电参数特性 Electrical Characteristics

( $V_{in}=15V$ ,  $I_{out}=500mA$ ,  $0^{\circ}C \leq T_j \leq 125^{\circ}C$ ,  $C_{in}=0.33\mu F$ ,  $C_{out}=0.1\mu F$ ; unless otherwise specified.)

Parameter	Symbol	Test Condition	Min	Typ	Max	Unit	
输出电压 Output voltage	Vout	$T_j=25^{\circ}C$	8.65	9.0	9.35	V	
		$11.5V \leq V_{in} \leq 24V$ , $5mA \leq I_{out} \leq 1A$ , $PD \leq 15W$	8.6	9.0	9.4		
线性调节 Line Regulation	REGline	$T_j=25^{\circ}C$	$11.5V \leq V_{in} \leq 25V$	--	8.0	90	mV
			$12V \leq V_{in} \leq 17V$	--	3.0	45	
负载调节 Load Regulation	REGload	$T_j=25^{\circ}C$	$5mA \leq I_{out} \leq 1.5A$	--	30	90	
			$250mA \leq I_{out} \leq 750mA$	--	10	45	
静态电流 Quiescent Current	Iq	$I_{out}=0$ , $T_j=25^{\circ}C$	--	4.0	8	mA	
静态电流变化 Quiescent Current Change	$\Delta Iq$	$12V \leq V_{in} \leq 26V$	--	--	0.8		
		$5mA \leq I_{out} \leq 1A$	--	--	0.5		
输出电压纹波 Output Noise Voltage	Vn	$10Hz \leq f \leq 100KHz$ , $T_j=25^{\circ}C$	--	58	--	$\mu V$	
浪涌衰减 Ripple Rejection Ratio	RR	$f=120Hz$ , $11.5V \leq V_{in} \leq 21.5V$	56	73	--	dB	
衰减电压 Voltage Drop	Vdrop	$I_{out}=1A$ , $T_j=25^{\circ}C$	--	2	--	V	
短路电流 Output Short Circuit Current	Ios	$T_j=25^{\circ}C$	--	200	--	mA	
峰值电流 Peak Output Current	I <sub>o peak</sub>	$T_j=25^{\circ}C$	--	2.2	--	A	
输出电压特性 Temperature Coefficient of Output Voltage	$\Delta V_{out} / \Delta T_j$	$I_{out}=5mA$ , $0^{\circ}C \leq T_j \leq 125^{\circ}C$	--	-0.2	--	$mV/^{\circ}C$	
输出端电阻 Output resistance	Ro	$f=1KHz$	--	15	--	$m\Omega$	

## FHP7812B 电参数特性 Electrical Characteristics

( $V_{in}=19V$ ,  $I_{out}=500mA$ ,  $0^{\circ}C \leq T_j \leq 125^{\circ}C$ ,  $C_{in}=0.33\mu F$ ,  $C_{out}=0.1\mu F$ ; unless otherwise specified.)

Parameter	Symbol	Test Condition	Min	Typ	Max	Unit	
输出电压 Output voltage	Vout	$T_j=25^{\circ}C$	11.5	12.0	12.5	V	
		$14.5V \leq V_{in} \leq 27V$ , $5mA \leq I_{out} \leq 1A$ , $PD \leq 15W$	11.4	12.0	12.6		
线性调节 Line Regulation	REGline	$T_j=25^{\circ}C$	$14.5V \leq V_{in} \leq 30V$	--	10	120	mV
			$16V \leq V_{in} \leq 22V$	--	3	60	
负载调节 Load Regulation	REGload	$T_j=25^{\circ}C$	$5mA \leq I_{out} \leq 1.5A$	--	30	120	
			$250mA \leq I_{out} \leq 750mA$	--	10	60	
静态电流 Quiescent Current	Iq	$I_{out}=0$ , $T_j=25^{\circ}C$	--	4.0	8	mA	
静态电流变化 Quiescent Current Change	$\Delta Iq$	$15V \leq V_{in} \leq 30V$	--	--	0.8		
		$5mA \leq I_{out} \leq 1A$	--	--	0.5		
输出电压纹波 Output Noise Voltage	Vn	$10Hz \leq f \leq 100KHz$ , $T_j=25^{\circ}C$	--	76	--	$\mu V$	
浪涌衰减 Ripple Rejection Ratio	RR	$f=120Hz$ , $15V \leq V_{in} \leq 25V$	55	71	--	dB	
衰减电压 Voltage Drop	Vdrop	$I_{out}=1A$ , $T_j=25^{\circ}C$	--	2	--	V	
短路电流 Output Short Circuit Current	Ios	$T_j=25^{\circ}C$	--	200	--	mA	
峰值电流 Peak Output Current	I <sub>o peak</sub>	$T_j=25^{\circ}C$	--	2.2	--	A	
输出电压特性 Temperature Coefficient of Output Voltage	$\Delta V_{out} / \Delta T_j$	$I_{out}=5mA$ , $0^{\circ}C \leq T_j \leq 125^{\circ}C$	--	-0.2	--	$mV/^{\circ}C$	
输出端电阻 Output resistance	Ro	$f=1KHz$	--	18	--	$m\Omega$	

## FHP7815B 电参数特性 Electrical Characteristics

( $V_{in}=23V$ ,  $I_{out}=500mA$ ,  $0^{\circ}C \leq T_j \leq 125^{\circ}C$ ,  $C_{in}=0.33\mu F$ ,  $C_{out}=0.1\mu F$ ; unless otherwise specified.)

Parameter	Symbol	Test Condition	Min	Typ	Max	Unit	
输出电压 Output voltage	Vout	$T_j=25^{\circ}C$	14.4	15.0	15.6	V	
		$17.5V \leq V_{in} \leq 30V$ , $5mA \leq I_{out} \leq 1A$ , $PD \leq 15W$	14.25	15.0	15.75		
线性调节 Line Regulation	REGline	$T_j=25^{\circ}C$	$17.5V \leq V_{in} \leq 30V$	--	12	150	mV
			$20V \leq V_{in} \leq 26V$	--	5	75	
负载调节 Load Regulation	REGload	$T_j=25^{\circ}C$	$5mA \leq I_{out} \leq 1.5A$	--	35	150	
			$250mA \leq I_{out} \leq 750mA$	--	10	75	
静态电流 Quiescent Current	Iq	$I_{out}=0$ , $T_j=25^{\circ}C$	--	4.0	8	mA	
静态电流变化 Quiescent Current Change	$\Delta Iq$	$18V \leq V_{in} \leq 30.5V$	--	--	0.8		
		$5mA \leq I_{out} \leq 1A$	--	--	0.5		
输出电压纹波 Output Noise Voltage	Vn	$10Hz \leq f \leq 100KHz$ , $T_j=25^{\circ}C$	--	90	--	$\mu V$	
浪涌衰减 Ripple Rejection Ratio	RR	$f=120Hz$ , $18.5V \leq V_{in} \leq 28.5V$	54	70	--	dB	
衰减电压 Voltage Drop	Vdrop	$I_{out}=1A$ , $T_j=25^{\circ}C$	--	2	--	V	
短路电流 Output Short Circuit Current	Ios	$T_j=25^{\circ}C$	--	200	--	mA	
峰值电流 Peak Output Current	I <sub>o peak</sub>	$T_j=25^{\circ}C$	--	2.2	--	A	
输出电压特性 Temperature Coefficient of Output Voltage	$\Delta V_{out} / \Delta T_j$	$I_{out}=5mA$ , $0^{\circ}C \leq T_j \leq 125^{\circ}C$	--	-0.2	--	$mV/^{\circ}C$	
输出端电阻 Output resistance	Ro	$f=1KHz$	--	19	--	$m\Omega$	

## FHP7824B 电参数特性 Electrical Characteristics

( $V_{in}=33V$ ,  $I_{out}=500mA$ ,  $0^{\circ}C \leq T_j \leq 125^{\circ}C$ ,  $C_{in}=0.33\mu F$ ,  $C_{out}=0.1\mu F$ ; unless otherwise specified.)

Parameter	Symbol	Test Condition	Min	Typ	Max	Unit	
输出电压 Output voltage	Vout	$T_j=25^{\circ}C$	23	24	25	V	
		$27V \leq V_{in} \leq 38V$ , $5mA \leq I_{out} \leq 1A$ , $PD \leq 15W$	22.8	24	25.2		
线性调节 Line Regulation	REGline	$T_j=25^{\circ}C$	$27V \leq V_{in} \leq 38V$	--	15	240	mV
			$30V \leq V_{in} \leq 36V$	--	6	120	
负载调节 Load Regulation	REGload	$T_j=25^{\circ}C$	$5mA \leq I_{out} \leq 1.5A$	--	35	240	
			$250mA \leq I_{out} \leq 750mA$	--	10	120	
静态电流 Quiescent Current	Iq	$I_{out}=0$ , $T_j=25^{\circ}C$	--	4.0	8	mA	
静态电流变化 Quiescent Current Change	$\Delta Iq$	$27V \leq V_{in} \leq 38V$	--	--	1.0		
		$5mA \leq I_{out} \leq 1A$	--	--	0.5		
输出电压纹波 Output Noise Voltage	Vn	$10Hz \leq f \leq 100KHz$ , $T_j=25^{\circ}C$	--	160	--	$\mu V$	
浪涌衰减 Ripple Rejection Ratio	RR	$f=120Hz$ , $28V \leq V_{in} \leq 38V$	50	67	--	dB	
衰减电压 Voltage Drop	Vdrop	$I_{out}=1A$ , $T_j=25^{\circ}C$	--	2	--	V	
短路电流 Output Short Circuit Current	Ios	$T_j=25^{\circ}C$	--	200	--	mA	
峰值电流 Peak Output Current	I <sub>o peak</sub>	$T_j=25^{\circ}C$	--	2.2	--	A	
输出电压特性 Temperature Coefficient of Output Voltage	$\Delta V_{out} / \Delta T_j$	$I_{out}=5mA$ , $0^{\circ}C \leq T_j \leq 125^{\circ}C$	--	-0.2	--	$mV/^{\circ}C$	
输出端电阻 Output resistance	Ro	$f=1KHz$	--	28	--	$m\Omega$	

## 测试电路 Test Circuits

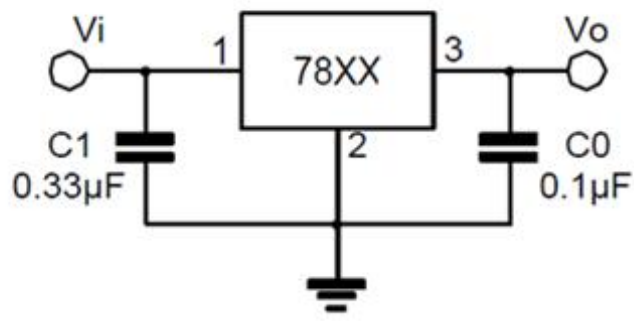

FIG.2 DC PARAMETERS

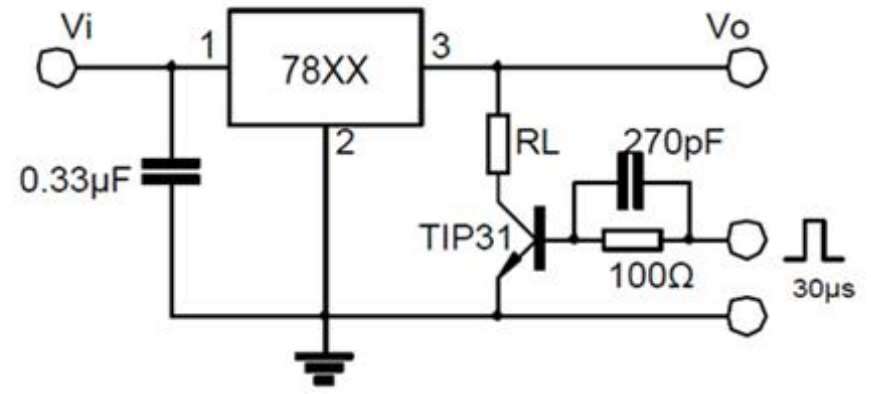

FIG.3 LOAD REGULATION

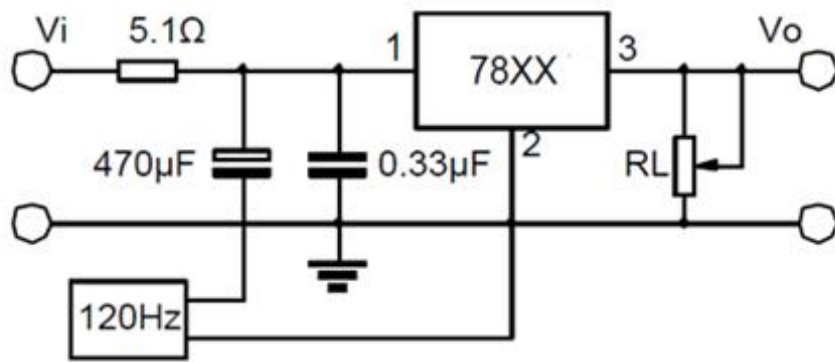

FIG.4 RIPPLE REJECTION

# 典型应用电路 Typical application circuit

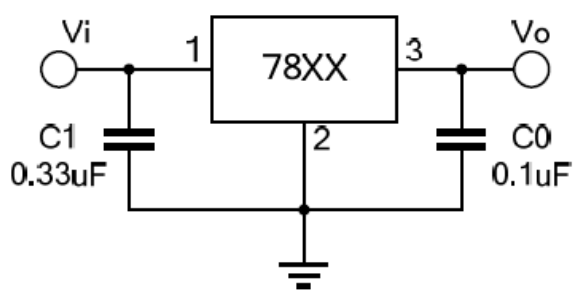

Fig.5 Fixed output regulator

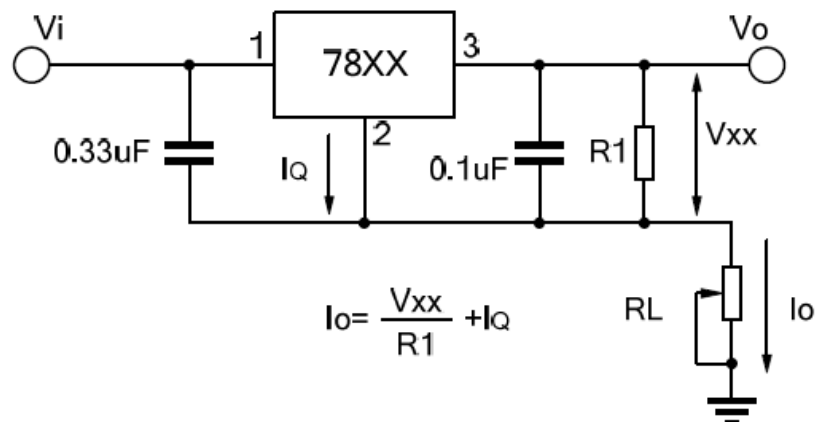

Fig.6 Constant current regulator

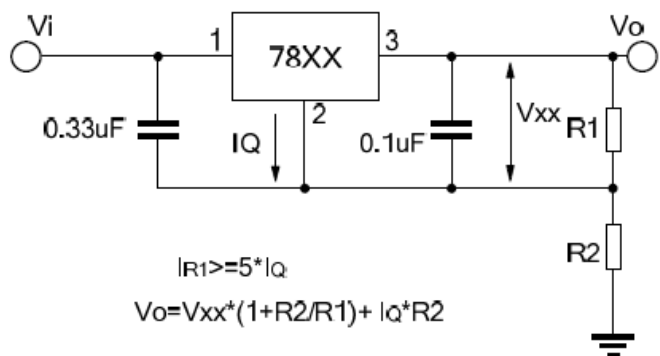

Fig.7 Circuit for increasing Regulator output voltage

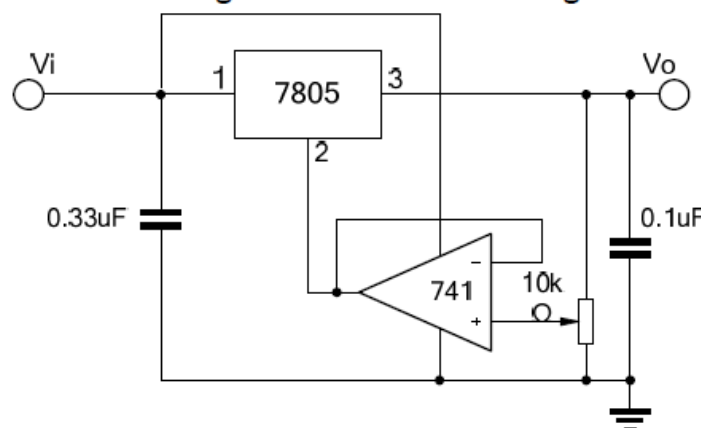
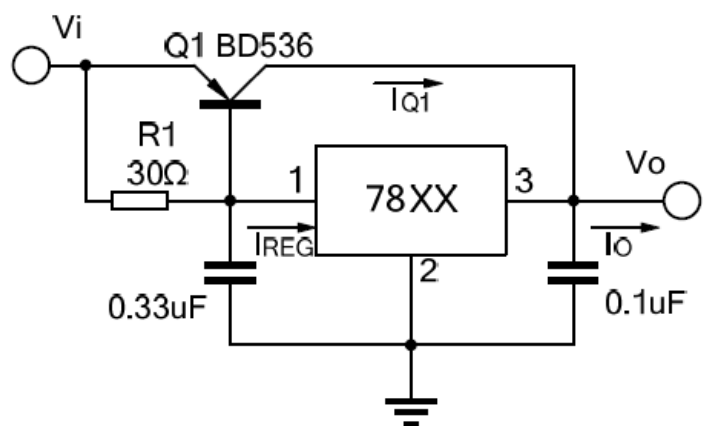

Fig.8 Adjustable output



$$I_o = I_{REG} \cdot (I_{REG} - V_{BEQ1}/R_1)$$

$$R_1 = V_{BEQ1}/(I_{REG} - I_{Q1} \cdot Q_1)$$

Fig.9.1 High current with voltage regulator

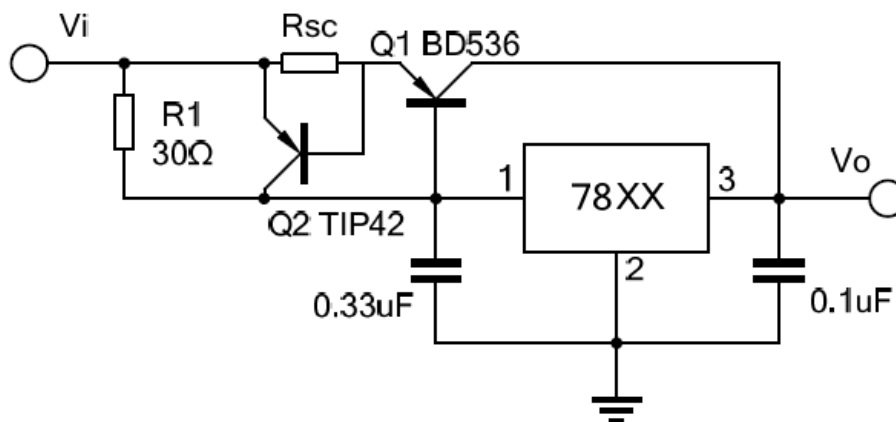

$$R_{sc} = V_{BEQ2}/I_{sc}$$

Fig.9.2 High output current short circuit protection

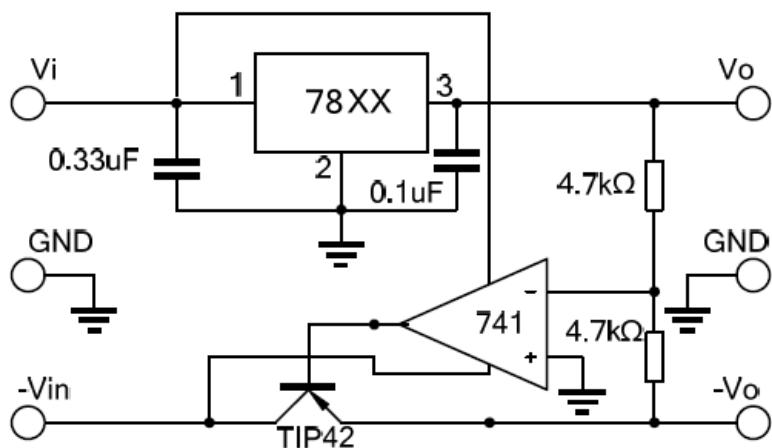

Fig.10 Tracking voltage regulator

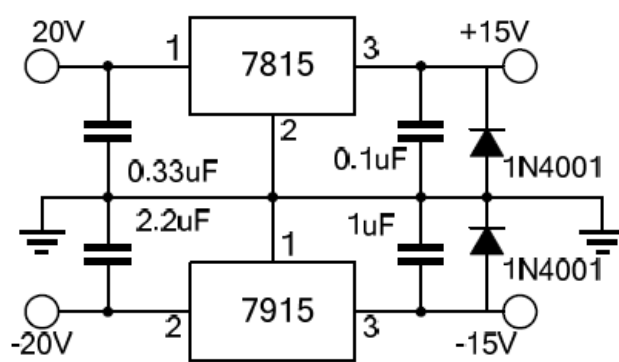

Fig.11 Split power supply (\$\pm 15\text{V}, 1\text{A}\$)

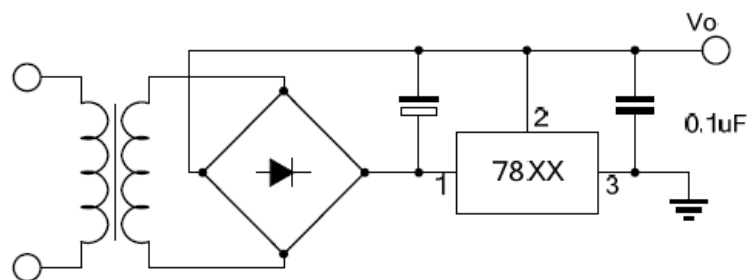

Fig.12 Negative output voltage circuit

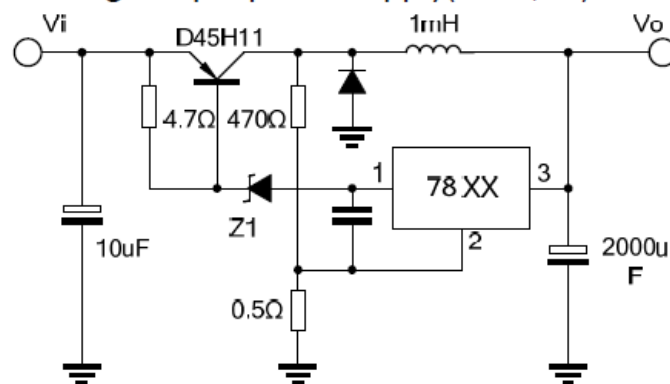

Fig.13 switching regulator

# 典型特性曲线 Typical performance characteristics

Fig.14 Quiescent current

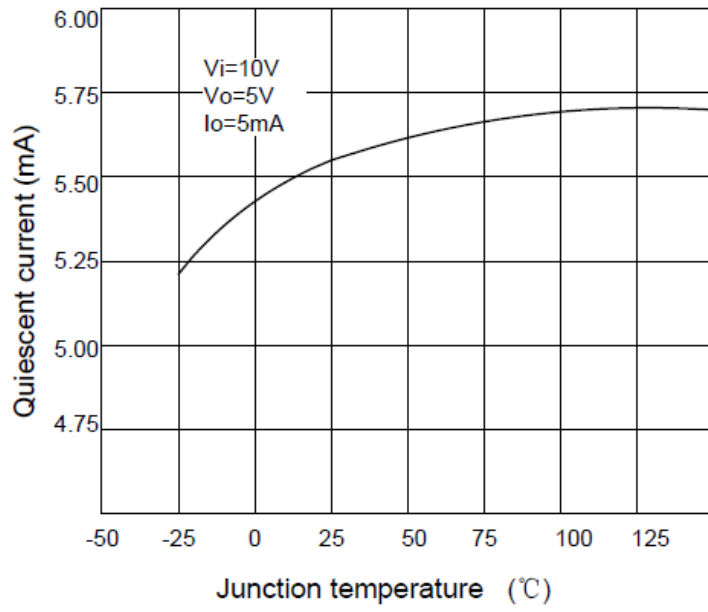

Fig.15 Output voltage

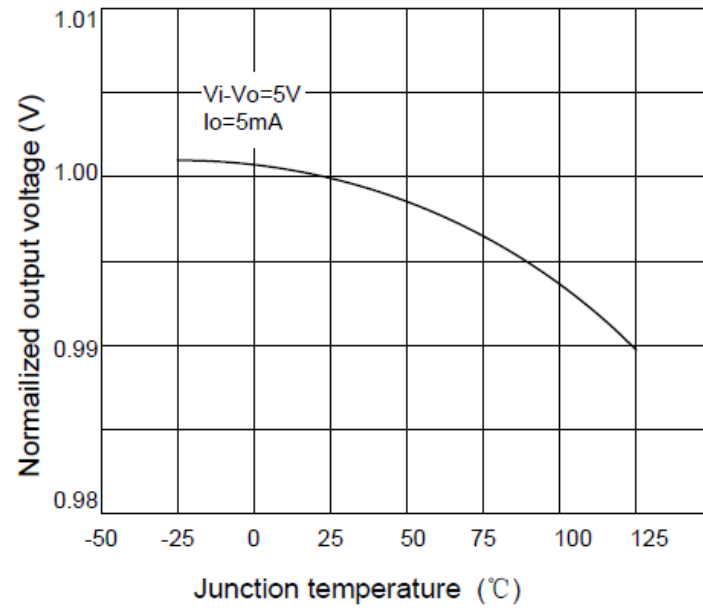

Fig.16 Peak output current

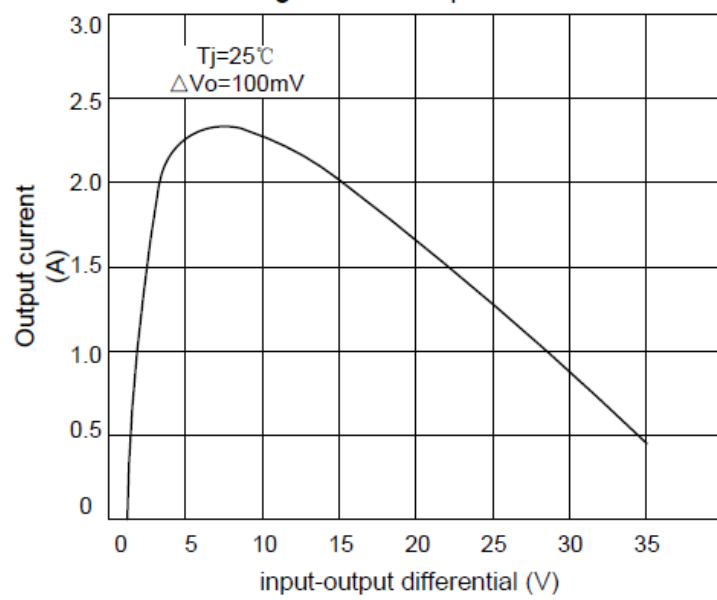
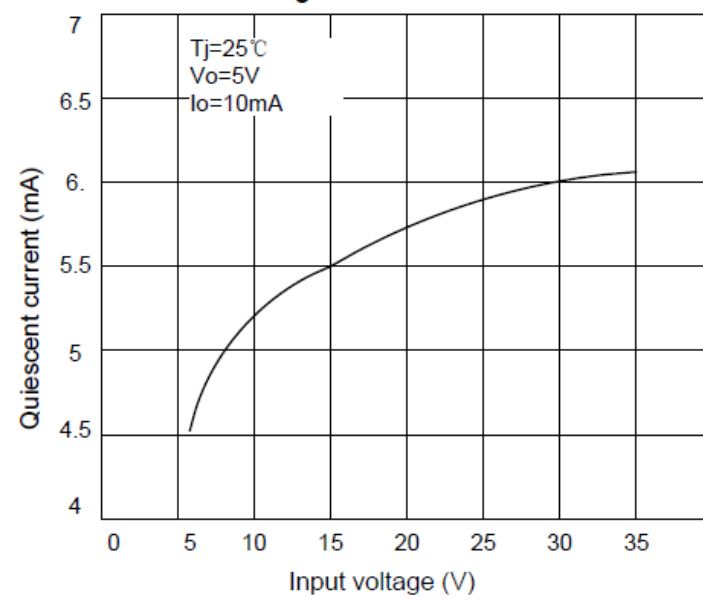
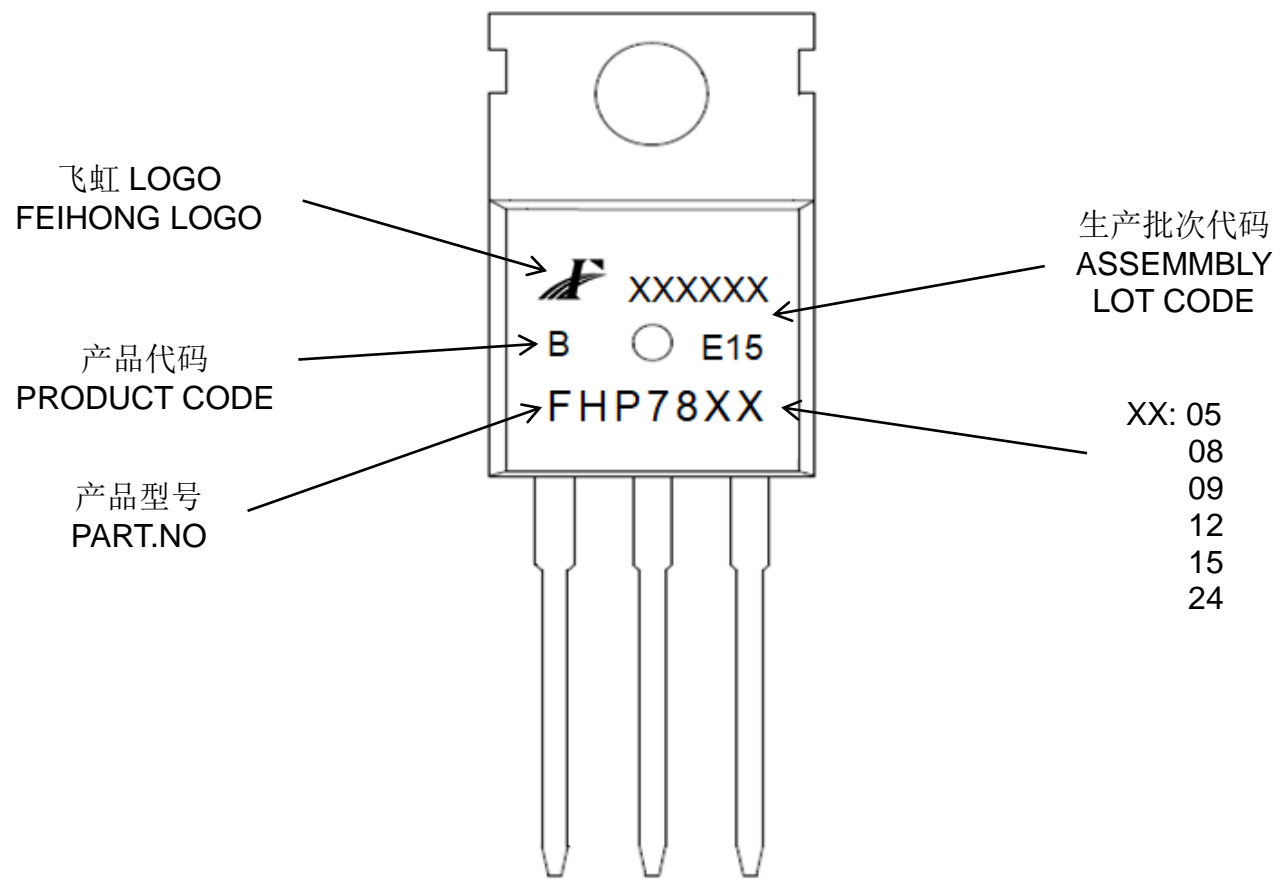

Fig.17 Quiescent current



印记 Marking:





外形尺寸:

Package Dimension:

TO-220

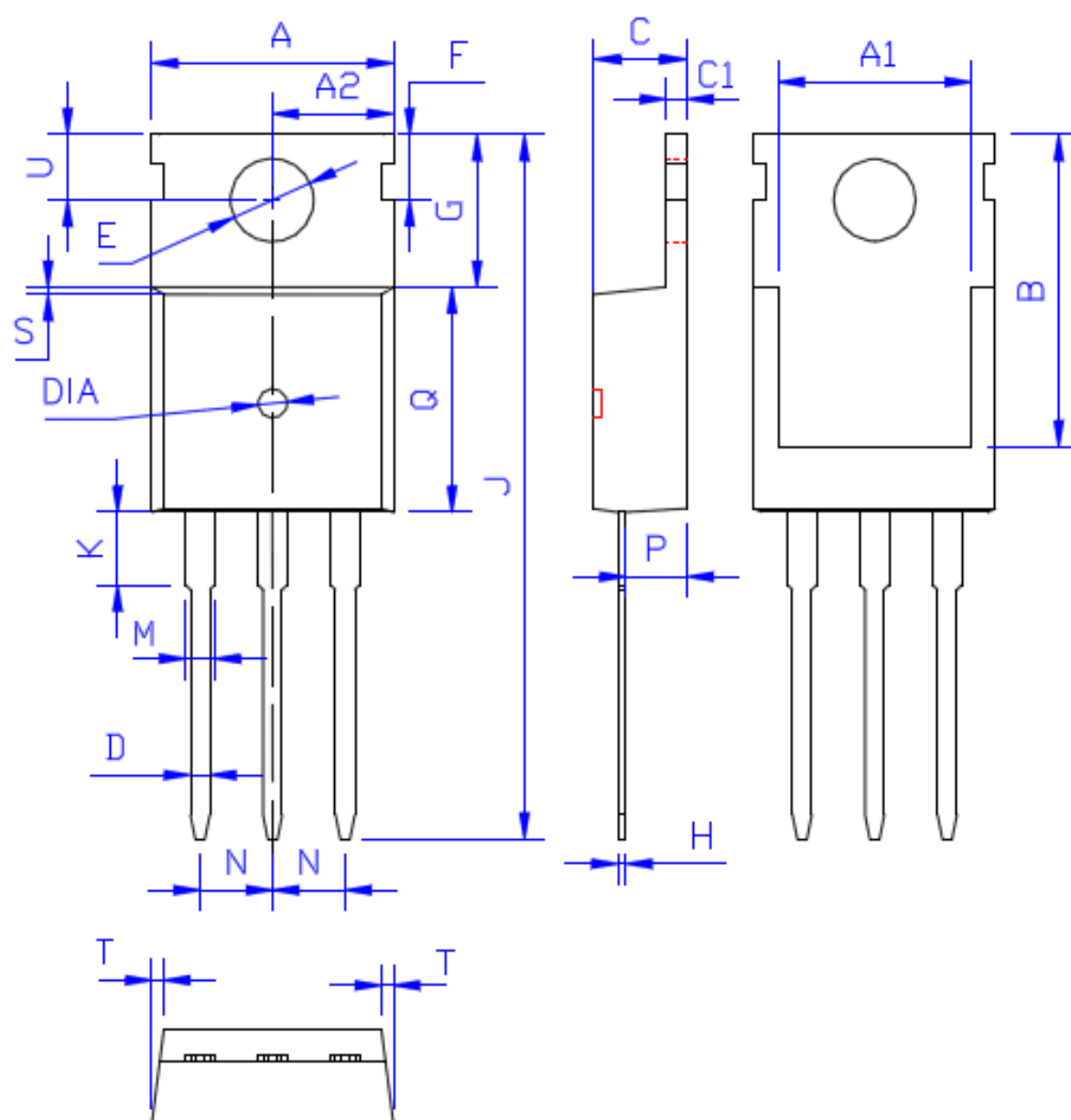

DIM	MILLIMETERS
A	10.00 ± 0.30
A1	8.00 ± 0.30
A2	5.00 ± 0.30
B	13.20 ± 0.40
C	4.50 ± 0.20
C1	1.30 ± 0.20
D	0.80 ± 0.20
E	3.60 ± 0.20
F	3.00 ± 0.30
G	6.60 ± 0.40
H	0.50 ± 0.20
J	28.88 ± 0.50
K	3.00 ± 0.30
M	1.30 ± 0.30
N	Typical 2.54
P	2.40 ± 0.40
Q	9.20 ± 0.40
S	0.25 ± 0.15
T	0.25 ± 0.15
U	2.80 ± 0.30
DIA	宽 1.50 ± 0.10 深 0.50 MAX

(Unit: mm)