



PCA9501

8-bit I²C-bus and SMBus I/O port with interrupt, 2-kbit EEPROM and 6 address pins

Rev. 04 — 10 February 2009

Product data sheet

1. General description

The PCA9501 is an 8-bit I/O expander with an on-board 2-kbit EEPROM.

The I/O expandable eight quasi-bidirectional data pins can be independently assigned as inputs or outputs to monitor board level status or activate indicator devices such as LEDs. The system master writes to the I/O configuration bits in the same way as for the PCF8574. The data for each input or output is kept in the corresponding input or output register. The system master can read all registers.

The EEPROM can be used to store error codes or board manufacturing data for read-back by application software for diagnostic purposes and are included in the I/O expander package.

The PCA9501 active LOW open-drain interrupt output is activated when any input state differs from its corresponding input port register state. It is used to indicate to the system master that an input state has changed and the device needs to be interrogated.

The PCA9501 has six address pins with internal pull-up resistors allowing up to 64 devices to share the common two-wire I²C-bus software protocol serial data bus. The fixed GPIO address starts with '0' and the fixed EEPROM I²C-bus address starts with '1', so the PCA9501 appears as two separate devices to the bus master.

The PCA9501 supports hot insertion to facilitate usage in removable cards on backplane systems.

2. Features

- 8 general purpose input/output expander/collector
- Replacement for PCF8574 with integrated 2-kbit EEPROM
- Internal 256 × 8 EEPROM
- Self timed write cycle (5 ms typical)
- 16 byte page write operation
- I²C-bus and SMBus interface logic
- Internal power-on reset
- Noise filter on SCL/SDA inputs
- Active LOW interrupt output
- 6 address pins allowing up to 64 devices on the I²C-bus/SMBus
- No glitch on power-up
- Supports hot insertion
- Power-up with all channels configured as inputs

- Low standby current
- Operating power supply voltage range of 2.5 V to 3.6 V
- 5 V tolerant inputs/outputs
- 0 Hz to 400 kHz clock frequency
- ESD protection exceeds 2000 V HBM per JESD22-A114, 200 V MM per JESD22-A115 and 1000 V CDM per JESD22-C101
- Latch-up testing is done to JEDEC Standard JESD78 which exceeds 100 mA
- Packages offered: SO20, TSSOP20, HVQFN20

3. Applications

- Board version tracking and configuration
- Board health monitoring and status reporting
- Multi-card systems in telecom, networking, and base station infrastructure equipment
- Field recall and troubleshooting functions for installed boards
- General-purpose integrated I/O with memory
- Replacement for PCF8574 with integrated 2-kbit EEPROM
- Bus master sees GPIO and EEPROM as two separate devices
- Six hardware address pins allow up to 64 PCA9501s to be located in the same I²C-bus/SMBus

4. Ordering information

Table 1. Ordering information

Type number	Package		
	Name	Description	Version
PCA9501D	SO20	plastic small outline package; 20 leads; body width 7.5 mm	SOT163-1
PCA9501PW	TSSOP20	plastic thin shrink small outline package; 20 leads; body width 4.4 mm	SOT360-1
PCA9501BS	HVQFN20	plastic thermal enhanced very thin quad flat package; no leads; 20 terminals; body 5 × 5 × 0.85 mm	SOT662-1

4.1 Ordering options

Table 2. Ordering options

Type number	Topside mark	Temperature range
PCA9501D	PCA9501D	-40 °C to +85 °C
PCA9501PW	PCA9501	-40 °C to +85 °C
PCA9501BS	9501	-40 °C to +85 °C

5. Block diagram

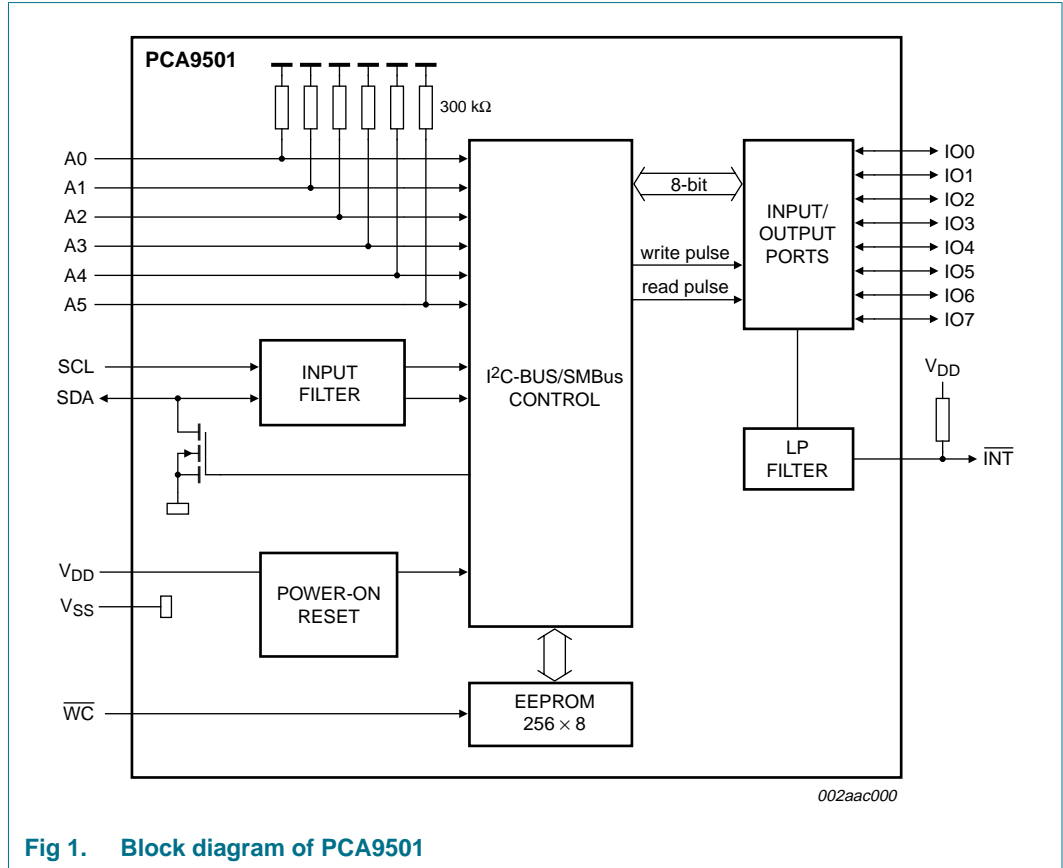

Fig 1. Block diagram of PCA9501

6. Pinning information

6.1 Pinning

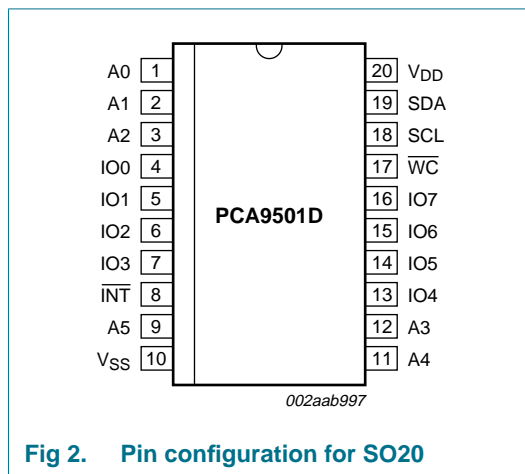

Fig 2. Pin configuration for SO20

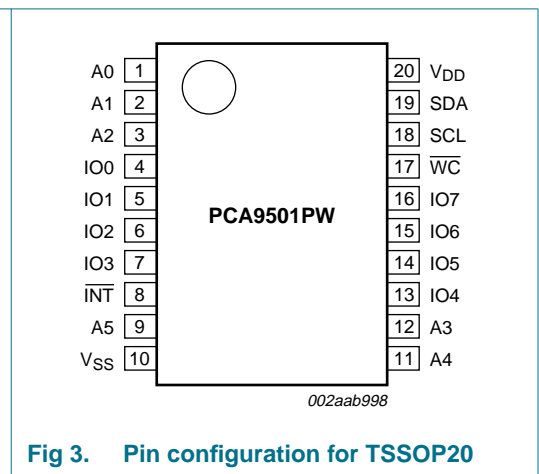

Fig 3. Pin configuration for TSSOP20

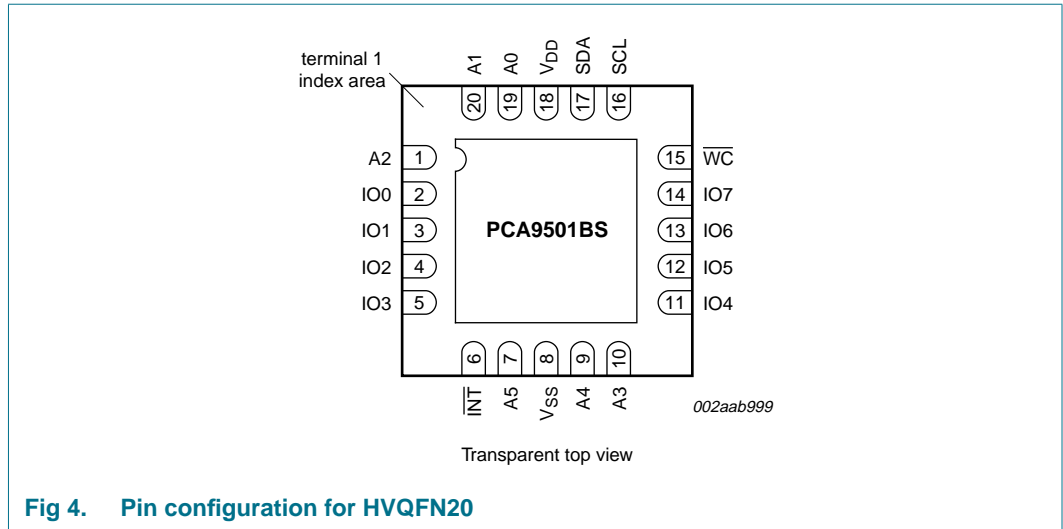

Fig 4. Pin configuration for HVQFN20

6.2 Pin description

Table 3. Pin description

Symbol	Pin		Description
	SO20, TSSOP20	HVQFN20	
A0	1	19	address lines (internal pull-up)
A1	2	20	
A2	3	1	
A3	12	10	
A4	11	9	
A5	9	7	
IO0	4	2	quasi-bidirectional I/O pins
IO1	5	3	
IO2	6	4	
IO3	7	5	
IO4	13	11	
IO5	14	12	
IO6	15	13	
IO7	16	14	
INT	8	6	active LOW interrupt output (open-drain)
V _{SS}	10	8 ^[1]	supply ground
WC	17	15	active LOW write control pin
SCL	18	16	I ² C-bus serial clock
SDA	19	17	I ² C-bus serial data
V _{DD}	20	18	supply voltage

[1] HVQFN20 package die supply ground is connected to both V_{SS} pin and exposed center pad. V_{SS} pin must be connected to supply ground for proper device operation. For enhanced thermal, electrical, and board level performance, the exposed pad needs to be soldered to the board using a corresponding thermal pad on the board and for proper heat conduction through the board, thermal vias need to be incorporated in the printed-circuit board in the thermal pad region.

7. Functional description

Refer also to [Figure 1 “Block diagram of PCA9501”](#).

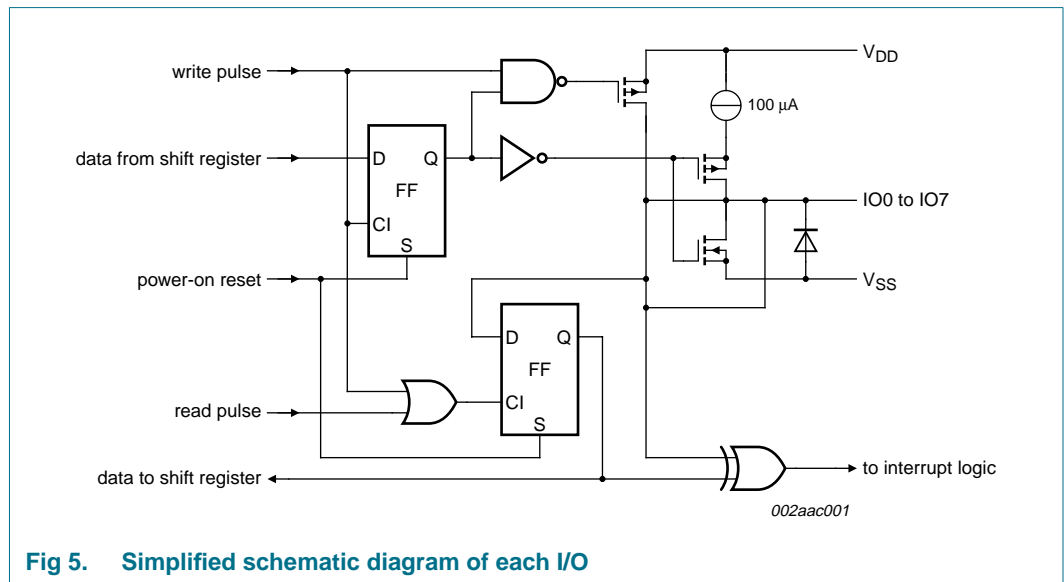

Fig 5. Simplified schematic diagram of each I/O

7.1 Device addressing

Following a START condition, the bus master must output the address of the slave it is accessing. The address of the PCA9501 is shown in [Figure 6](#). Internal pull-up resistors are incorporated on the hardware-selectable address pins.

The last bit of the address byte defines the operation to be performed. When set to logic 1 a read is selected, while a logic 0 selects a write operation.

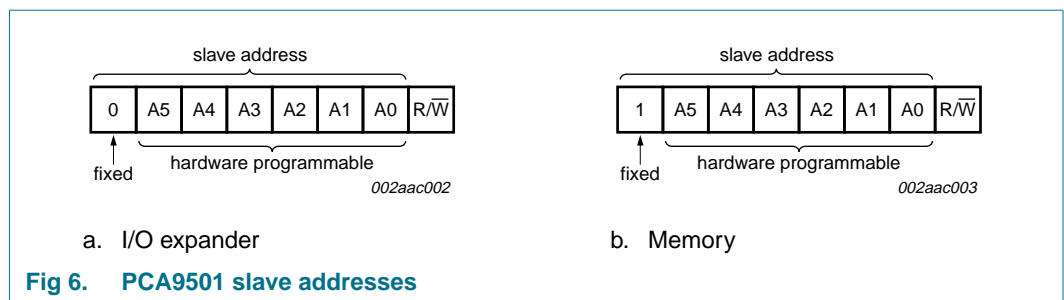

Fig 6. PCA9501 slave addresses

Remark: Reserved I²C-bus addresses must be used with caution since they can interfere with:

- Reserved for future use I²C-bus addresses (0000 011, 1111 1xx)
- Slave devices that use the 10-bit addressing scheme (1111 0xx)
- Slave devices that are designed to respond to the General Call address (0000 000)
- Hs-mode master code (0000 1xx)

7.2 Control register

The PCA9501 contains a single 8-bit register called the Control register, which can be written and read via the I²C-bus. This register is sent after a successful acknowledgment of the slave address.

It contains the I/O operation information.

7.3 I/O operations

(Refer also to [Figure 5](#).)

Each of the PCA9501's eight I/Os can be independently used as an input or output. Output data is transmitted to the port by the I/O Write mode (see [Figure 7](#)). Input I/O data is transferred from the port to the microcontroller by the Read mode (see [Figure 8](#)).

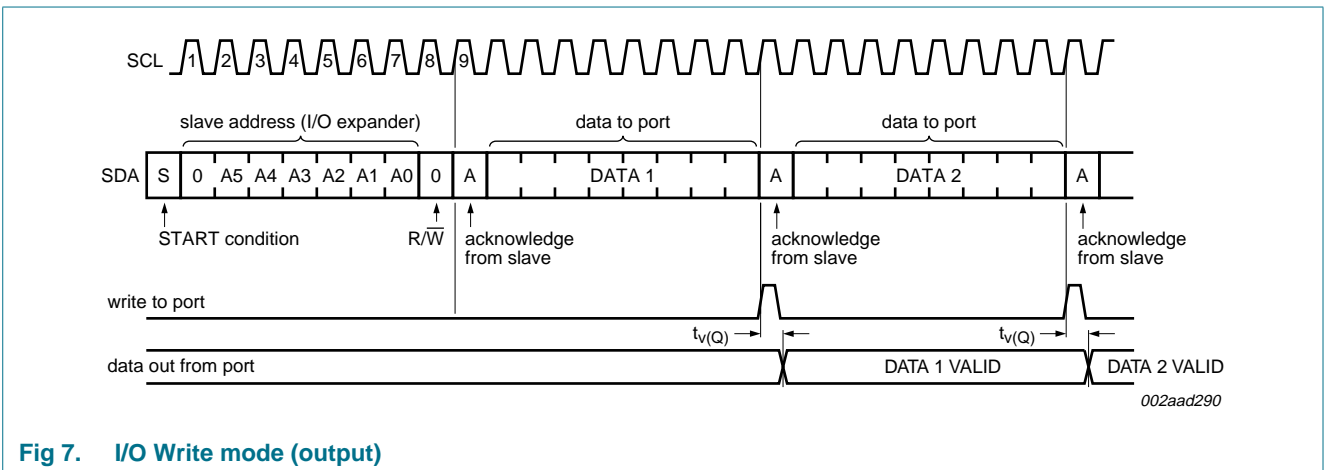

Fig 7. I/O Write mode (output)

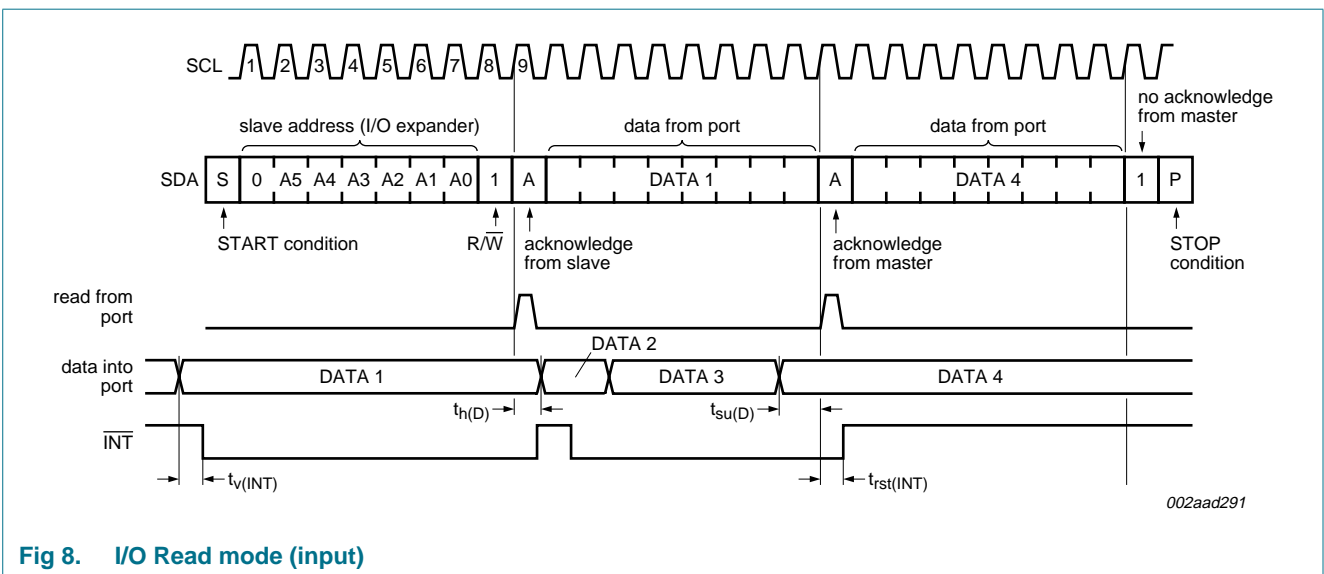

Fig 8. I/O Read mode (input)

7.3.1 Quasi-bidirectional I/Os

A quasi-bidirectional I/O can be used as an input or output without the use of a control signal for data direction. At power-on the I/Os are HIGH. In this mode, only a current source to V_{DD} is active. An additional strong pull-up to V_{DD} allows fast rising edges into heavily loaded outputs. These devices turn on when an output is written HIGH, and are switched off by the negative edge of SCL. The I/Os should be HIGH before being used as inputs. See [Figure 9](#).

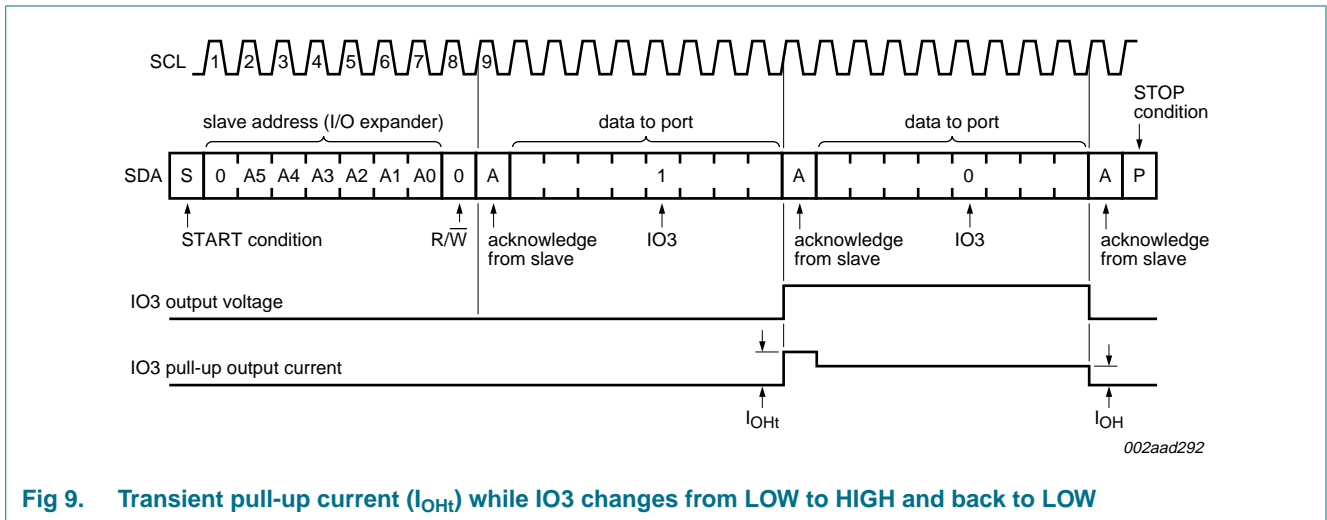

Fig 9. Transient pull-up current (I_{OHt}) while IO3 changes from LOW to HIGH and back to LOW

7.3.2 Interrupt

The PCA9501 provides an open-drain output (\overline{INT}) which can be fed to a corresponding input of the microcontroller. This gives these chips a type of master function which can initiate an action elsewhere in the system. See [Figure 10](#).

An interrupt is generated by any rising or falling edge of the port inputs in the input mode. After time $t_{V(INT)}$ the signal \overline{INT} is valid. See [Figure 11](#).

Resetting and reactivating the interrupt circuit is achieved when data on the port is changed to the original setting or data is read from or written to the port which has generated the interrupt.

Resetting occurs as follows:

- In the Read mode at the acknowledge bit after the rising edge of the SCL signal
- In the Write mode at the acknowledge bit after the HIGH-to-LOW transition of the SCL signal
- Returning of the port data to its original setting
- Interrupts which occur during the acknowledge clock pulse may be lost (or very short) due to the resetting of the interrupt during this pulse.

Each change of the I/Os after resetting will be detected and, after the next rising clock edge, will be transmitted as \overline{INT} . Reading from or writing to another device does not affect the interrupt circuit.

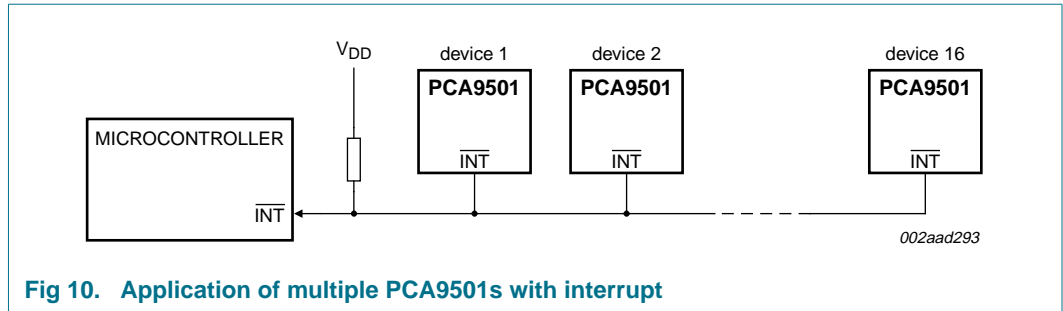

Fig 10. Application of multiple PCA9501s with interrupt

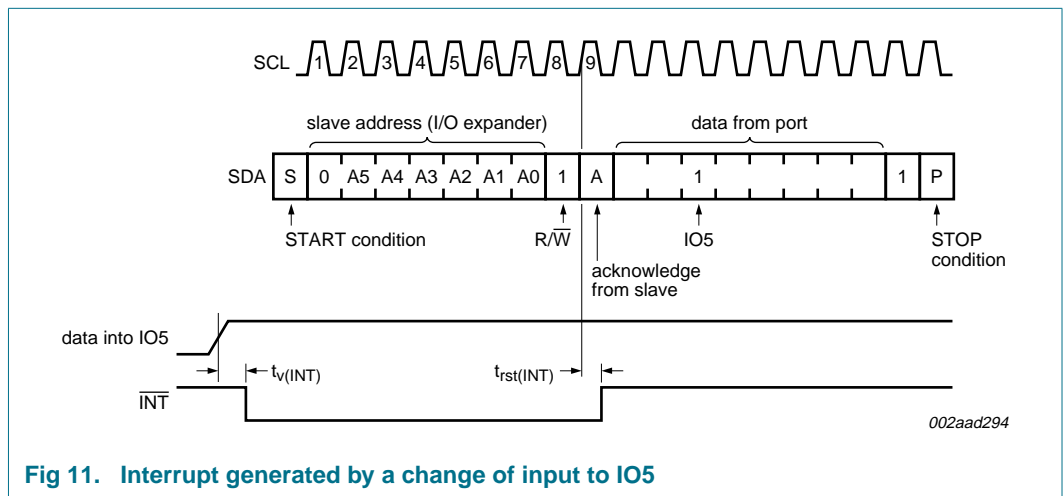

Fig 11. Interrupt generated by a change of input to IO5

7.4 Memory operations

7.4.1 Write operations

Write operations require an additional address field to indicate the memory address location to be written. The address field is eight bits long providing access to any one of the 256 words of memory. There are two types of write operations, 'byte write' and 'page write'.

Write operation is possible when the Write Control pin (\overline{WC}) is put at a LOW logic level (0). When this control signal is set at 1, write operation is not possible and data in the memory is protected.

'Byte write' and 'page write' explained below assume that \overline{WC} is set to 0.

7.4.1.1 Byte write

To perform a byte write, the START condition is followed by the memory slave address and the R/\overline{W} bit set to 0. The PCA9501 will respond with an acknowledge and then consider the next eight bits sent as the word address and the eight bits after the word address as the data. The PCA9501 will issue an acknowledge after the receipt of both the word address and the data. To terminate the data transfer the master issues the STOP condition, initiating the internal write cycle to the non-volatile memory. Only write and read operations to the quasi-bidirectional I/Os are allowed during the internal write cycle.

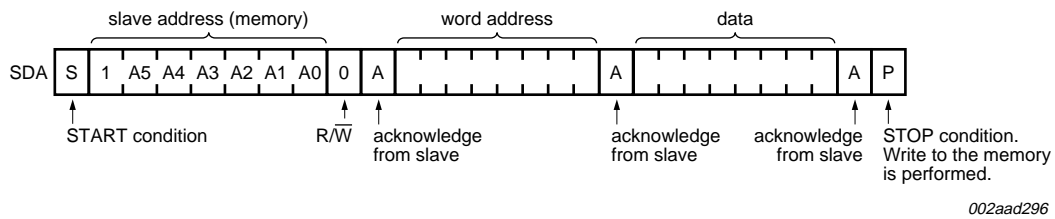

Fig 12. Byte write

7.4.1.2 Page write

A page write is initiated in the same way as the byte write, if after sending the first word of data the STOP condition is not received, the PCA9501 considers subsequent words as data. After each data word the PCA9501 responds with an acknowledge and the four least significant bits of the memory address field are incremented. Should the master not send a STOP condition after 16 data words, the address counter will return to its initial value and overwrite the data previously written. After the receipt of the STOP condition the inputs will behave as with the byte write during the internal write cycle.

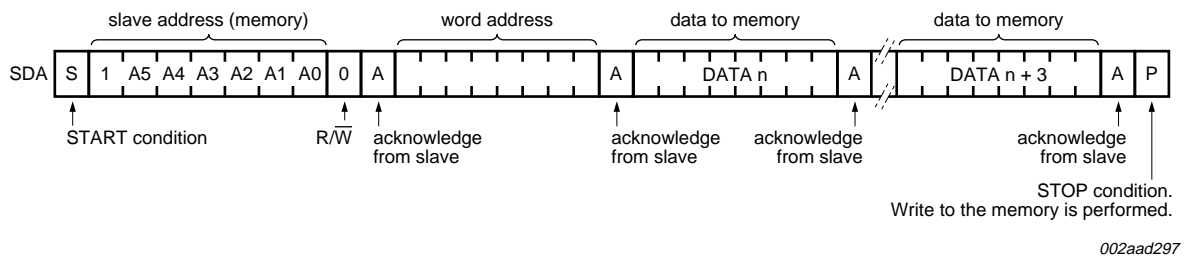

Fig 13. Page write

7.4.2 Read operations

PCA9501 read operations are initiated in an identical manner to write operations with the exception that the memory slave address R/W bit is set to '1'. There are three types of read operations: current address read, random read and sequential read.

7.4.2.1 Current address read

The PCA9501 contains an internal address counter that increments after each read or write access and as a result, if the last word accessed was at address 'n' then the address counter contains the address 'n + 1'.

When the PCA9501 receives its memory slave address with the R/W bit set to one it issues an acknowledge and uses the next eight clocks to transmit the data contained at the address stored in the address counter. The master ceases the transmission by issuing the STOP condition after the eighth bit. There is no ninth clock cycle for the acknowledge.

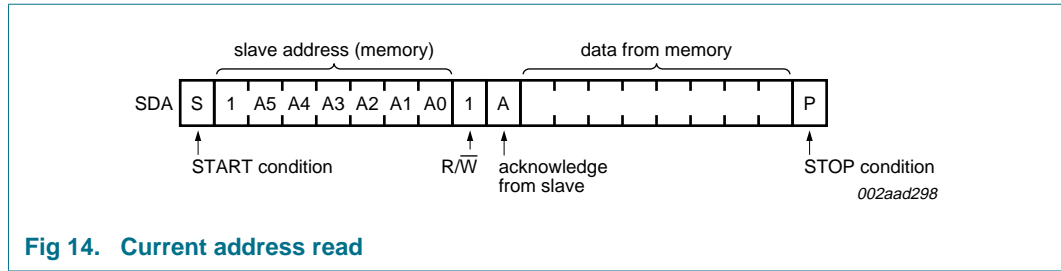

Fig 14. Current address read

7.4.2.2 Random read

The PCA9501’s random read mode allows the address to be read from to be specified by the master. This is done by performing a dummy write to set the address counter to the location to be read. The master must perform a byte write to the address location to be read, but instead of transmitting the data after receiving the acknowledge from the PCA9501, the master re-issues the START condition and memory slave address with the R/W bit set to one. The PCA9501 will then transmit an acknowledge and use the next eight clock cycles to transmit the data contained in the addressed location. The master ceases the transmission by issuing the STOP condition after the eighth bit, omitting the ninth clock cycle acknowledge.

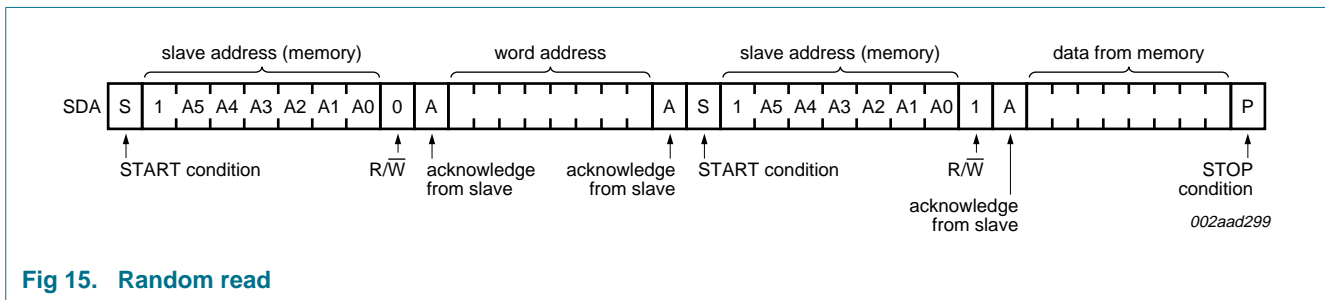

Fig 15. Random read

7.4.2.3 Sequential read

The PCA9501 sequential read is an extension of either the current address read or random read. If the master does not issue a STOP condition after it has received the eighth data bit, but instead issues an acknowledge, the PCA9501 will increment the address counter and use the next eight cycles to transmit the data from that location. The master can continue this process to read the contents of the entire memory. Upon reaching address 255 the counter will return to address 0 and continue transmitting data until a STOP condition is received. The master ceases the transmission by issuing the STOP condition after the eighth bit, omitting the ninth clock cycle acknowledge.

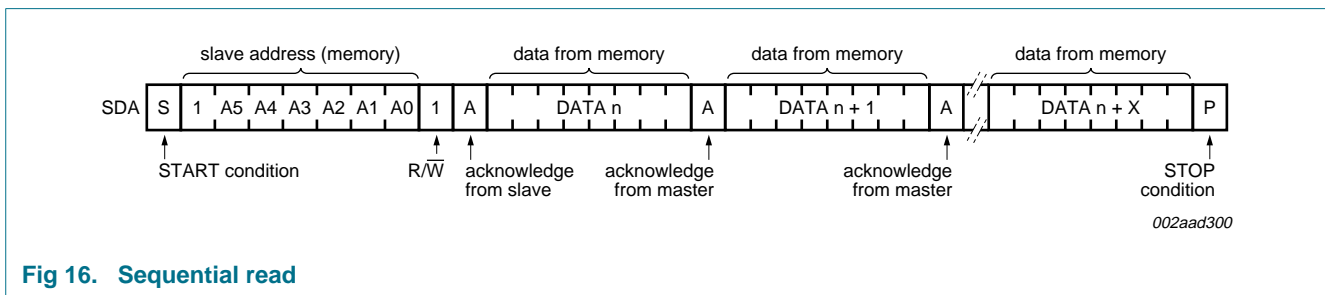

Fig 16. Sequential read

8. Characteristics of the I²C-bus

The I²C-bus is for 2-way, 2-line communication between different ICs or modules. The two lines are a serial data line (SDA) and a serial clock line (SCL). Both lines must be connected to a positive supply via a pull-up resistor when connected to the output stages of a device. Data transfer may be initiated only when the bus is not busy.

8.1 Bit transfer

One data bit is transferred during each clock pulse. The data on the SDA line must remain stable during the HIGH period of the clock pulse as changes in the data line at this time will be interpreted as control signals (see [Figure 17](#)).

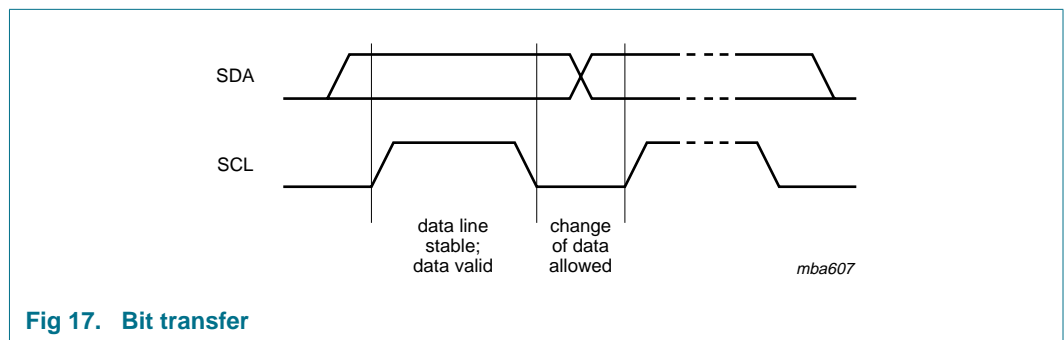

Fig 17. Bit transfer

8.1.1 START and STOP conditions

Both data and clock lines remain HIGH when the bus is not busy. A HIGH-to-LOW transition of the data line while the clock is HIGH is defined as the START condition (S). A LOW-to-HIGH transition of the data line while the clock is HIGH is defined as the STOP condition (P) (see [Figure 18](#)).

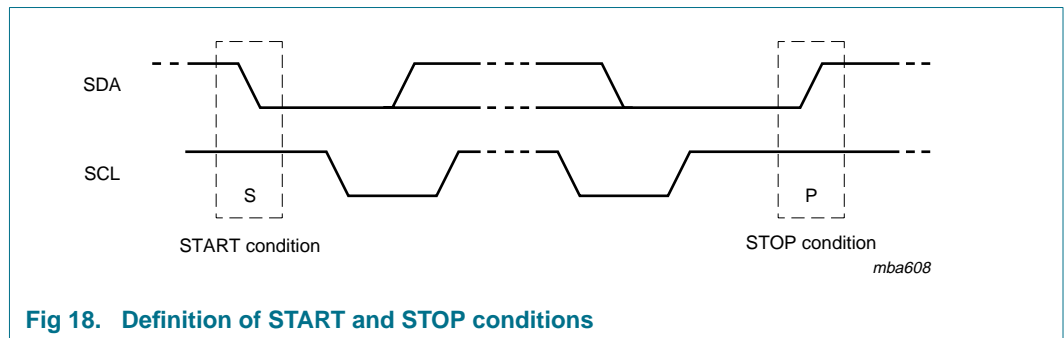

Fig 18. Definition of START and STOP conditions

8.2 System configuration

A device generating a message is a 'transmitter'; a device receiving is the 'receiver'. The device that controls the message is the 'master' and the devices which are controlled by the master are the 'slaves' (see [Figure 19](#)).

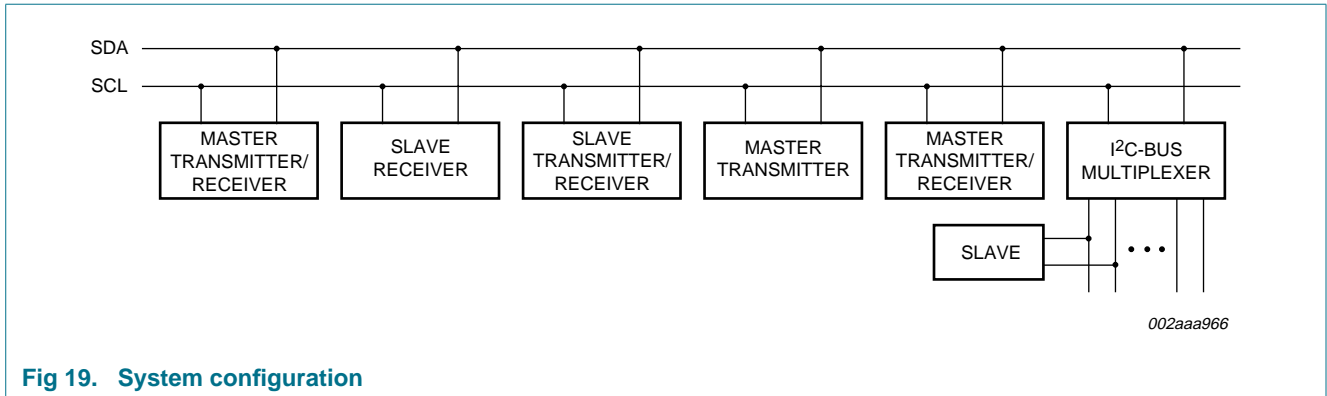

Fig 19. System configuration

8.3 Acknowledge

The number of data bytes transferred between the START and the STOP conditions from transmitter to receiver is not limited. Each byte of eight bits is followed by one acknowledge bit. The acknowledge bit is a HIGH level put on the bus by the transmitter, whereas the master generates an extra acknowledge related clock pulse.

A slave receiver which is addressed must generate an acknowledge after the reception of each byte. Also a master must generate an acknowledge after the reception of each byte that has been clocked out of the slave transmitter. The device that acknowledges has to pull down the SDA line during the acknowledge clock pulse, so that the SDA line is stable LOW during the HIGH period of the acknowledge related clock pulse; set-up and hold times must be taken into account.

A master receiver must signal an end of data to the transmitter by not generating an acknowledge on the last byte that has been clocked out of the slave. In this event, the transmitter must leave the data line HIGH to enable the master to generate a STOP condition.

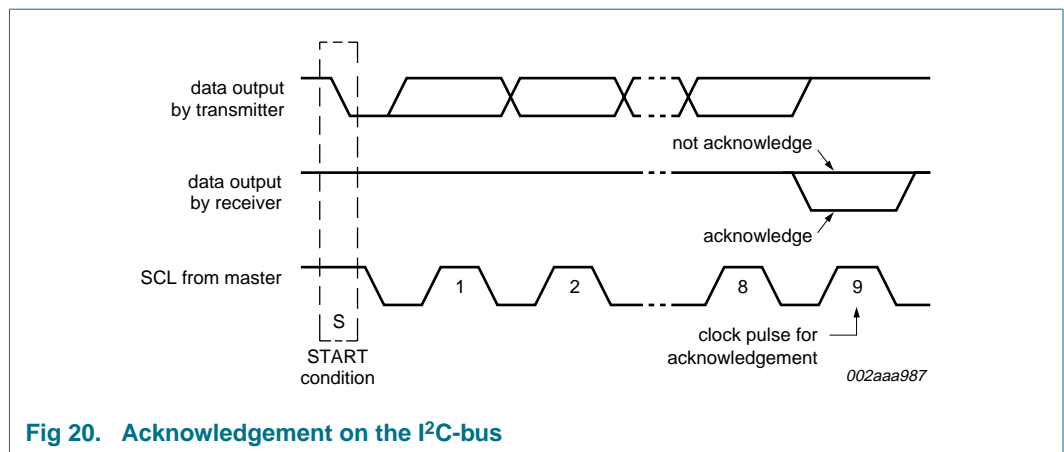

Fig 20. Acknowledgement on the I²C-bus

9. Application design-in information

A central processor/controller typically located on the system main board can use the 400 kHz I²C-bus/SMBus to poll the PCA9501 devices located on the system cards for status or version control type of information. The PCA9501 may be programmed at manufacturing to store information regarding board build, firmware version, manufacturer identification, configuration option data, and so on. Alternately, these devices can be used as convenient interface for board configuration, thereby utilizing the I²C-bus/SMBus as an intra-system communication bus

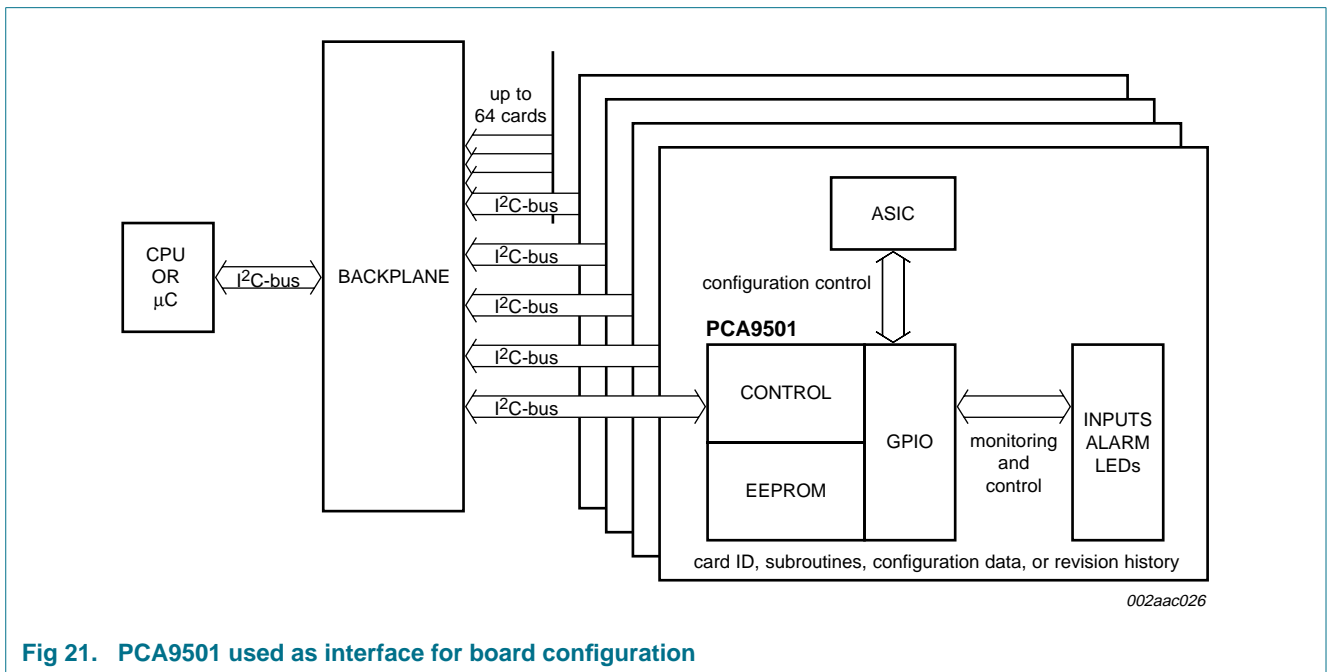

Fig 21. PCA9501 used as interface for board configuration

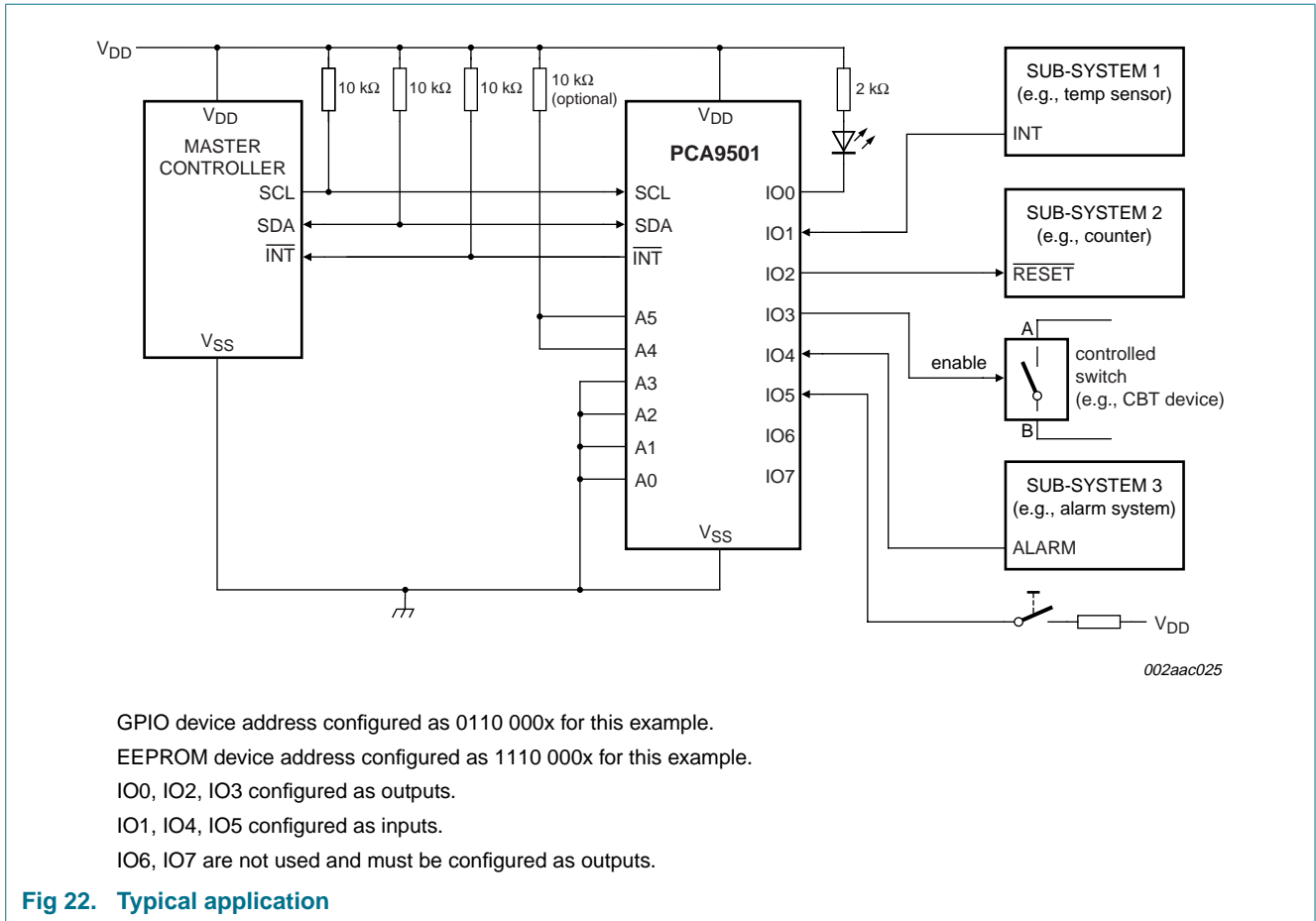

Fig 22. Typical application

10. Limiting values

Table 4. Limiting values

In accordance with the Absolute Maximum Rating System (IEC 60134).

Symbol	Parameter	Conditions	Min	Max	Unit
V _{DD}	supply voltage		-0.5	+4.0	V
V _I	input voltage		V _{SS} - 0.5	5.5	V
I _I	input current		-20	+20	mA
I _O	output current		-25	+25	mA
I _{DD}	supply current		-100	+100	mA
I _{SS}	ground supply current		-100	+100	mA
P _{tot}	total power dissipation		-	400	mW
P/out	power dissipation per output		-	100	mW
T _{stg}	storage temperature		-65	+150	°C
T _{amb}	ambient temperature	operating	-40	+85	°C

11. Static characteristics

Table 5. Static characteristics

$V_{DD} = 3.3\text{ V}$; $T_{amb} = -40\text{ °C}$ to $+85\text{ °C}$; unless otherwise specified.

Symbol	Parameter	Conditions	Min	Typ	Max	Unit
Supply						
V_{DD}	supply voltage		2.5	3.3	3.6	V
I_{DDQ}	standby current	A0 to A5; $\overline{WC} = \text{HIGH}$	-	-	60	μA
I_{DD1}	supply current read		-	-	1	mA
I_{DD2}	supply current write		-	-	2	mA
V_{POR}	power-on reset voltage		-	-	2.4	V
Input SCL; input/output SDA						
V_{IL}	LOW-level input voltage		-0.5	-	+0.3 V_{DD}	V
V_{IH}	HIGH-level input voltage		0.7 V_{DD}	-	5.5	V
I_{OL}	LOW-level output current	$V_{OL} = 0.4\text{ V}$	3	-	-	mA
I_{LI}	input leakage current	$V_I = V_{DD}$ or V_{SS}	-1	-	+1	μA
C_i	input capacitance	$V_I = V_{SS}$	-	-	7	pF
I/O expander port						
V_{IL}	LOW-level input voltage		-0.5	-	+0.3 V_{DD}	V
V_{IH}	HIGH-level input voltage		0.7 V_{DD}	-	5.5	V
$I_{IHL(max)}$	input current through protection diodes		-400	-	+400	μA
I_{OL}	LOW-level output current	$V_{OL} = 1\text{ V}$	[1] 10	25	-	mA
I_{OH}	HIGH-level output current	$V_{OH} = V_{SS}$	30	100	300	μA
I_{Oht}	transient pull-up current		-	2	-	mA
C_i	input capacitance		-	-	10	pF
C_o	output capacitance		-	-	10	pF
Address inputs A0 to A5; \overline{WC} input						
V_{IL}	LOW-level input voltage		-0.5	-	+0.3 V_{DD}	V
V_{IH}	HIGH-level input voltage		0.7 V_{DD}	-	5.5	V
I_{LI}	input leakage current	$V_I = V_{DD}$	-1	-	+1	μA
		pull-up; $V_I = V_{SS}$	10	25	100	μA
Interrupt output INT						
I_{OL}	LOW-level output current	$V_{OL} = 0.4\text{ V}$	1.6	-	-	mA
I_L	leakage current	$V_I = V_{DD}$ or V_{SS}	-1	-	+1	μA

[1] Each I/O must be externally limited to a maximum of 25 mA and the device must be limited to a maximum current of 100 mA.

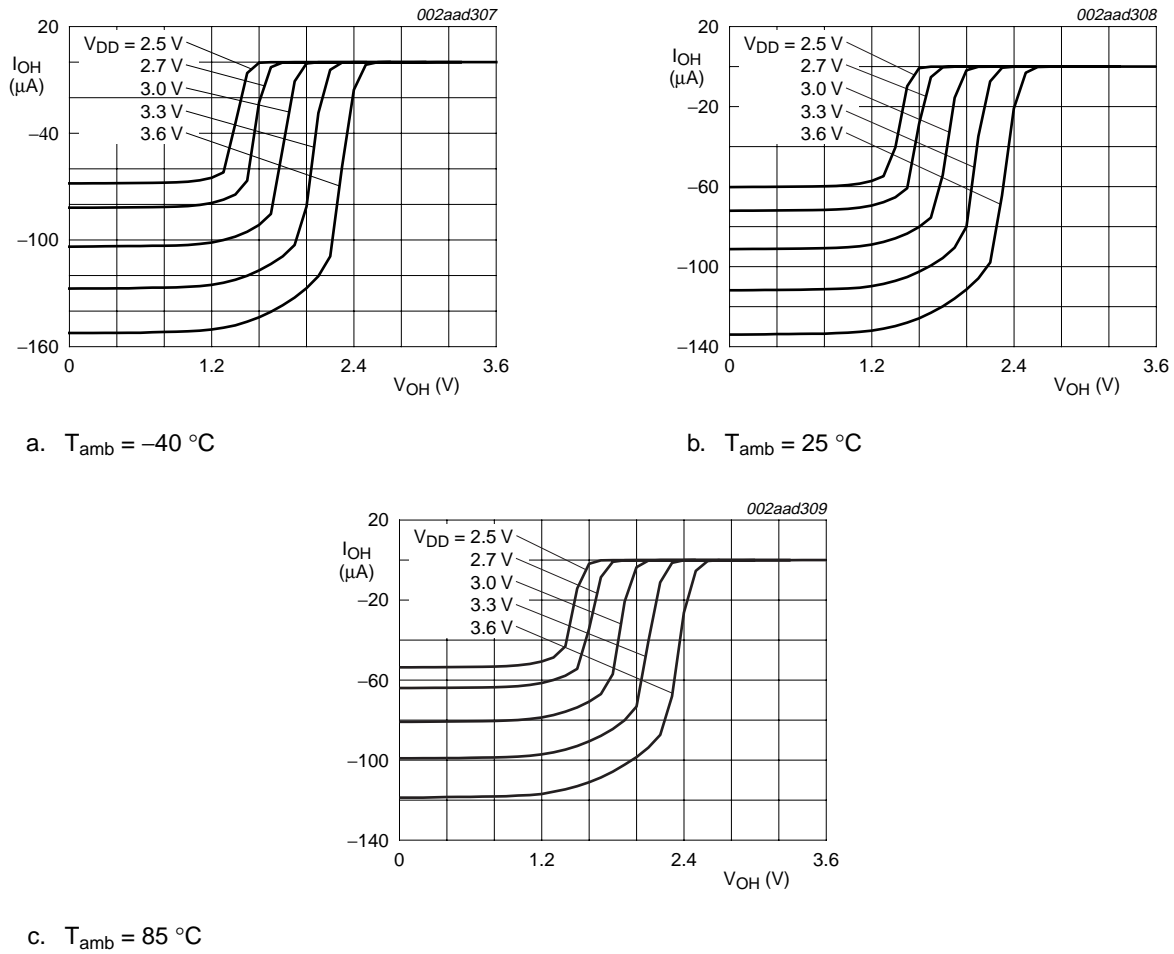

Fig 23. V_{OH} versus I_{OH}

Remark: Rapid fall-off in V_{OH} at current inception is due to a diode that provides 5 V overvoltage protection for the GPIO I/O pins. When the GPIO I/Os are being used as inputs, the internal current source V_{OH} should be evaluated to determine if external pull-up resistors are required to provide sufficient V_{IH} threshold noise margin.

12. Dynamic characteristics

Table 6. Dynamic characteristics

Symbol	Parameter	Conditions	Min	Typ	Max	Unit
I²C-bus timing ^[1] (see Figure 24)						
f _{SCL}	SCL clock frequency		-	-	400	kHz
t _{SP}	pulse width of spikes that must be suppressed by the input filter		-	-	50	ns
t _{BUF}	bus free time between a STOP and START condition		1.3	-	-	μs
t _{SU,STA}	set-up time for a repeated START condition		0.6	-	-	μs
t _{HD,STA}	hold time (repeated) START condition		0.6	-	-	μs
t _r	rise time of both SDA and SCL signals		-	-	0.3	μs
t _f	fall time of both SDA and SCL signals		-	-	0.3	μs
t _{SU,DAT}	data set-up time		250	-	-	ns
t _{HD,DAT}	data hold time		0	-	-	ns
t _{VD,DAT}	data valid time	SCL LOW to data output	-	-	1.0	μs
t _{SU,STO}	set-up time for STOP condition		0.6	-	-	μs
Port timing						
t _{v(Q)}	data output valid time	C _L ≤ 100 pF	-	-	4	μs
t _{su(D)}	data input set-up time	C _L ≤ 100 pF	0	-	-	μs
t _{h(D)}	data input hold time	C _L ≤ 100 pF	4	-	-	μs
Interrupt timing						
t _{v(INT)}	valid time on pin $\overline{\text{INT}}$	C _L ≤ 100 pF	-	-	4	μs
t _{rst(INT)}	reset time on pin $\overline{\text{INT}}$	C _L ≤ 100 pF	-	-	4	μs
Power-up timing						
t _{pu(R)}	read power-up time		[2] -	-	1	ms
t _{pu(W)}	write power-up time		[2] -	-	5	ms
Write cycle limits (see Figure 25)						
T _{cy(W)}	write cycle time		[3] -	5	10	ms

[1] All the timing values are valid within the operating supply voltage and ambient temperature range and refer to V_{IL} and V_{IH} with an input voltage swing of V_{SS} to V_{DD}.

[2] t_{pu(R)} and t_{pu(W)} are the delays required from the time V_{DD} is stable until the specified operation can be initiated. These parameters are guaranteed by design.

[3] T_{cy(W)} is the maximum time that the device requires to perform the internal write operation.

Table 7. Non-volatile storage specifications

Parameter	Specification
memory cell data retention	10 years minimum
number of memory cell write cycles	100,000 cycles minimum

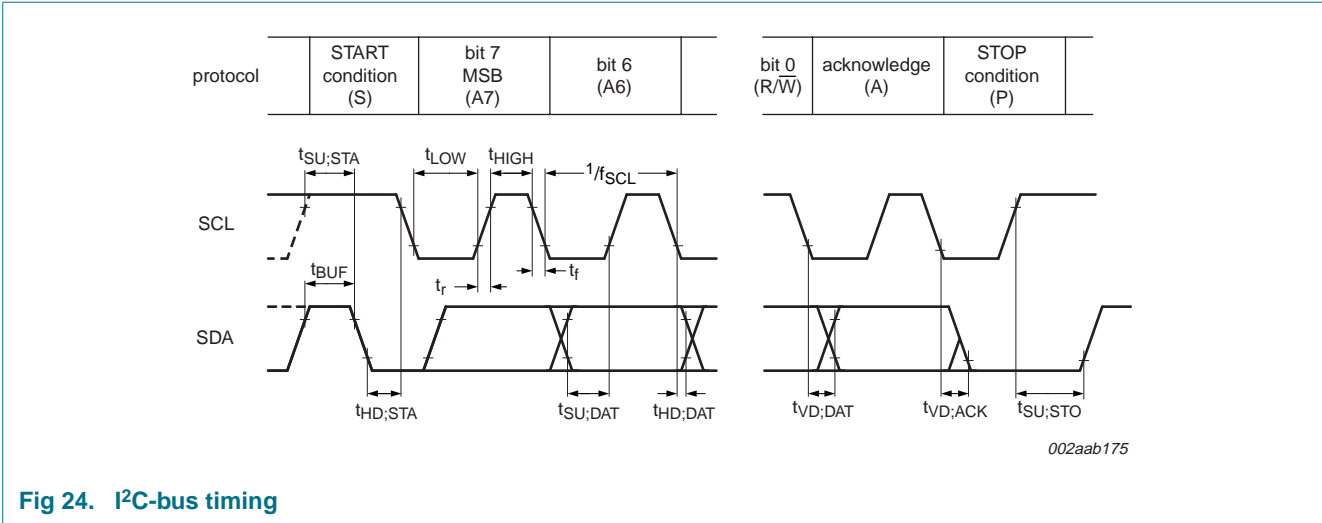

Fig 24. I²C-bus timing

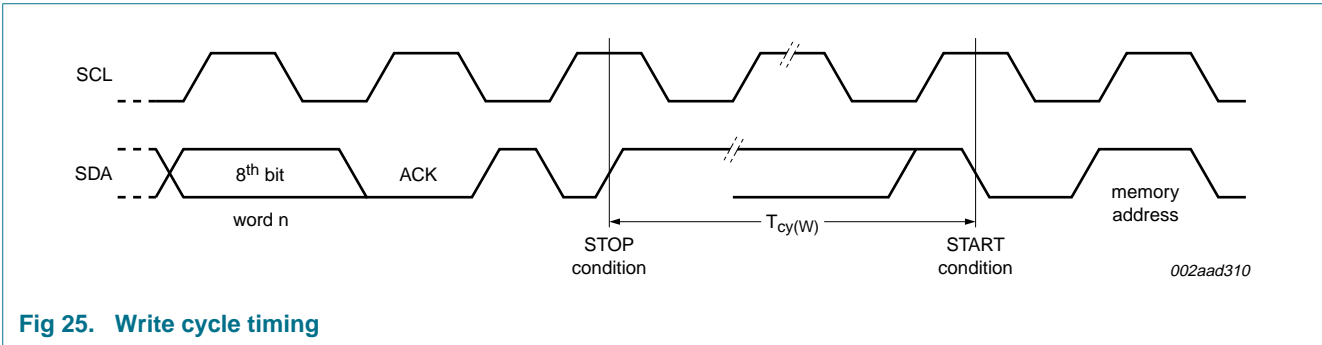

Fig 25. Write cycle timing

13. Package outline

SO20: plastic small outline package; 20 leads; body width 7.5 mm

SOT163-1

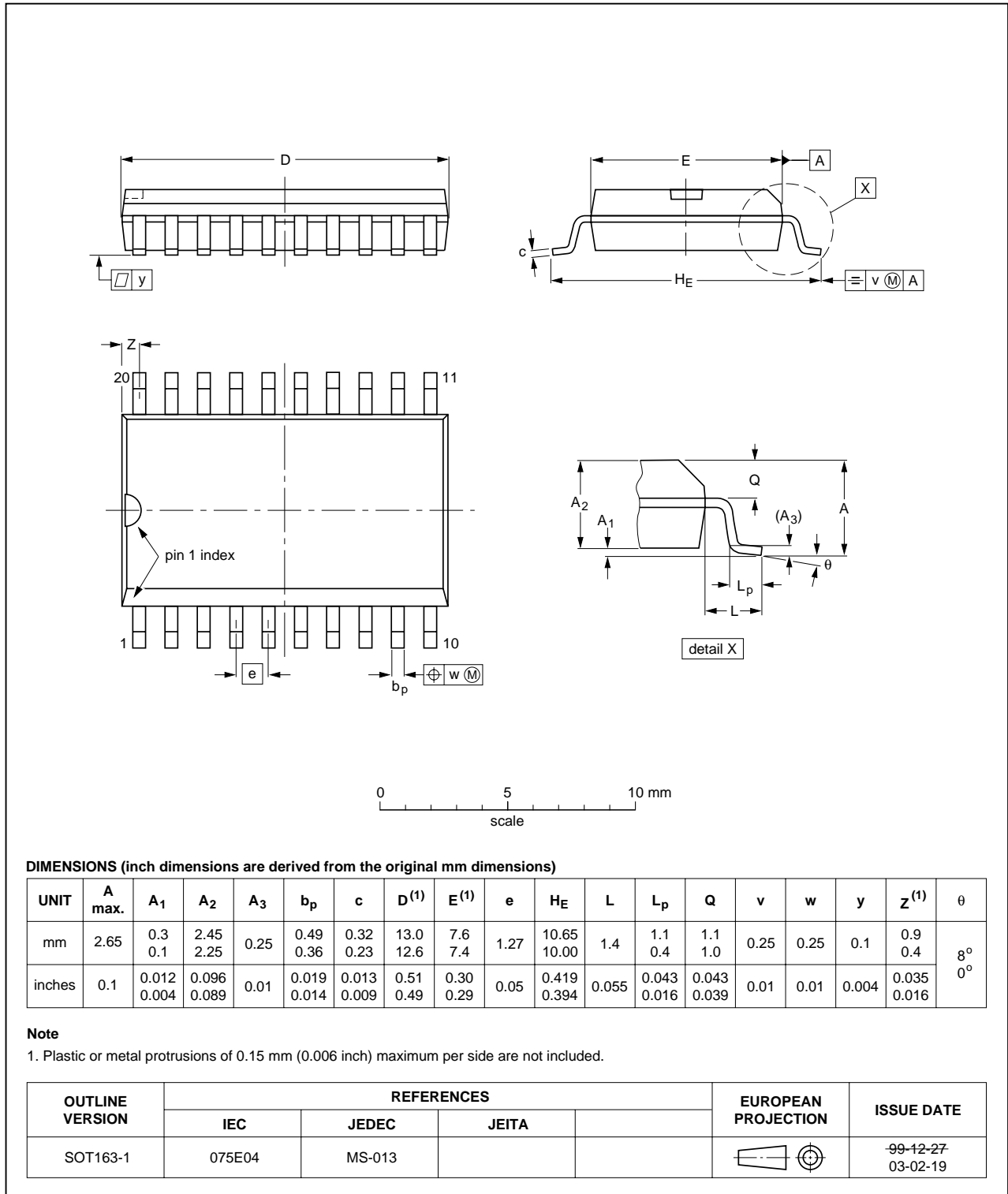

Fig 26. Package outline SOT163-1 (SO20)

TSSOP20: plastic thin shrink small outline package; 20 leads; body width 4.4 mm

SOT360-1



Fig 27. Package outline SOT360-1 (TSSOP20)

HVQFN20: plastic thermal enhanced very thin quad flat package; no leads; 20 terminals; body 5 x 5 x 0.85 mm

SOT662-1

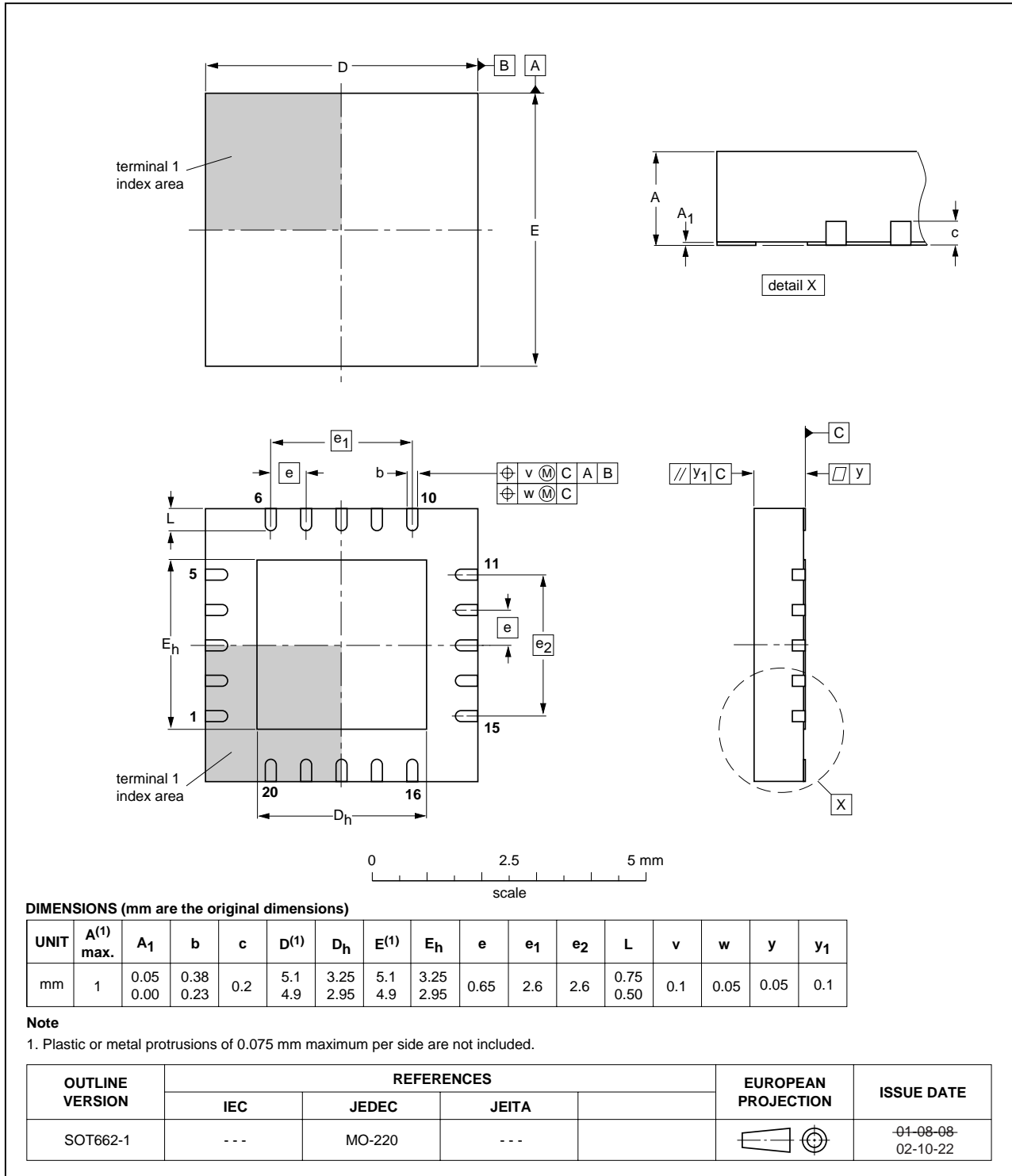

Fig 28. Package outline SOT662-1 (HVQFN20)

14. Soldering of SMD packages

This text provides a very brief insight into a complex technology. A more in-depth account of soldering ICs can be found in Application Note *AN10365 "Surface mount reflow soldering description"*.

14.1 Introduction to soldering

Soldering is one of the most common methods through which packages are attached to Printed Circuit Boards (PCBs), to form electrical circuits. The soldered joint provides both the mechanical and the electrical connection. There is no single soldering method that is ideal for all IC packages. Wave soldering is often preferred when through-hole and Surface Mount Devices (SMDs) are mixed on one printed wiring board; however, it is not suitable for fine pitch SMDs. Reflow soldering is ideal for the small pitches and high densities that come with increased miniaturization.

14.2 Wave and reflow soldering

Wave soldering is a joining technology in which the joints are made by solder coming from a standing wave of liquid solder. The wave soldering process is suitable for the following:

- Through-hole components
- Leaded or leadless SMDs, which are glued to the surface of the printed circuit board

Not all SMDs can be wave soldered. Packages with solder balls, and some leadless packages which have solder lands underneath the body, cannot be wave soldered. Also, leaded SMDs with leads having a pitch smaller than ~0.6 mm cannot be wave soldered, due to an increased probability of bridging.

The reflow soldering process involves applying solder paste to a board, followed by component placement and exposure to a temperature profile. Leaded packages, packages with solder balls, and leadless packages are all reflow solderable.

Key characteristics in both wave and reflow soldering are:

- Board specifications, including the board finish, solder masks and vias
- Package footprints, including solder thieves and orientation
- The moisture sensitivity level of the packages
- Package placement
- Inspection and repair
- Lead-free soldering versus SnPb soldering

14.3 Wave soldering

Key characteristics in wave soldering are:

- Process issues, such as application of adhesive and flux, clinching of leads, board transport, the solder wave parameters, and the time during which components are exposed to the wave
- Solder bath specifications, including temperature and impurities

14.4 Reflow soldering

Key characteristics in reflow soldering are:

- Lead-free versus SnPb soldering; note that a lead-free reflow process usually leads to higher minimum peak temperatures (see [Figure 29](#)) than a SnPb process, thus reducing the process window
- Solder paste printing issues including smearing, release, and adjusting the process window for a mix of large and small components on one board
- Reflow temperature profile; this profile includes preheat, reflow (in which the board is heated to the peak temperature) and cooling down. It is imperative that the peak temperature is high enough for the solder to make reliable solder joints (a solder paste characteristic). In addition, the peak temperature must be low enough that the packages and/or boards are not damaged. The peak temperature of the package depends on package thickness and volume and is classified in accordance with [Table 8](#) and [9](#)

Table 8. SnPb eutectic process (from J-STD-020C)

Package thickness (mm)	Package reflow temperature (°C)	
	Volume (mm ³)	
	< 350	≥ 350
< 2.5	235	220
≥ 2.5	220	220

Table 9. Lead-free process (from J-STD-020C)

Package thickness (mm)	Package reflow temperature (°C)		
	Volume (mm ³)		
	< 350	350 to 2000	> 2000
< 1.6	260	260	260
1.6 to 2.5	260	250	245
> 2.5	250	245	245

Moisture sensitivity precautions, as indicated on the packing, must be respected at all times.

Studies have shown that small packages reach higher temperatures during reflow soldering, see [Figure 29](#).

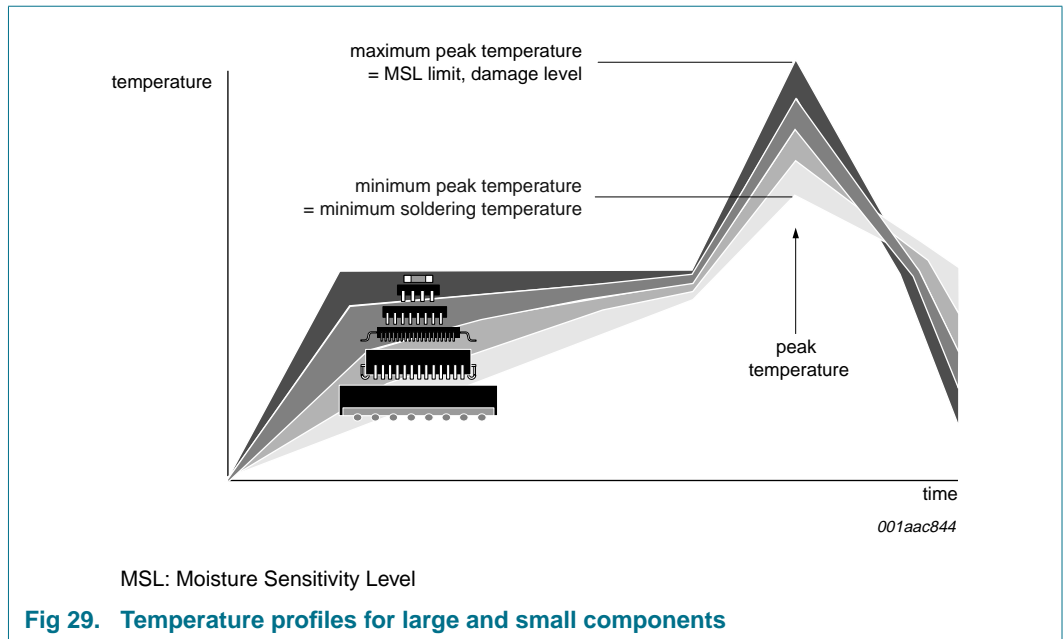

For further information on temperature profiles, refer to Application Note AN10365 “Surface mount reflow soldering description”.

15. Abbreviations

Table 10. Abbreviations

Acronym	Description
ASIC	Application Specific Integrated Circuit
CBT	Cross Bar Technology
CDM	Charged-Device Model
CPU	Central Processing Unit
EEPROM	Electrically Erasable Programmable Read Only Memory
ESD	ElectroStatic Discharge
GPIO	General Purpose Input/Output
HBM	Human Body Model
I ² C-bus	Inter Integrated Circuit bus
I/O	Input/Output
IC	Integrated Circuit
LED	Light Emitting Diode
LP	Low-Pass
μC	micro Controller
MM	Machine Model
SMBus	System Management Bus

16. Revision history

Table 11. Revision history

Document ID	Release date	Data sheet status	Change notice	Supersedes
PCA9501_4	20090210	Product data sheet	-	PCA9501_3

Modifications:

- The format of this data sheet has been redesigned to comply with the new identity guidelines of NXP Semiconductors.
- Legal texts have been adapted to the new company name where appropriate.
- [Section 1 “General description”](#), 5th paragraph, 2nd sentence changed from “The fixed GPIO address starts with ‘1’ and the fixed EEPROM I²C address starts with ‘0’, ...” to “The fixed GPIO address starts with ‘0’ and the fixed EEPROM I²C-bus address starts with ‘1’, ...”
- [Table 3 “Pin description”](#):
 - pin “WC” corrected to “ \overline{WC} ”
 - added [Table note 1](#) and its reference at HVQFN20 pin 8
 - changed naming convention for pins I/On to “IOn”
- [Section 7.1 “Device addressing”](#): added Remark and bulleted list (4 items)
- [Figure 7 “I/O Write mode \(output\)”](#): changed symbol “t_{pv}” to “t_{v(Q)}”
- [Figure 8 “I/O Read mode \(input\)”](#):
 - changed symbol “t_{ph}” to “t_{h(D)}”
 - changed symbol “t_{ps}” to “t_{su(D)}”
 - changed symbol “t_{iv}” to “t_{v(INT)}”
 - changed symbol “t_{ir}” to “t_{rst(INT)}”
- [Section 7.3.2 “Interrupt”](#), 2nd paragraph: changed symbol “t_{iv}” to “t_{v(INT)}”
- [Figure 11 “Interrupt generated by a change of input to IO5”](#):
 - changed symbol “t_{iv}” to “t_{v(INT)}”
 - changed symbol “t_{ir}” to “t_{rst(INT)}”
- [Table 4 “Limiting values”](#):
 - changed symbol “V_{CC}” to “V_{DD}”
 - changed parameter for I_{SS} from “supply current” to “ground supply current”
 - changed symbol “P_O” to “P/out”
- [Table 5 “Static characteristics”](#):
 - sub-section “Input SCL; input/output SDA”: changed symbol “I_L” to “I_L”
 - sub-section “Address inputs A0 to A5; \overline{WC} input”: changed symbol “I_L” to “I_L”
 - added reference to [Table note 1](#) at I_{OL} in sub-section “I/O expander port”
- [Table 6 “Dynamic characteristics”](#):
 - sub-section “I²C-bus timing”: changed symbol/parameter from “t_{SW}, tolerable spike width on bus” to “t_{SP}, pulse width of spikes that must be suppressed by the input filter”
 - sub-section “Port timing”: changed symbol “t_{pv}” to “t_{v(Q)}”
 - sub-section “Port timing”: changed symbol “t_{ph}” to “t_{h(D)}”
 - sub-section “Port timing”: changed symbol “t_{ps}” to “t_{su(D)}”
 - sub-section “Interrupt timing”: changed symbol “t_{iv}” to “t_{v(INT)}”
 - sub-section “Interrupt timing”: changed symbol “t_{ir}” to “t_{rst(INT)}”
 - sub-section “Power-up timing”: changed symbol “t_{PUR}” to “t_{pu(R)}”
 - sub-section “Power-up timing”: changed symbol “t_{PUW}” to “t_{pu(W)}”
 - sub-section “Write cycle limits”: changed symbol “t_{WR}” to “T_{cy(W)}”

Table 11. Revision history ...continued

Document ID	Release date	Data sheet status	Change notice	Supersedes
Modifications: (continued)	<ul style="list-style-type: none">• added Section 15 “Abbreviations”• updated soldering information			
PCA9501_3 (9397 750 14135)	20040930	Product data	-	PCA9501_2
PCA9501_2 (9397 750 12058)	20030912	Product data	853-2370 30128 of 2003 Jul 18	PCA9501_1
PCA9501_1 (9397 750 10327)	20020927	Product data	853-2370 28875 of 2002 Sep 09	-

17. Legal information

17.1 Data sheet status

Document status ^{[1][2]}	Product status ^[3]	Definition
Objective [short] data sheet	Development	This document contains data from the objective specification for product development.
Preliminary [short] data sheet	Qualification	This document contains data from the preliminary specification.
Product [short] data sheet	Production	This document contains the product specification.

[1] Please consult the most recently issued document before initiating or completing a design.

[2] The term 'short data sheet' is explained in section "Definitions".

[3] The product status of device(s) described in this document may have changed since this document was published and may differ in case of multiple devices. The latest product status information is available on the Internet at URL <http://www.nxp.com>.

17.2 Definitions

Draft — The document is a draft version only. The content is still under internal review and subject to formal approval, which may result in modifications or additions. NXP Semiconductors does not give any representations or warranties as to the accuracy or completeness of information included herein and shall have no liability for the consequences of use of such information.

Short data sheet — A short data sheet is an extract from a full data sheet with the same product type number(s) and title. A short data sheet is intended for quick reference only and should not be relied upon to contain detailed and full information. For detailed and full information see the relevant full data sheet, which is available on request via the local NXP Semiconductors sales office. In case of any inconsistency or conflict with the short data sheet, the full data sheet shall prevail.

17.3 Disclaimers

General — Information in this document is believed to be accurate and reliable. However, NXP Semiconductors does not give any representations or warranties, expressed or implied, as to the accuracy or completeness of such information and shall have no liability for the consequences of use of such information.

Right to make changes — NXP Semiconductors reserves the right to make changes to information published in this document, including without limitation specifications and product descriptions, at any time and without notice. This document supersedes and replaces all information supplied prior to the publication hereof.

Suitability for use — NXP Semiconductors products are not designed, authorized or warranted to be suitable for use in medical, military, aircraft, space or life support equipment, nor in applications where failure or malfunction of an NXP Semiconductors product can reasonably be expected

to result in personal injury, death or severe property or environmental damage. NXP Semiconductors accepts no liability for inclusion and/or use of NXP Semiconductors products in such equipment or applications and therefore such inclusion and/or use is at the customer's own risk.

Applications — Applications that are described herein for any of these products are for illustrative purposes only. NXP Semiconductors makes no representation or warranty that such applications will be suitable for the specified use without further testing or modification.

Limiting values — Stress above one or more limiting values (as defined in the Absolute Maximum Ratings System of IEC 60134) may cause permanent damage to the device. Limiting values are stress ratings only and operation of the device at these or any other conditions above those given in the Characteristics sections of this document is not implied. Exposure to limiting values for extended periods may affect device reliability.

Terms and conditions of sale — NXP Semiconductors products are sold subject to the general terms and conditions of commercial sale, as published at <http://www.nxp.com/profile/terms>, including those pertaining to warranty, intellectual property rights infringement and limitation of liability, unless explicitly otherwise agreed to in writing by NXP Semiconductors. In case of any inconsistency or conflict between information in this document and such terms and conditions, the latter will prevail.

No offer to sell or license — Nothing in this document may be interpreted or construed as an offer to sell products that is open for acceptance or the grant, conveyance or implication of any license under any copyrights, patents or other industrial or intellectual property rights.

17.4 Trademarks

Notice: All referenced brands, product names, service names and trademarks are the property of their respective owners.

I²C-bus — logo is a trademark of NXP B.V.

18. Contact information

For more information, please visit: <http://www.nxp.com>

For sales office addresses, please send an email to: salesaddresses@nxp.com

19. Contents

1	General description	1	18	Contact information	27
2	Features	1	19	Contents	28
3	Applications	2			
4	Ordering information	2			
4.1	Ordering options	2			
5	Block diagram	3			
6	Pinning information	3			
6.1	Pinning	3			
6.2	Pin description	4			
7	Functional description	5			
7.1	Device addressing	5			
7.2	Control register	6			
7.3	I/O operations	6			
7.3.1	Quasi-bidirectional I/Os	7			
7.3.2	Interrupt	7			
7.4	Memory operations	8			
7.4.1	Write operations	8			
7.4.1.1	Byte write	8			
7.4.1.2	Page write	9			
7.4.2	Read operations	9			
7.4.2.1	Current address read	9			
7.4.2.2	Random read	10			
7.4.2.3	Sequential read	10			
8	Characteristics of the I²C-bus	11			
8.1	Bit transfer	11			
8.1.1	START and STOP conditions	11			
8.2	System configuration	11			
8.3	Acknowledge	12			
9	Application design-in information	13			
10	Limiting values	14			
11	Static characteristics	15			
12	Dynamic characteristics	17			
13	Package outline	19			
14	Soldering of SMD packages	22			
14.1	Introduction to soldering	22			
14.2	Wave and reflow soldering	22			
14.3	Wave soldering	22			
14.4	Reflow soldering	23			
15	Abbreviations	24			
16	Revision history	25			
17	Legal information	27			
17.1	Data sheet status	27			
17.2	Definitions	27			
17.3	Disclaimers	27			
17.4	Trademarks	27			

Please be aware that important notices concerning this document and the product(s) described herein, have been included in section 'Legal information'.



© NXP B.V. 2009.

All rights reserved.

For more information, please visit: <http://www.nxp.com>
 For sales office addresses, please send an email to: salesaddresses@nxp.com

Date of release: 10 February 2009
 Document identifier: PCA9501_4