

300mA Ultra-low Power Buck Boost DC/DC Converter with Battery Monitor

No. EA-516-200226

OVERVIEW

RP605x is an ultra-low power DC/DC converter with a Battery Monitor (BM). The battery monitor divides the input voltage (V_{IN}) into 1/3 or 1/4 and directly provides the buffered voltage to a low-voltage AD converter in MCU, it monitors the remaining quantity of the battery.

KEY BENEFITS

- Long-time operation of battery powered equipment and downsizing of battery due to the ultra-low consumption current ($I_Q = 0.3 \mu A$).
- Reducing components and saving space by combining DC/DC and BM into a single chip.
- Suitable for coin batteries and USB ports due to its wide input voltage range from 1.8 V to 5.5 V

KEY SPECIFICATIONS

DC/DC Section

- Supply Current: Typ. $0.3 \mu A$
- Output Current: 300 mA
- Input Voltage Range: 1.8 V to 5.5 V
- Output Voltage Range: 1.6 V to 5.2 V
- Output Voltage Accuracy: $\pm 1.5\%$

Battery Monitor Section

- Output Voltage: $V_{IN}/3$ (RP605xxx3x)
 $V_{IN}/4$ (RP605xxx4x)
- Supply Current: Typ. $0.1 \mu A$

PACKAGES (unit: mm)

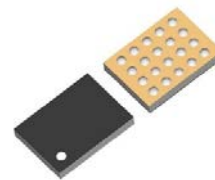

WLCSP-20-P3
2.315 x 1.71 x 0.36

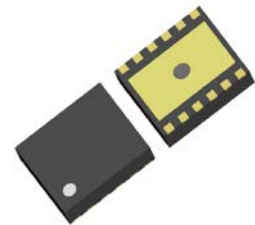

DFN(PLP)2730-12
3.00 x 2.70 x 0.6

TYPICAL APPLICATIONS

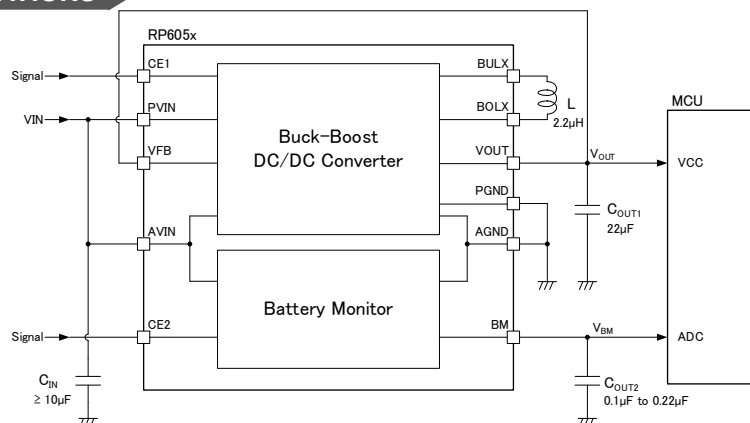

APPLICATIONS

- Devices with Coin Cell Battery and Lithium Ion Battery
- Wearable devices including Smart watch, Smart band, and Health monitor
- Low power RF Modules including: *Bluetooth*® LE, Zigbee, WiSun and ANT
- Low power CPUs, Memory, Sensor device and Energy harvester

RP605x

No. EA-516-200226

SELECTION GUIDE

The DC/DC set output voltage, the division ratio of BM output, the DC/DC auto-discharge function ⁽¹⁾, and the package are user-selectable options.

Selection Guide

Product Name	Package	Quantity per Reel	Pb Free	Halogen Free
RP605Zxx#-\$-E2-F	WLCSP-20-P3	5,000 pcs	Yes	Yes
RP605Kxx#-\$-TR	DFN(PLP)2730-12	5,000 pcs	Yes	Yes

xx: Specify the DC/DC set output voltage (V_{SET})

Fixed output voltage type: 1.6 V (16) to 5.2 V (52) in 0.1 V step

Refer to the *Product-specific Electrical Characteristics* for detail information

#: Specify the division ratio of BM output

3 : $V_{IN}/3$

4 : $V_{IN}/4$

\$: Specify the DC/DC auto-discharge option.

A: DC/DC auto-discharge is not included

B: DC/DC auto-discharge is included

⁽¹⁾Auto-discharge function quickly lowers the output voltage to 0 V by releasing the electrical charge accumulated in the external capacitor when the chip enable signal is switched from the active mode to the standby mode.

BLOCK DIAGRAMS

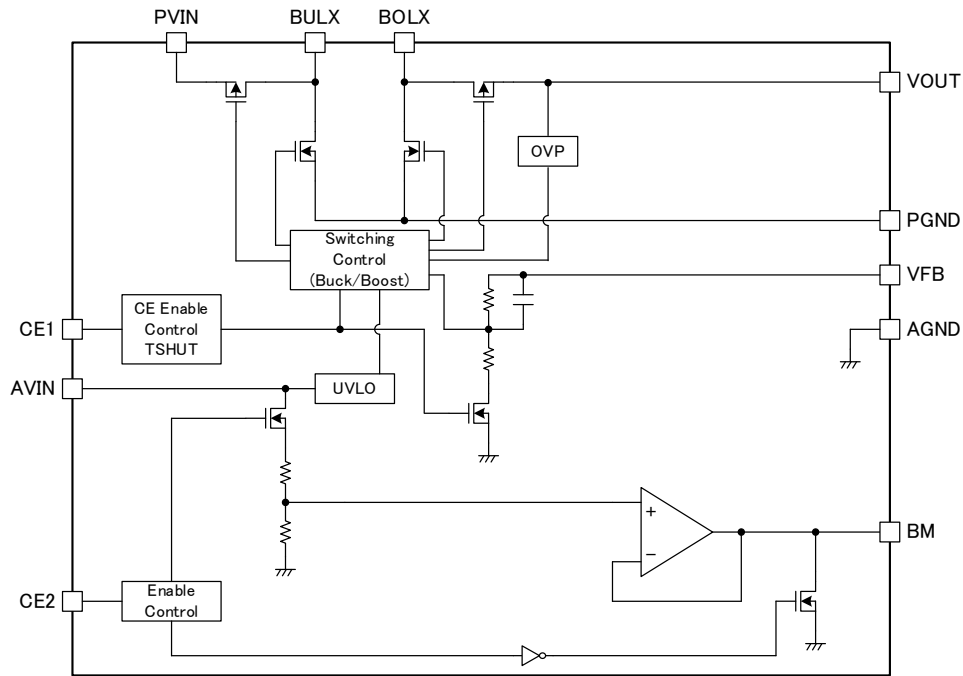

RP605xxxxA Block Diagram: DC/DC auto-discharge is not included

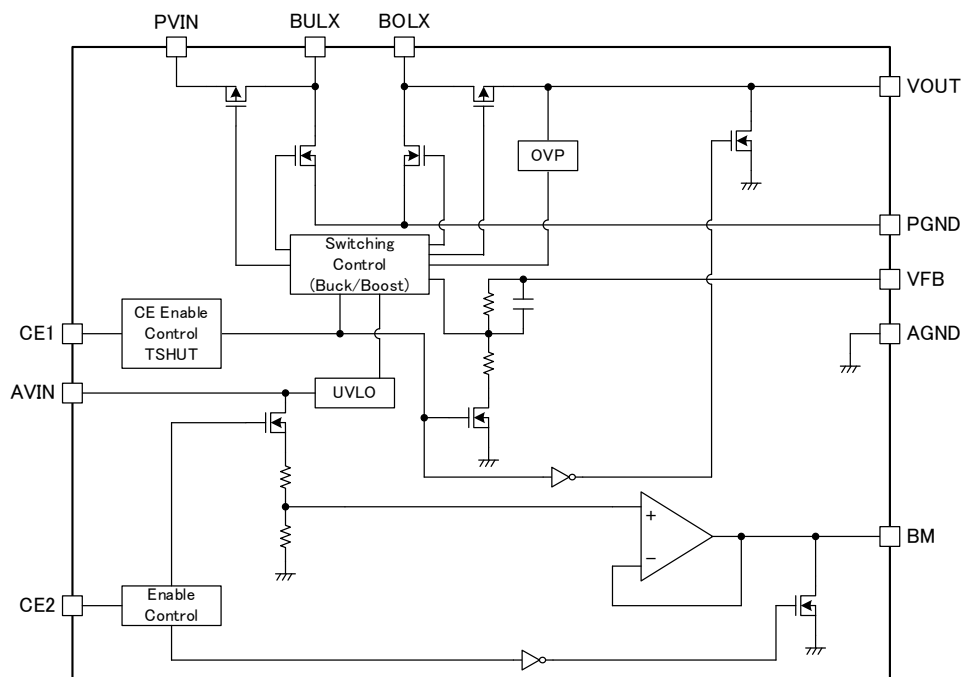

RP605xxxxB Block Diagram: DC/DC auto-discharge is included

RP605x

No. EA-516-200226

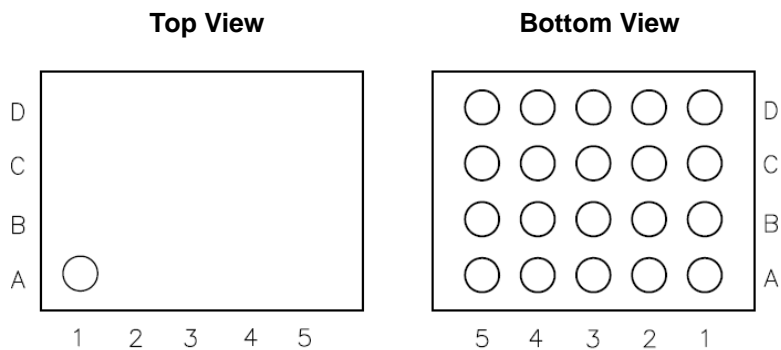
PIN DESCRIPTIONS**RP605Z Pin Description**

Pin No.	Symbol	Description
A5, B5	VOUT	DC/DC Output Pin
A4, B4, C4	BOLX	Boost Switching Output LX Pin
A3, B3, C3	PGND	Power Ground Pin
A2, B2, C2	BULX	Buck Switching Output LX Pin
A1, B1, C1	PVIN	Power Source Input Pin
C5	VFB	Feedback Pin
D1	AVIN	Analog Power Supply Pin
D2	CE1	DC/DC Enable Pin (Active-high)
D3	AGND	Analog Ground Pin
D4	CE2	Battery Monitor Enable Pin (Active-high)
D5	BM	Battery Monitor Output Pin



RP605K [DFN(PLP)2730-12] Pin Configuration

RP605K Pin Description

Pin No.	Symbol	Description
1	AVIN	Analog Power Supply Pin
2	CE1	DC/DC Enable Pin (Active-high)
3	AGND	Analog Ground Pin
4	CE2	Battery Monitor Enable Pin (Active-high)
5	BM	Battery Monitor Output Pin
6	VFB	Feedback Pin
7	VOUT	DC/DC Output Pin
8	BOLX	Boost Switching Output LX Pin
9	PGND	Power Ground Pin
10	PGND	Power Ground Pin
11	BULX	Buck Switching Output LX Pin
12	PVIN	Power Source Input Pin

* The tab on the bottom of the package shown by blue circle is a substrate potential (GND). It is recommended that this tab be connected to the ground plane on the board, but it is possible to leave the tab floating.

RP605x

No. EA-516-200226

ABSOLUTE MAXIMUM RATINGS

Absolute Maximum Ratings

Symbol	Item	Rating	Unit
V_{IN}	Input Voltage	-0.3 to 6.5	V
V_{BULX}	BULX Pin Voltage	-0.3 to $V_{IN} + 0.3$	V
V_{BOLX}	BOLX Pin Voltage	-0.3 to $V_{OUT} + 0.3$	V
V_{CE1}	CE1 Pin Voltage	-0.3 to 6.5	V
V_{CE2}	CE2 Pin Voltage	-0.3 to 6.5	V
V_{OUT}	VOUT Pin Voltage	-0.3 to 6.5	V
V_{FB}	VFB Pin Voltage	-0.3 to 6.5	V
V_{BM}	BM Pin Voltage	-0.3 to $V_{IN} + 0.3$	V
P_D	Power Dissipation	Refer to Appendix "POWER DISSIPATION"	
T_j	Junction Temperature Range	-40 to 125	°C
T_{stg}	Storage Temperature Range	-55 to 125	°C

ABSOLUTE MAXIMUM RATINGS

Electronic and mechanical stress momentarily exceeded absolute maximum ratings may cause permanent damage and may degrade the life time and safety for both device and system using the device in the field. The functional operation at or over these absolute maximum ratings is not assured.

RECOMMENDED OPERATING CONDITIONS

Recommended Operating Conditions

Symbol	Item		Rating	Unit
V_{IN}	Input Voltage	RP605xxx3x	1.8 to 5.5	V
		RP605xxx4x	2.4 to 5.5	
T_a	Operating Temperature		-40 to 85	°C

RECOMMENDED OPERATING CONDITIONS

All of electronic equipment should be designed that the mounted semiconductor devices operate within the recommended operating conditions. The semiconductor devices cannot operate normally over the recommended operating conditions, even if they are used over such conditions by momentary electronic noise or surge. And the semiconductor devices may receive serious damage when they continue to operate over the recommended operating conditions.

ELECTRICAL CHARACTERISTICS

The specifications surrounded by are guaranteed by design engineering at $-40^{\circ}\text{C} \leq T_a \leq 85^{\circ}\text{C}$.

RP605x Electrical Characteristics: DC/DC Section

($T_a = 25^{\circ}\text{C}$)

Symbol	Parameter	Conditions	Min.	Typ.	Max.	Unit
V_{OUT}	Output voltage	$V_{\text{IN}} = V_{\text{CE1}} = 3.6 \text{ V}$	x 0.985		x 1.015	V
I_{Q}	Operating quiescent current	$V_{\text{IN}} = V_{\text{CE1}} = V_{\text{OUT}} = 3.6 \text{ V}$, $V_{\text{SET}} = 3.3\text{V}$, at rest		0.3		μA
I_{STANDBY}	Standby current	$V_{\text{IN}} = 5.5 \text{ V}$, $V_{\text{CE1}} = 0 \text{ V}$		0.01	1	μA
I_{CE1H}	CE1 pin input current, high	$V_{\text{IN}} = V_{\text{CE1}} = 5.5 \text{ V}$	-0.025	0	0.025	μA
I_{CE1L}	CE1 pin input current, low	$V_{\text{IN}} = 5.5 \text{ V}$, $V_{\text{CE1}} = 0 \text{ V}$	-0.025	0	0.025	μA
I_{VFBH}	VFB pin input current, high	$V_{\text{IN}} = V_{\text{FB}} = 5.5 \text{ V}$, $V_{\text{CE1}} = 0 \text{ V}$	-0.025	0	0.025	μA
$I_{\text{VFB L}}$	VFB pin input current, low	$V_{\text{IN}} = 5.5 \text{ V}$, $V_{\text{CE1}} = V_{\text{FB}} = 0 \text{ V}$	-0.025	0	0.025	μA
V_{OVP}	Overvoltage Protection (OVP) Threshold	$V_{\text{IN}} = 3.6 \text{ V}$, Rising (Detection)		6.0		V
		$V_{\text{IN}} = 3.6 \text{ V}$, Falling (Release)		5.5		V
R_{DISN}	Auto-discharge NMOS on-resistance	$V_{\text{IN}} = 3.6 \text{ V}$, $V_{\text{CE1}} = 0 \text{ V}$ RP605xxxxB only		100		Ω
V_{CE1H}	CE1 pin input voltage, high	$V_{\text{IN}} = 5.5 \text{ V}$	1.0			V
V_{CE1L}	CE1 pin input voltage, low	$V_{\text{IN}} = 1.8 \text{ V}$			0.4	V
R_{ONP}	PMOS on-resistance	RP605Z $V_{\text{IN}} = 3.6 \text{ V}$, $I_{\text{LX}} = -100 \text{ mA}$		0.12		Ω
		RP605K $V_{\text{IN}} = 3.6 \text{ V}$, $I_{\text{LX}} = -100 \text{ mA}$		0.15		Ω
R_{ONN}	NMOS on-resistance	RP605Z $V_{\text{IN}} = 3.6 \text{ V}$, $I_{\text{LX}} = -100 \text{ mA}$		0.12		Ω
		RP605K $V_{\text{IN}} = 3.6 \text{ V}$, $I_{\text{LX}} = -100 \text{ mA}$		0.15		Ω
T_{TSD}	Thermal Shutdown Threshold Temperature	T_{j} , Rising (Detection)		140		$^{\circ}\text{C}$
T_{TSR}		T_{j} , Falling (Release)		100		$^{\circ}\text{C}$
t_{START}	Soft-start time	$V_{\text{IN}} = V_{\text{CE1}} = 3.6 \text{ V}$		20		ms
I_{LXLIM}	BULX Limiting current	$V_{\text{IN}} = V_{\text{CE1}} = 3.6 \text{ V}$	600	900		mA
V_{UVLOF}	Undervoltage Lockout (UVLO) Threshold	$V_{\text{IN}} = V_{\text{CE1}}$, Falling (Detection)	1.40	1.50	1.65	V
V_{UVLOR}		$V_{\text{IN}} = V_{\text{CE1}}$, Rising (Release)	1.55	1.65	1.80	V

All test items listed under Electrical Characteristics are done under the pulse load condition ($T_{\text{j}} \approx T_a = 25^{\circ}\text{C}$).

Test circuit is operated under condition of "Open Loop Control" ($\text{GND} = 0 \text{ V}$), unless otherwise specified.

RP605x

No. EA-516-200226

ELECTRICAL CHARACTERISTICS (Continued)The specifications surrounded by are guaranteed by design engineering at $-40^{\circ}\text{C} \leq T_a \leq 85^{\circ}\text{C}$.**RP605x Electrical Characteristics: Battery Monitor Section**

(Ta = 25°C)

Symbol	Parameter	Conditions	Min.	Typ.	Max.	Unit	
V _{BM}	Output voltage	V _{IN} = 3.6 V, -10μA ≤ I _{BM} ≤ 10μA	RP605xxx3x	V _{IN} /3-30	V _{IN} /3	V _{IN} /3+30	mV
			RP605xxx4x	V _{IN} /4-30	V _{IN} /4	V _{IN} /4+30	
I _{BM}	Output current	V _{IN} = 3.6 V	-10		10	μA	
I _{SSBM}	Supply current	I _{BM} = 0 μA		0.1		μA	
V _{CE2H}	CE2 input voltage, high	V _{IN} = 5.5 V	1.0			V	
V _{CE2L}	CE2 input voltage, low	V _{IN} = 1.8 V			0.4	V	
R _{DISNBM}	Auto-discharge NMOS. on-resistance	V _{IN} = 4.0 V, V _{CE2} = 0 V		50		Ω	

All test items listed under Electrical Characteristics are done under the pulse load condition (T_j ≈ T_a = 25°C)

Product-specific Electrical Characteristics**(Ta = 25°C)**

Product Name	V _{OUT} [V]		
	Min.	Typ.	Max.
RP605x16xx	1.576	1.600	1.624
RP605x18xx	1.773	1.800	1.827
RP605x20xx	1.970	2.000	2.030
RP605x24xx	2.364	2.400	2.436
RP605x25xx	2.463	2.500	2.537
RP605x28xx	2.758	2.800	2.842
RP605x30xx	2.955	3.000	3.045
RP605x31xx	3.054	3.100	3.146
RP605x33xx	3.251	3.300	3.349
RP605x36xx	3.546	3.600	3.654
RP605x40xx	3.940	4.000	4.060
RP605x52xx	5.122	5.200	5.278

TYPICAL APPLICATION CIRCUIT

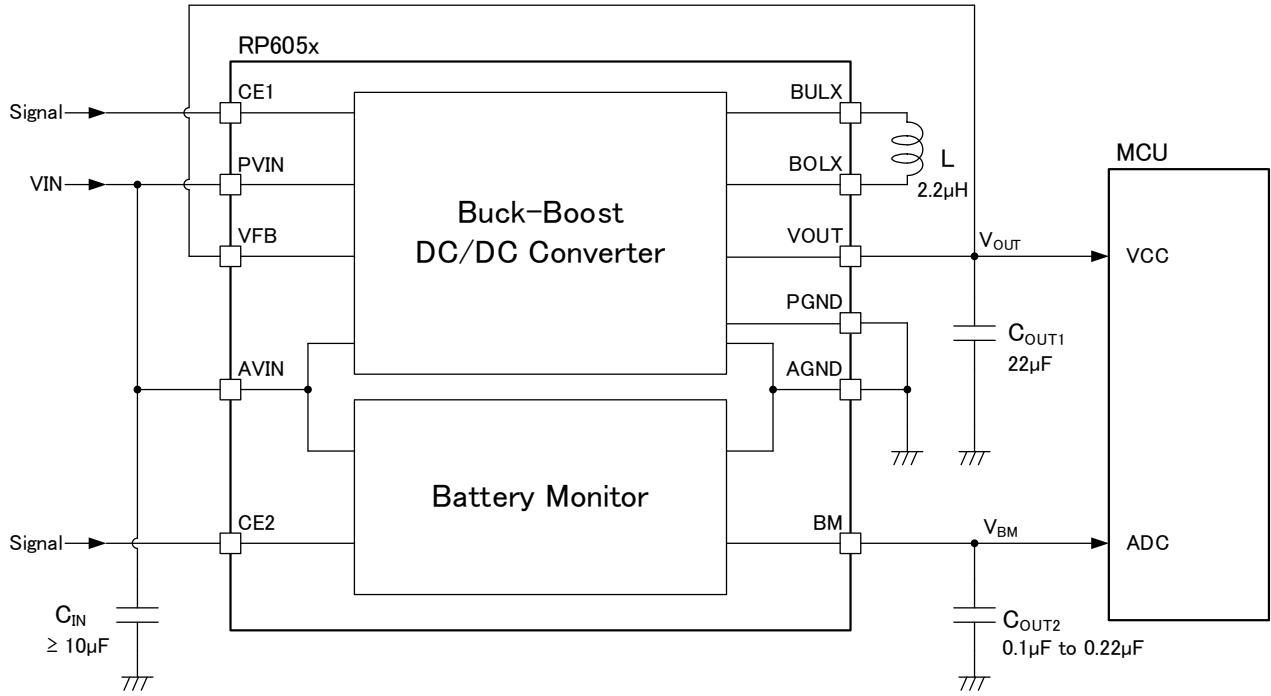

RP605x Typical Application Circuit

TECHNICAL NOTES

The performance of a power source circuit using this device is highly dependent on the peripheral circuit. A peripheral component or the device mounted on PCB should not exceed a rated voltage, a rated current or a rated power. When designing a peripheral circuit, please be fully aware of the following points.

- Use carefully with the distance between the VFB pin and the wiring that causes noise.
- Noise reduction is possible by adding a filter component such as a resistor to the VFB pin
- Use ceramic capacitors with a low equivalent series resistance (ESR), considering the bias characteristics and input/output voltages.
- When the built-in switches are turned off, the inductor may generate a spike-shaped high voltage. Use the high-breakdown voltage capacitor (C_{OUT1}) which output voltage is 1.5 times or more than the set output voltage.
- Use an inductor that has a low DC resistance, has an enough tolerable current and is less likely to cause magnetic saturation.
- The CE1 and CE2 pins are neither pulled up nor pulled down, therefore an operation is not stable at open.
- The thermal shutdown function protects the IC from fuming and ignition but does not ensure the IC's reliability or keep the IC below the absolute maximum ratings. The thermal shutdown function only works on the heat generated by normal IC operation such as latch-up and overvoltage application.
- The thermal shutdown function operates in a state over the absolute maximum ratings, therefore the thermal shutdown function should not be used for a system design.

THEORY OF OPERATION

DC/DC Section

Soft-start Time

Starting-up with CE1 Pin

The IC starts to operate when the CE1 pin voltage (V_{CE1}) exceeds the threshold voltage. The threshold voltage is preset between CE1 “High” input voltage (V_{CE1H}) and CE1 “Low” input voltage (V_{CE1L}). After the start-up of the IC, soft-start circuit starts to operate. Then, after a certain period, the reference voltage (V_{REF}) in the IC gradually increases up to the specified value. Switching starts when V_{REF} reaches the preset voltage, and after that the output voltage rises as V_{REF} increases. Soft-start time (t_{START}) indicates the period from the time soft-start circuit gets activated to the time V_{REF} reaches the specified voltage. t_{START} is not always equal to the turn-on speed of the DC/DC converter. Note that the turn-on speed could be affected by the power supply capacity, the output current (I_{OUT}), the inductance and the output capacitor value (C_{OUT1}).

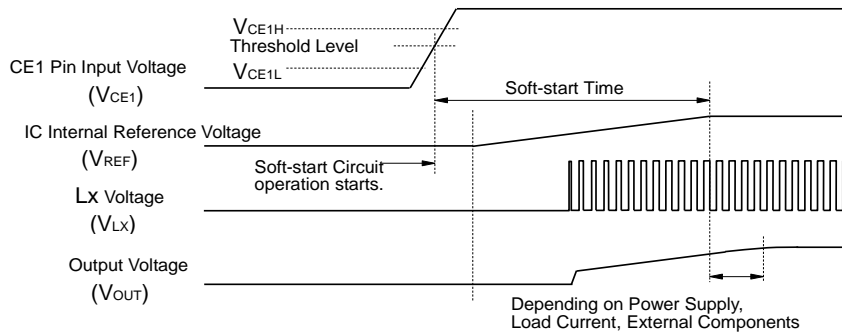

Timing Chart: Starting-up with CE1 Pin

Starting-up with Power Supply

After the power-on, when V_{IN} exceeds the UVLO release voltage (V_{UVLOR}), the IC starts to operate. Then, soft-start circuit starts to operate and after a certain period, V_{REF} gradually increases up to the specified value. Switching starts when V_{REF} reaches the preset voltage, and after that the output voltage rises as V_{REF} increases. The turn-on speed of V_{OUT} could be affected by following conditions:

1. The V_{IN} turn-on speed determined by the power supply to the IC and the C_{IN}
2. The output capacitor value (C_{OUT1}) and the output current (I_{OUT})

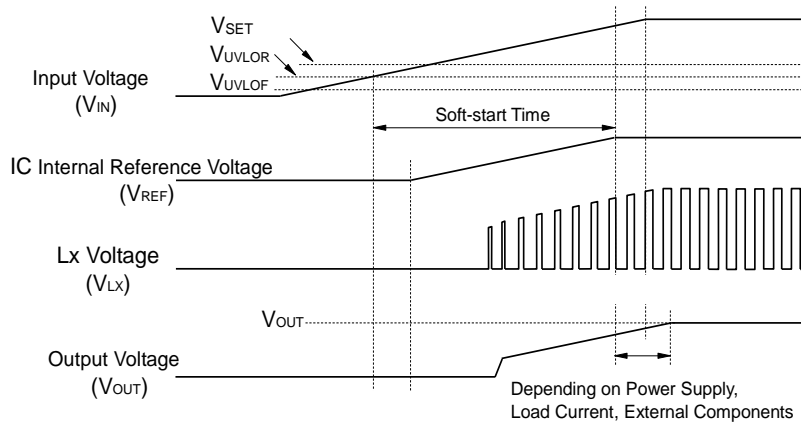

Timing Chart: Starting-up with Power Supply

Undervoltage Lockout (UVLO) Circuit

If the V_{IN} becomes lower than the UVLO detector threshold (V_{UVLOF}), the UVLO circuit starts to operate, V_{REF} stops, and PMOS and NMOS built-in switch transistors turn "OFF". To restart the operation, V_{IN} needs to be higher than V_{UVLOR} .

Overvoltage Protection (OVP) Circuit

If the V_{OUT} becomes higher than the OVP detector threshold (V_{OVP}), the OVP circuit starts to operate and turns off the built-in switch transistors. As a result, V_{OUT} drops according to the C_{OUT} capacitance value and the load.

Overcurrent Protection Circuit

Overcurrent protection circuit supervises the inductor peak current (the peak current flowing through PMOS Tr (SW1) in each switching cycle, and if the current exceeds the BULX current limit (I_{LXLIM}), it turns off PMOS Tr (SW1). I_{LXLIM} of the RP605x is set to Typ. 0.9 A.

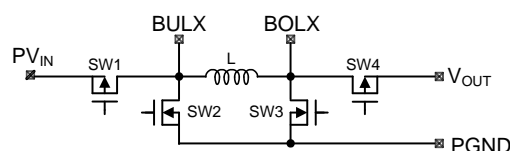

Simplified Diagram of Output Switches

Thermal Shutdown Circuit

When the junction temperature exceeds the thermal shutdown detector threshold T_{TSD} (Typ. 140°C), the output of the DC/DC section is shut off and self-heating is suppressed. The DC/DC restarts when the junction temperature falls below the thermal shutdown release threshold T_{TSR} (Typ. 100°C), and the soft-start function is operated like as CE1's start-up.

RP605x

No. EA-516-200226

VFM Mode

The VFM (Variable Frequency Modulation) mode is adopted as a switching method to achieve a high efficiency under light load conditions. A switching frequency varies depending on values of input voltage (V_{IN}), output voltage (V_{OUT}), and output current (I_{OUT}). Check the actual characteristics to avoid the switching noise.

A switching starts when V_{OUT} drops below the lower-limit reference voltage (V_{REFL}). When V_{OUT} exceeds the upper-limit reference voltage (V_{REFH}), a constant voltage is output by a hysteresis control which stops the switching.

In order to operate within the rated characteristic of inductor and avoid the deteriorated band frequency of DC superimposed characteristics, when the inductor current (I_L) exceeds LX current limit (I_{LXLIM}), the operation shifts to off-cycle. And when I_L drops below the valley current limit (I_{LXVAL}), the operation shifts to on-cycle.

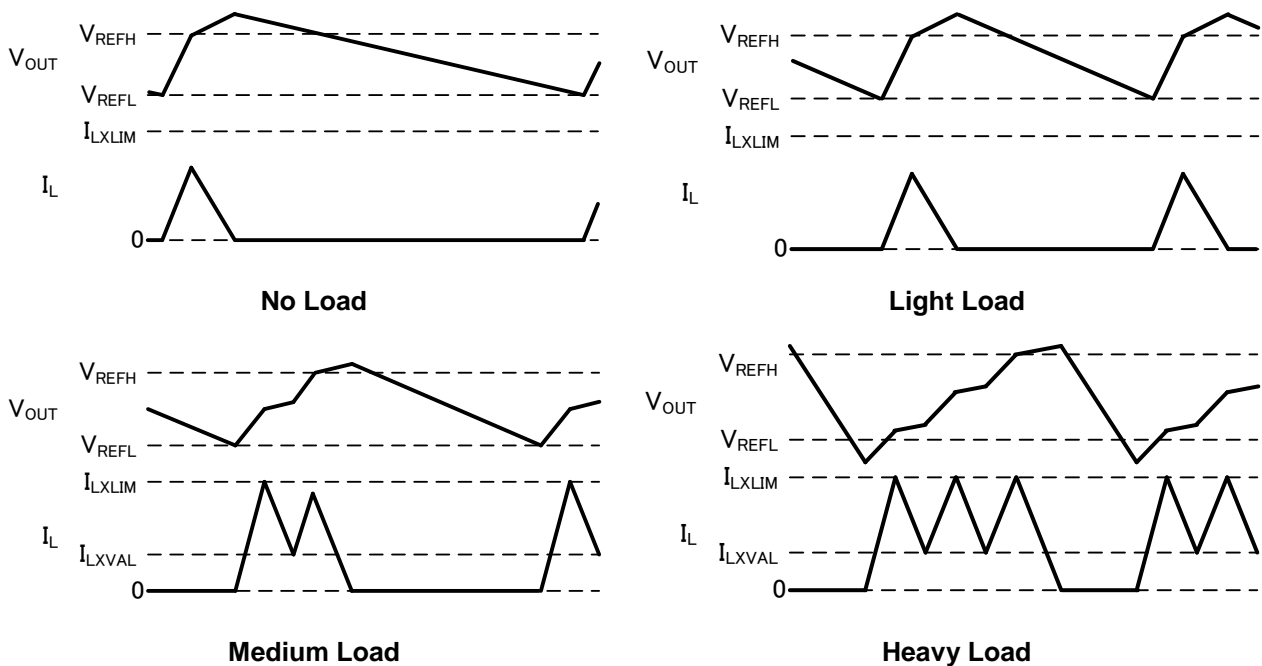

Battery Monitor Section
Timing Chart of Typical Application Circuit

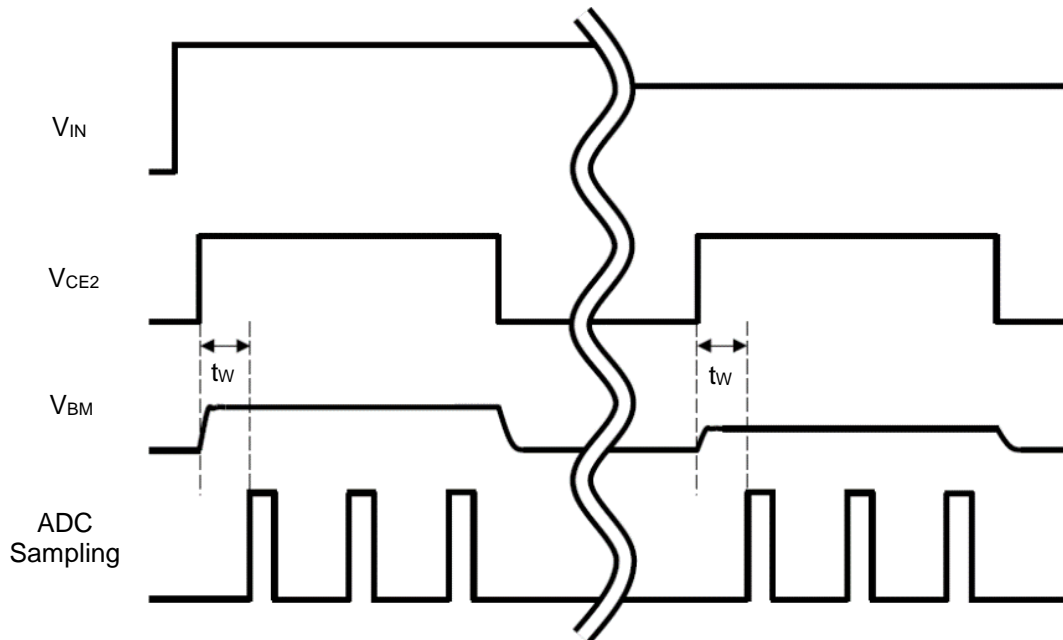

RP605x Timing Chart of Typical Application Circuit

The RP605x can monitor the battery voltage by connecting BM pin with ADC input pin in MCU. The RP605x allows the CE2 pin to control the battery monitor's start and stop according to the sampling cycle from the ADC, reducing the power consumption of the entire system.

During the battery voltage monitoring, waiting time (t_w) is needed, recommended $t_w \geq 10\text{ms}$, for the CE2 pin to gain stable V_{BM} .

RP605x

No. EA-516-200226

APPLICATION INFORMATION

PCB Layout

RP605Z (Package: WLCSP-20-P3) PCB Layout

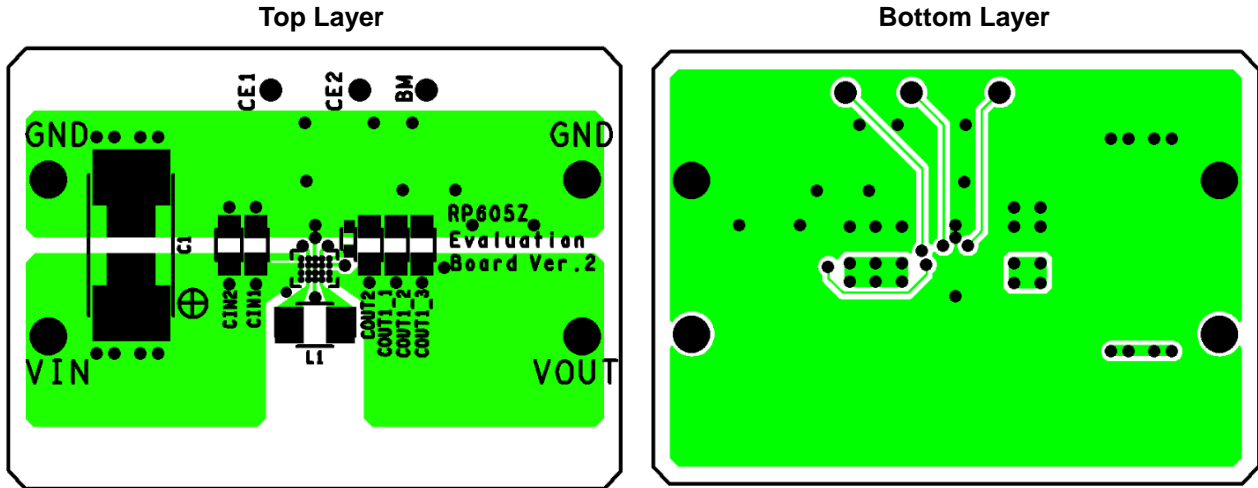

RP605K (Package: DFN(PLP)2730-12) PCB Layout

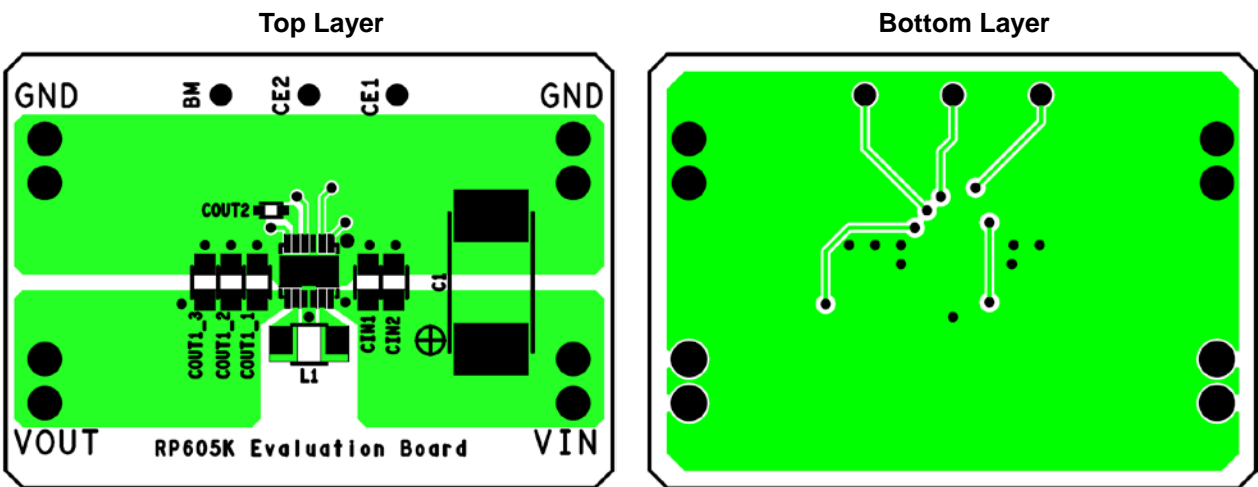

TYPICAL CHARACTERISTICS

Note: Typical Characteristics are intended to be used as reference data; they are not guaranteed.

DC/DC Section

1) Efficiency vs. Output Current

RP605x33xx, Ta = 25°C

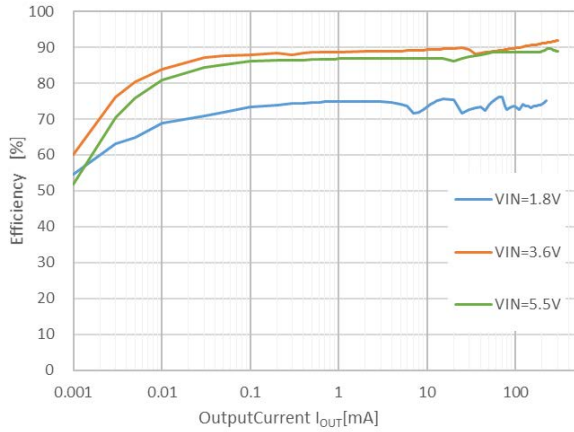

2) Output Voltage vs. Output Current

RP605x33xx, Ta = 25°C

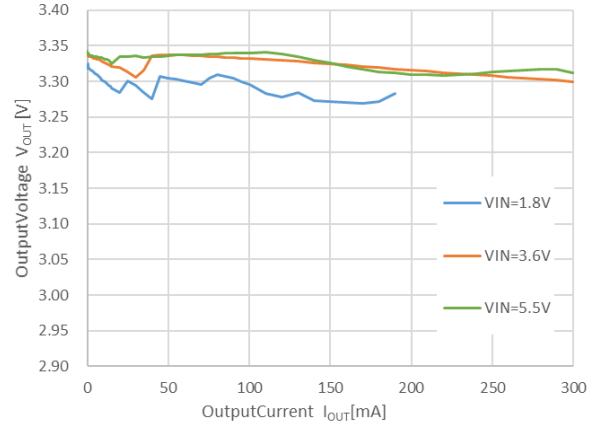

3) Standby Current vs. Temperature

RP605x33xx, VIN = 5.5V

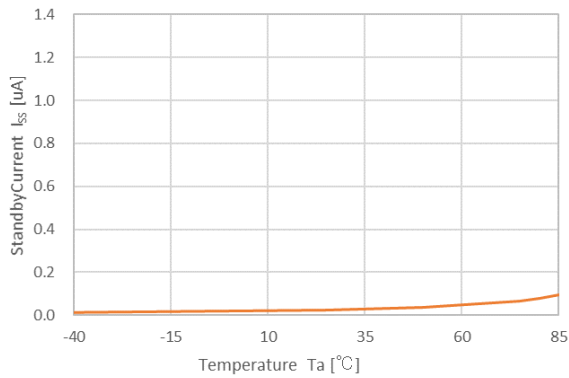

RP605x

No. EA-516-200226

4) Output Current vs. Input Voltage

RP605x16xx, $V_{IN} = 1.8$ to $3.6V$, $I_{OUT} = (I_{IN} = 300mA)$

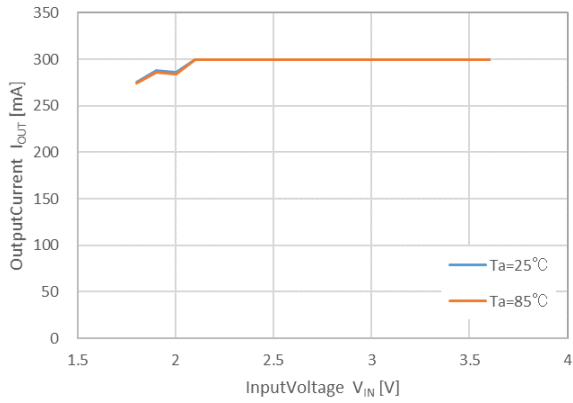

RP605x33xx, $V_{IN} = 1.8$ to $5.5V$, $I_{OUT} = (I_{IN} = 300mA)$

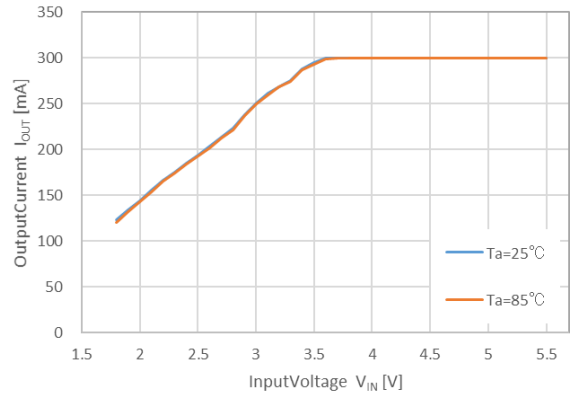

RP605x52xx, $V_{IN} = 2.3$ to $5.5V$, $I_{OUT} = (I_{IN} = 300mA)$

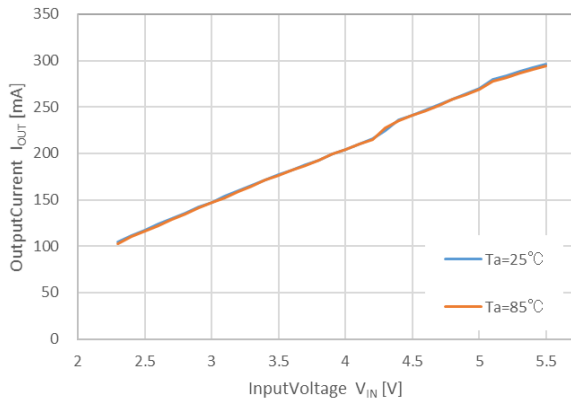

5) Output Ripple vs. Output Current

RP605x33xx, $T_a = 25^\circ C$

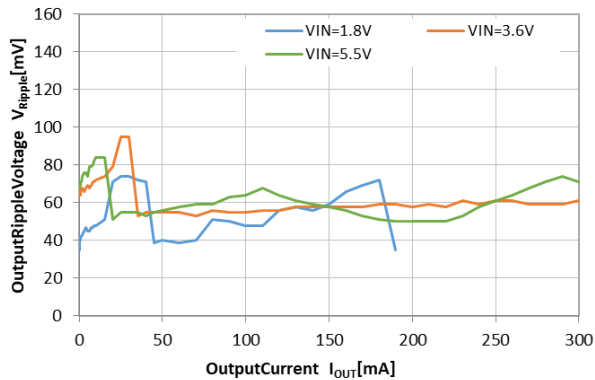

6) Output Voltage vs. Input Voltage

RP605x33xx, $I_{OUT} = 1\text{mA}$, $T_a = 25^\circ\text{C}$

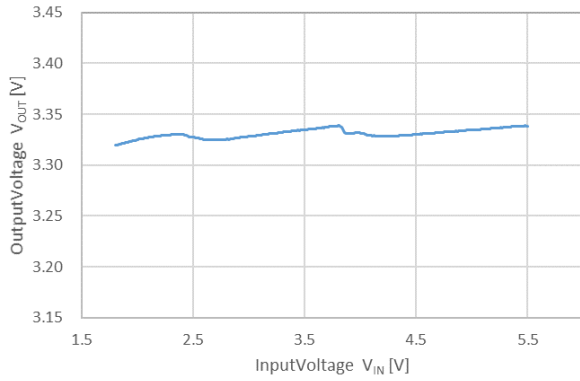

RP605x33xx, $I_{OUT} = 100\text{mA}$, $T_a = 25^\circ\text{C}$

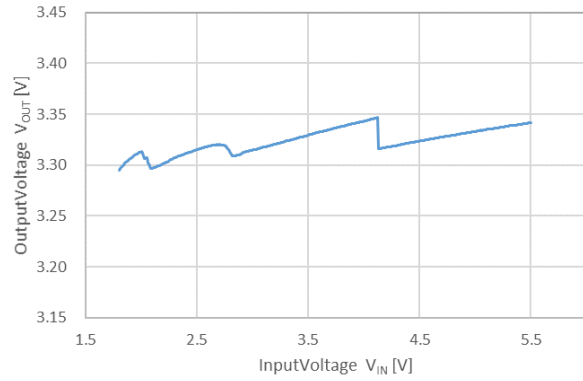

7) Starting-up/ Shutting-down Waveform with CE1 Pin

RP605x33xB, $V_{IN} = 3.6\text{V}$, $CE1 = 0\text{V} \leftrightarrow 3.6\text{V}$, $I_{OUT} = 0\text{mA}$, $T_a = 25^\circ\text{C}$

(at Starting-up)

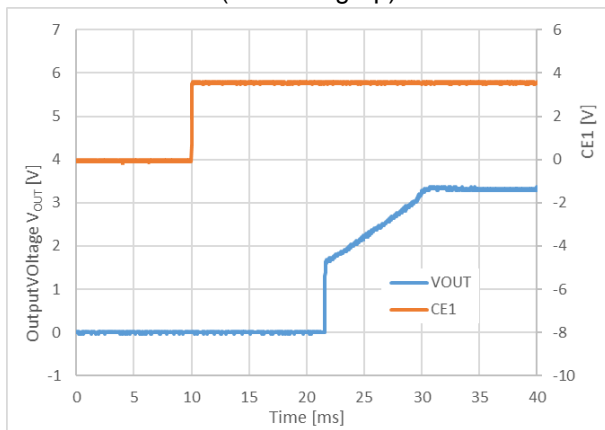

(at Shutting-down)

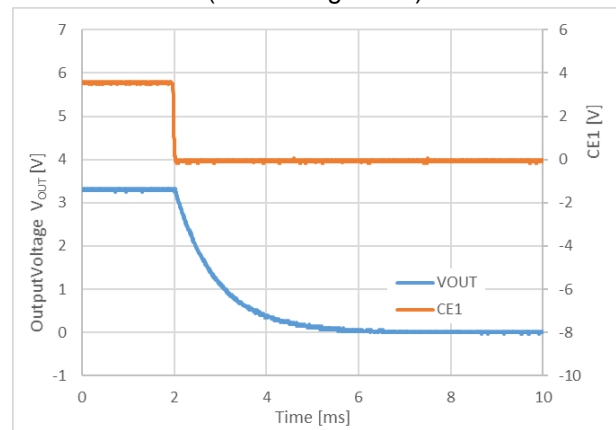

8) VOUT Pin Waveform

RP605x33xx, $V_{IN} = 3.6\text{V}$, $I_{OUT} = 10\text{mA}$, $T_a = 25^\circ\text{C}$

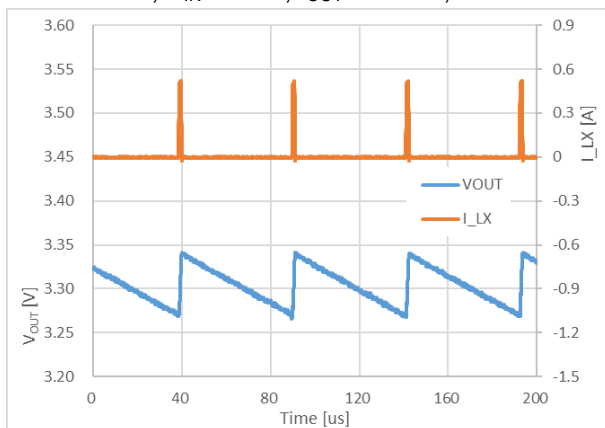

RP605x33xx, $V_{IN} = 3.6\text{V}$, $I_{OUT} = 100\text{mA}$, $T_a = 25^\circ\text{C}$

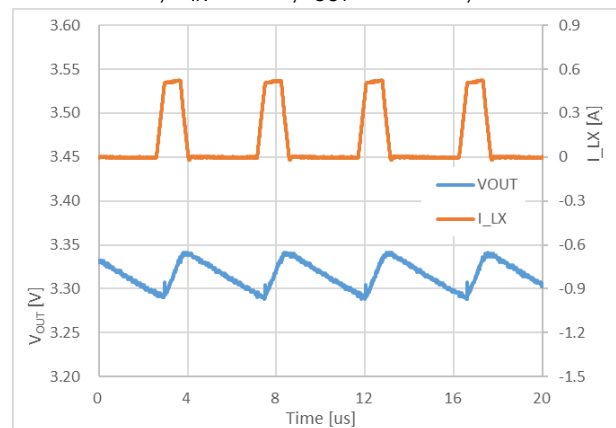

RP605x

No. EA-516-200226

9) Load Transient Response

RP605x33xx, $V_{IN} = 3.6V$, $I_{OUT} = 0.01mA \leftrightarrow 100mA$, $T_a = 25^\circ C$

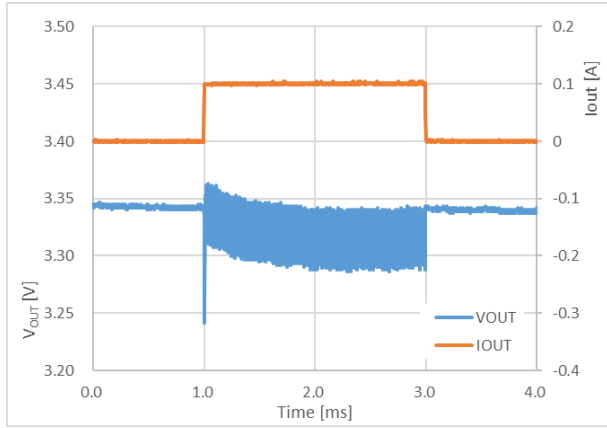

10) Input Transient Response

RP605x33xx, $V_{IN} = 2.5V \leftrightarrow 4.5V$, $I_{OUT} = 1mA$, $T_a = 25^\circ C$

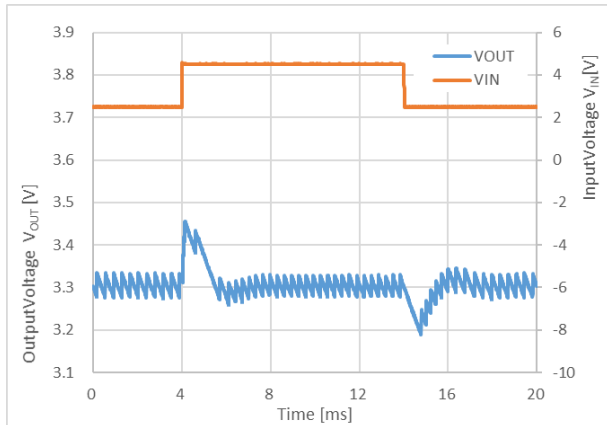

RP605x33xx, $V_{IN} = 2.5V \leftrightarrow 4.5V$, $I_{OUT} = 100mA$, $T_a = 25^\circ C$

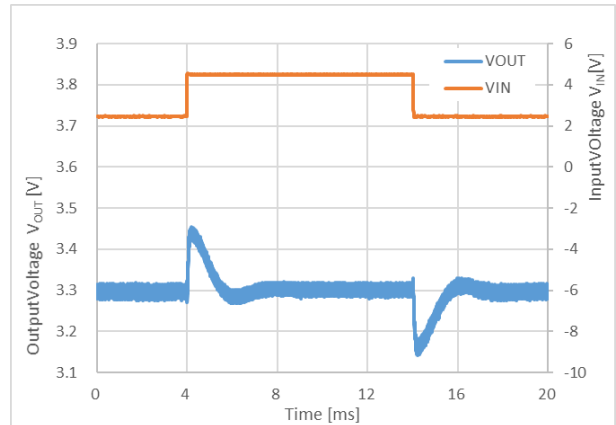

11) Supply Current vs. Temperature

RP605x33xx

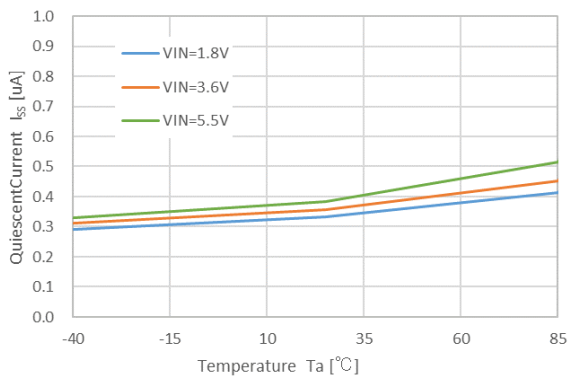

Battery Monitor Section

12) Output Voltage vs. Temperature

RP605xxx3x, $V_{IN} = 3.6V$

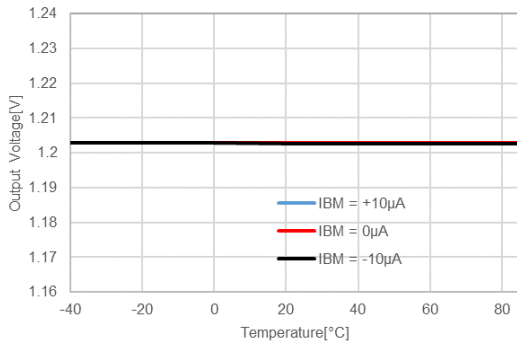

RP605xxx4x, $V_{IN} = 3.6V$

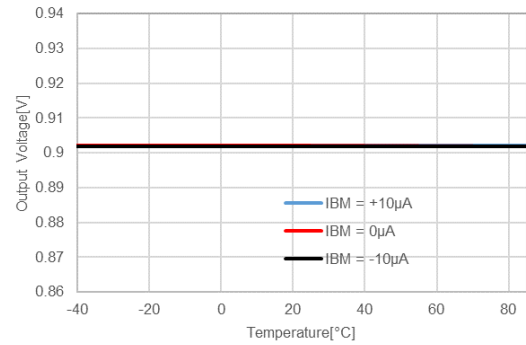

13) Output Voltage vs. Input Voltage

RP605xxx3x, $V_{IN} = 5.5V$ to Minimum Voltage, $T_a = 25^\circ C$

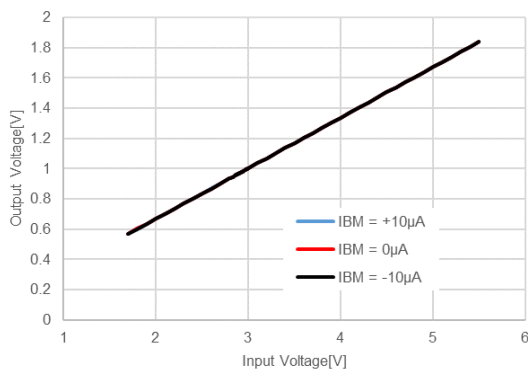

RP605xxx4x, $V_{IN} = 5.5V$ to Minimum Voltage, $T_a = 25^\circ C$

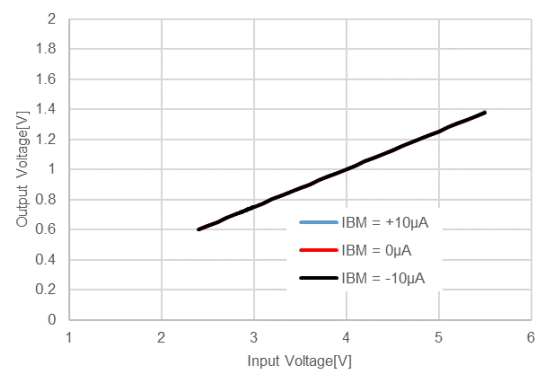

14) Supply Current vs. Temperature

RP605xxx3x, $V_{IN} = 3.6V$

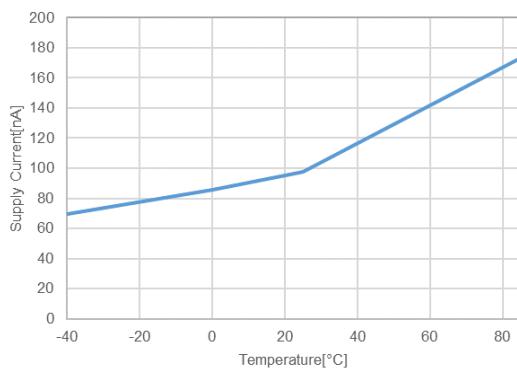

RP605xxx4x, $V_{IN} = 3.6V$

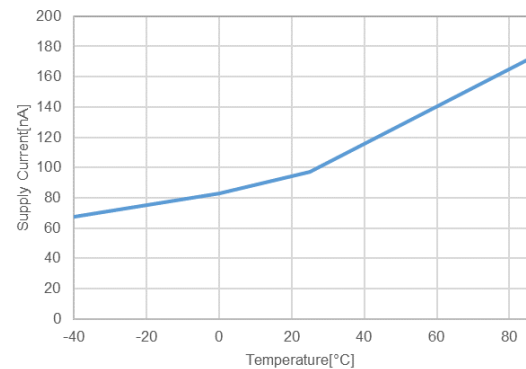

RP605x

No. EA-516-200226

15) Supply Current vs. Input Voltage

RP605xxx3x, $V_{IN} = 5.5V$ to Minimum Voltage, $T_a = 25^\circ C$

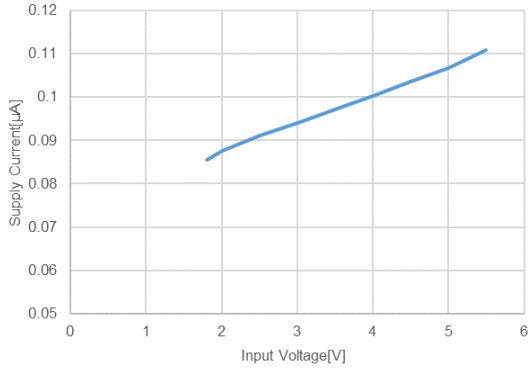

RP605xxx4x, $V_{IN} = 5.5V$ to Minimum Voltage, $T_a = 25^\circ C$

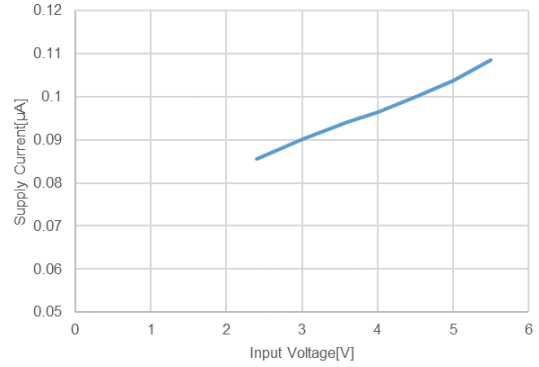

16) Starting-up/ Shutting-down Waveform with CE2 Pin

RP605xxx3x, $V_{IN} = 3.6V$, $T_a = 25^\circ C$

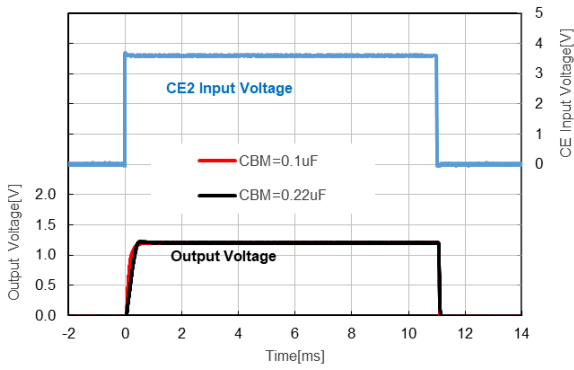

RP605xxx4x, $V_{IN} = 3.6V$, $T_a = 25^\circ C$

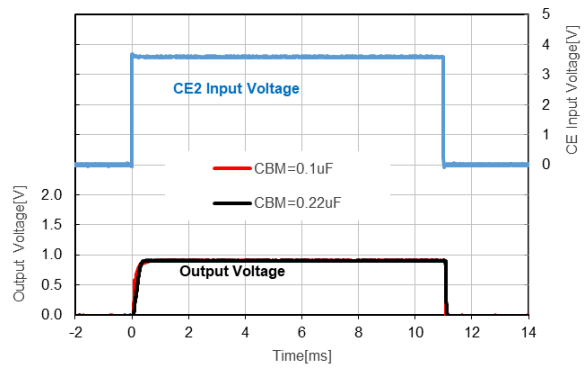

RP605xxx3x, $V_{IN} = 5.5V$, $T_a = 25^\circ C$

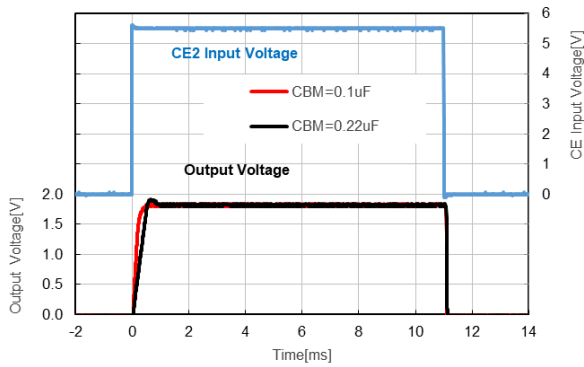

RP605xxx4x, $V_{IN} = 5.5V$, $T_a = 25^\circ C$

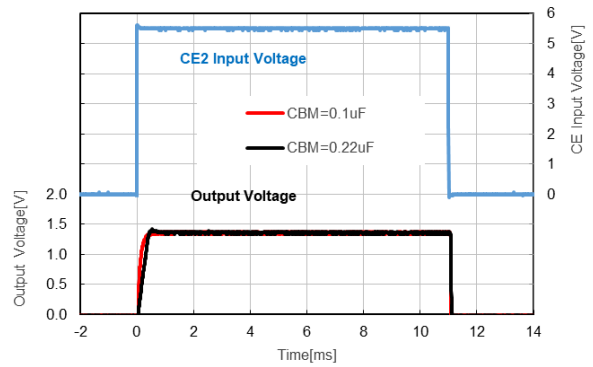

Test Circuit

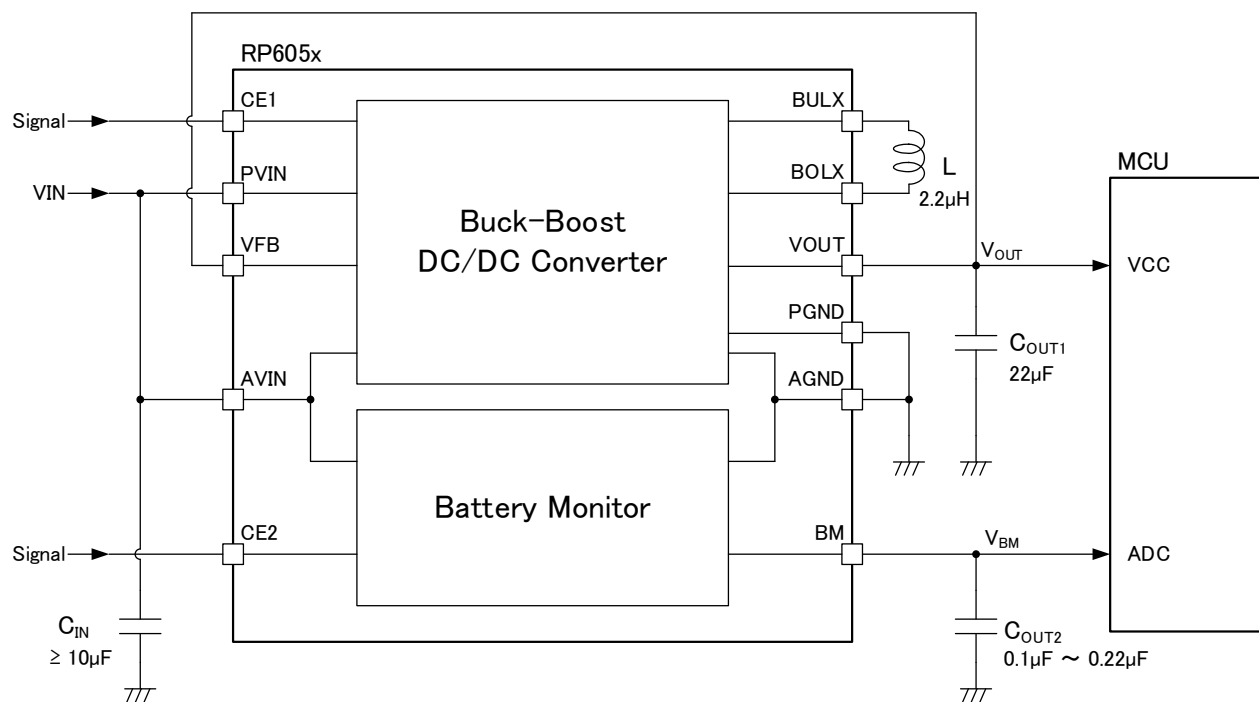

Test Circuit for Typical Characteristics

Measurement Components

Symbol	Capacitance	Manufacture	Parts number
C _{IN}	10µF	Murata	GRM155R60J106M
C _{OUT1}	22µF	Taiyo Yuden	JMK107BBJ226MA
C _{OUT2}	0.1µF	Murata	GRM155R61A104K
L	2.2µH	TDK	MLP2520H2R2ST0S1

Measurement Components for Typical Characteristics

The power dissipation of the package is dependent on PCB material, layout, and environmental conditions. The following measurement conditions are based on JEDEC STD. 51.

Measurement Conditions

Item	Measurement Conditions
Environment	Mounting on Board (Wind Velocity = 0 m/s)
Board Material	Glass Cloth Epoxy Plastic (Four-Layer Board)
Board Dimensions	101.5 mm x 114.5 mm x 1.6 mm
Copper Ratio	Outer Layer (First Layer): 10% Inner Layers (Second and Third Layers): 99.5 x 99.5mm 100% Outer Layer (Fourth Layer): 10%

Measurement Result

(Ta = 25°C, Tjmax = 125°C)

Item	Measurement Result
Power Dissipation	1210 mW
Thermal Resistance (θ_{ja})	$\theta_{ja} = 82^\circ\text{C/W}$

θ_{ja} : Junction-to-Ambient Thermal Resistance

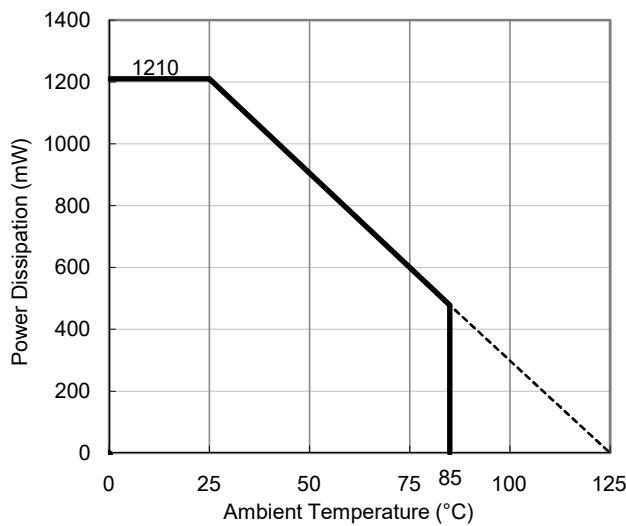

Power Dissipation vs. Ambient Temperature

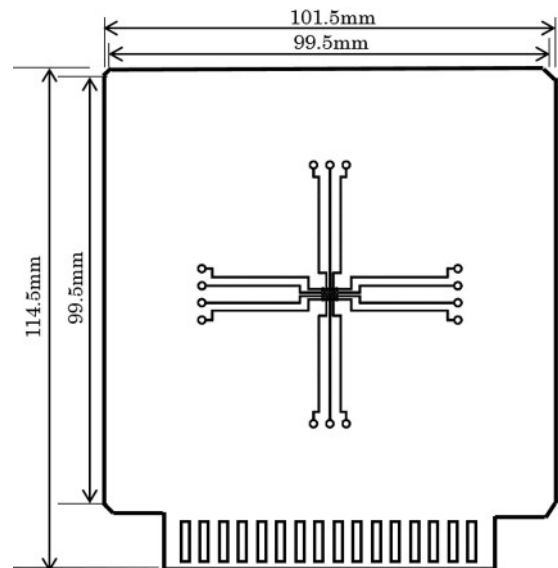

Measurement Board Pattern

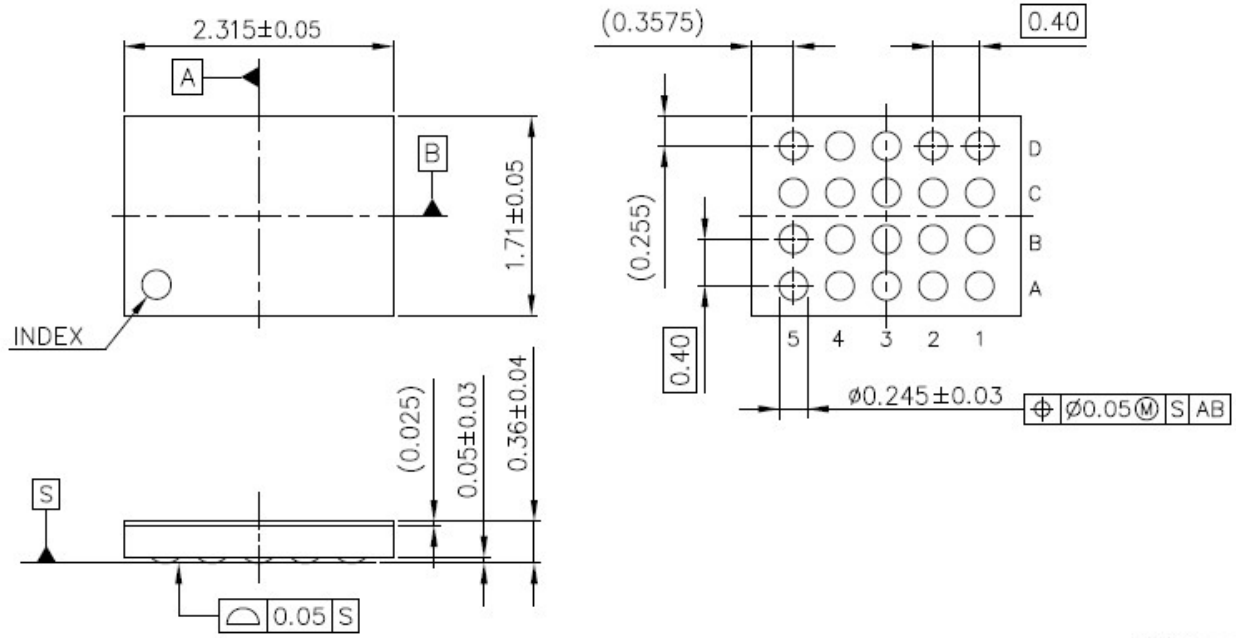

UNIT: mm

WLCSP-20-P3 Package Dimensions

The power dissipation of the package is dependent on PCB material, layout, and environmental conditions. The following measurement conditions are based on JEDEC STD. 51-7.

Measurement Conditions

Item	Measurement Conditions
Environment	Mounting on Board (Wind Velocity = 0 m/s)
Board Material	Glass Cloth Epoxy Plastic (Four-Layer Board)
Board Dimensions	76.2 mm × 114.3 mm × 0.8 mm
Copper Ratio	Outer Layer (First Layer): Less than 95% of 50 mm Square Inner Layers (Second and Third Layers): Approx. 100% of 50 mm Square Outer Layer (Fourth Layer): Approx. 100% of 50 mm Square
Through-holes	φ 0.3 mm × 23 pcs

Measurement Result

(Ta = 25°C, Tjmax = 125°C)

Item	Measurement Result
Power Dissipation	3100 mW
Thermal Resistance (θja)	θja = 32°C/W
Thermal Characterization Parameter (ψjt)	ψjt = 8°C/W

θja: Junction-to-Ambient Thermal Resistance

ψjt: Junction-to-Top Thermal Characterization Parameter

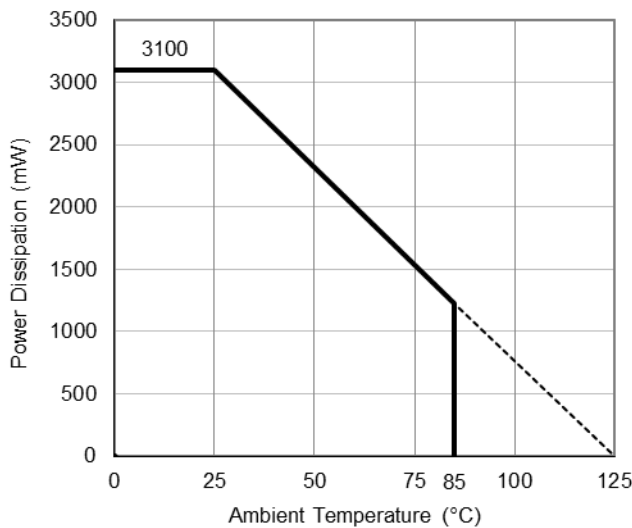

Power Dissipation vs. Ambient Temperature

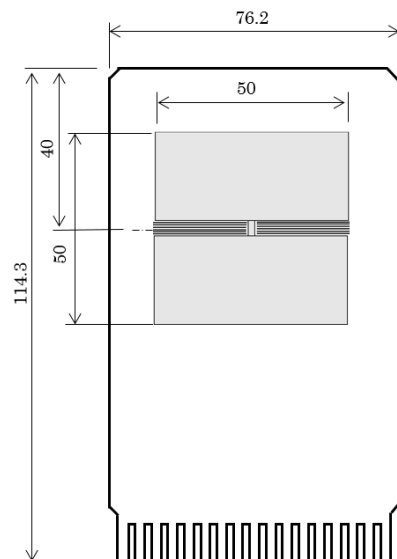

Measurement Board Pattern

PACKAGE DIMENSIONS

DFN(PLP)2730-12

DM-DFN(PNP)2730-12-JE-B

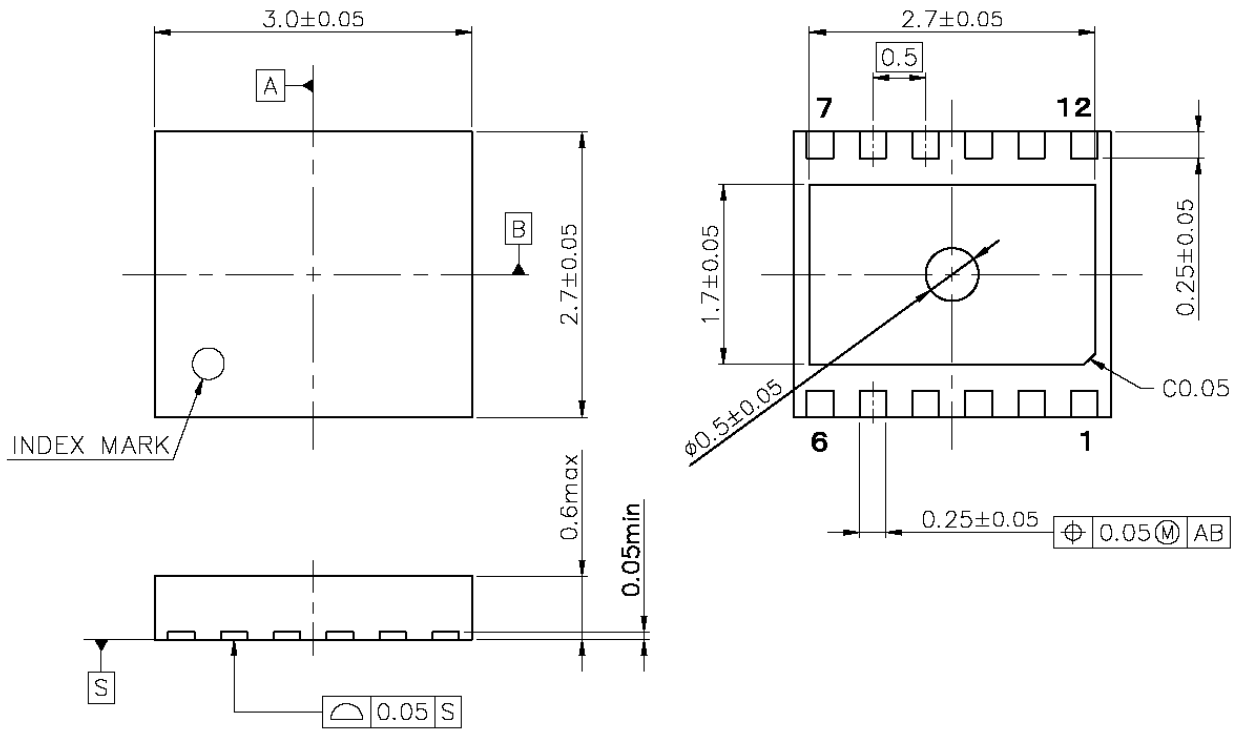

DFN(PLP)2730-12 Package Dimensions (Unit: mm)



1. The products and the product specifications described in this document are subject to change or discontinuation of production without notice for reasons such as improvement. Therefore, before deciding to use the products, please refer to Ricoh sales representatives for the latest information thereon.
2. The materials in this document may not be copied or otherwise reproduced in whole or in part without prior written consent of Ricoh.
3. Please be sure to take any necessary formalities under relevant laws or regulations before exporting or otherwise taking out of your country the products or the technical information described herein.
4. The technical information described in this document shows typical characteristics of and example application circuits for the products. The release of such information is not to be construed as a warranty of or a grant of license under Ricoh's or any third party's intellectual property rights or any other rights.
5. The products listed in this document are intended and designed for use as general electronic components in standard applications (office equipment, telecommunication equipment, measuring instruments, consumer electronic products, amusement equipment etc.). Those customers intending to use a product in an application requiring extreme quality and reliability, for example, in a highly specific application where the failure or misoperation of the product could result in human injury or death (aircraft, spacevehicle, nuclear reactor control system, traffic control system, automotive and transportation equipment, combustion equipment, safety devices, life support system etc.) should first contact us.
6. We are making our continuous effort to improve the quality and reliability of our products, but semiconductor products are likely to fail with certain probability. In order to prevent any injury to persons or damages to property resulting from such failure, customers should be careful enough to incorporate safety measures in their design, such as redundancy feature, fire containment feature and fail-safe feature. We do not assume any liability or responsibility for any loss or damage arising from misuse or inappropriate use of the products.
7. Anti-radiation design is not implemented in the products described in this document.
8. The X-ray exposure can influence functions and characteristics of the products. Confirm the product functions and characteristics in the evaluation stage.
9. WLCSP products should be used in light shielded environments. The light exposure can influence functions and characteristics of the products under operation or storage.
10. There can be variation in the marking when different AOI (Automated Optical Inspection) equipment is used. In the case of recognizing the marking characteristic with AOI, please contact Ricoh sales or our distributor before attempting to use AOI.
11. Please contact Ricoh sales representatives should you have any questions or comments concerning the products or the technical information.



Ricoh is committed to reducing the environmental loading materials in electrical devices with a view to contributing to the protection of human health and the environment.

Ricoh has been providing RoHS compliant products since April 1, 2006 and Halogen-free products since April 1, 2012.

RICOH RICOH ELECTRONIC DEVICES CO., LTD.

Official website

<https://www.n-redc.co.jp/en/>

Contact us

<https://www.n-redc.co.jp/en/buy/>

