



## SPECIFICATION OF PRODUCT 承认书

CUSTOMER: \_\_\_\_\_

DESCRIPTION: Piezo Buzzer

FUSHENG P/N: FUET-1780

CUSTOMER P/N: \_\_\_\_\_

DATE: 2021-9-18

CUSTOMER	APPROVER	CHECKER
	Cui	Bing Yan

### 泰州福声电子科技有限公司

地址:江苏省泰州市海陵区凤凰西路 98 号

电话: +86-15996095712

邮箱: sales@electronic-tech.cn

网址: [www.tzfsdz.com](http://www.tzfsdz.com)

## 1.SPECIFICATION 规格

No.	Item	Unit	Specification	Condition
1	Oscillation Frequency	Hz	4000	square wave
2	Operating Voltage	V <sub>DC</sub>	3 ~ 20	
3	Rated Voltage	V <sub>DC</sub>	12	
4	Current Consumption	mA	MAX. 8	at Rated Voltage
5	Sound Pressure Level	dB	MIN. 83	at 10cm at Rated Voltage
6	Tone Nature		Single	
7	Operating Temperature	°C	-40 ~ +85	
8	Storage Temperature	°C	-40 ~ +85	
9	Dimension	mm	17 x 17 x H 7.5	See appearance drawing
10	Weight (MAX)	gram	2.6	
11	Housing Material		LCP( Black )	
12	Leading Pin		Plated Brass(Au)	See appearance drawing
13	Environmental Protection Regulation		RoHS	

## 2. APPEARANCE DRAWING 尺寸图

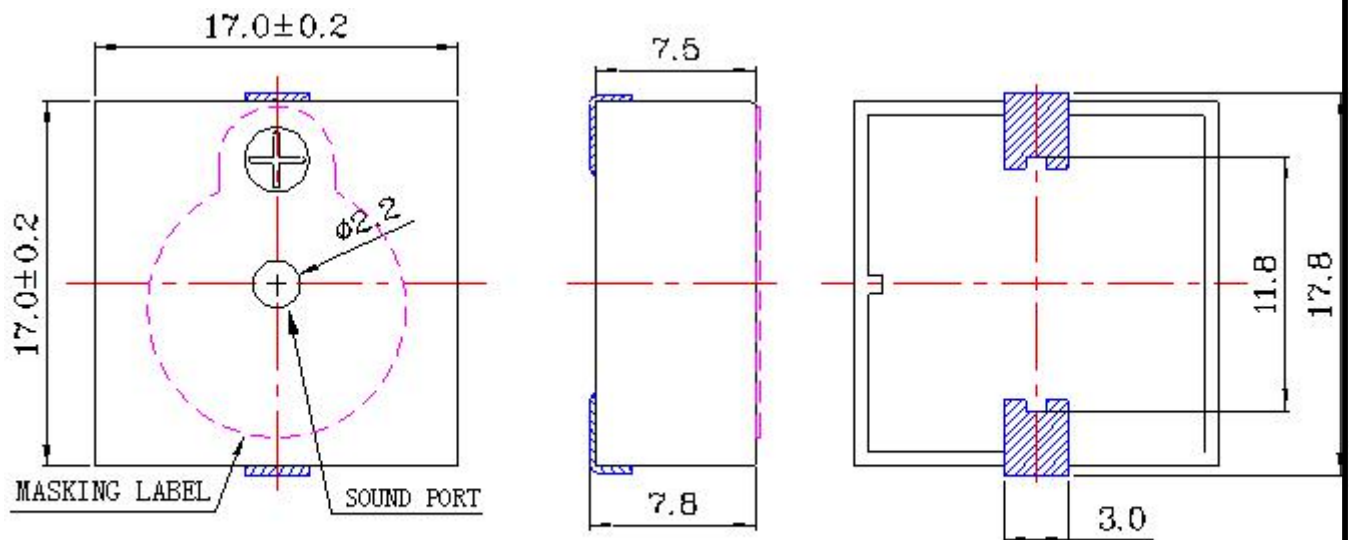

Tol :  $\pm 0.5$  Unit: mm

### 3.TESTING METHOD 测量方式

#### Standard Measurement conditions

Temperature:25±2°C Humidity:45-65%

#### Acoustic Characteristics:

The oscillation frequency, current consumption and sound pressure are measured by the measuring instruments

shown below.

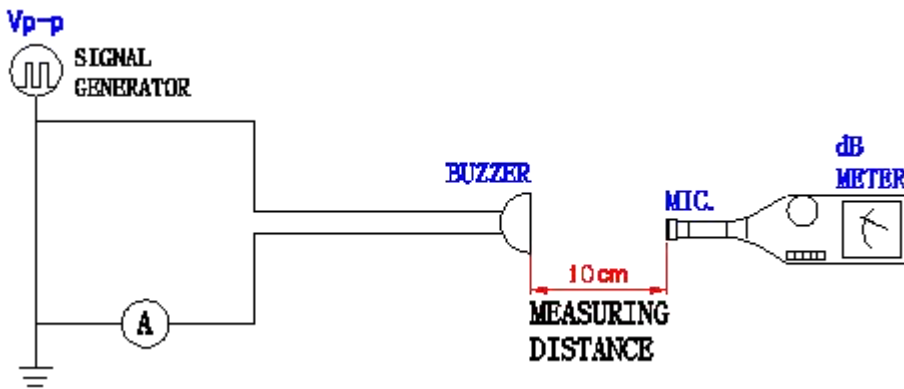

In the measuring test, buzzer is placed as follows:

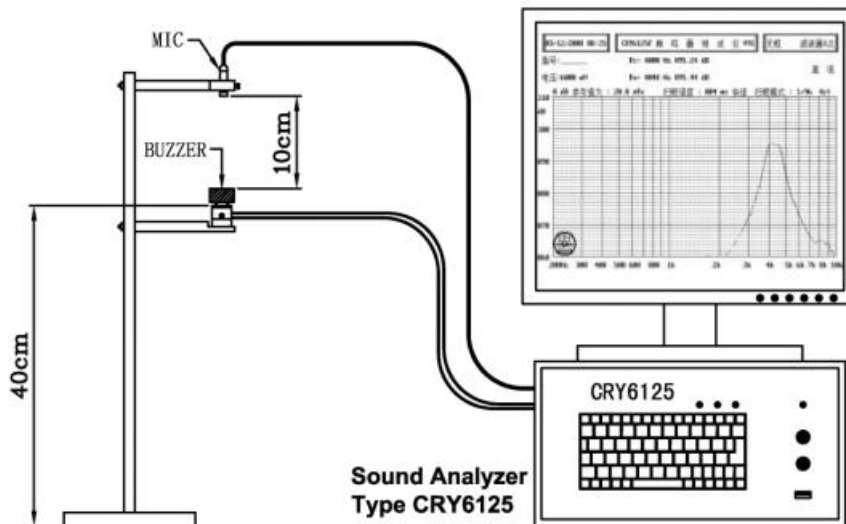

#### 4. Typical Frequency Response Curve

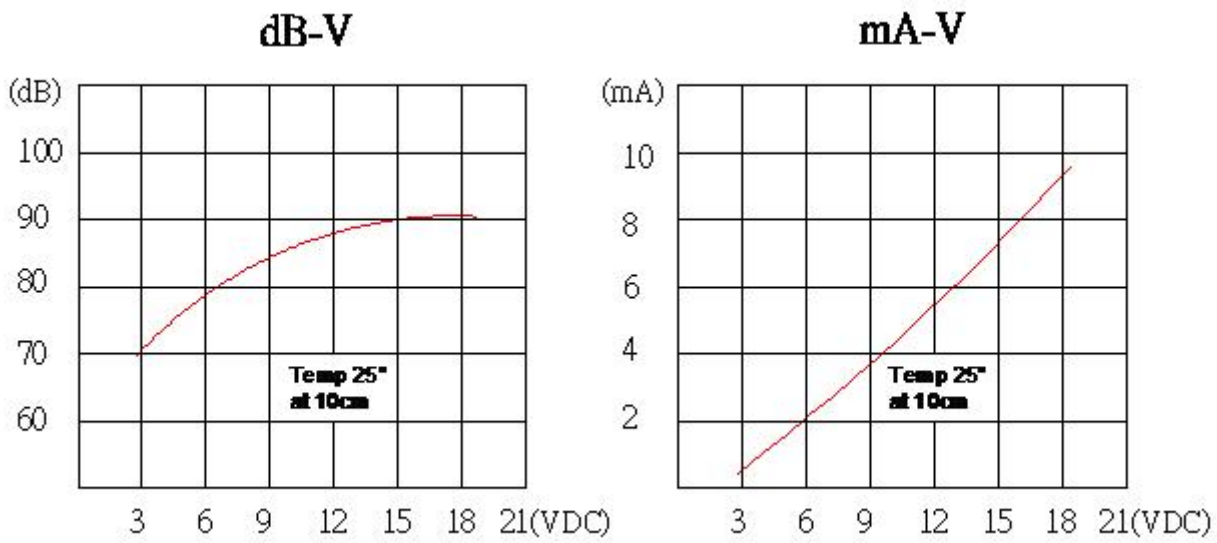

#### 5. Soldering Condition

(1) Recommendable reflow soldering condition is as follows

(Reflow soldering is twice)

Note: It is requested that reflow soldering should be executed after heat of product goes down to normal.

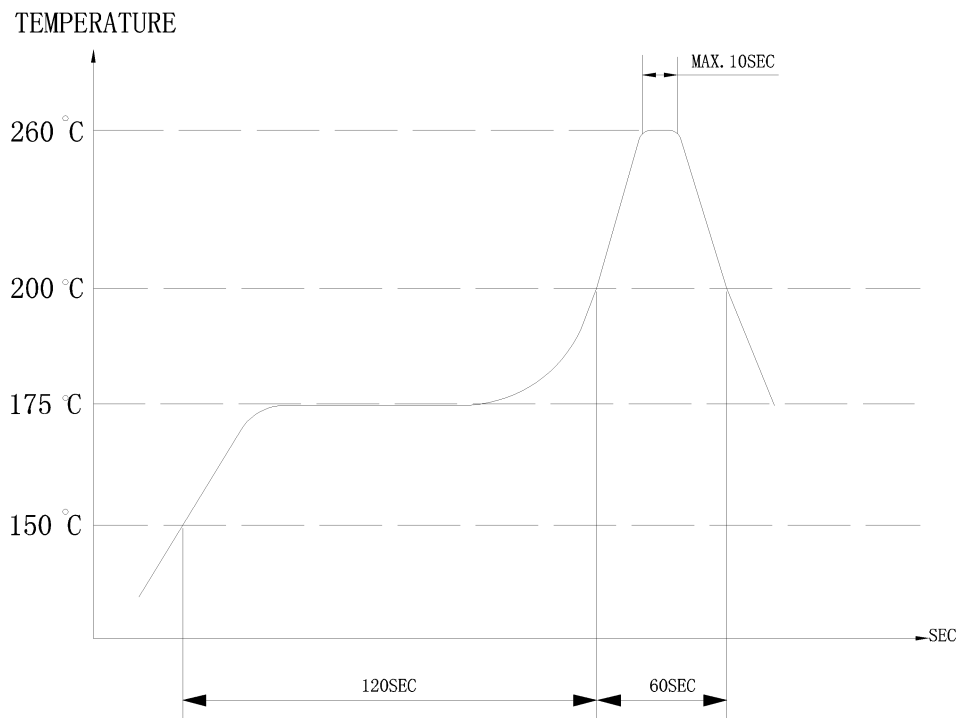

## 6. RELIABILITY TEST

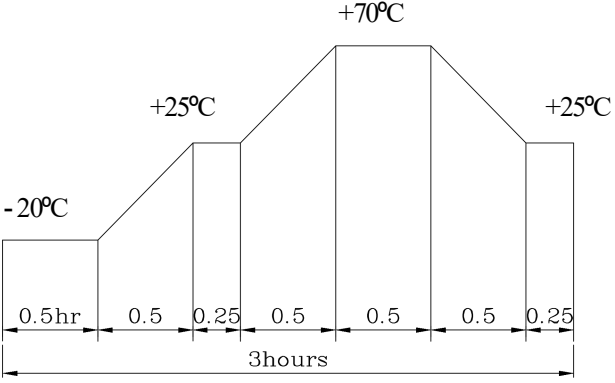
NO.	ITEM	TEST CONDITION AND REQUIREMENT
1	High Temperature Test (Storage)	After being placed in a chamber with 80 °C for 96 hours and then being placed in normal condition for 2 hours. Allowable variation of SPL after test: 10dB.
2	Low Temperature Test (Storage)	After being Placed in a chamber with -30 °C for 96 hours and then being placed in normal condition for 2 hours. Allowable variation of SPL after test: 10dB.
3	Humidity Test	After being Placed in a chamber with 90-95% R.H. at 40 °C for 96 hours and then being placed in normal condition for 2 hours. Allowable variation of SPL after test: 10dB.
4	Temperature Cycle Test	The part shall be subjected to 5 cycles. One cycle shall be consist of:  <p>The diagram shows a temperature cycle profile over 3 hours. It starts at -20°C for 0.5 hours, then ramps up to +25°C in 0.5 hours, holds at +25°C for 0.25 hours, ramps up to +70°C in 0.5 hours, holds at +70°C for 0.5 hours, ramps down to +25°C in 0.5 hours, holds at +25°C for 0.25 hours, and finally ramps down to -20°C in 0.5 hours. The total duration is 3 hours.</p> Allowable variation of SPL after test: 10dB.
5	Drop Test	Drop on a hard wood board of 4cm thick, any directions ,6 times, at the height of 75cm . Allowable variation of SPL after test: 10dB.
6	Vibration Test	After being applied vibration of amplitude of 1.5mm with 10 to 55 Hz band of vibration frequency to each of 3 perpendicular directions for 2 hours . Allowable variation of SPL after test: 10dB.
7	Solderability Test	Lead terminals are immersed in rosin for 5 seconds and then immersed in solder bath of +300 °C for 3 1 seconds . 90% min. lead terminals shall be wet with solder (Except the edge of terminals).
8	Terminal Strength Pulling Test	The force of 9.8N(1.0kg) is applied to each terminal in axial direction for 10 seconds. No visible damage and cutting off.

### TEST CONDITION.

Standard Test Condition	:	a) Temperature : +5 ~ +35°C	b) Humidity : 45-85%	c) Pressure : 860-1060mbar
一般测试条件	:	a) 温度 : +5 ~ +35°C	b) 湿度 : 45-85%	c) 气压 : 860-1060mbar
Judgment Test Condition	:	a) Temperature : +25 ± 2°C	b) Humidity : 60-70%	c) Pressure : 860-1060mbar
争议时测试条件	:	a) 温度 : +25 ± 2°C	b) 湿度 : 60-70%	c) 气压 : 860-1060mbar

## 7. PACKING STANDARD

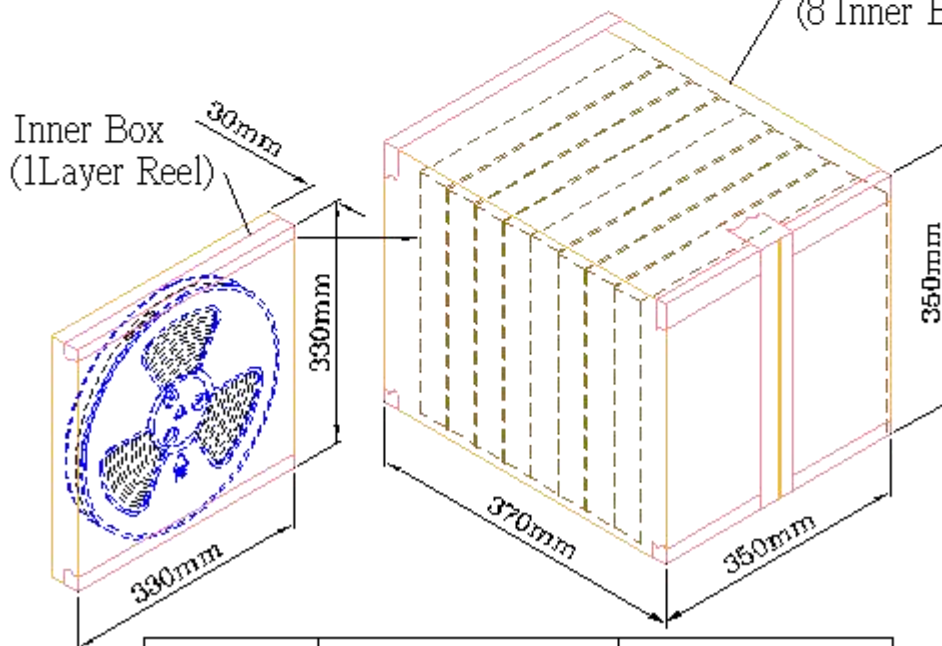
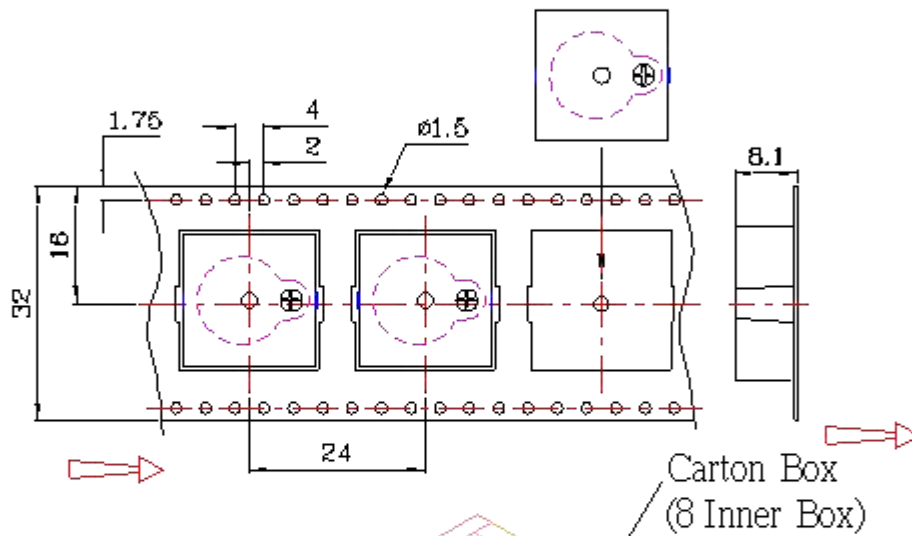
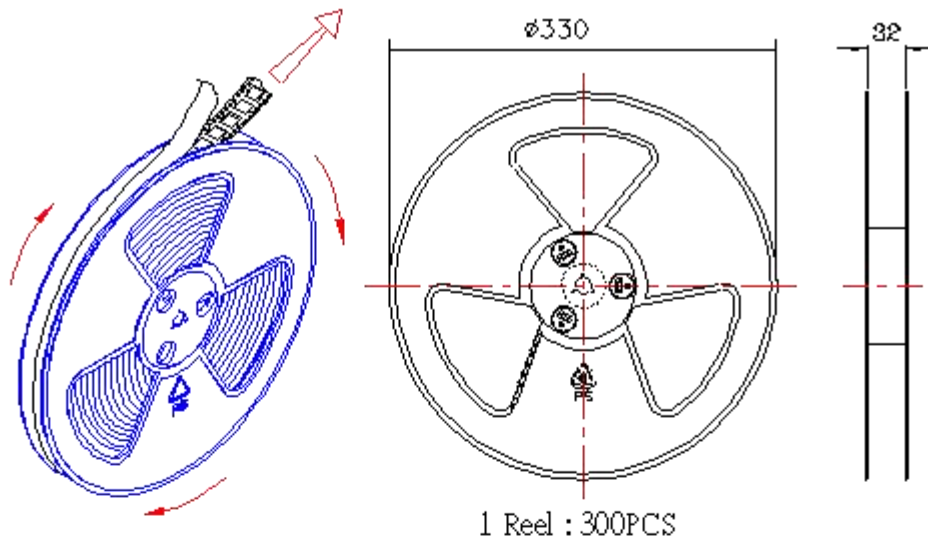

Inner Box	330mmx330mmx30mm	1x300PCS=300PCS
Carton Box	350mmx350mmx370mm	8x300PCS=2400PCS

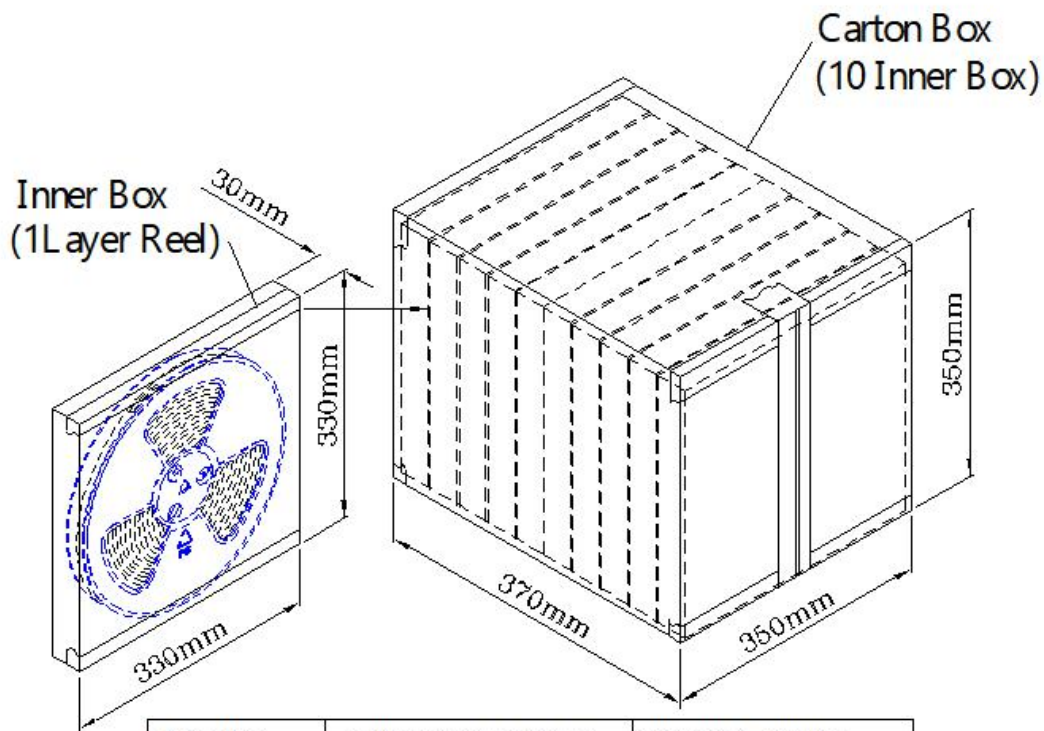

Inner Box	330mmx330mmx30mm	1x300PCS=300PCS
Carton Box	350mmx350mmx370mm	10x300PCS=3,000PCS