

Power Supply ICs for TFT-LCD Panels

5V Input Multi-channel System Power Supply ICs



BD8163EFV

No.10035EAT13

●Description

The BD8163EFV is a system power supply IC for TFT panels. A 1-chip IC providing a total of four voltages required for TFT panels, i.e., logic voltage, sauce voltage, gate high-level, and gate low-level voltage, thus constructing a TFT panel power supply with minimal components required.

●Features

- 1) Operates in an operating voltage range as low as 2.1 V to 6.0 V.
- 2) Incorporates a step-up DC/DC converter.
- 3) Incorporates a 2.5 V regulator.
- 4) Incorporates positive and negative-side charge pumps.
- 5) Switching frequency of 1100 kHz
- 6) DC/DC converter feedback voltage of $1.24\text{ V} \pm 1\%$
- 7) Incorporates a gate shading function
- 8) Under-voltage lockout protection circuit
- 9) Thermal shutdown circuit
- 10) Overcurrent protection circuit
- 11) HTSSOP-B24 package

●Applications

Liquid crystal TV, PC monitor, and TFT-LCD panel

●Absolute maximum ratings (Ta = 25°C)

Parameter	Symbol	Ratings	Unit
Power supply voltage	VCC	7	V
Vo1 voltage	Vo1	19	V
Vo2 voltage	Vo2	32	V
SW voltage	Vsw	19	V
Maximum junction temperature	Tjmax	150	°C
Power dissipation	Pd	1100*	mW
Operating temperature range	Topr	-40 to 125	°C
Storage temperature range	Tstg	-55 to 150	°C

* Reduced by 4.7 mW/°C over 25°C, when mounted on a glass epoxy board. (70 mm × 70 mm × 1.6 mm).

●Recommended Operating Ranges

Parameter	Symbol	Ratings		Unit
		Min.	Max.	
Power supply voltage	VCC	2.1	6	V
Vo1 voltage	Vo1	8	18	V
Vo2 voltage	Vsw	—	18	V
SW Current	Isw	—	1.8	A
Vo2 Current	Vo2	—	30	V

●Electrical Characteristics (Unless otherwise specified, VCC = 5 V; Vo1 = 15 V; Vo2 = 25 V; Ta = 25°C)

1 DC/DC Converter Block

Parameter	Symbol	Limits			Unit	Conditions
		Min.	Typ.	Max.		
[Soft start]						
Source current	I _{so}	6	10	14	μA	V _{ss} = 0.5 V
Sinking current	I _{si}	0.1	0.2	1.0	mA	V _{ss} = 0.5 V, VDD = 1.65 V
[Error amp]						
Input bias current 1	I _{FB1}	—	0.1	0.5	μA	
Feedback voltage 1	V _{FB1}	1.227	1.240	1.253	V	Buffer
Voltage gain	A _V	—	200	—	V/V	*
Sinking current	I _{ol}	25	50	100	μA	V _{FB} = 1.5 V V _{COMP} = 0.5 V
Source current	I _{oo}	-100	-50	-25	μA	V _{FB} = 1.0 V V _{COMP} = 0.5 V
[SW]						
ON resistance N-channel	R _{ON,N}	50	200	600	mΩ	*
Leak current N-channel	I _{LEAKN}	—	—	10	μA	V _{sw} = 18 V
Maximum duty cycle	D _{MAX}	75	85	95	%	
[Overcurrent protection]						
Saw current limit	I _{sw}	2	3	—	A	*

2. Regulator controller

Parameter	Symbol	Limits			Unit	Conditions
		Min.	Typ.	Max.		
[Error amp]						
VDD voltage	VDD	2.4	2.5	2.6	V	
Maximum base current	I _{BMAX}	2	7	15	mA	
Line regulation	Reg _L	—	10	30	mV	V _{cc} = 4.5 V to 5.5 V
Load regulation	Reg _L	—	10	50	mV	I _o = 10 mA to 100 mA
[Under-voltage lockout protection]						
Off threshold voltage	V _{ROFF}	1.7	1.8	1.9	V	
On threshold voltage	V _{RON}	1.6	1.7	1.8	V	

○ This product is not designed for protection against radioactive rays.

* Design guarantee (No total shipment inspection is made.)

3. Charge pump

Parameter	Symbol	Limits			Unit	Conditions
		Min.	Typ.	Max.		
[Error amp]						
Input bias current 2	I_{FB2}	—	0.1	0.5	μA	
Input bias current 3	I_{FB3}	—	0.1	0.5	μA	
Feedback voltage 2	V_{FB2}	1.183	1.240	1.307	V	
Feedback voltage 3	V_{FB3}	0.15	0.2	0.25	V	
[Delay start block]						
Source current	I_{DSO}	3	5	7	μA	VDLS = 0.5V
Sinking current	I_{DSI}	0.1	0.5	1.0	mA	VDLS = 0.5V
Startup voltage	V_{ST}	0.45	0.60	0.75	V	
[Switch]						
ON resistance N-channel	R_{ON_NC}	0.5	2	4	Ω	$I_o = 10 \text{ mA}^*$
ON resistance P-channel	R_{ON_PC}	0.5	4	8	Ω	$I_o = -10 \text{ mA}^*$
[Diode]						
Voltage of diode	V_f	600	710	800	mV	$I_o = 10 \text{ mA}$
[Gate shading block]						
ON resistance N-channel	R_{ON_NGS}	2	10	20	Ω	$I_o = 10 \text{ mA}^*$
ON resistance P-channel	R_{ON_PGS}	2	10	20	Ω	$I_o = -10 \text{ mA}^*$
Leak current N-channel	I_{LEAK_NGS}	—	—	10	μA	
Leak current P-channel	I_{LEAK_PGS}	—	—	10	μA	
High voltage	IGH	$V_{DD} \times 0.7$	VDD	—	V	
Low voltage	IGL	—	0	$V_{DD} \times 0.3$	V	
Input current	IIG	8	16.5	30	μA	$I_G = 3.3 \text{ V}$

○ This product is not designed for protection against radioactive rays.

* Design guarantee (No total shipment inspection is made.)

4. Overall

Parameter	Symbol	Limits			Unit	Conditions
		Min.	Typ.	Max.		
[Reference block]						
Reference voltage	V_{REF}	1.215	1.240	1.265	V	
Drive current	I_{REF}	—	23	—	mA	$V_{REF} = 0\text{ V}$
Load regulation	ΔV	—	1	10	mV	$I_{REF} = -1\text{ mA}$
[Oscillator]						
Oscillating frequency	F_{osc}	0.94	1.1	1.265	MHz	
[Oscillator]						
DET 1 On threshold voltage	V_{DON1}	1.7	1.8	1.9	V	
DET 1 Off threshold voltage	V_{DOFF1}	1.6	1.7	1.8	V	
DET 2 On threshold voltage	V_{DON2}	1.02	1.12	1.22	V	
DET 2 Off threshold voltage	V_{DOFF2}	0.90	1.00	1.10	V	
DET 3 On threshold voltage	V_{DON3}	0.25	0.30	0.35	V	
DET 3 Off threshold voltage	V_{DOFF3}	0.35	0.41	0.47	V	
DET 4 On threshold voltage	V_{DON4}	1.02	1.12	1.22	V	
DET 4 Off threshold voltage	V_{DOFF4}	0.90	1.00	1.10	V	
[Device]						
Average circuit current	I_{CC}	0.5	2	5	mA	No switching

○ This product is not designed for protection against radioactive rays.

●Reference Data (Unless otherwise specified, Ta = 25°C)

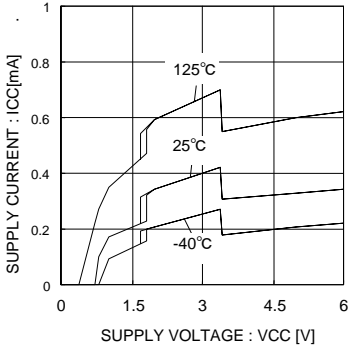

Fig. 1 Total Supply Current 1

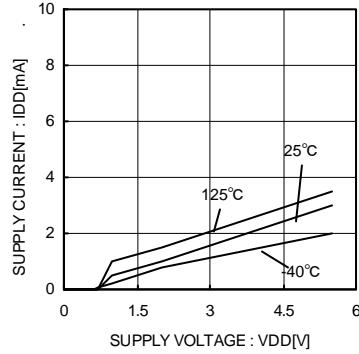

Fig. 2 Total Supply Current 2

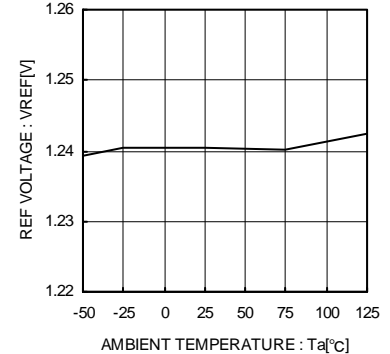

Fig. 3 Internal Reference Temperature

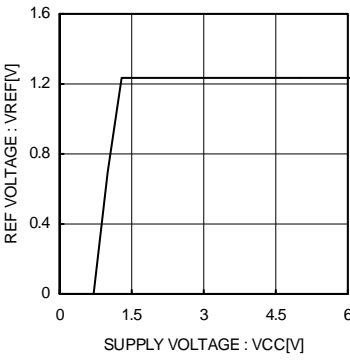

Fig. 4 Internal Reference Line Regulation

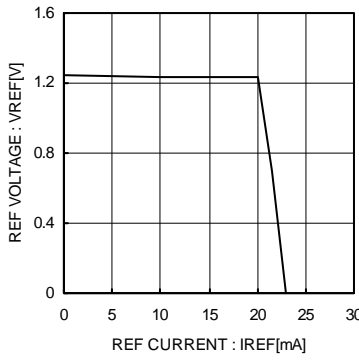

Fig. 5 Internal Reference Load Regulation

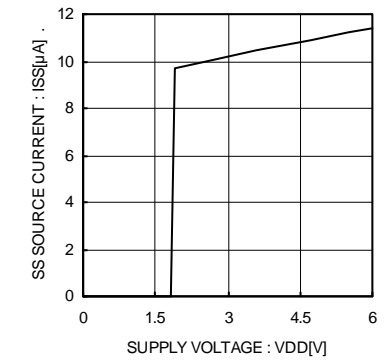

Fig. 6 SS Source Current

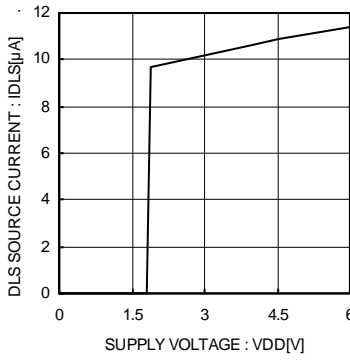

Fig. 7 DLS Source Current

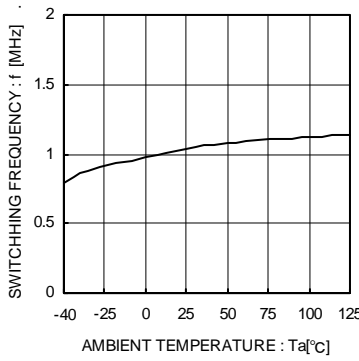

Fig. 8 Switching Frequency Temperature

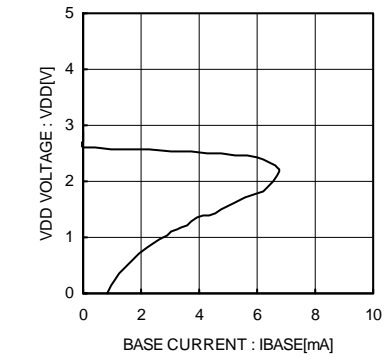

Fig. 9 REG Current Capacity Temperature

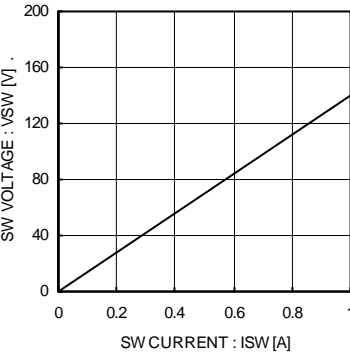

Fig. 10 SW On Resistance

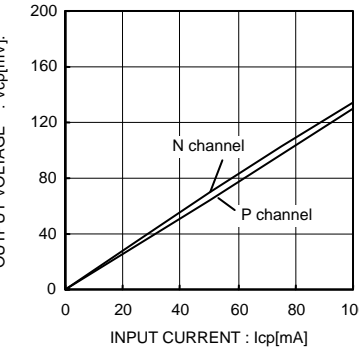

Fig. 11 Charge Pump On Voltage

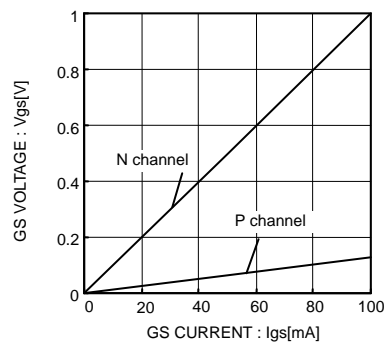

Fig. 12 Gate Shading On Voltage

●Reference Data (Unless otherwise specified, Ta = 25°C)

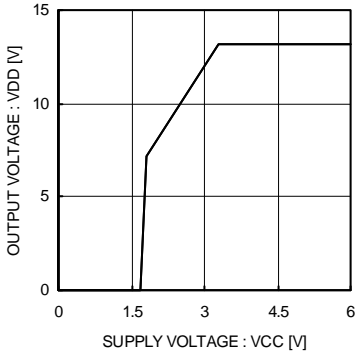

Fig. 13 Vo1 Line Regulation

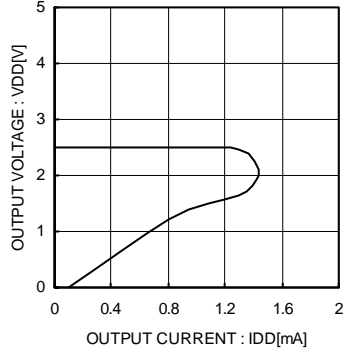

Fig. 14 VDD Load Regulation

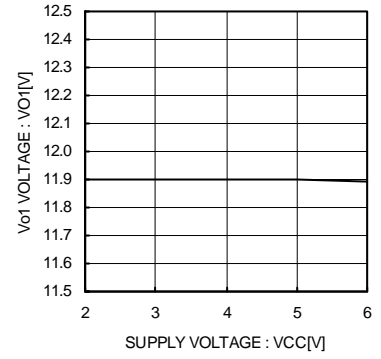

Fig. 15 Vo1 Line Regulation

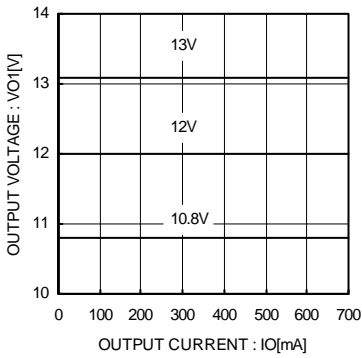

Fig. 16 Vo1 Load Regulation

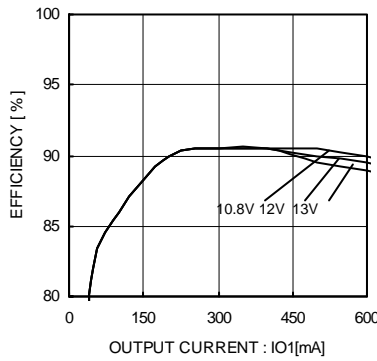

Fig. 17 Efficiency vs Output Current

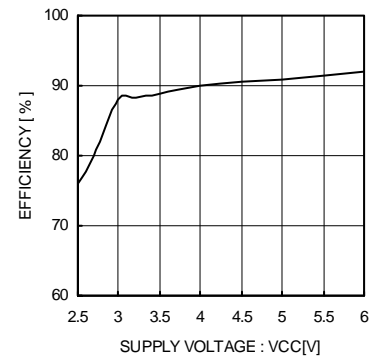

Fig. 18 Efficiency vs Power Supply Voltage

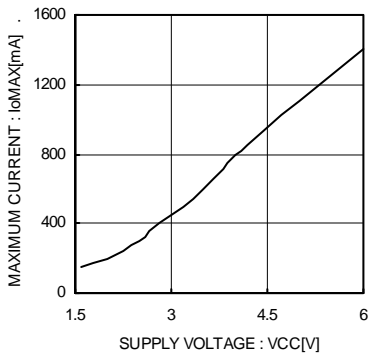

Fig. 19 Power Supply Voltage vs Max. Output Current Capacity

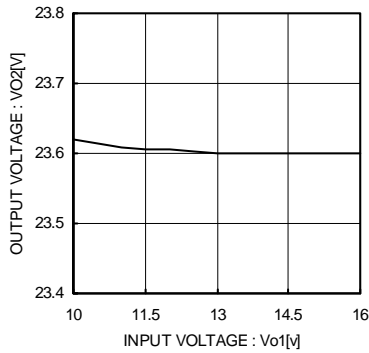

Fig. 20 Vo2 Line Regulation

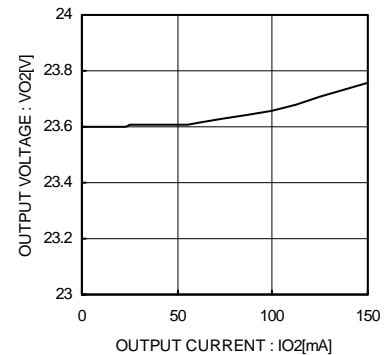

Fig. 21 Vo2 Load Regulation

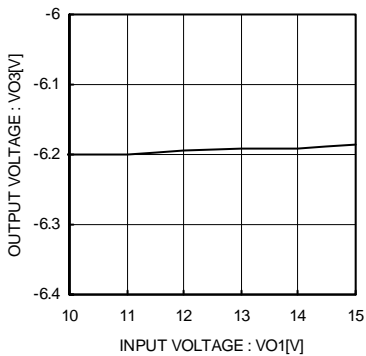

Fig. 22 Negative-side Charge Pump Line Regulation

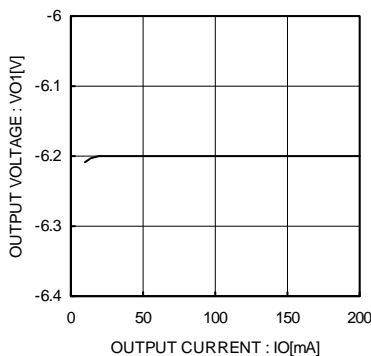

Fig. 23 Negative-side Charge Pump Load Regulation

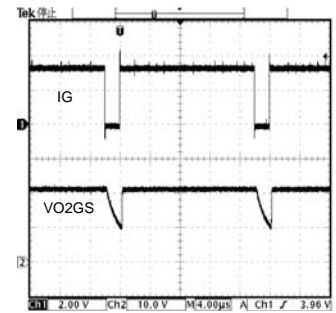

Fig. 24 Gate Shading Output Waveform

●Block Diagram

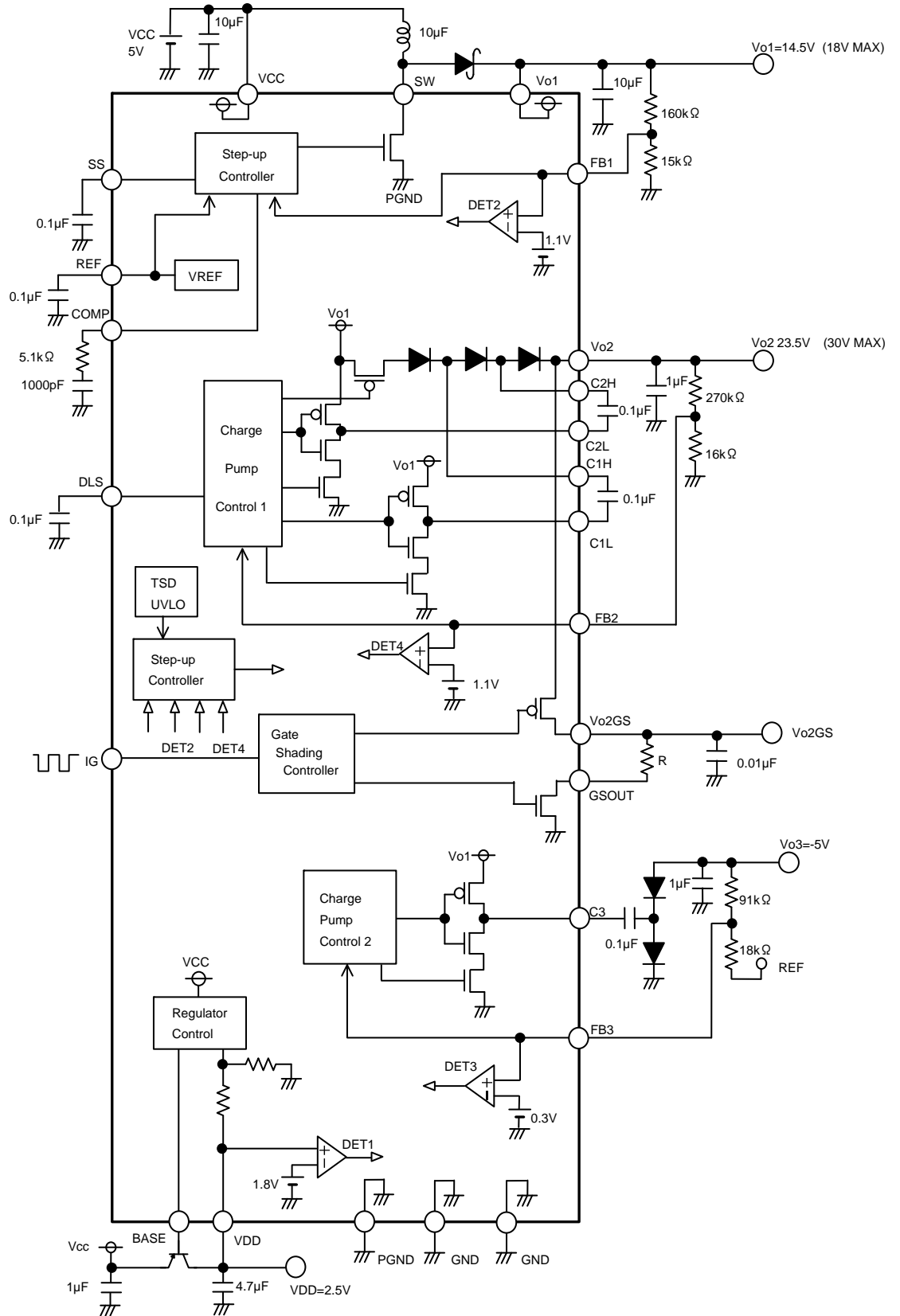
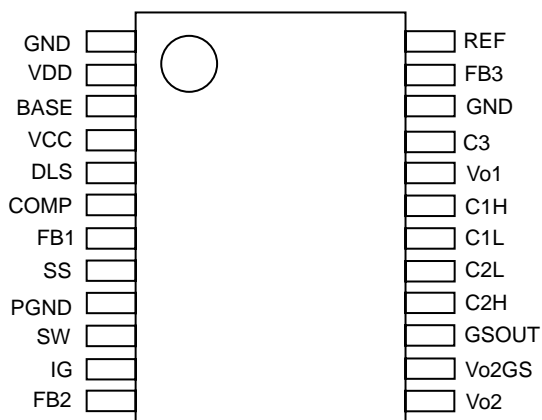

Fig. 25 Block Diagram

●Pin Assignments Diagram



Pin Arrangements

●Pin Assignments and Function

PIN NO.	Pin name	Function	PIN NO.	Pin name	Function
1	GND	Ground pin	13	Vo2	Positive-side charge pump output
2	VDD	LDO feedback input pin	14	Vo2GS	Gate shading source output pin
3	BASE	LDO base drive output pin	15	GSOUT	Gate shading sink output pin
4	VCC	Power supply input pin	16	C2H	Flying capacitor connection pin
5	DLS	Capacity connection pin for delay start	17	C2L	Flying capacitor connection pin
6	COMP	DC/DC difference amplifier output	18	C1L	Flying capacitor connection pin
7	FB1	DC/DC feedback input	19	C1H	Flying capacitor connection pin
8	SS	Soft start capacitor connection pin	20	Vo1	Negative-side charge pump power supply input pin
9	PGND	Ground pin	21	C3	Negative-side charge pump driver output
10	SW	Switch output	22	GND	Ground pin
11	IG	Gate shading input	23	FB3	Negative-side charge pump feedback input
12	FB2	Positive-side charge pump feedback input	24	REF	Internal standard output pin

●Block Function

- Step-up Controller
A controller circuit for DC/DC boosting.
The switching duty is controlled so that the feedback voltage FB1 is set to 1.24 V (typ.). A soft start operates at the time of starting. Therefore, the switching duty is controlled by the SS pin voltage.
- Charge Pump Control 1
A controller circuit for the positive-side charge pump.
The switching amplitude is controlled so that the feedback voltage FB2 will be set to 1.24 V (typ.). The start delay time can be set in the DLS terminal at the time of starting. When the DLS voltage reaches 0.6 V (Typ.), switching waves will be output from the C1L and C2L pins.
- Charge Pump Control 2
A controller circuit for the negative-side charge pump.
The switching amplitude is controlled so that the feedback voltage FB2 will be set to 0.6 V (Typ.).
- Gate Shading Controller
A controller circuit of gate shading.
The Vo2GS and GSOUT are in on/off control according to IG pin input.
- Regulator Control
A regulator controller circuit for VDD voltage generation.
The base pin current is controlled so that V_{DD} voltage will be set to 2.5 V (typ.).
- DET 1 to DET 4
A detection circuit of each output voltage. This detected signal is used for the starting sequential circuit.
- Start-up Controller
A control circuit for the starting sequence.
Controls to start in order of V_{CC} → VDD → Vo1 → Vo3 → Vo2.
- VREF
A block that generates internal reference voltage. 1.24V (Typ.) is output.
- TSD/UVLO
Thermal shutdown/Under-voltage lockout protection/circuit blocks.
The thermal shutdown circuit is shut down at an IC internal temperature of 175°C and reset at 160°C. The under-voltage lockout protection circuit shuts down the IC when the V_{CC} is 1.8 V (typ.) or below.
- Starting sequence
For malfunction prevention, starting logic control operates so that each output will rise in order of V_{CC} → VDD → Vo1 → Vo3 → Vo2.
As shown below, detectors DET1 to DET3 detect that the output on the detection side has reached 90% (typ.) of the set voltage, and starts the next block.

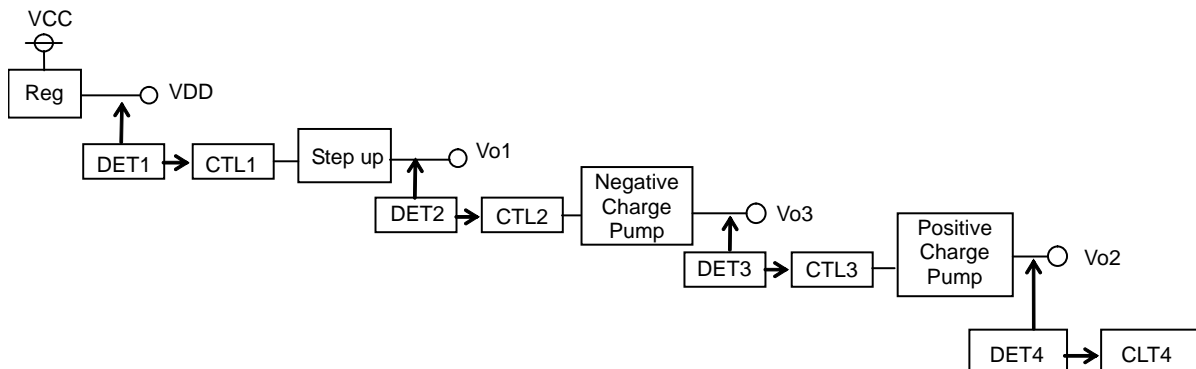

Starting sequence model

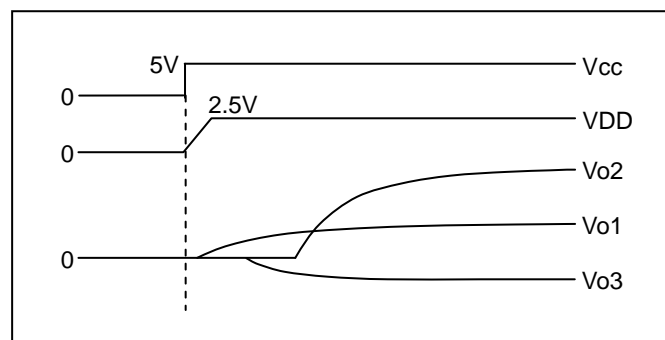

Fig. 26 Starting Timing Chart

●Selecting Application Components

(1) Setting the Output L Constant

The coil to use for output is decided by the rating current I_{LR} and input current maximum value I_{INMAX} of the coil.

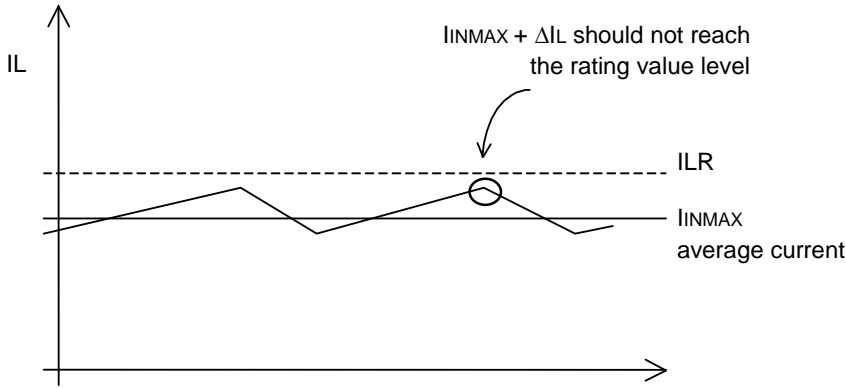

Fig. 27 Coil Current Waveform

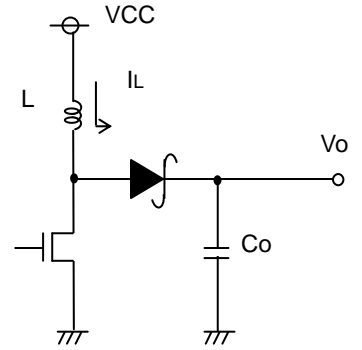

Fig. 28 Output Application Circuit Diagram

Adjust so that $I_{INMAX} + \Delta I_L$ do not reach the rating current value I_{LR} . At this time, ΔI_L can be obtained by the following equation.

$$\Delta I_L = \frac{1}{L} V_{CC} \times \frac{V_o - V_{CC}}{V_{CC}} \times \frac{1}{f} \text{ [A]} \quad \text{Here, } f \text{ is the switching frequency.}$$

Set with sufficient margin because the coil value may have the dispersion of $\pm 30\%$. If the coil current exceeds the rating current I_{LR} of the coil, it may damage the IC internal element.

BD8163EFV uses the current mode DC/DC converter control and has the optimized design at the coil value. A coil inductance (L) of 4.7 μH to 15 μH is recommended from viewpoints of electric power efficiency, response, and stability.

(2) Output Capacity Settings

For the capacitor to use for the output, select the capacitor which has the larger value in the ripple voltage V_{PP} allowance value and the drop voltage allowance value at the time of sudden load change. Output ripple voltage is decided by the following equation.

$$\Delta V_{PP} = I_{LMAX} \times R_{ESR} + \frac{1}{f C_o} \times \frac{V_{CC}}{V_o} \times \left(I_{LMAX} - \frac{\Delta I_L}{2} \right) \text{ [V]} \quad \text{Here, } f \text{ is the switching frequency.}$$

Perform setting so that the voltage is within the allowable ripple voltage range.

For the drop voltage during sudden load change; V_{DR} , please perform the rough calculation by the following equation.

$$V_{DR} = \frac{\Delta I}{C_o} \times 10 \mu\text{s} \text{ [V]}$$

However, 10 μs is the rough calculation value of the DC/DC response speed. Please set the capacitance considering the sufficient margin so that these two values are within the standard value range.

(3) Selecting the Input Capacitor

Since the peak current flows between the input and output at the DC/DC converter, a capacitor is required to install at the input side. For the reason, the low ESR capacitor is recommended as an input capacitor which has the value more than 10 μF and less than 100 $\text{m}\Omega$. If a capacitor out of this range is selected, the excessive ripple voltage is superposed on the input voltage; accordingly it may cause the malfunction of IC.

However these conditions may vary according to the load current, input voltage, output voltage, inductance and switching frequency. Be sure to perform the margin check using the actual product.

(4) Setting RC, CC of the Phase Compensation Circuit

In the current mode control, since the coil current is controlled, a pole (phase lag) made by the CR filter composed of the output capacitor and load resistor will be created in the low frequency range, and a zero (phase lead) by the output capacitor and ESR of capacitor will be created in the high frequency range. In this case, to cancel the pole of the power amplifier, it is easy to compensate by adding the zero point with C_c and R_c to the output from the error amp as shown in the illustration.

Open loop gain characteristics

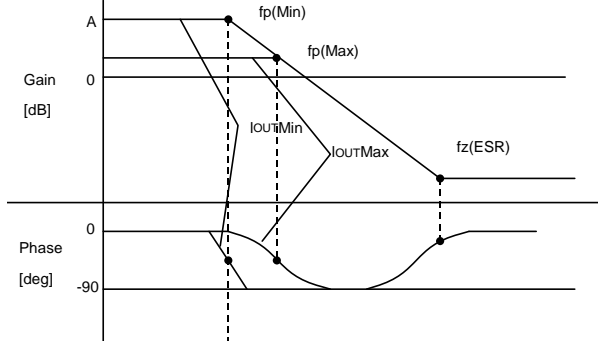

Error amp phase compensation characteristics

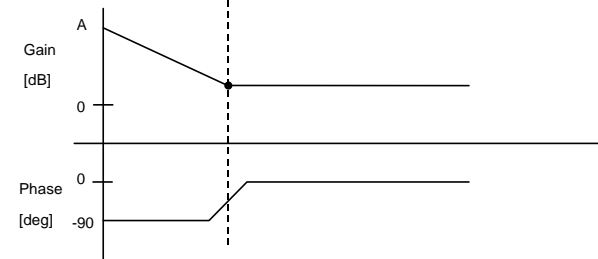

$$F_p = \frac{1}{2 \pi \times R_o \times C_o} \text{ [Hz]}$$

$$f_z(\text{ESR}) = \frac{1}{2 \pi \times \text{ESR} \times C_o} \text{ [Hz]}$$

Pole at the power amplification stage

When the output current reduces, the load resistance R_o increases and the pole frequency lowers.

$$f_p(\text{Min}) = \frac{1}{2 \pi \times R_{o\text{Max}} \times C_o} \text{ [Hz]} \leftarrow \text{at light load}$$

$$f_z(\text{Max}) = \frac{1}{2 \pi \times R_{o\text{Min}} \times C_o} \text{ [Hz]} \leftarrow \text{at heavy load}$$

Zero at the power amplification stage

When the output capacitor is set larger, the pole frequency lowers but the zero frequency will not change. (This is because the capacitor ESR becomes 1/2 when the capacitor becomes 2 times.)

$$f_p(\text{Amp.}) = \frac{1}{2 \pi \times R_c \times C_c} \text{ [Hz]}$$

Fig. 29 Gain vs Phase

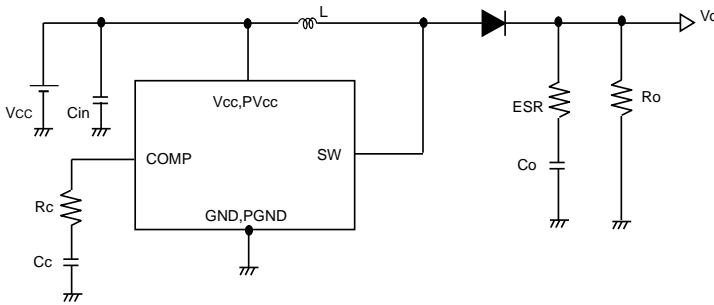

Fig. 30 Application Circuit Diagram

It is possible to realize the stable feedback loop by canceling the pole $f_p(\text{Min.})$, which is created by the output capacitor and load resistor, with CR zero compensation of the error amp as shown below.

$$f_z(\text{Amp.}) = f_p(\text{Min.})$$

$$\longrightarrow \frac{1}{2 \pi \times R_c \times C_c} = \frac{1}{2 \pi \times R_{o\text{max}} \times C_o} \text{ [Hz]}$$

(5) Regulator Controller Settings

The IC incorporates a 2.5 V regulator controller, and a regulator can be formed by using an external PNP transistor. Design the current capability of the regulator with a margin according to the following formula.

$$I_{OMAX} = 7mA \times h_{fe} \quad [A]$$

The h_{fe} is the current gain of the external PNP transistor.
7 mA is the sinking current of the internal transistor.

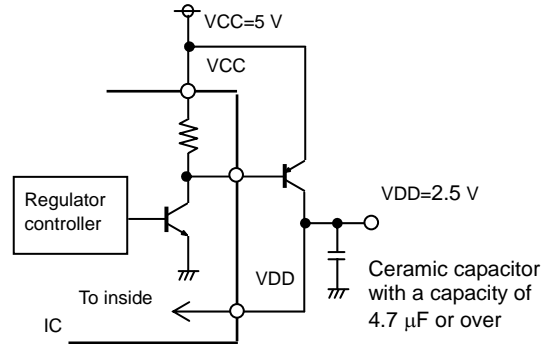

Fig.31

It is not necessary to use the regulator if the input voltage is 2.5 V. In that case, input 2.5 V to both VCC and VDD.

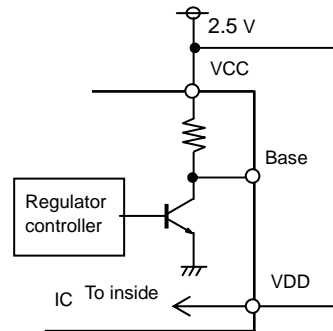

Fig.32

When incorporating a regulator into the external transistor, input the output voltage into the regulator.

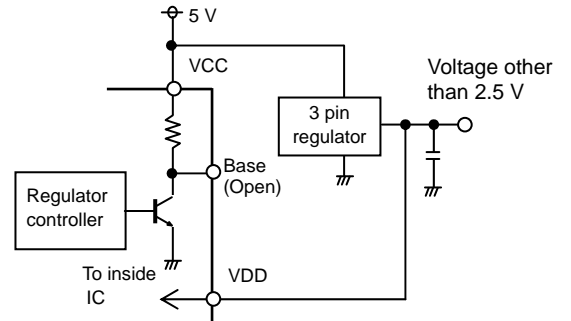

Fig.33

(6) Setting the Soft Start Time

Soft start is required to prevent the coil current at the time of start from increasing and the overshoot of the output voltage at the starting time. The relation between the capacity and soft start time is shown in the following figure. Refer to the figure and set capacity C1. Soft start is required to prevent the coil current at the time of start from increasing and the overshoot of the output voltage at the starting time. Fig. 34 shows the relation between the capacitance and soft start time. Please refer to it to set the capacitance.

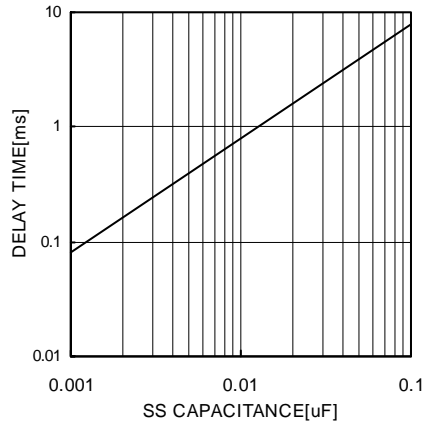

Fig. 34 SS Pin Capacitance vs Delay Time

As the capacitance, 0.001 μF to 0.1 μF is recommended. If the capacitance is set lower than 0.001 μF, the overshooting may occur on the output voltage. If the capacitance is set larger than 0.1 μF, the excessive back current flow may occur in the internal parasitic elements when the power is turned OFF and it may damage IC. When there is the activation relation (sequences) with other power supplies, be sure to use the high accuracy product (such as X5R). Soft start time may vary according to the input voltage, loads, coils and output capacity. Be sure to verify the operation using the actual product.

(7) Design of the Feedback Resistor Constant

Refer to the following equation to set the feedback resistor. As the setting range, 10 kΩ to 330 kΩ is recommended. If the resistor is set lower than a 10 kΩ, it causes the reduction of power efficiency. If it is set more than 330 kΩ, the offset voltage becomes larger by the input bias current 0.4 μA(Typ.) in the internal error amplifier.

$$V_o = \frac{R8 + R9}{R9} \times 1.24 \quad [V]$$

Sep-up

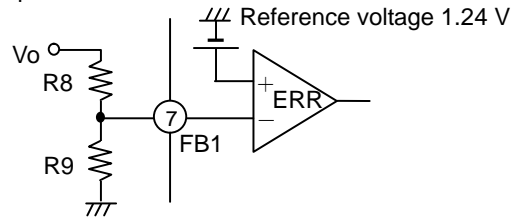

Fig. 35

(8) Positive-side Charge Pump Settings

The IC incorporates a charge pump controller, thus making it possible to generate stable gate voltage.

The output voltage is determined by the following formula. As the setting range, 10 kΩ to 330 kΩ is recommended. If the resistor is set lower than a 10kΩ, it causes the reduction of power efficiency. If it is set more than 330 kΩ, the offset voltage becomes larger by the input bias current 0.4 μA (Typ.) in the internal error amp.

$$V_o = \frac{R8 + R9}{R9} \times 1.24 \quad [V]$$

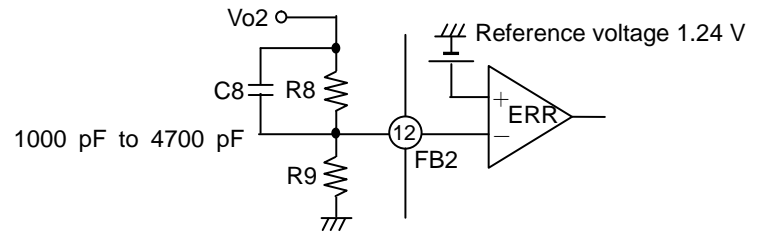

Fig. 36

In order to prevent output voltage overshooting, add capacitor C8 in parallel with R8. The recommended capacitance is 1000 pF to 4700 pF. If a capacitor outside this range is inserted, the output voltage may oscillate.

By connecting capacitance to the DLS, a rising delay time can be set for the positive-side charge pump. The delay time is determined by the following formula.

- Delay time of charge pump block t_{DELAY}

$$t_{\text{DELAY}} = (C_{\text{DLS}} \times 0.6) / 5 \mu\text{A} \quad [\text{s}]$$

where, C_{DLS} is the external capacitance.

(9) Negative-side Charge Pump Settings

This IC incorporates a charge pump controller for negative voltage, thus making it possible to generate stable gate voltage. The output voltage is determined by the following formula. As the setting range, 10 kΩ to 330 kΩ is recommended. If the resistor is set lower than a 10 kΩ, it causes the reduction of power efficiency. If it is set more than 330 kΩ, the offset voltage becomes larger by the input bias current 0.4 μA (Typ.) in the internal error amp.

$$V_{o3} = -\frac{R6}{R7} \times 1.04 + 0.2 \text{ V} \quad [V]$$

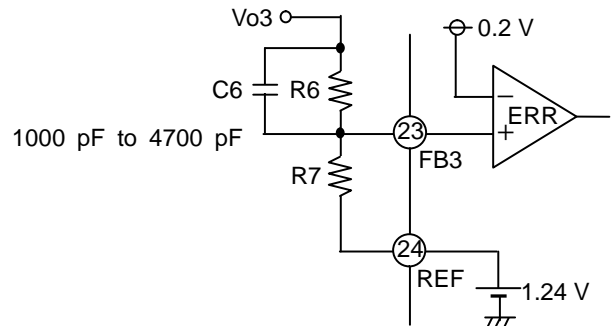

Fig.37

The delay time is internally fixed at 200 μs.

In order to prevent output voltage overshooting, insert capacitor C6 in parallel with R6. The recommended capacitance is 1000 pF to 4700 pF. If a capacitor outside this range is inserted, the output voltage may oscillate.

●Gate Shading Setting Method

The IG input signal allows the high-level and low-level control of the positive-side gate voltage. The slope of output can be set by the external RC. The recommended resistance set value is 200 Ω to 5.1 kΩ and the recommended capacitor set value is 0.001 μF to 0.1 μF. The aggravation of efficiency may be caused if settings outside this range are made. Determine ΔV by referring to the following value. The following calculation formula is used for ΔV.

$$\Delta V = V_{o2GS} \left(1 - \exp\left(-\frac{t_{WL}}{CR}\right) \right) \quad [V]$$

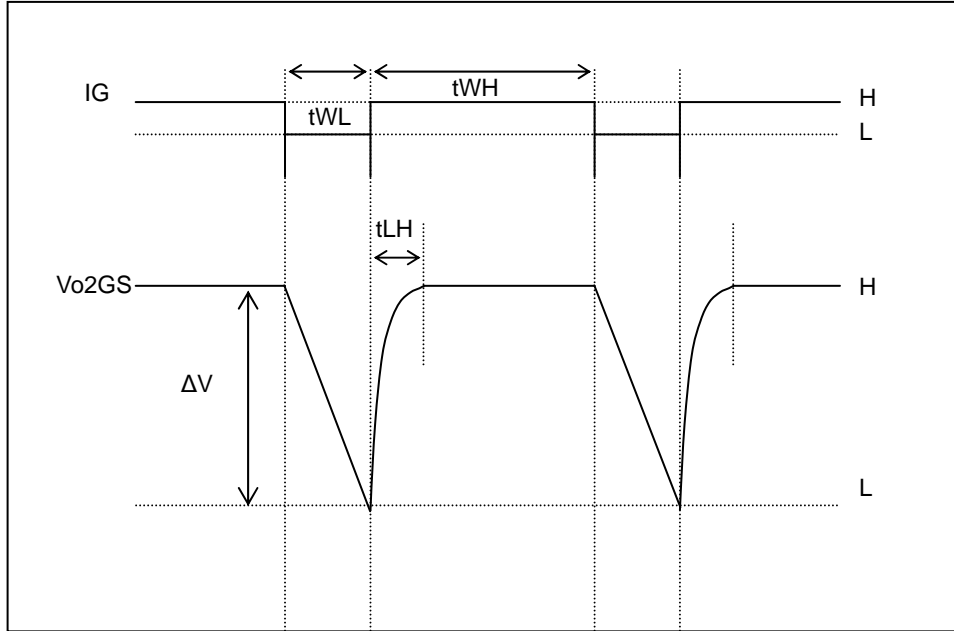

Fig. 38

TIMING STANDARD VALUE

Parameter	Symbol	Limits			Unit	Condition
		Min.	Typ.	Max.		
IG "L" Time	tWL	1	2	-	μs	-
IG "H" Time	tWH	1	18	-	μs	-
Vo2GS "H" to "L" Voltage difference	ΔV	-	10	-	V	TWL = 2 μs, R = 500 Ω *
Vo2GS "L" to "H" Time	tLH	-	0.1	-	μs	ΔV = 10 V *

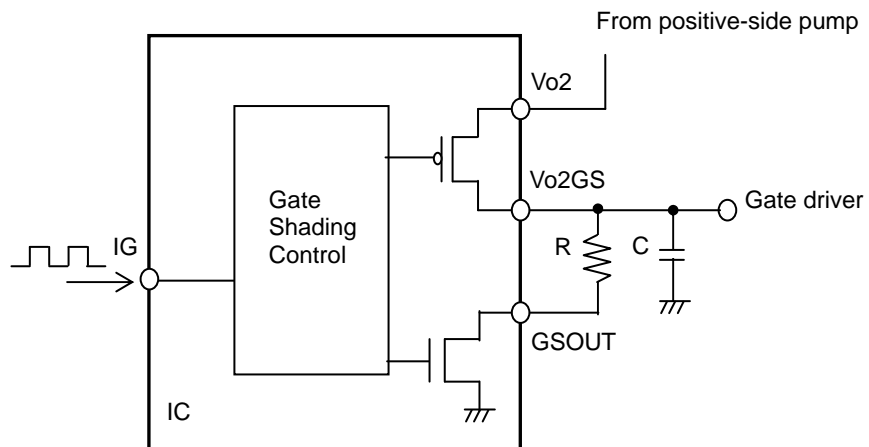

Fig. 39

●Application Examples

Although we are confident that the application circuit diagram reflects the best possible recommendations, be sure to verify circuit characteristics for your particular application. When a circuit is used modifying the externally connected circuit constant, be sure to decide allowing sufficient margins considering the dispersion of values by external parts as well as our IC including not only the static but also the transient characteristic. For the patent, we have not acquired the sufficient confirmation. Please acknowledge the status.

(a) Input voltage
5 V

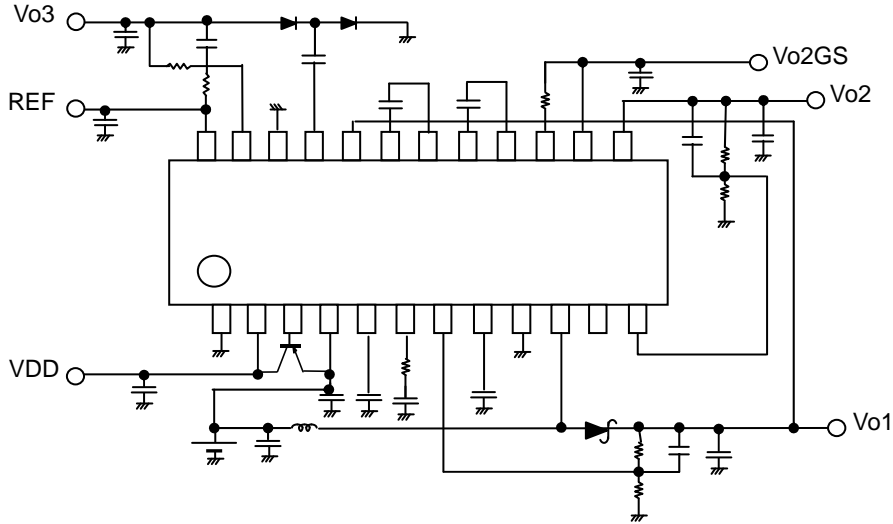

Fig. 40

(b) Input voltage
2.5 V

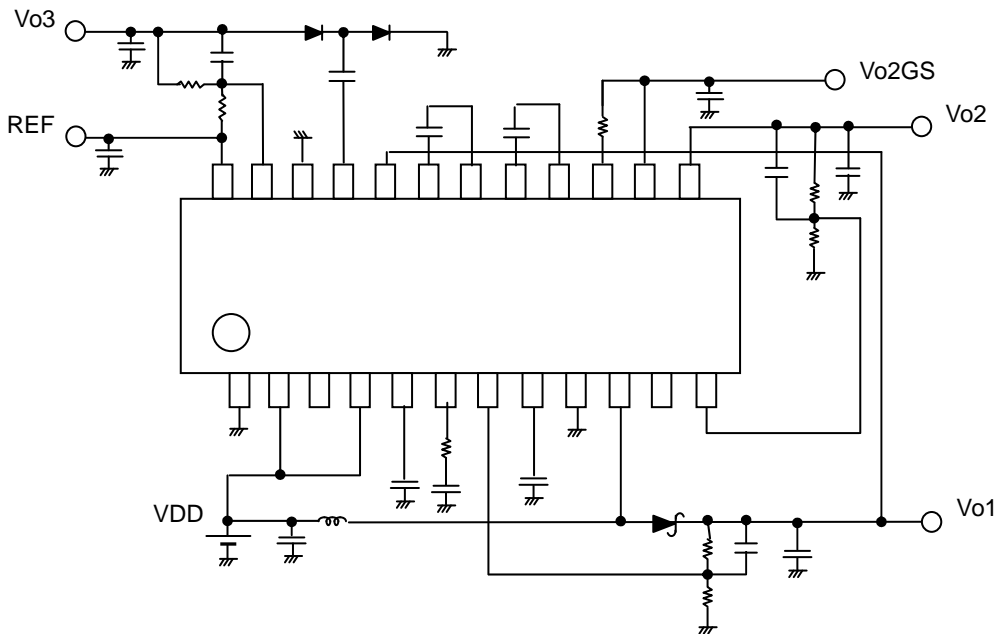

Fig. 41

(c) When Inserting PMOS Switch

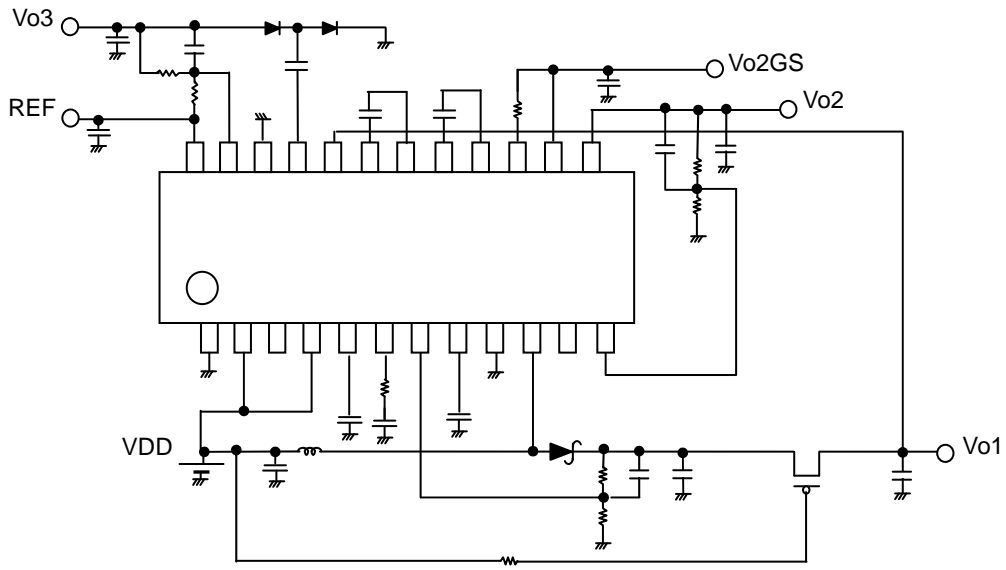

Fig. 42

● I/O Equivalent Circuits

<p>2.VDD</p> 	<p>3.BASE</p> 	<p>5.DLS,8.SS</p> 
<p>6.COMP</p> 	<p>7.FB1,12.FB2</p> 	<p>10.SW</p> 
<p>11.IG</p> 	<p>13.Vo2</p> 	<p>14.Vo2GS</p> 
<p>15.GSOUT</p> 	<p>16.C2H,19.C1H</p> 	<p>17.C2L,18.C1L,21.C3</p> 
<p>23.FB3</p> 	<p>24.REF</p> 	

Fig. 43

● Power Dissipation Reduction

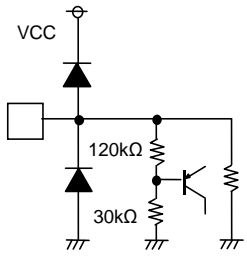
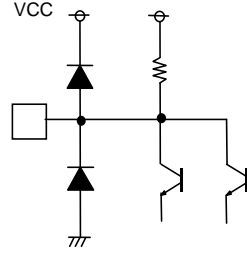
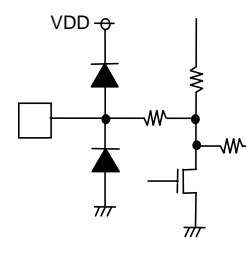
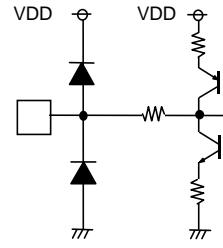
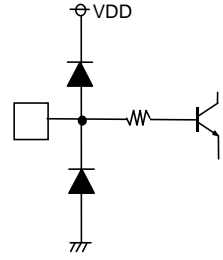
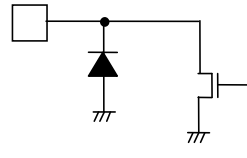
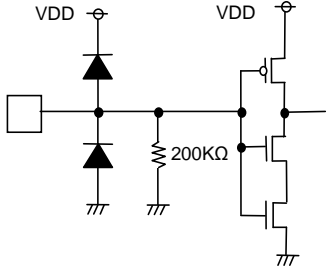
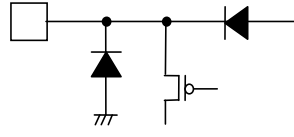
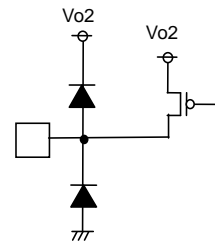
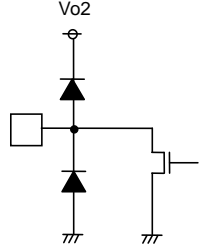
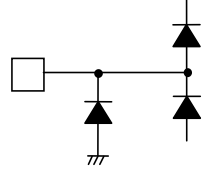
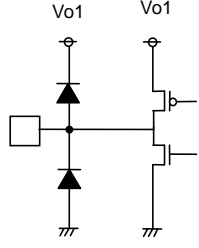
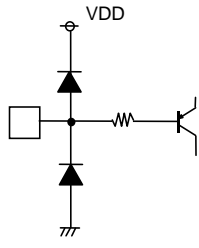
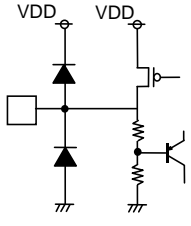
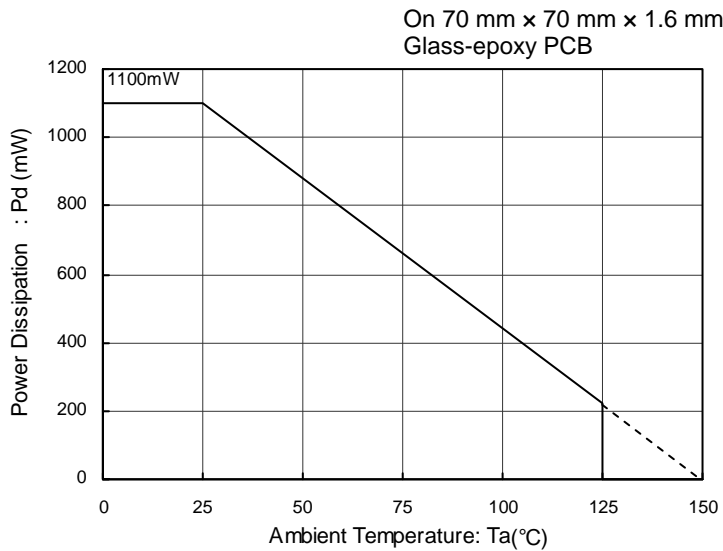

Fig.44

● Notes for use

- 1) Absolute maximum ratings
Use of the IC in excess of absolute maximum ratings such as the applied voltage or operating temperature range may result in IC damage. Assumptions should not be made regarding the state of the IC (short mode or open mode) when such damage is suffered. A physical safety measure such as a fuse should be implemented when use of the IC in a special mode where the absolute maximum ratings may be exceeded is anticipated.
- 2) GND potential
Ensure a minimum GND pin potential in all operating conditions.
- 3) Setting of heat
Use a thermal design that allows for a sufficient margin in light of the power dissipation (Pd) in actual operating conditions.
- 4) Pin short and mistake fitting
Use caution when orienting and positioning the IC for mounting on printed circuit boards. Improper mounting may result in damage to the IC. Shorts between output pins or between output pins and the power supply and GND pins caused by the presence of a foreign object may result in damage to the IC.
- 5) Actions in strong magnetic field
Use caution when using the IC in the presence of a strong magnetic field as doing so may cause the IC to malfunction.
- 6) Testing on application boards
When testing the IC on an application board, connecting a capacitor to a pin with low impedance subjects the IC to stress. Always discharge capacitors after each process or step. Ground the IC during assembly steps as an antistatic measure, and use similar caution when transporting or storing the IC. Always turn the IC's power supply off before connecting it to or removing it from a jig or fixture during the inspection process.
- 7) Ground wiring patterns
When using both small signal and large current GND patterns, it is recommended to isolate the two ground patterns, placing a single ground point at the application's reference point so that the pattern wiring resistance and voltage variations caused by large currents do not cause variations in the small signal ground voltage. Be careful not to change the GND wiring patterns of any external components.

- 8) This monolithic IC contains P+ isolation and P substrate layers between adjacent elements in order to keep them isolated. P/N junctions are formed at the intersection of these P layers with the N layers of other elements to create a variety of parasitic elements. For example, when the resistors and transistors are connected to the pins as shown in Fig.45, a parasitic diode or a transistor operates by inverting the pin voltage and GND voltage. The formation of parasitic elements as a result of the relationships of the potentials of different pins is an inevitable result of the IC's architecture. The operation of parasitic elements can cause interference with circuit operation as well as IC malfunction and damage. For these reasons, it is necessary to use caution so that the IC is not used in a way that will trigger the operation of parasitic elements, such as the application of voltages lower than the GND (P board) voltage to input and output pins.

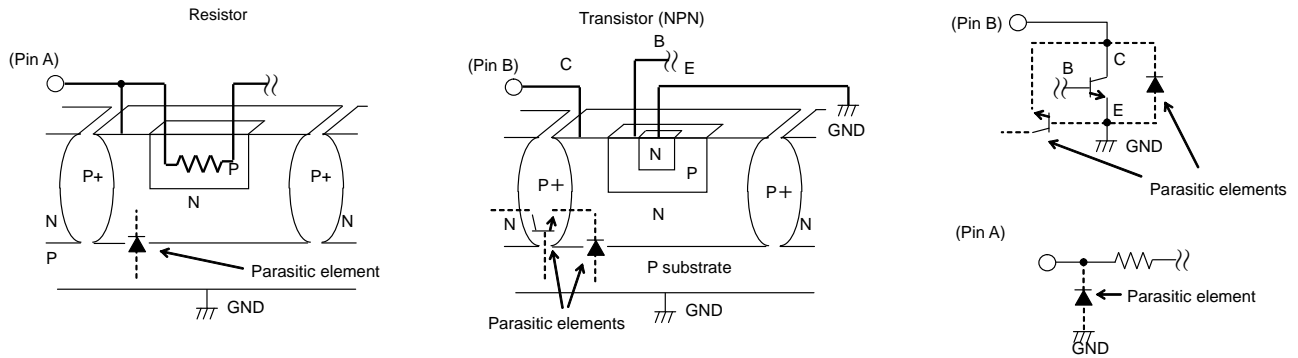

Fig.45 Example of a Simple Monolithic IC Architecture

9) Overcurrent protection circuits

An overcurrent protection circuit designed according to the output current is incorporated for the prevention of IC destruction that may result in the event of load shorting. This protection circuit is effective in preventing damage due to sudden and unexpected accidents. However, the IC should not be used in applications characterized by the continuous operation or transitioning of the protection circuits. At the time of thermal designing, keep in mind that the current capability has negative characteristics to temperatures.

10) Thermal shutdown circuit

This IC incorporates a built-in thermal shutdown circuit for the protection from thermal destruction. The IC should be used within the specified power dissipation range. However, in the event that the IC continues to be operated in excess of its power dissipation limits, the attendant rise in the chip's temperature T_j will trigger the thermal shutdown circuit to turn off all output power elements. The circuit automatically resets once the chip's temperature T_j drops.

Operation of the thermal shutdown circuit presumes that the IC's absolute maximum ratings have been exceeded. Application designs should never make use of the thermal shutdown circuit.

11) Testing on application boards

At the time of inspection of the installation boards, when the capacitor is connected to the pin with low impedance, be sure to discharge electricity per process because it may load stresses to the IC. Always turn the IC's power supply off before connecting it to or removing it from a jig or fixture during the inspection process. Ground the IC during assembly steps as an antistatic measure, and use similar caution when transporting or storing the IC.

●Ordering part number

B	D
---	---

Part No.

8	1	6	3
---	---	---	---

Part No.

E	F	V
---	---	---

Package
EFV: HTSSOP-B24

E	2
---	---

Packaging and forming specification
E2: Embossed tape and reel

HTSSOP-B24

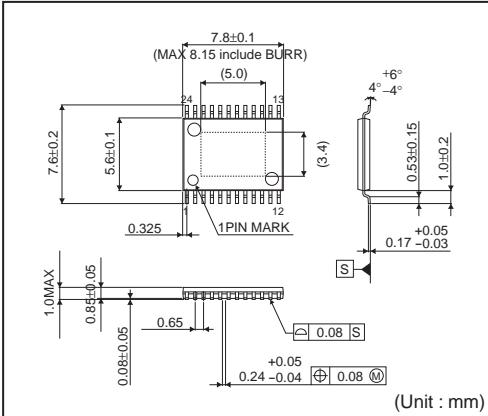

<Tape and Reel information>

Tape	Embossed carrier tape (with dry pack)
Quantity	2000pcs
Direction of feed	E2 (The direction is the 1pin of product is at the upper left when you hold reel on the left hand and you pull out the tape on the right hand)

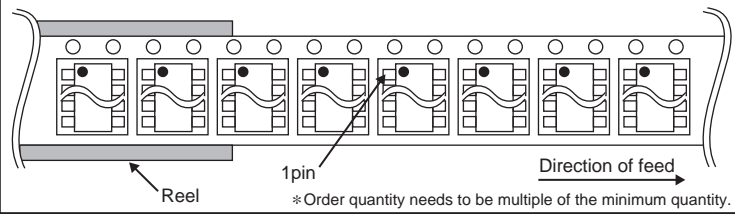

Notice

Precaution on using ROHM Products

- Our Products are designed and manufactured for application in ordinary electronic equipments (such as AV equipment, OA equipment, telecommunication equipment, home electronic appliances, amusement equipment, etc.). If you intend to use our Products in devices requiring extremely high reliability (such as medical equipment ^(Note 1), transport equipment, traffic equipment, aircraft/spacecraft, nuclear power controllers, fuel controllers, car equipment including car accessories, safety devices, etc.) and whose malfunction or failure may cause loss of human life, bodily injury or serious damage to property ("Specific Applications"), please consult with the ROHM sales representative in advance. Unless otherwise agreed in writing by ROHM in advance, ROHM shall not be in any way responsible or liable for any damages, expenses or losses incurred by you or third parties arising from the use of any ROHM's Products for Specific Applications.

(Note1) Medical Equipment Classification of the Specific Applications

JAPAN	USA	EU	CHINA
CLASS III	CLASS III	CLASS II b	CLASS III
CLASS IV		CLASS III	

- ROHM designs and manufactures its Products subject to strict quality control system. However, semiconductor products can fail or malfunction at a certain rate. Please be sure to implement, at your own responsibilities, adequate safety measures including but not limited to fail-safe design against the physical injury, damage to any property, which a failure or malfunction of our Products may cause. The following are examples of safety measures:
 - Installation of protection circuits or other protective devices to improve system safety
 - Installation of redundant circuits to reduce the impact of single or multiple circuit failure
- Our Products are designed and manufactured for use under standard conditions and not under any special or extraordinary environments or conditions, as exemplified below. Accordingly, ROHM shall not be in any way responsible or liable for any damages, expenses or losses arising from the use of any ROHM's Products under any special or extraordinary environments or conditions. If you intend to use our Products under any special or extraordinary environments or conditions (as exemplified below), your independent verification and confirmation of product performance, reliability, etc. prior to use, must be necessary:
 - Use of our Products in any types of liquid, including water, oils, chemicals, and organic solvents
 - Use of our Products outdoors or in places where the Products are exposed to direct sunlight or dust
 - Use of our Products in places where the Products are exposed to sea wind or corrosive gases, including Cl₂, H₂S, NH₃, SO₂, and NO₂
 - Use of our Products in places where the Products are exposed to static electricity or electromagnetic waves
 - Use of our Products in proximity to heat-producing components, plastic cords, or other flammable items
 - Sealing or coating our Products with resin or other coating materials
 - Use of our Products without cleaning residue of flux (even if you use no-clean type fluxes, cleaning residue of flux is recommended); or Washing our Products by using water or water-soluble cleaning agents for cleaning residue after soldering
 - Use of the Products in places subject to dew condensation
- The Products are not subject to radiation-proof design.
- Please verify and confirm characteristics of the final or mounted products in using the Products.
- In particular, if a transient load (a large amount of load applied in a short period of time, such as pulse. is applied, confirmation of performance characteristics after on-board mounting is strongly recommended. Avoid applying power exceeding normal rated power; exceeding the power rating under steady-state loading condition may negatively affect product performance and reliability.
- De-rate Power Dissipation (Pd) depending on Ambient temperature (Ta). When used in sealed area, confirm the actual ambient temperature.
- Confirm that operation temperature is within the specified range described in the product specification.
- ROHM shall not be in any way responsible or liable for failure induced under deviant condition from what is defined in this document.

Precaution for Mounting / Circuit board design

- When a highly active halogenous (chlorine, bromine, etc.) flux is used, the residue of flux may negatively affect product performance and reliability.
- In principle, the reflow soldering method must be used; if flow soldering method is preferred, please consult with the ROHM representative in advance.

For details, please refer to ROHM Mounting specification

Precautions Regarding Application Examples and External Circuits

1. If change is made to the constant of an external circuit, please allow a sufficient margin considering variations of the characteristics of the Products and external components, including transient characteristics, as well as static characteristics.
2. You agree that application notes, reference designs, and associated data and information contained in this document are presented only as guidance for Products use. Therefore, in case you use such information, you are solely responsible for it and you must exercise your own independent verification and judgment in the use of such information contained in this document. ROHM shall not be in any way responsible or liable for any damages, expenses or losses incurred by you or third parties arising from the use of such information.

Precaution for Electrostatic

This Product is electrostatic sensitive product, which may be damaged due to electrostatic discharge. Please take proper caution in your manufacturing process and storage so that voltage exceeding the Products maximum rating will not be applied to Products. Please take special care under dry condition (e.g. Grounding of human body / equipment / solder iron, isolation from charged objects, setting of ionizer, friction prevention and temperature / humidity control).

Precaution for Storage / Transportation

1. Product performance and soldered connections may deteriorate if the Products are stored in the places where:
 - [a] the Products are exposed to sea winds or corrosive gases, including Cl₂, H₂S, NH₃, SO₂, and NO₂
 - [b] the temperature or humidity exceeds those recommended by ROHM
 - [c] the Products are exposed to direct sunshine or condensation
 - [d] the Products are exposed to high Electrostatic
2. Even under ROHM recommended storage condition, solderability of products out of recommended storage time period may be degraded. It is strongly recommended to confirm solderability before using Products of which storage time is exceeding the recommended storage time period.
3. Store / transport cartons in the correct direction, which is indicated on a carton with a symbol. Otherwise bent leads may occur due to excessive stress applied when dropping of a carton.
4. Use Products within the specified time after opening a humidity barrier bag. Baking is required before using Products of which storage time is exceeding the recommended storage time period.

Precaution for Product Label

QR code printed on ROHM Products label is for ROHM's internal use only.

Precaution for Disposition

When disposing Products please dispose them properly using an authorized industry waste company.

Precaution for Foreign Exchange and Foreign Trade act

Since our Products might fall under controlled goods prescribed by the applicable foreign exchange and foreign trade act, please consult with ROHM representative in case of export.

Precaution Regarding Intellectual Property Rights

1. All information and data including but not limited to application example contained in this document is for reference only. ROHM does not warrant that foregoing information or data will not infringe any intellectual property rights or any other rights of any third party regarding such information or data. ROHM shall not be in any way responsible or liable for infringement of any intellectual property rights or other damages arising from use of such information or data.:
2. No license, expressly or implied, is granted hereby under any intellectual property rights or other rights of ROHM or any third parties with respect to the information contained in this document.

Other Precaution

1. This document may not be reprinted or reproduced, in whole or in part, without prior written consent of ROHM.
2. The Products may not be disassembled, converted, modified, reproduced or otherwise changed without prior written consent of ROHM.
3. In no event shall you use in any way whatsoever the Products and the related technical information contained in the Products or this document for any military purposes, including but not limited to, the development of mass-destruction weapons.
4. The proper names of companies or products described in this document are trademarks or registered trademarks of ROHM, its affiliated companies or third parties.

General Precaution

1. Before you use our Products, you are requested to carefully read this document and fully understand its contents. ROHM shall not be in any way responsible or liable for failure, malfunction or accident arising from the use of any ROHM's Products against warning, caution or note contained in this document.
2. All information contained in this document is current as of the issuing date and subject to change without any prior notice. Before purchasing or using ROHM's Products, please confirm the latest information with a ROHM sales representative.
3. The information contained in this document is provided on an "as is" basis and ROHM does not warrant that all information contained in this document is accurate and/or error-free. ROHM shall not be in any way responsible or liable for any damages, expenses or losses incurred by you or third parties resulting from inaccuracy or errors of or concerning such information.