

Telegesis™	 SILICON LABS	TG-PM-0509-ETRX358x r8
ETRX358x and ETRX358xHR		Product Manual

Telegesis™ is a trademark of Silicon Laboratories Inc.

ETRX358x ZIGBEE® MODULES

PRODUCT MANUAL



Table of Contents

1	INTRODUCTION	5
1.1	Hardware Description	5
2	PRODUCT APPROVALS	6
2.1	FCC Approvals	6
2.1.1	FCC Labelling Requirements.....	7
2.2	IC (Industry Canada) Approvals.....	7
2.2.1	IC Labelling Requirements.....	8
2.3	European Certification (ETSI)	8
2.4	Declarations of Conformity.....	9
2.5	IEEE 802.15.4	9
2.6	The ZigBee Protocol	10
3	MODULE PINOUT	11
4	HARDWARE DESCRIPTION.....	13
4.1	Hardware Interface	13
5	FIRMWARE DESCRIPTION	14
5.1	Token Settings.....	15
5.2	Custom Firmware	15
6	ABSOLUTE MAXIMUM RATINGS	16
6.1	Environmental Characteristics.....	16
6.2	Recommended Operating Conditions.....	16
7	DC ELECTRICAL CHARACTERISTICS.....	17
8	DIGITAL I/O SPECIFICATIONS.....	19
9	A/D CONVERTER CHARACTERISTICS.....	20
10	AC ELECTRICAL CHARACTERISTICS.....	20
10.1	TX Power Characteristics.....	22
10.2	Power Settings for Regulatory Compliance	24
11	PHYSICAL DIMENSIONS	25
12	RECOMMENDED REFLOW PROFILE.....	26
13	PRODUCT LABEL DRAWING	27
14	RECOMMENDED FOOTPRINT	28
14.1	Recommended Placement.....	30
14.2	Example carrier board.....	32
15	RELIABILITY TESTS.....	33
16	APPLICATION NOTES	33
16.1	Safety Precautions.....	33
16.2	Design Engineering Notes.....	33
16.3	Storage Conditions	34
17	PACKAGING.....	34
17.1	Embossed Tape	34

17.2	Component Orientation.....	35
17.3	Reel Dimensions.....	35
17.4	Packaging.....	37
18	ORDERING INFORMATION.....	38
19	ROHS DECLARATION.....	39
20	DATA SHEET STATUS.....	39
21	RELATED DOCUMENTS.....	39

Not Recommended for New Designs



Image not shown actual size; enlarged to show detail.

The Telegesis ETRX358x and ETRX358xHR series modules are small outline, low power 2.4GHz ZigBee modules, based on the latest Silicon Labs EM358x family of single chip ZigBee® solutions.

These 4th generation modules have been designed to be integrated into any device without the need for RF experience and expertise. Utilizing the market's premier EmberZNet ZigBee® stack, the ETRX358x series enables you to add powerful wireless networking capability to your products and quickly bring them to market.

For custom application development the ETRX358x series integrates with ease into Ember Desktop development environment.

Module Features

- Small form factor, SMT module 25mm x 19mm
- Same footprint and pin-out as ETRX357
- Side Castellations for easy soldering and optical inspection
- Two antenna options: Integrated chip antenna or U.FL coaxial connector
- Based on 32-bit ARM® Cortex-M3
- Operation at 6, 12 or 24MHz
- Industry standard JTAG Programming and real time packet tracing via the Ember Debug Port
- Up to 512kB of flash and 64kbytes of RAM
- Lowest Deep Sleep Current of 1µA with retained RAM and GPIO and multiple sleep modes
- Wide supply voltage range (2.1 to 3.6V)
- Optional 32.768kHz watch crystal can be added externally
- Can act as an End Device, Router or Coordinator
- 24 general-purpose I/O lines including analogue inputs (all GPIOs of the EM358x SoC are accessible)
- Firmware upgrades via serial port or over the air using the Ember standalone bootloader
- Hardware supported encryption (AES-128)
- CE, FCC and IC compliance, FCC modular approval
- Operating temperature range: -40°C to +85°C
- Long range version with a link budget of up to 124dB available in the same form factor

Radio Features

- Based on the Silicon Labs EM358x family of single chip ZigBee® SoCs
- 2.4GHz ISM Band
- 250kbit/s over the air data rate
- 16 channels (IEEE802.15.4 Channel 11 to 26)
- +3dBm output power (+8dBm in boost mode)
- High sensitivity of -100dBm (-102dBm in boost mode) typically @ 1% packet error rate
- RX Current: 27mA, TX Current: 32mA at 3dBm
- Robust Wi-Fi and Bluetooth coexistence

Suggested Applications

- ZigBee Smart Energy applications
- Wireless Alarms and Security
- Home/Building Automation
- Wireless Sensor Networks
- M2M Industrial Controls
- Lighting and ventilation control
- Remote monitoring
- Environmental monitoring and control

Development Kit

- ETRX3587 Expansion Pack for ETRX357 Development Kit
- ETRX357 Development kit containing everything required to set up a mesh network quickly and evaluate range and performance of the ETRX357 series and its long-range version.
- Custom software development available upon request.

1 Introduction

This document describes the Telegesis ETRX358x and ETRX358xHR family of ZigBee modules which have been designed to be easily integrated into another device and to provide a fast, simple and low cost wireless mesh networking interface.

The Telegesis ETRX3 series modules are based on the Silicon Labs ZigBee compliant platform consisting of the single chip family of EM358x SoCs combined with the ZigBee PRO compliant EmberZNet meshing stack. The ETRX358x and ETRX358xHR modules represent an ideal platform for custom firmware development in conjunction with the Silicon Labs ZigBee development kits.

No RF experience or expertise is required to add this powerful wireless networking capability to your products. The ETRX358x and ETRX358xHR series of modules offer fast integration opportunities and the shortest possible time to market for your product.

1.1 Hardware Description

The main building blocks of the ETRX358x and ETRX358xHR modules are the single chip EM358x SoC from Silicon Labs, a 24MHz reference crystal and RF front-end circuitry optimized for best RF performance. The modules are available with on-board antenna or alternatively a U.FL coaxial connector for attaching external antennae. Modules with the U.FL connector are identified by the "HR" suffix.

The integrated antenna is an Antenova Rufa, and details of the radiation pattern are available from the Antenova website [5].

Module	Chip	Flash	RAM	Antenna	USB
ETRX3581 ¹	EM3581	256kB	32kB	Chip	No
ETRX3581HR ¹	EM3581	256kB	32kB	External	No
ETRX3582 ¹	EM3582	256kB	32kB	Chip	Yes
ETRX3582HR ¹	EM3582	256kB	32kB	External	Yes
ETRX3585 ¹	EM3585	512kB	32kB	Chip	No
ETRX3585HR ¹	EM3585	512kB	32kB	External	No
ETRX3586 ¹	EM3586	512kB	32kB	Chip	Yes
ETRX3586HR ¹	EM3586	512kB	32kB	External	Yes
ETRX3587	EM3587	512kB	64kB	Chip	No
ETRX3587HR	EM3587	512kB	64kB	External	No
ETRX3588 ¹	EM3588	512kB	64kB	Chip	Yes
ETRX3588HR ¹	EM3588	512kB	64kB	External	Yes

Table 1: Module Variants

The ETRX358x and ETRX358xHR are used for ZigBee (www.zigbee.org) applications. In case it is desired to develop custom firmware, the Silicon Labs toolchain, consisting of Ember Desktop together with a comprehensive integrated development environment (IDE), is required.

¹ MOQ and Lead Time applies. Only stocked modules are ETRX3587 and ETRX3587HR

2 Product Approvals

The ETRX358x and ETRX358xHR have been designed to meet all national regulations for world-wide use. In particular the following certifications have been obtained:

2.1 FCC Approvals

The Telegesis ETRX358x family integrated Antenna as well as the ETRX358xHR family including the antennas listed in Table 2 and the power levels listed in section 10.2 have been tested to comply with FCC CFR Part 15 (USA) The devices meet the requirements for modular transmitter approval as detailed in the FCC public notice DA00.1407.transmitter.

FCC statement:

This device complies with Part 15 of the FCC rules. Operation is subject to the following two conditions: (1) this device may not cause harmful interference, and (2) this device must accept any interference received, including interference that may cause undesired operation.



FCC ID: S4GEM358X

This module is approved for use in both portable and mobile applications. The module and associated antenna must be installed to provide a separation distance of at least 0.75cm from all persons and must not transmit simultaneously with any other antenna or transmitter.

Item	Part No.	Manufacturer	Type	Impedance	Gain
1	BT-Stubby (straight)	EAD Ltd. [6]	¼ Wave	50Ω	0dBi
2	BT-Stubby (right-angle)	EAD Ltd. [6]	¼ Wave	50Ω	0dBi
3	CJ-2400-6603	Chang Jia	½ Wave	50 Ω	2.0dBi
4	Rufa (on board)	Antenova	Chip	50Ω	2.1dBi (peak)

Table 2: Approved Antennae

While the applicant for a device into which the ETRX358x or ETRX358xHR with an antenna listed in Table 2 is installed is not required to obtain a new authorization for the module, this does not preclude the possibility that some other form of authorization or testing may be required for the end product depending upon local territorial regulations.

The FCC requires the user to be notified that any changes or modifications made to this device that are not expressly approved by Telegesis (UK) Ltd. may void the user's authority to operate the equipment.

When using the ETRX358xHR family with approved antennae, it is required to prevent end-users from replacing them with non-approved ones.

2.2.1 FCC Labelling Requirements

When integrating the ETRX358x or ETRX358xHR families into a product it must be ensured that the FCC labelling requirements are met. This includes a clearly visible label on the outside of the finished product specifying the Telegesis FCC identifier (**FCC ID: S4GEM358X**) as well as the FCC notice shown on the previous page. This exterior label can use wording such as “**Contains Transmitter Module FCC ID: S4GEM358X**” or “**Contains FCC ID: S4GEM358X**” although any similar wording that expresses the same meaning may be used.

2.2 IC (Industry Canada) Approvals

The Telegesis ETRX358x family with integrated Antenna as well as the ETRX358xHR family have been approved by Industry Canada to operate with the antenna types listed in Table 2 with the maximum permissible gain and required antenna impedance for each antenna type indicated. Antenna types not included in this list, having a gain greater than the maximum gain indicated for that type, are strictly prohibited for use with this device.

IC-ID: 8735A-EM358X

- This device complies with Industry Canada license-exempt RSS standard(s). Operation is subject to the following two conditions: (1) this device may not cause interference, and (2) this device must accept any interference, including interference that may cause undesired operation of the device.
- Under Industry Canada regulations, this radio transmitter may only operate using an antenna of a type and maximum (or lesser) gain approved for the transmitter by Industry Canada. To reduce potential radio interference to other users, the antenna type and its gain should be so chosen that the equivalent isotropically radiated power (e.i.r.p.) is not more than that permitted for successful communication.
- and must not be co-located or operating in conjunction with any other antenna or transmitter. This device has been designed to operate with the power levels shown in section 10.2 with the antennas listed in Table 2, and having a maximum gain of 2.1 dBi. Antennas not included in this list or having a gain greater than 2.1 dBi are strictly prohibited for use with this device. The required antenna impedance is 50 ohms.

French Statements

- Conformément à la réglementation d'Industrie Canada, le présent émetteur radio peut fonctionner avec une antenne d'un type et d'un gain maximal (ou inférieur) approuvé pour l'émetteur par Industrie Canada. Dans le but de réduire les risques de brouillage radioélectrique à l'intention des autres utilisateurs, il faut choisir le type d'antenne et son gain de sorte que la puissance isotrope rayonnée équivalente (p.i.r.e.) ne dépasse pas l'intensité nécessaire à l'établissement d'une communication satisfaisante.
- Le présent appareil est conforme aux CNR d'Industrie Canada applicables aux appareils radio exempts de licence. L'exploitation est autorisée aux deux conditions suivantes : (1) l'appareil ne doit pas produire de brouillage, et (2) l'utilisateur de l'appareil doit accepter tout brouillage radioélectrique subi, même si le brouillage est susceptible d'en compromettre le fonctionnement.

OEM Responsibilities

The ETRX358x and ETRX358x families of module have been certified for integration into products only by OEM integrators under the following condition:

1. The transmitter module must not be co-located or operating in conjunction with any other antenna or transmitter.

As long as the condition above is met, further transmitter testing will not be required. However, the OEM integrator is still responsible for testing their end-product for any additional compliance requirements required with this module installed (for example, digital device emissions, PC peripheral requirements, etc.).

IMPORTANT NOTE: In the event that these conditions can not be met (for certain configurations or co-location with another transmitter), then Industry Canada certification is no longer considered valid and the IC Certification Number can not be used on the final product. In these circumstances, the OEM integrator will be responsible for re-evaluating the end product (including the transmitter) and obtaining a separate Industry Canada authorization.

2.1.1 IC Labelling Requirements

The ETRX358x and ETRX358xHR family modules are labelled with its own IC Certification Number. If the IC Certification Number is not visible when the module is installed inside another device, then the outside of the device into which the module is installed must also display a label referring to the enclosed module. In that case, the final end product must be labelled in a visible area with the following:

“Contains Transmitter Module IC: 8735A-EM358X” or
“Contains IC: 8735A-EM358X”

The OEM of the ETRX358x and ETRX358xHR family modules must only use the approved antenna(s) listed above, which have been certified with this module.

The OEM integrator has to be aware not to provide information to the end user regarding how to install or remove this RF module or change RF related parameters in the user's manual of the end product.

The user's manual for the end product must include the following information in a prominent location:

“To comply with Industry Canada RF radiation exposure limits for general population, the transmitter must not be co-located or operating in conjunction with any other antenna or transmitter.”

2.3 European Certification (ETSI)

The ETRX358x and ETRX358xHR series modules with the power settings defined in section 10.2 are in conformity with the essential requirements and other relevant requirements of the Radio Equipment Directive (RED) (2014/53/EU). These include

- Radio: EN 300 328 v2.1.1
- EMC: EN 301 489-17 v3.1.1
EN 301 489-1 V2.1.1
- Safety: IEC 60950-1:2005, IEC 60950-1:2005/AMD1:2009,
IEC 60950-1:2005/AMD2:2013

Please note that every application using the modules will need to perform the radio EMC tests on the end product, according to EN 301 489-17. It is ultimately the responsibility of the manufacturer to ensure the compliance of the end product. The specific product assembly may have an impact to RF radiated characteristics, and manufacturers should carefully consider RF radiated testing with the end-product assembly. A formal DoC is available via www.silabs.com

The modules are in conformity with the essential requirements and other relevant requirements of the Radio Equipment Directive (RED) with the antennae listed in Table 2.

2.4 Declarations of Conformity

Telegesis (UK) Ltd will issue Declarations of Conformity for all ETRX3 series ZigBee RF Modules, which cover RoHS, Radio Emissions and Safety. These documents will be available from our website or on request.

2.5 IEEE 802.15.4

IEEE 802.15.4 is a standard for low data-rate, wireless networks (raw bit-rate within a radio packet of 250kbps @2.4GHz) which focuses on low cost, low duty cycle, long primary battery life applications as well as mains-powered applications. It is the basis for the open ZigBee Protocol.

2.6 The ZigBee Protocol

The ZigBee Protocol is a set of standards for wireless connectivity for use between any devices over short to medium distances. The specification was originally ratified in December 2004, paving the way for companies to start making low-power networks a reality.

ZigBee uses the IEEE 802.15.4 radio specification running on the 2.4GHz band, plus three additional layers for networking, security and applications. What makes the specification unique is its use of a mesh network architecture which, in bucket chain style, passes data from one node to the next until it lands at its destination. The network is self-healing and adapts its routing as link quality changes or nodes move. Furthermore, nodes can be defined as End Devices which do not act as routers, but can therefore be put into a low-power sleep state.

The enhanced version of the ZigBee standard (or ZigBee 2006) was released in December 2006, adding new features and improvements to the only global wireless communication standard enabling the development of easily deployable low-cost, low-power, monitoring and control products for homes, commercial buildings and industrial plant monitoring. In 2007 the ZigBee Alliance introduced the PRO featureset which offers advantages over earlier versions, including

- Truly self-healing mesh networking
- Messages can now travel up to 30 hops
- Source-Routing for improved point to multipoint message transmission
- Improved security including Trust-Centre link keys
- New message types and options

3 Module Pinout

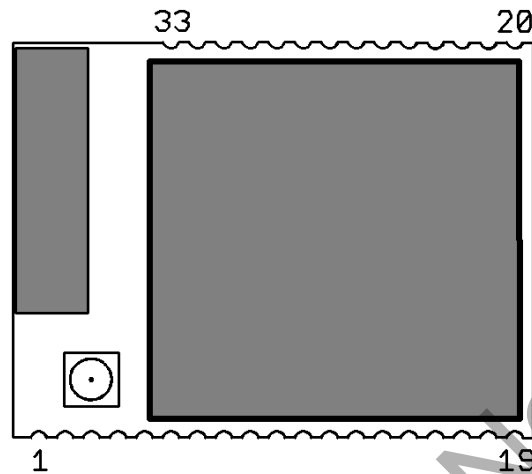

Figure 1: ETRX3 series Module Pinout (top view)

The table below gives details about the pin assignment for direct SMD soldering of the ETRX3 series modules to the application board. For more information on the alternate functions please refer to [2].

All GND pads are connected within the module, but for best RF performance all of them should be grounded externally ideally to a ground plane.

“Important Note: If designers would like to keep open the option of using either standard or long range modules in the same product please note the following. The ETRX358x series and the ETRX358x-LRS series of modules are footprint compatible, but on the ETRX358x-LRS series pins PB0 and PC5 of the EM358x are used internally to control the front-end module and are not available to the user.”

ETRX358x Pad	Name	EM358x Pin	Default use	Alternate Functions
1	GND	GND	GND	
2	PC5 {1}	11		TX_ACTIVE
3	PC6	13	I/O	OSC32B, nTX_ACTIVE
4	PC7	14	I/O	OSC32A, OSC32_EXT
5	PA7 {4}	18	I/O	TIM1C4
6	PB3 {2}	19	I/O, CTS	SC1nCTS, SC1SCLK, TIM2C3
7	nReset {5}	12	nReset	
8	PB4 {2}	20	I/O, RTS	TIM2C4, SC1nRTS, SC1nSSEL
9	PA0	21	I/O	TIM2C1, SC2MOSI, USBDM{6}
10	PA1	22	I/O	TIM2C3, SC2SDA, SC2MISO, USBDP{6}
11	PA2	24	I/O	TIM2C4, SC2SCL, SC2SCLK
12	PA3	25	I/O	SC2nSSEL, TIM2C2
13	GND	GND	GND	
14	PA4	26	I/O	ADC4, PTI_EN, TRACEDATA2
15	PA5 {3}	27	I/O	ADC5, PTI_DATA, nBOOTMODE, TRACEDATA3
16	PA6 {4}	29	I/O	TIM1C3
17	PB1	30	TXD	SC1MISO, SC1MOSI, SC1SDA, SC1TXD, TIM2C1
18	PB2	31	RXD	SC1MISO, SC1MOSI, SC1SCL, SC1RXD, TIM2C2
19	GND	GND	GND	
20	GND	GND	GND	
21	JTCK	32		SWCLK
22	PC2	33	I/O	JTDO, SWO, TRACEDATA0
23	PC3	34	I/O	JTDI, TRACECLK
24	PC4	35	I/O	JTMS, SWDIO
25	PB0	36	I/O, IRQ	VREF, IRQA, TRACEDATA2, TIM1CLK, TIM2MSK
26	PC1	38	I/O	ADC3, TRACEDATA3
27	PC0 {4}	40	I/O	JRST, IRQD, TRACEDATA1
28	PB7 {4}	41	I/O	ADC2, IRQC, TIM1C2
29	PB6 {4}	42	I/O	ADC1, IRQB, TIM1C1
30	PB5	43	I/O	ADC0, TIM2CLK, TIM1MSK
31	GND	GND	GND	
32	Vcc	Vcc	Vcc	

Table 3: Pin Information
Notes:

- {1} When the alternate function is selected, TX_ACTIVE becomes an output that indicates that the EM358x radio circuit is in transmit mode. PC5 is not usable on the long range version of the ETRX358x as this GPIO is used internally as TX_ACTIVE to control the external RF frontend.
- {2} The serial UART connections TXD, RXD, CTS and RTS are PB1, PB2, PB3 and PB4 respectively
- {3} If PA5 is driven low at power-up or reset the module will boot up in the bootloader
- {4} PA6, PA7, PB6, PB7 and PC0 can drive high current (see section 8)
- {5} nRESET is level-sensitive, not edge-sensitive. The module is held in the reset state while nRESET is low.
- {6} ETRX3588, ETRX3586, ETRX3582 and ETRX3588HR, ETRX3586HR, ETRX3582HR variants only

See also the table “Module pads and functions” in the ETRX357 Development Kit Product Manual. Refer to the Silicon Labs EM358x manual for details of the alternate functions and pin names.

4 Hardware Description

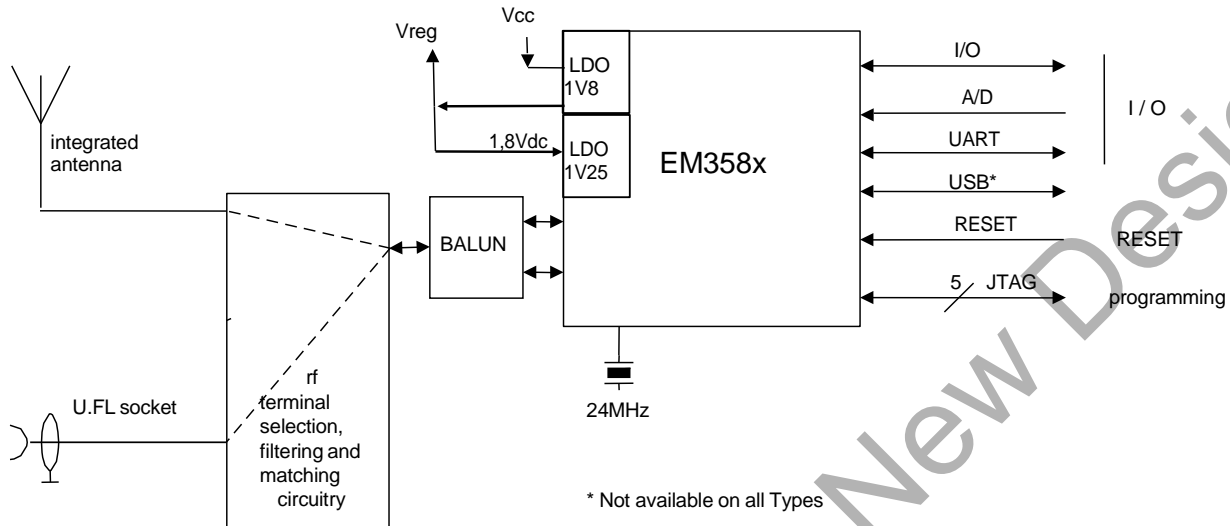

Figure 2: Hardware Diagram

The ETRX358x and ETRX358xHR families are based on the Silicon Labs EM358x family of ZigBee SoCs. The EM358x and EM358xHR are fully integrated 2.4GHz ZigBee transceivers with a 32-bit ARM® Cortex M3™ microprocessor, flash and RAM memory, and peripherals.

The industry standard serial wire and JTAG programming and debugging interfaces together with the standard ARM system debug components help to streamline any custom software development.

In addition to this a number of MAC functions are also implemented in hardware to help maintaining the strict timing requirements imposed by the ZigBee and IEEE802.15.4 standards.

The new advanced power management features allow faster wakeup from sleep and new power down modes allowing this 4th generation module to offer a longer battery life than any 1st and 2nd generation modules on the market.

The EM358x modules have fully integrated voltage regulators for both required 1.8V and 1.25V supply voltages. The voltages are monitored (brown-out detection) and the built in power-on-reset circuit eliminates the need for any external monitoring circuitry. An optional 32.768 kHz watch crystal can be connected externally to pads 3 and 4 in case more accurate timing is required. To utilize the external watch crystal custom firmware is required.

4.1 Hardware Interface

All GPIO pins of the EM358x chips are accessible on the module's pads. Whether signals are used as general purpose I/Os, or assigned to a peripheral function like ADC is set by the firmware. When developing custom firmware please refer to the EM358x datasheet [2].

5 Firmware Description

By default, the modules will be pre-loaded with a standalone bootloader which supports over-the-air bootloading as well as serial bootloading of new firmware.

In order to enter the standalone bootloader using a hardware trigger pull PA5 to ground and power-cycle or reset the module. To avoid entering the standalone bootloader unintentionally make sure not to pull this pin down during boot-up unless the resistance to ground is $>10k\Omega$. (A pull-up is not required).

Each module comes with a unique 64-bit 802.15.4 identifier which is stored in non-volatile memory. A router is typically a mains powered device whilst a sleepy end device (SED) can be battery powered.

The module is also able to act as a coordinator and Trust Centre through external host control.

Not Recommended for New Designs

5.1 Token Settings

The ETRX358x Series Modules' manufacturing tokens will be pre-programmed with the settings shown in the table below.

Token	Description	TG Default
MFG_CIB_OBS	Option Bytes	<not written>
MFG_CUSTOM_VERSION	Optional Version Number	<not written>
MFG_CUSTOM_EUI_64	Custom EUI	<not written>
MFG_STRING	Device Specific String	TELEGESIS
MFG_BOARD_NAME	Hardware Identifier	<Order Code>
MFG_MANUF_ID	Manufacturer ID	0x1010
MFG_PHY_CONFIG	Default Power Settings	0xFF26
MFG_BOOTLOAD_AES_KEY	Bootloader Key	<not written>
MFG_EZSP_STORAGE	EZSP related	<not written>
MFG_CBKE_DATA	SE Security	<not written>
MFG_INSTALLATION_CODE	SE Installation	<not written>
MFG_OSC24M_BIAS_TRIM	Crystal Bias	<not written>
MFG_SYNTH_FREQ_OFFSET	Frequency offset	<not written>
MFG_OSC24M_SETTLE_DELAY	Crystal Stabilizing Time	<not written>
MFG_SECURITY_CONFIG	Security Settings	<not written>
MFG_CCA_THRESHOLD	CCA Threshold	<not written>
MFG_SECURE_BOOTLOADER_KEY	Secure Bootloader Key	<not written>

Table 4. Manufacturing tokens

5.2 Custom Firmware

The ETRX358x series of modules is an ideal platform for developing custom firmware. In order to develop custom firmware the Silicon Labs Ember toolchain is required.

6 Absolute Maximum Ratings

No.	Item	Symbol	Absolute Maximum Ratings	Unit
1	Supply voltage	V _{CC}	-0.3 to +3.6	Vdc
2	Voltage on any Pad	V _{in}	-0.3 to V _{CC} +0.3	Vdc
3	Voltage on any Pad pin (PA4, PA5, PB5, PB6, PB7, PC1), when used as an input to the general purpose ADC with the low voltage range selected	V _{in}	-0.3 to +2.0	Vdc
4	Module storage temperature range	T _{stg}	-40 to +105	°C
5	Reel storage temperature range	T _{stgreel}	0 to 75	°C
6	Operating temperature range	T _{op}	-40 to +85	°C
7	Input RF level	P _{max}	15	dBm
8	Reflow temperature	T _{Death}	Please refer to chapter 12	°C

Table 5: Absolute Maximum Ratings

The absolute maximum ratings given above should under no circumstances be violated. Exceeding one or more of the limiting values may cause permanent damage to the device.



Caution! ESD sensitive device. Precautions should be used when handling the device in order to prevent permanent damage.

6.1 Environmental Characteristics

No.	Item	Symbol	Absolute Maximum Ratings	Unit
1	ESD on any pad according to Human Body Model (HBM) circuit description	V _{THBM}	±2	kV
2	ESD on non-RF pads according to Charged Device Model (CDM) circuit description	V _{THCDM}	±400	V
3	ESD on RF terminal according to Charged Device Model (CDM) circuit description	V _{THCDM}	±225	V
4	Moisture Sensitivity Level	MSL	MSL3, per J-STD-033	

Table 6: Absolute Maximum Ratings

6.2 Recommended Operating Conditions

No.	Item	Conditon/ Remark	Symbol	Value			Unit
				Min	Typ	Max	
1	Supply voltage		V _{CC}	2.1		3.6	Vdc
2	RF Input Frequency		f _c	2405		2480	MHz
3	RF Input Power		P _{IN}			0	dBm
4	Operating temperature range		T _{op}	-40		+85	°C

Table 7: Recommended Operating Conditions

7 DC Electrical Characteristics

$V_{CC} = 3.0V$, $T_{AMB} = 25^{\circ}C$, NORMAL MODE (non-Boost) unless otherwise stated.

No.	Item	Condition / Remark	Symbol	Value			Unit
				Min	Typ	Max	
1	Module supply voltage		V_{CC}	2.1		3.6	Vdc
Deep Sleep Current							
2	Quiescent current, internal RC oscillator disabled,	4kB RAM retained	I_{SLEEP}		1.0		μA
3	Quiescent current, internal RC oscillator enabled	4kB RAM retained	I_{SLEEP}		1.25		μA
4	Quiescent current, including 32.768kHz oscillator	4kB RAM retained	I_{SLEEP}		1.6		μA
5	Quiescent current including internal RC oscillator and 32.768kHz oscillator	4kB RAM retained	I_{SLEEP}		1.9		μA
6	Additional current per 4kB block of RAM retained		$I_{RAMSLEEP}$		0,067		μA
Reset Current							
7	Quiescent current nReset asserted		I_{RESET}		2	3	mA
Processor and Peripheral Currents							
8	ARM® Cortex™ M3, RAM and flash memory	25°C, 12MHz Core clock	I_{MCU}		7.5		mA
9	ARM® Cortex™ M3, RAM and flash memory	25°C, 24MHz Core clock	I_{MCU}		8.5		mA
10	ARM® Cortex™ M3, RAM and flash memory sleep current	25°C, 12MHz Core clock	I_{MCU}		4.0		mA
11	ARM® Cortex™ M3, RAM and flash memory sleep current	25°C, 6MHz Core clock	I_{MCU}		2.5		mA
12	Serial controller current	Per serial controller at max. clock rate	I_{SC}		0.2		mA
13	General purpose timer current	Per timer at max. clock rate	I_{TIM}		0.25		mA
14	General purpose ADC current	Max. Sample rate, DMA	I_{ADC}		1.1		mA
15	USB Active Current		I_{USB}		1		mA
16	USB Suspend Mode Current		$I_{USBSUSP}$			2.5	mA
RX Current							
17	Radio receiver MAC and Baseband	ARM® Cortex™ M3 sleeping.	I_{RX}		23.5		mA
18	Receive current consumption	Total, 12MHz clock speed	I_{RX}		27		mA
19	Receive current consumption	Total, 24MHz clock speed	I_{RX}		28		mA
20	Receive current consumption BOOST MODE	Total, 12MHz clock speed	I_{RX}		29		mA
21	Receive current consumption BOOST MODE	Total, 24MHz clock speed	I_{RX}		30		mA

TX Current							
22	Transmit current consumption	at +3dBm module output power, CPU at 12MHz	I_{TXVCC}		31.5		mA
23	Transmit Current consumption BOOST MODE	at +8dBm module output power, CPU at 12MHz	I_{TXVCC}		44		mA
24	Transmit current consumption	at +0dBm module output power, CPU at 12MHz	I_{TXVCC}		29		mA
25	Transmit current consumption	at min. module output power, CPU at 12MHz	I_{TXVCC}		24		mA
26	Transmit current consumption	at +8dBm module output power, CPU at 24MHz	I_{TXVCC}		45		mA
26	Wake time from deep sleep	From wakeup event to 1 st instruction			110		μ s
27	Shutdown time	From last instruction into deep sleep			5		μ s

Table 1: DC Electrical Characteristics

Please Note: The average current consumption during operation is dependent on the firmware and the network load.

8 Digital I/O Specifications

The digital I/Os of the ETRX35x module

$V_{CC} = 3.0V$, $T_{AMB} = 25^{\circ}C$, NORMAL MODE unless otherwise stated

No.	Item	Condition / Remark	Symbol	Value			Unit
				Min	Typ	Max	
1	Low Schmitt switching threshold	Schmitt input threshold going from high to low	V_{SWIL}	$0.42 \times V_{CC}$		$0.5 \times V_{CC}$	Vdc
2	High Schmitt switching threshold	Schmitt input threshold going from low to high	V_{SWIH}	$0.62 \times V_{CC}$		$0.8 \times V_{CC}$	Vdc
3	Input current for logic 0		I_{IL}			-0.5	μA
4	Input current for logic 1		I_{IH}			0.5	μA
5	Input Pull-up resistor value		R_{IPU}	24	29	34	k Ω
6	Input Pull-down resistor value		R_{IPD}	24	29	34	k Ω
7	Output voltage for logic 0	$I_{OL} = 4mA$ (8mA) for standard (high current) pads	V_{OL}	0		$0.18 \times V_{CC}$	V
8	Output voltage for logic 1	$I_{OH} = 4mA$ (8mA) for standard (high current) pads	V_{OH}	$0.82 \times V_{CC}$		V_{CC}	V
9	Output Source Current	Standard current pad	I_{OHS}			4	mA
10	Output Sink current	Standard current pad	I_{OLS}			4	mA
11	Output Source Current	High current pad (1)	I_{OHH}			8	mA
12	Output Sink current	High current pad (1)	I_{OLH}			8	mA
13	Total output current		$I_{OH} + I_{OL}$			40	mA

Table 9. Digital I/O Specifications

No.	Item	Condition / Remark	Symbol	Value			Unit
				Min	Typ	Max	
1	Low Schmitt switching threshold	Schmitt input threshold going from high to low	V_{SWIL}	$0.42 \times V_{CC}$		$0.5 \times V_{CC}$	Vdc
2	High Schmitt switching threshold	Schmitt input threshold going from low to high	V_{SWIH}	$0.62 \times V_{CC}$		$0.68 \times V_{CC}$	Vdc
3	Input current for logic 0		I_{IL}			-0.5	μA
4	Input current for logic 1		I_{IH}			0.5	μA
5	Input Pull-up resistor value	Chip not reset	R_{IPU}	24	29	34	k Ω
6	Input Pull-up resistor value	Chip reset	$R_{IPURESET}$	12	14.5	17	k Ω

Table 10. nReset Pin Specifications

Notes

- 1) High current pads are PA6, PA7, PB6, PB7, PC0

9 A/D Converter Characteristics

The ADC is a first-order sigma-delta converter. For additional information on the ADC please refer to the EM358x datasheet.

No.	Item	
1	A/D resolution	Up to 14 bits
2	A/D sample time for 7-bit conversion	5.33 μ s (188kHz)
3	A/D sample time for 14-bit conversion	682 μ s
4	Reference Voltage	1.2V

Table 11. A/D Converter Characteristics

10 AC Electrical Characteristics

V_{CC} = 3.0V, T_{AMB} = 25°C, NORMAL MODE measured at 50 Ω terminal load connected to the U.FL socket

No.	Receiver	Value			Unit
		Min	Typ	Max	
1	Frequency range	2400		2500	MHz
2	Sensitivity for 1% Packet Error Rate (PER)		-100	-94	dBm
3	Sensitivity for 1% Packet Error Rate (PER) BOOST MODE		-102	-96	dBm
4	Saturation (maximum input level for correct operation)	0			dBm
5	High-Side Adjacent Channel Rejection (1% PER and desired signal -82dBm acc. to [1])		35		dB
6	Low-Side Adjacent Channel Rejection (1% PER and desired signal -82dBm acc. to [1])		35		dB
7	2 nd High-Side Adjacent Channel Rejection (1% PER and desired signal -82dBm acc. to [1])		46		dB
8	2 nd Low-Side Adjacent Channel Rejection (1% PER and desired signal -82dBm acc. to [1])		46		dB
9	Channel Rejection for all other channels (1% PER and desired signal -82dBm acc. to [1])		40		dB
10	802.11g rejection centred at +12MHz or -13MHz (1% PER and desired signal -82dBm acc. to [1])		36		dB
11	Co-channel rejection (1% PER and desired signal -82dBm acc. to [1])		-6		dBc
12	Relative frequency error (2x40ppm required by [1])	-120		120	ppm
13	Relative timing error (2x40ppm required by [1])	-120		120	ppm
14	Linear RSSI range	40			dB
15	Output power at highest power setting NORMAL MODE BOOST MODE	0	3 8		dBm
16	Output power at lowest power setting		-55		dBm
17	Error vector magnitude as per IEEE802.15.4		5	15	%
18	Carrier frequency error	-40		40	ppm
19	PSD mask relative 3.5MHz distance from carrier	-20			dB
20	PSD mask absolute 3.5MHz distance from carrier	-30			dBm

Table 12. RF Electrical Characteristics

Please Note: For the relationship between EM358x power settings and module output power please relate to chapter 10.1 of this document. When developing custom firmware the output power settings described in this document relate directly to the EM358x power settings accessible via the Ember stack API.

No.	Synthesiser Characteristics	Limit			Unit
		Min	Typ	Max	
22	Frequency range	2400		2500	MHz
23	Frequency resolution		11.7		kHz
24	Lock time from off state, with correct VCO DAC settings			100	µs
25	Relock time, channel change or Rx/Tx turnaround			100	µs
26	Phase noise at 100kHz offset		-75dBc/Hz		
27	Phase noise at 1MHz offset		-100dBc/Hz		
28	Phase noise at 4MHz offset		-108dBc/Hz		
29	Phase noise at 10MHz offset		-114dBc/Hz		

Table 13: Synthesizer Characteristics

No.	Power On Reset (POR) Specifications	Limit			Unit
		Min	Typ	Max	
30	V _{CC} POR release	0.62	0.95	1.2	Vdc
31	V _{CC} POR assert	0.45	0.65	0.85	Vdc

Table 14: Power On Reset Specifications

No.	nRESET Specifications	Limit			Unit
		Min	Typ	Max	
32	Reset Filter Time constant	2.1	12	16	µs
33	Reset Pulse width to guarantee a reset	26			µs
34	Reset Pulse width guaranteed not to cause reset	0		1	µs

Table 15: nReset Specifications

10.1 TX Power Characteristics

The diagrams below show the typical output power and module current in dependency on module EM3588 power setting. Power settings above 3dBm have Boost Mode enabled. Please note that the output power is independent of the supply voltage as the radio is supplied by an internally regulated voltage.

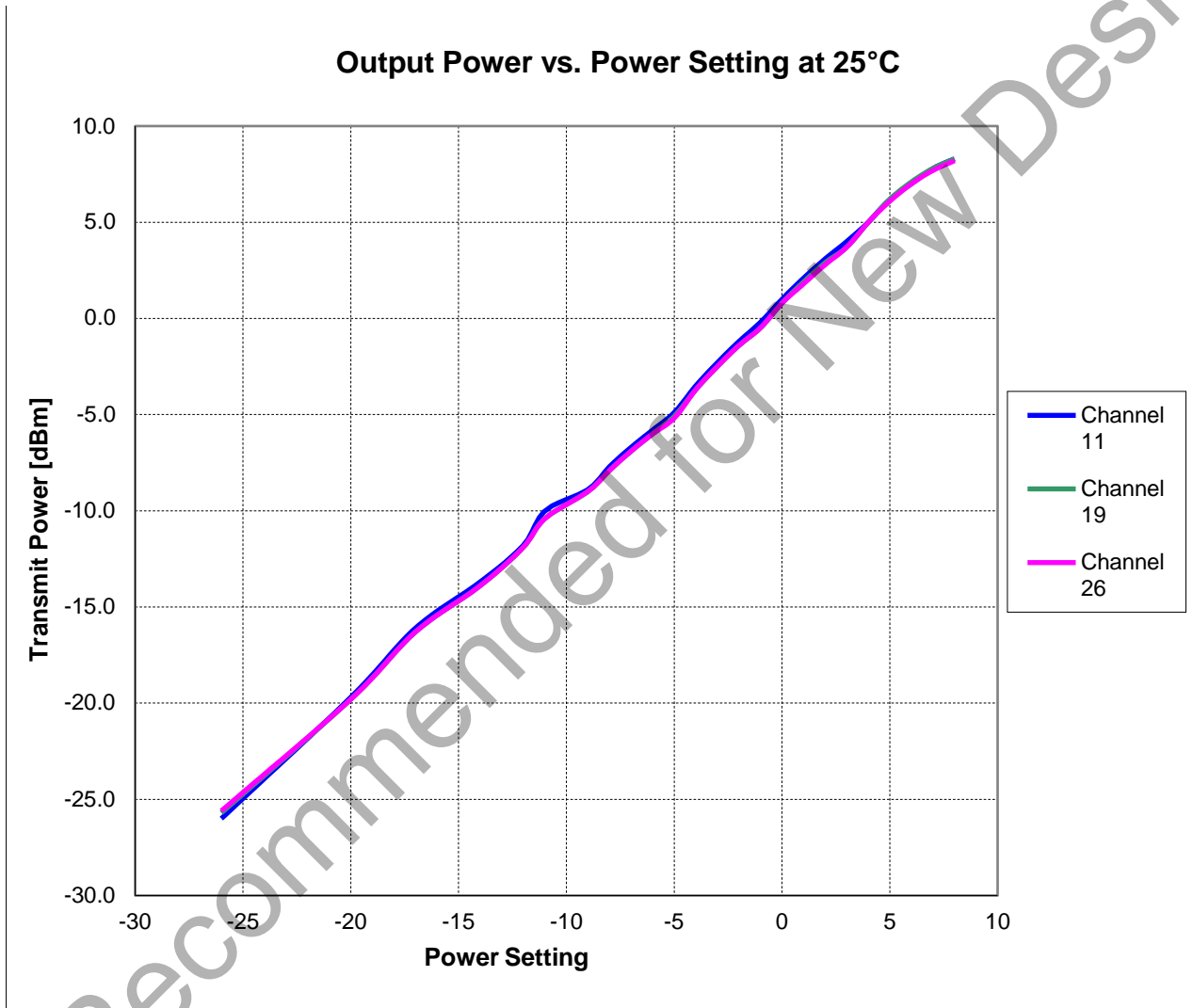

Figure 3: Output Power vs. Power Setting (BOOST mode activated from Power setting of 4 upwards)

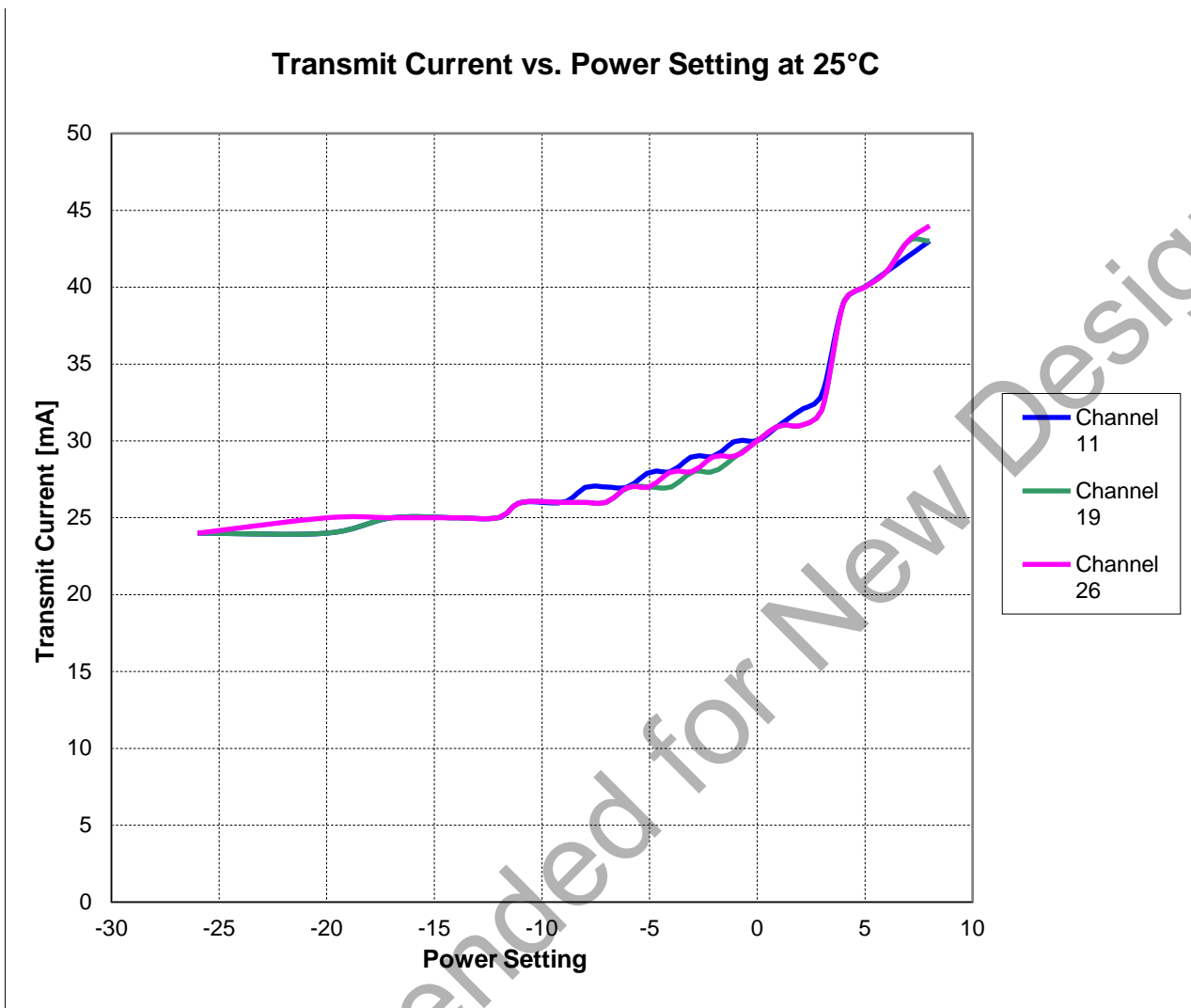

Figure 4: Module Current vs. Power Setting (BOOST mode activated from Power setting of 4 upwards)

Not Recommended for New Designs

10.2 Power Settings for Regulatory Compliance

Due to national restrictions the maximum power levels of the ETRX358x and ETRX358xHR family of modules need to be adjusted as shown in the tables below. The default power setting of the EmberZNet stack is +3dBm.

Antenna	Channels 11-18	Channels 19-24	Channel 25	Channel 26
1/2 Wave	8dBm boost	8dBm boost	8dBm boost	8dBm boost
1/4 Wave	8dBm boost	8dBm boost	8dBm boost	8dBm boost
On Board	8dBm boost	8dBm boost	8dBm boost	8dBm boost

Table 10: Maximum Power Settings for European Compliance

Finally Table 11 lists the maximum Power settings for FCC, IC and C-Tick compliance.

Antenna	Channels 11-18	Channels 19-24	Channel 25	Channel 26
1/2 Wave	8dBm boost	8dBm boost	7dBm boost	-8dBm normal
1/4 Wave	8dBm boost	8dBm boost	7dBm boost	-8dB normal
On Board	8dBm boost	8dBm boost	7dBm boost	-8dB normal

Table 11: Maximum Power Settings for FCC, IC Compliance

11 Physical Dimensions

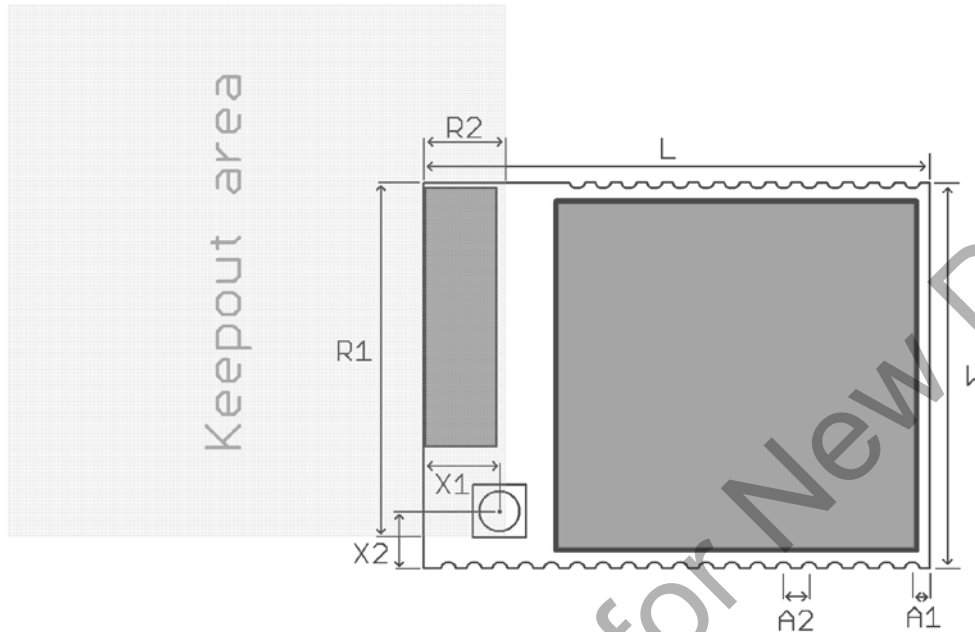

Figure 5: ETRX3 Physical Dimensions

Symbol	Explanation	Typical Distance
L	Length of the module	25.0mm
W	Width of the module	19.0mm
H	Height of the module	3.8mm
A1	Distance centre of pad PCB edge	0.9mm
A2	Pitch	1.27mm
R1	Keep-out Zone from corner of PCB	17.5mm
R2	Keep-out Zone from corner of PCB	4.1mm
X1	Distance centre of Antenna connector PCB edge	3.8mm
X2	Distance centre of Antenna connector PCB edge	2.8mm

Table 12: ETRX3 Physical Dimensions

For ideal RF performance when using the on-board antenna, the antenna should be located at the corner of the carrier PCB. There should be no components, tracks or copper planes in the keep-out area which should be as large as possible. When using the U.FL RF connector the keep-out area does not have to be obeyed. **Note:** The modules' transmit/receive range will depend on the antenna used and also the housing of the finished product.

12 Recommended Reflow Profile

Recommended temperature profile for reflow soldering

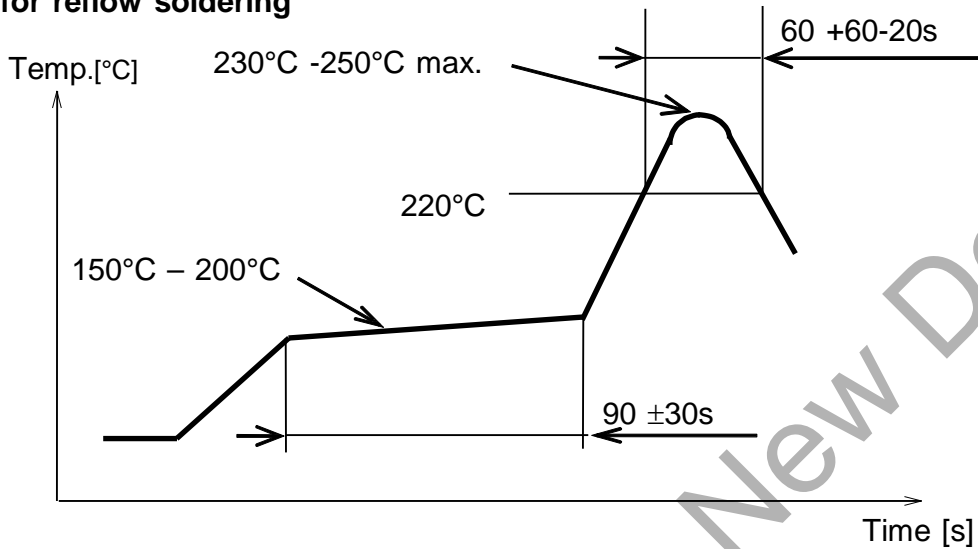

Figure 6. Recommended Reflow Profile

Use of “No-Clean” solder paste is recommended to avoid the requirement for a cleaning process. Cleaning the module is strongly discouraged because it will be difficult to ensure no cleaning agent and other residuals are remaining underneath the shielding can as well as in the gap between the module and the host board.

Please Note:

Maximum number of reflow cycles: 2

Opposite-side reflow is prohibited due to the module’s weight. (i.e. you must not place the module on the bottom / underside of your PCB and re-flow).

13 Product Label Drawing

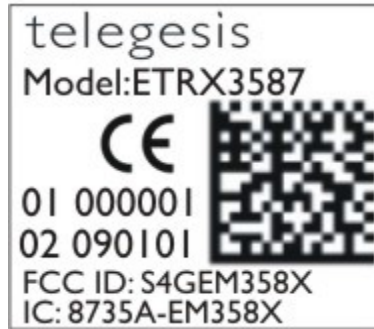

Figure 7: Product Label

The label dimensions are 16.0mm x 14.0 mm. The label will withstand temperatures and chemicals used during a typical manufacturing process.

Example imprint	Description
ETRX358xHR	Module Order code Possible codes are: - ETRX3581 - ETRX3581HR - ETRX3582 - ETRX3582HR - ETRX3585 - ETRX3585HR - ETRX3586 - ETRX3586HR - ETRX3587 - ETRX3587HR - ETRX3588 - ETRX3588HR
000001	Indication for the serial number.
090101	Production Date Code in the format YYMMDD, e.g. 090602
01	Indication for batch number
02	Indication for the production location (first character) and the hardware revision (second character)
FCC ID: S4GEM358X	FCC ID code for this product
IC: 8735A-EM358X	The IC ID
CE	The CE Mark
2D-Barcode	Information in the Datamatrix 2D-Barcode are the serial number [6 characters], the Part-Order code [12 characters], identifier for the batch number [2 characters], the identifier for the hardware release [2 characters] and the production date code in the format Year-Month-Day [6 characters], all separated by a semicolon.

Table 13: ETRX358x Label Details

14 Recommended Footprint

In order to surface mount an ETRX3 series module, we recommend that you use pads which are 1mm wide and 1.2mm high. You must retain the keep-out zone shown in section 11, and ensure that this keep-out area is free of components, copper tracks and/or copper planes/layers.

You must also ensure that there is no exposed copper on your layout which may contact with the underside of the ETRX3 series module.

For best RF performance it is required to provide good ground connections to the ground pads of the module. It is recommended to use multiple vias between each ground pad and a solid ground plane to minimize inductance in the ground path.

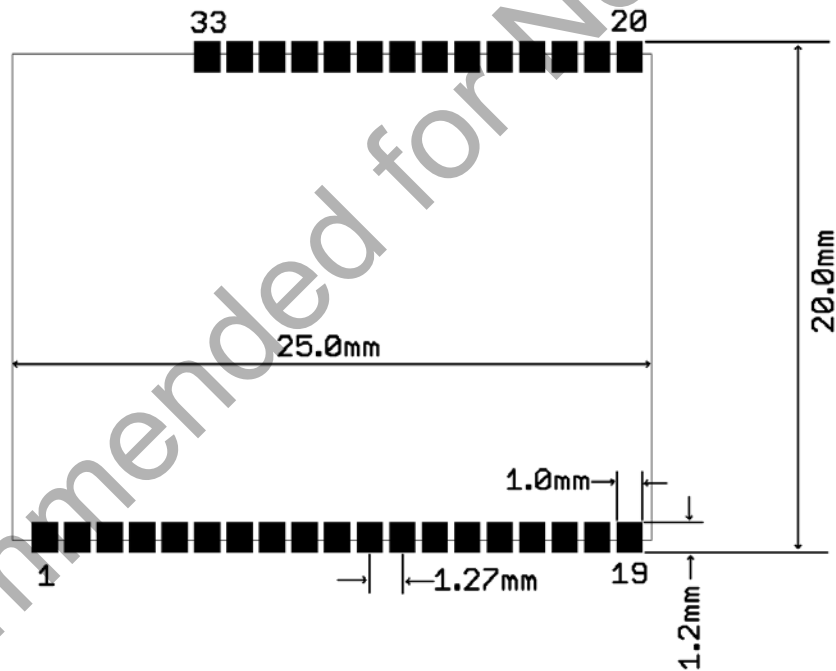

Figure 8: Recommended Footprint

The land pattern dimensions above serve as a guideline.

We recommend that you use the same pad dimensions for the solder paste screen as you have for the copper pads. However these sizes and shapes may need to be varied depending on your soldering processes and your individual production standards. We recommend a paste screen thickness of 120µm to 150µm.

Figure 9 shows the typical pad dimensions of the module and Figure 10-Figure 12 in section 14.1 show examples of how to align the module on its host PCB.

Although the undersides of the ETRX3 series modules are fully coated, no exposed copper, such as uncovered through-hole vias, planes or tracks on your board component layer, should be located below the ETRX3 series module in order to avoid 'shorts'. All ETRX3 series modules use a multilayer PCB containing an inner RF shielding ground plane, therefore there is no need to have an additional copper plane directly under the ETRX3 series module.

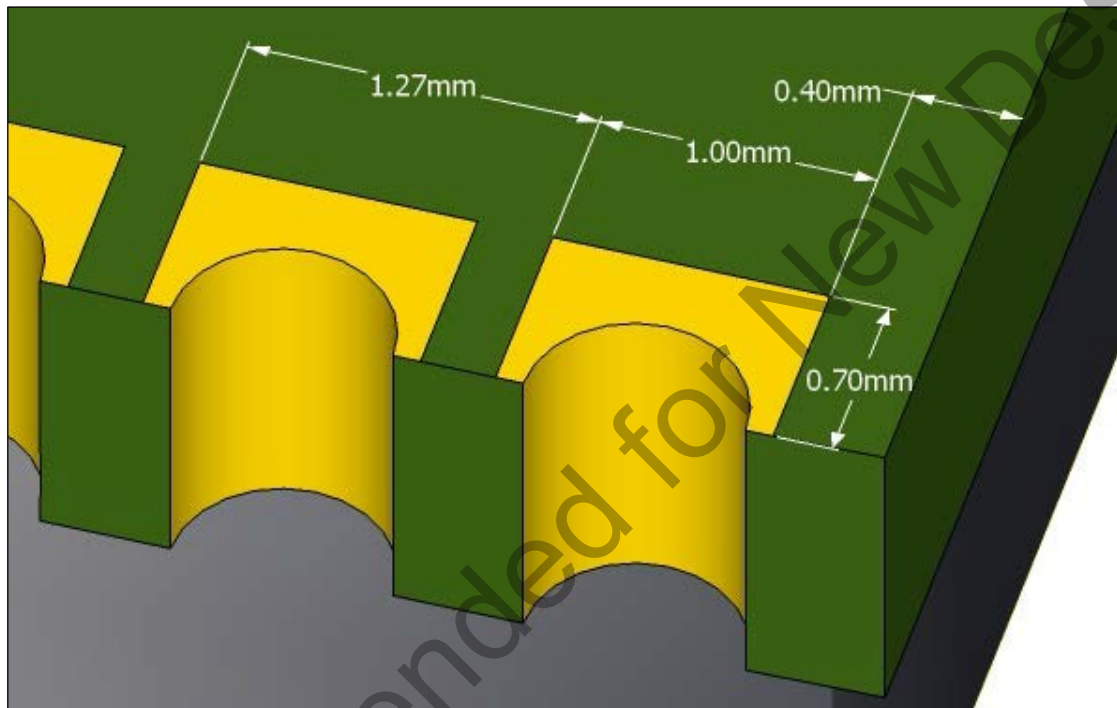

Figure 9. Typical pad dimensions

Finally it is recommended to use no clean flux when soldering the ETRX358x family of modules and to not use a washing process after reflow. If the process does require washing then care must be taken that no washing agent is trapped underneath the shielding can after the drying process has completed.

14.1 Recommended Placement

When placing the module please either locate the antenna in the corner as shown in Figure 10 so that the recommended antenna keepout zone is being followed, or add a no copper zone as indicated in Figure 12.

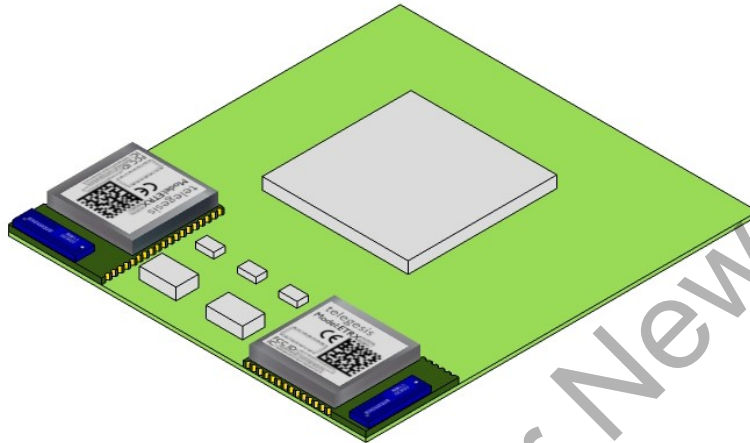

Figure 10. Typical placement

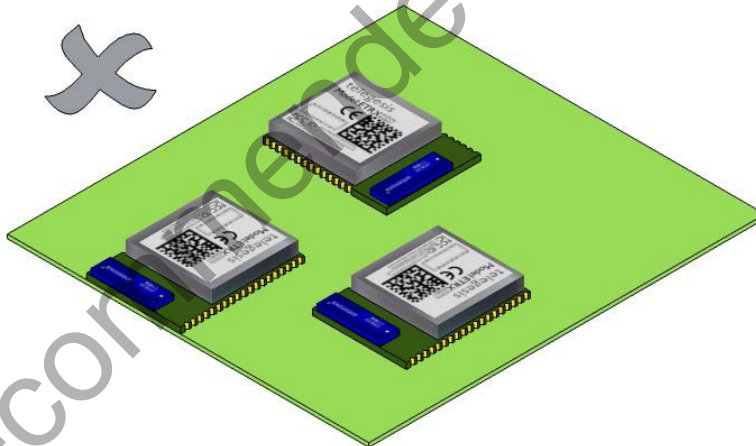

Figure 11. How to not place the Module

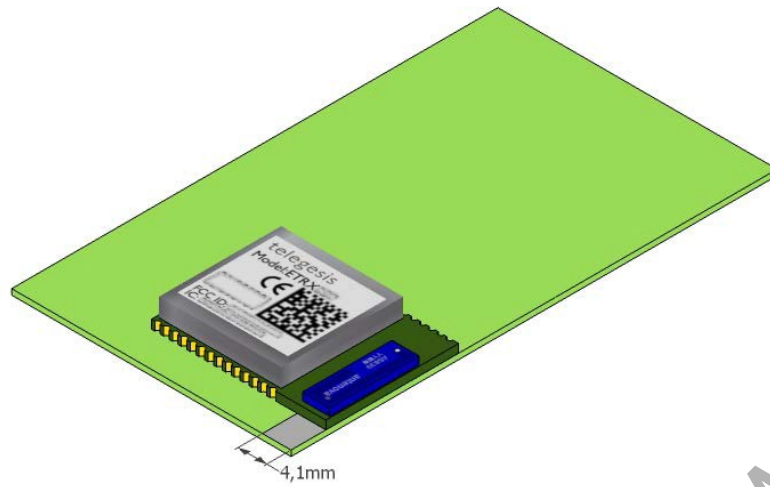

Figure 12. Adding a no copper / no component area

Not Recommended for New Designs

14.2 Example carrier board

Since the RF performance of the module with the on board antenna is strongly dependent on the proper location of the module on its carrier board, Figure 13 shows the reference carrier board which was used during testing by Telegesis.

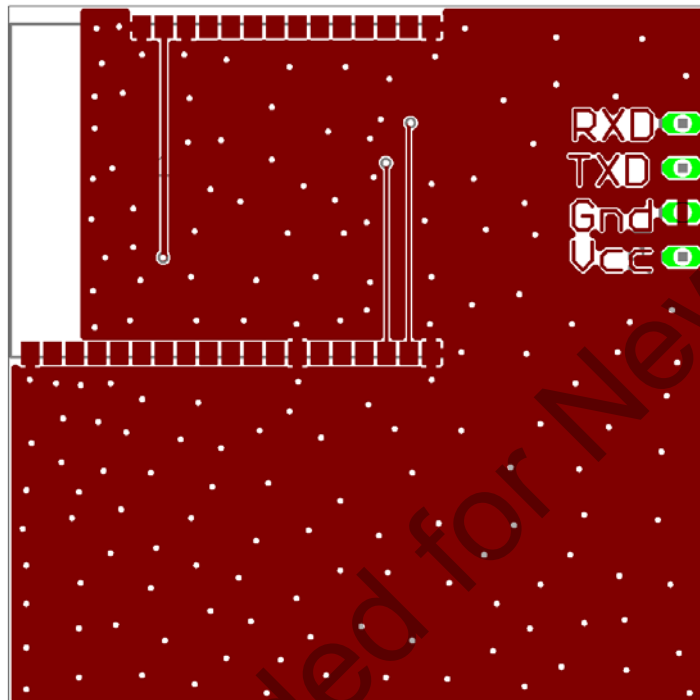

Figure 13. Reference Board

For best performance it is recommended to locate the antenna towards the corner of the carrier board and to respect the recommended keep-out areas as described in section 11.

Finally to provide a good reference ground to the on board antenna, the carrier board should have a ground plane spanning no less than 40 x 40mm. In many cases a smaller ground plane will suffice, but degradation in radio performance could be the result.

15 Reliability Tests

The measurements below have been conducted on random samples out of mass production and passed after the module has been exposed to standard room temperature and humidity for 1 hour.

No	Item	Limit	Condition
1	Vibration test	Electrical parameter should be in specification	Freq.:40Hz,Amplitude:1.5mm 20min. / cycle,1hrs. each of X and Y axis
2	Shock test	the same as the above	Dropped onto hard wood from height of 50cm for 10 times
3	Heat cycle test	the same as the above	-40°C for 30min. and +85°C for 30min.; each temperature 300 cycles
5	Low temp. test	the same as the above	-40°C, 300h
6	High temp. test	the same as the above	+85°C, 300h

Table 14: Reliability Tests

16 Application Notes

16.1 Safety Precautions

These specifications are intended to preserve the quality assurance of products as individual components.

Before use, check and evaluate the module's operation when mounted on your products. Abide by these specifications when using the products. These products may short-circuit. If electrical shocks, smoke, fire, and/or accidents involving human life are anticipated when a short circuit occurs, then provide the following failsafe functions as a minimum:

- (1) Ensure the safety of the whole system by installing a protection circuit and a protection device.
- (2) Ensure the safety of the whole system by installing a redundant circuit or another system to prevent a single fault causing an unsafe status.

16.2 Design Engineering Notes

- (1) Heat is the major cause of shortening the life of the modules. Avoid assembly and use of the target equipment in conditions where the product's temperature may exceed the maximum allowable.
- (2) Failure to do so may result in degrading of the product's functions and damage to the product.
- (3) If pulses or other transient loads (a large load applied in a short time) are applied to the products, before use, check and evaluate their operation when assembled onto your products.
- (4) These products are not intended for other uses, other than under the special conditions shown below. Before using these products under such special conditions, check their performance and reliability under the said special conditions carefully, to determine whether or not they can be used in such a manner.
- (5) In liquid, such as water, salt water, oil, alkali, or organic solvent, or in places where liquid may splash.
- (6) In direct sunlight, outdoors, or in a dusty environment

- (7) In an environment where condensation occurs.
- (8) In an environment with a high concentration of harmful gas (e.g. salty air, HCl, Cl₂, SO₂, H₂S, NH₃, and NO_x)
- (9) If an abnormal voltage is applied due to a problem occurring in other components or circuits, replace these products with new products because they may not be able to provide normal performance even if their electronic characteristics and appearances appear satisfactory.
- (10) Mechanical stress during assembly of the board and operation has to be avoided.
- (11) Pressing on parts of the metal cover or fastening objects to the metal cover is not permitted.

16.3 Storage Conditions

- (1) The module must not be stressed mechanically during storage.
- (2) Do not store these products in the following conditions or the performance characteristics of the product, such as RF performance, may well be adversely affected:
- (3) Storage in salty air or in an environment with a high concentration of corrosive gas, such as Cl₂, H₂S, NH₃, SO₂, or NO_x
- (4) Storage (before assembly of the end product) of the modules for more than one year after the date of delivery at your company even if all the above conditions (1) to (3) have been met, should be avoided.

17 Packaging

17.1 Embossed Tape

- (1) Dimensions of the tape

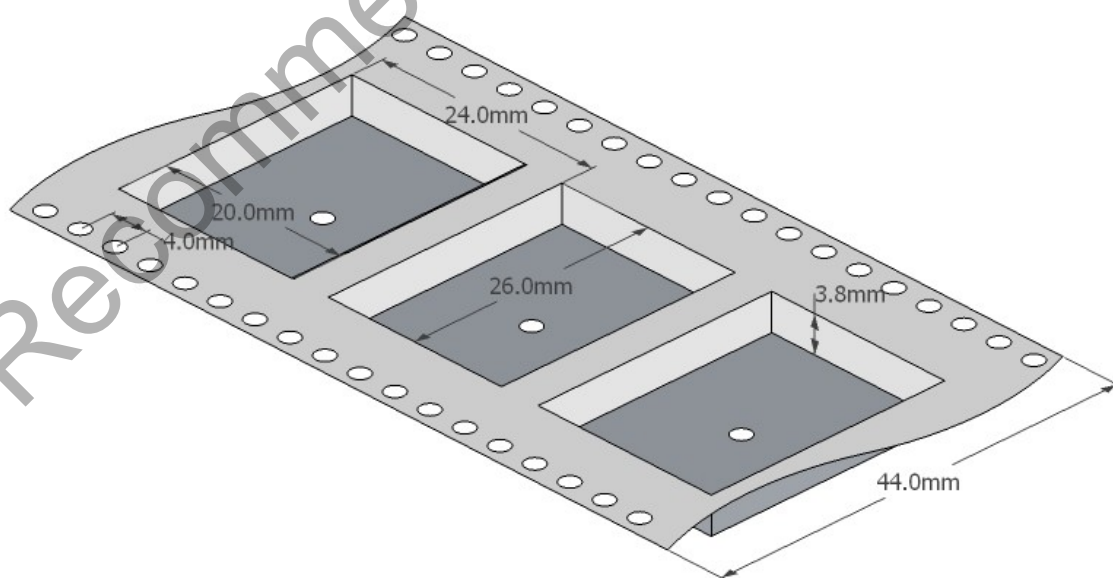

- (2) Cover tape peel force

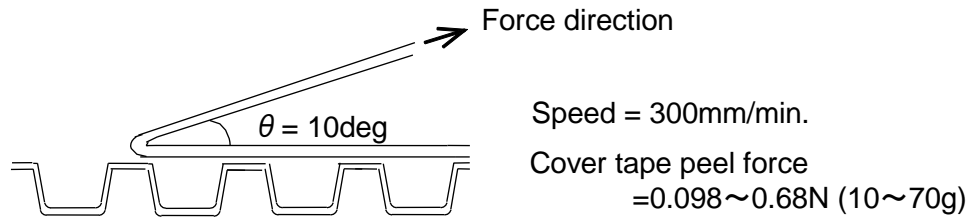

- (3) Empty pockets

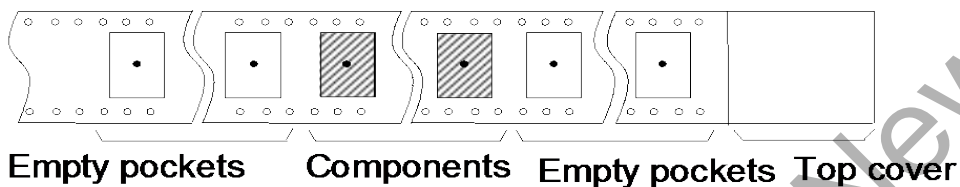

NB: Empty pockets in the populated area will be less than two per reel and those empty pockets will not be consecutive.

17.2 Component Orientation

Top cover tape will not obstruct the carrier tape holes and will not extend beyond the edges of the carrier tape

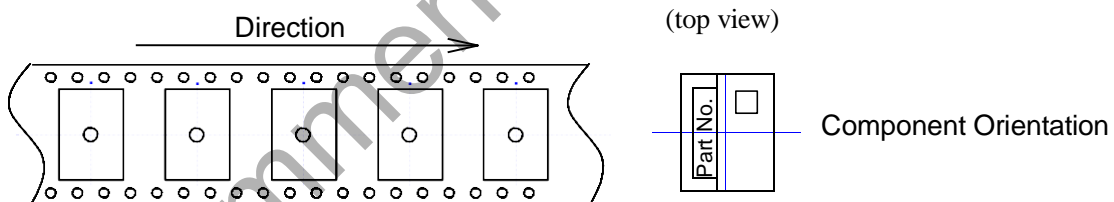

17.3 Reel Dimensions

- (4) Quantity per reel: 600 pieces
- (5) Marking: Part No. / Quantity / Lot No. and manufacturer part# with bar-code will be on the reel

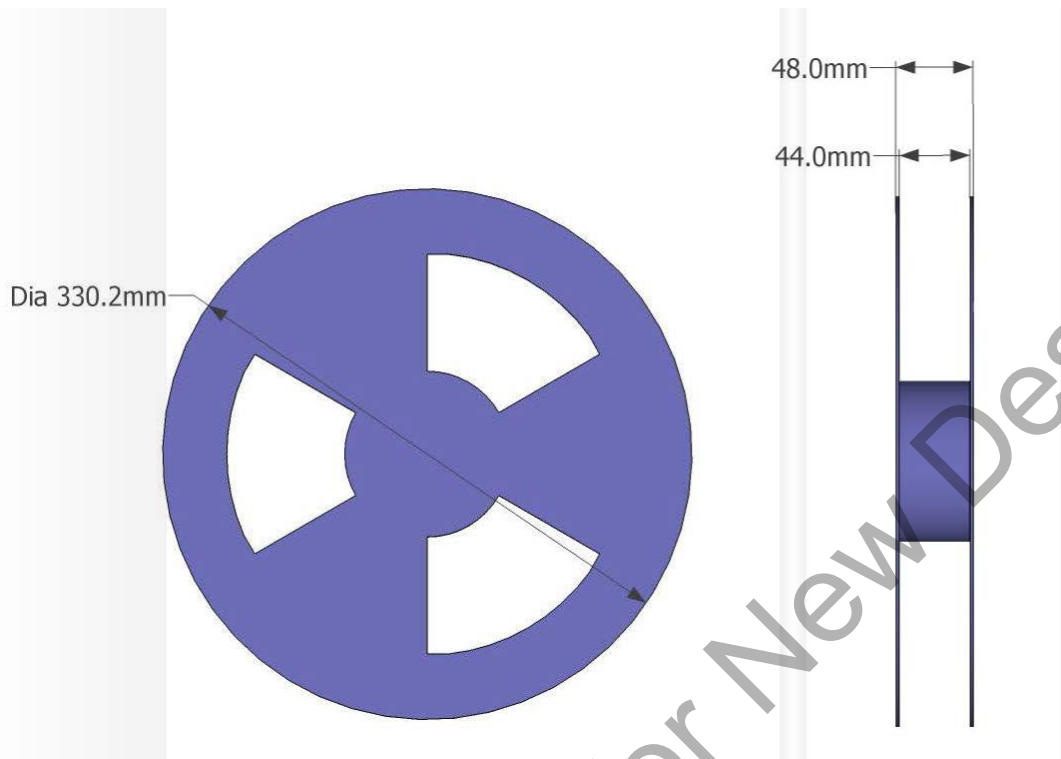

Not Recommended for New Designs

17.4 Packaging

- (6) Each reel will be packed in a hermetically-sealed bag
- (7) Marking: Reel / Antistatic Packaging / Reel Box and outer Box will carry the following label



Imprint	Description
MFG P/N: 99X902DL	Internal use
Lot: 00	Internal use
P/N:ETRX3587	Telegesis Module Order Code.
Quantity:600	Quantity of modules inside the reel/carton
Reel No: 000001	Six digit unique Reel number counting up from 000001
Date:120824	Date Code in the format YYMMDD, e.g. 120824
P/C: ETRX3587-R308	Module product code with reference to firmware/module type selected during ATE. If needed multiline.
2D-Barcode	Information in the 32x32 Datamatrix 2D-Barcode are and identifier "REEL" [5 characters], the reel number [6 characters], the Module Order code [max 18 characters], the quantity [max 4 characters] , the date code in the format Year-Month-Day [6 characters] and the product code [max 40 characters] , all separated by a semicolon.

18 Ordering Information

Ordering/Product Code	Description
ETRX3581 ² ETRX3582 ² ETRX3585 ² ETRX3586 ² ETRX3587 ETRX3588 ²	Telegesis Wireless Mesh Networking Module with Silicon Labs ZigBee Technology: <ul style="list-style-type: none"> • Based on Silicon Labs EM358x SoC • Integrated 2.4GHz Antenna
ETRX3581HR ² ETRX3582HR ² ETRX3585HR ² ETRX3586HR ² ETRX3587HR ETRX3588HR ²	Telegesis Wireless Mesh Networking Module with Silicon Labs ZigBee Technology: <ul style="list-style-type: none"> • Based on Silicon Labs EM358x SoC • U.FL coaxial Antenna Connector
ETRX357DVK	Telegesis Development Kit with: <ul style="list-style-type: none"> • 3 x ETRX3DVK Development Boards • 3 x USB cables • 2 x ETRX357 on carrier boards • 2 x ETRX357HR on carrier boards • 2 x ETRX357-LRS on carrier boards • 2 x ETRX357HR-LRS on carrier boards • 1 x ETRX3USB USB stick • 2 x ½-wave antennae 2 x ¼-wave antennae
ETRX3587 Expansion Pack	<ul style="list-style-type: none"> • 2 x ETRX3587 on carrier boards • 2 x ETRX3587HR on carrier boards • 2 x ETRX3587-LRS on carrier boards • 2 x ETRX3587HR-LRS on carrier boards
Notes:	<ul style="list-style-type: none"> • Customers' PO's must state the Ordering/Product Code. • There is <u>no</u> "blank" version of the ETRX358x modules available.

² MOQ and Lead Time applies. Only stocked modules are ETRX3587 and ETRX3587HR

19 RoHS Declaration

Declaration of environmental compatibility for supplied products:

Hereby we declare based on the declaration of our suppliers that this product does not contain any of the substances which are banned by Directive 2011/65/EU (RoHS2) or if they do, contain a maximum concentration of 0,1% by weight in homogeneous materials for:

- Lead and lead compounds
- Mercury and mercury compounds
- Chromium (VI)
- PBB (polybrominated biphenyl) category
- PBDE (polybrominated biphenyl ether) category

And a maximum concentration of 0.01% by weight in homogeneous materials for:

- Cadmium and cadmium compounds

20 Data Sheet Status

Telegesis (UK) Ltd. reserves the right to change the specification without notice, in order to improve the design and supply the best possible product. Please consult the most recently issued data sheet before initiating or completing a design.

21 Related Documents

- [1] IEEE Standard 802.15.4 –2003 Wireless Medium Access Control (MAC) and Physical Layer (PHY) Specifications for Low-Rate Wireless Personal Area Networks (LR-WPANs)
- [2] Datasheet EM358x, Silicon Labs. (www.silabs.com)
- [3] Datasheet U.FL-Series 2004.2 Hirose Ultra Small Surface Mount Coaxial Connectors - Low Profile 1.9mm or 2.4mm Mated Height
- [4] The ZigBee specification (www.zigbee.org)
- [5] Specification for Antenova Rufa Antenna (www.antenova.com)
- [6] Embedded Antenna design Ltd. (EAD Ltd.) (www.ead-ltd.com)

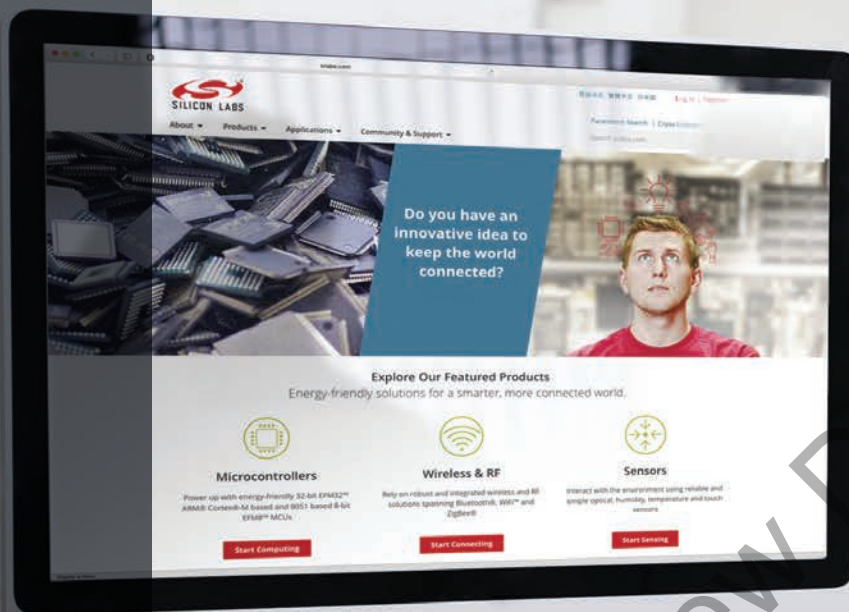

Smart.
Connected.
Energy-Friendly.



Products
www.silabs.com/products



Quality
www.silabs.com/quality



Support and Community
community.silabs.com

Disclaimer

Silicon Labs intends to provide customers with the latest, accurate, and in-depth documentation of all peripherals and modules available for system and software implementers using or intending to use the Silicon Labs products. Characterization data, available modules and peripherals, memory sizes and memory addresses refer to each specific device, and "Typical" parameters provided can and do vary in different applications. Application examples described herein are for illustrative purposes only. Silicon Labs reserves the right to make changes without further notice to the product information, specifications, and descriptions herein, and does not give warranties as to the accuracy or completeness of the included information. Without prior notification, Silicon Labs may update product firmware during the manufacturing process for security or reliability reasons. Such changes will not alter the specifications or the performance of the product. Silicon Labs shall have no liability for the consequences of use of the information supplied in this document. This document does not imply or expressly grant any license to design or fabricate any integrated circuits. The products are not designed or authorized to be used within any FDA Class III devices, applications for which FDA premarket approval is required or Life Support Systems without the specific written consent of Silicon Labs. A "Life Support System" is any product or system intended to support or sustain life and/or health, which, if it fails, can be reasonably expected to result in significant personal injury or death. Silicon Labs products are not designed or authorized for military applications. Silicon Labs products shall under no circumstances be used in weapons of mass destruction including (but not limited to) nuclear, biological or chemical weapons, or missiles capable of delivering such weapons. Silicon Labs disclaims all express and implied warranties and shall not be responsible or liable for any injuries or damages related to use of a Silicon Labs product in such unauthorized applications.

Trademark Information

Silicon Laboratories Inc.®, Silicon Laboratories®, Silicon Labs®, SiLabs® and the Silicon Labs logo®, Bluegiga®, Bluegiga Logo®, ClockBuilder®, CMEMS®, DSPLL®, EFM®, EFM32®, EFR, Ember®, Energy Micro, Energy Micro logo and combinations thereof, "the world's most energy friendly microcontrollers", Ember®, EZLink®, EZRadio®, EZRadioPRO®, Gecko®, Gecko OS, Gecko OS Studio, ISOModem®, Precision32®, ProSLIC®, Simplicity Studio®, SiPHY®, Telegesis, the Telegesis Logo®, USBXpress®, Zentri, the Zentri logo and Zentri DMS, Z-Wave®, and others are trademarks or registered trademarks of Silicon Labs. ARM, CORTEX, Cortex-M3 and THUMB are trademarks or registered trademarks of ARM Holdings. Keil is a registered trademark of ARM Limited. Wi-Fi is a registered trademark of the Wi-Fi Alliance. All other products or brand names mentioned herein are trademarks of their respective holders.



Silicon Laboratories Inc.
400 West Cesar Chavez
Austin, TX 78701
USA

<http://www.silabs.com>