

TOSHIBA BiCD Integrated Circuit Silicon Monolithic

# TB62210FNG

## BiCD Constant-Current Two-Phase Bipolar Stepping Motor Driver IC

The TB62210FNG is a two-phase bipolar stepping motor driver using a PWM chopper.

Fabricated with the BiCD process, the TB62210FNG is rated at 40 V/1.0 A.

The on-chip voltage regulator allows control of a stepping motor with a single  $V_M$  power supply.

### Features

- Bipolar stepping motor driver
- PWM controlled constant-current drive
- Phase in control
- Allows two-phase, 1-2-phase and W1-2 phase excitations.
  
- BiCD process: Uses DMOS FETs as output power transistors.
- High voltage and current : 40 V/1.0 A (absolute maximum ratings)
- Thermal shutdown (TSD), Over current detection (ISD), and Power-on resets (PORs)
- Package: P-HTSSOP24-0508-0.65-001

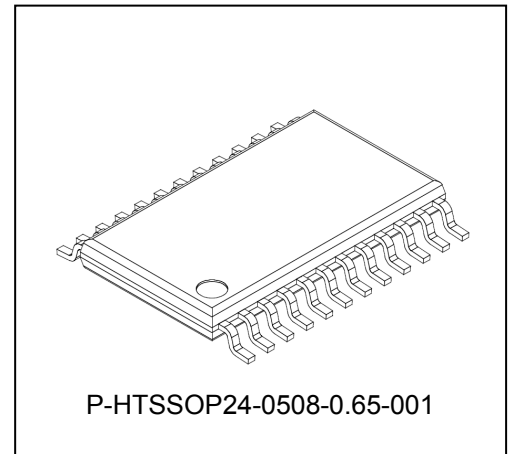

Wight: 0.1 g (typ.)

**Pin Assignment**

(Top View)

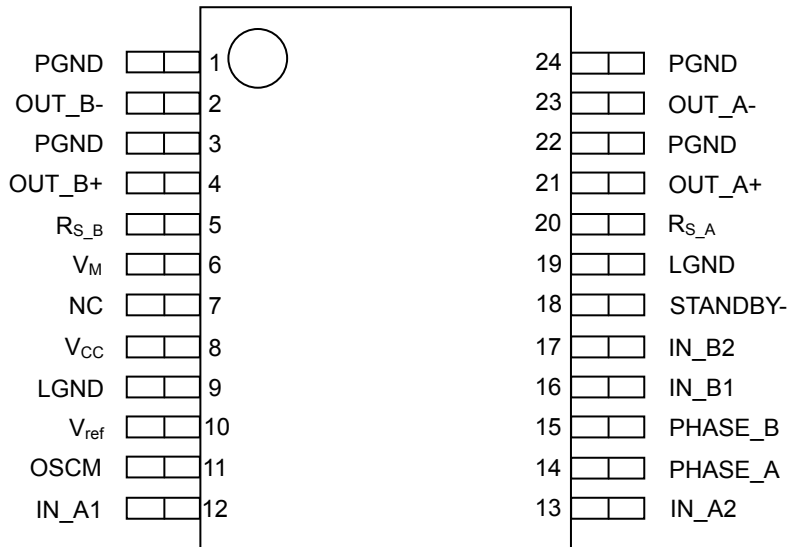

Block Diagram

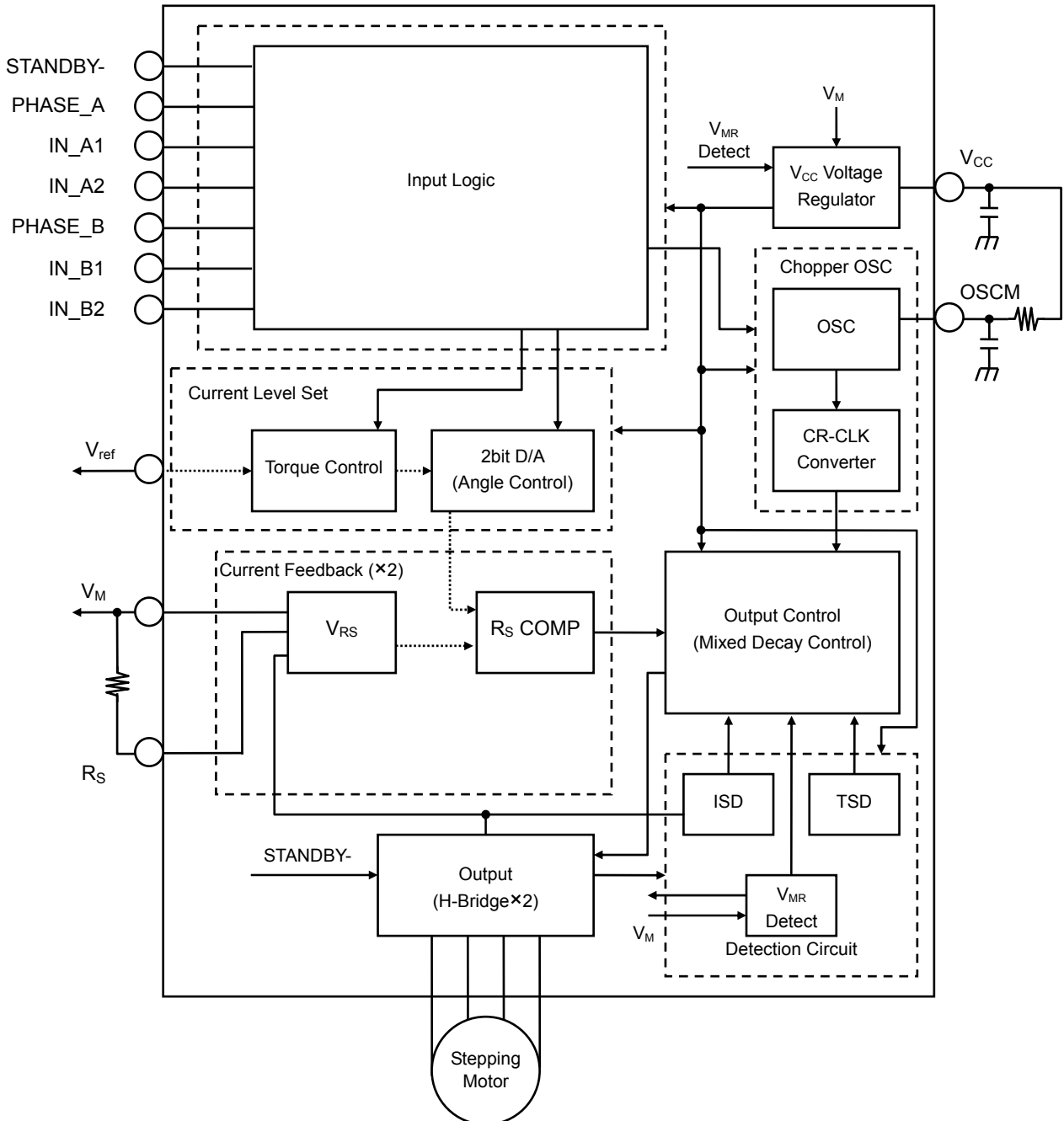

In the block diagram, part of the functional blocks or constants may be omitted or simplified for explanatory purposes.

Note: All the grounding wires of the TB62210FNG must run on the solder mask on the PCB and be externally terminated at only one point. Also, a grounding method should be considered for efficient heat dissipation. Careful attention should be paid to the layout of the output, VM and GND traces, to avoid short-circuits across output pins or to the power supply or ground. If such a short-circuit occurs, the TB62210FNG may be permanently damaged.

Also, utmost care should be taken for pattern designing and implementation of the TB62210FNG since it has the power supply pins (VM, RS, OUT, GND) particularly a large current can run through. If these pins are wired incorrectly, an operation error or even worse a destruction of the TB62210FNG may occur.

The logic input pins must be correctly wired, too; otherwise, the TB62210FNG may be damaged due to a current larger than the specified current running through the IC.

## Pin Function

This table is a function explanation from the terminal number 1 to 24.

Pin No.	Pin Name	Function
1	PGND	Motor power ground
2	OUT_B-	B-phase negative driver output
3	PGND	Motor power ground
4	OUT_B+	B-phase positive driver output
5	R <sub>S_B</sub>	The sink current sensing of B-phase motor coil
6	V <sub>M</sub>	Motor power supply monitor
7	NC	No-connect
8	V <sub>CC</sub>	Smoothing filter for logic power supply
9	LGND	Logic ground
10	V <sub>ref</sub>	Tunes the current level for motor drive
11	OSCM	Oscillator pin for PWM choppers
12	IN_A1	A-phase excitation control input
13	IN_A2	A-phase excitation control input
14	PHASE_A	Current direction signal input for A-phase
15	PHASE_B	Current direction signal input for B-phase
16	IN_B1	B-phase excitation control input
17	IN_B2	B-phase excitation control input
18	STANDBY-	All-function-initializing and Low power dissipation mode
19	LGND	Logic ground
20	R <sub>S_A</sub>	The sink current sensing of A-phase motor coil
21	OUT_A+	A-phase positive driver output
22	PGND	Motor power ground
23	OUT_A-	A-phase negative driver output
24	PGND	Motor power ground

## Output Function Table

### Operation explanation

Input			Output		
PHASE_A PHASE_B	IN_A1 IN_B1	IN_A2 IN_B2	OUT_A+ OUT_B+	OUT_A- OUT_B-	I <sub>OUT</sub>
H	H	H	H	L	100%
	H	L	H	L	71%
	L	H	H	L	38%
	L	L	Outputs disabled	Outputs disabled	0%
L	H	H	L	H	-100%
	H	L	L	H	-71%
	L	H	L	H	-38%
	L	L	Outputs disabled	Outputs disabled	0%

I<sub>OUT</sub>: The current which flows OUT\_A+ (OUT\_B+) to OUT\_A-(OUT\_B-) is defined plus current. The current which flows OUT\_A-(OUT\_B-) to OUT\_A+ (OUT\_B+) is defined minus current.

## Other Functions

Pin Name	H	L	Notes
IN_A1 IN_A2 IN_B1 IN_B2	Outputs enabled	Outputs disabled	When IN_X is asserted Low (where a letter X that indicates a phase), its outputs assume the high-impedance state, regardless of the state of that phase.
PHASE_A PHASE_B	OUT_A+(OUT_B+) : H	OUT_A-(OUT_B-) : H	When PHASE is High, a current normally flows from OUT_A+ (OUT_B+) to OUT_A-(OUT_B-).
STANDBY-	Normal operation mode	Standby mode	When STANDBY- is Low, both the oscillator and output drivers are disabled. The TB62210FNG can not drive a motor.

Input signals to IN\_X and PHASE\_X after the voltage range of the motor being used is attained.

(\*X: A1, A2, B1, B2)

## Protection Features

- (1) Thermal shutdown (TSD)  
The thermal shutdown circuit turns off all the outputs when the junction temperature (T<sub>j</sub>) exceeds 150°C (typ.). The outputs retain the current states.  
The TB62210FNG exits TSD mode and resume normal operation when the TB62210FNG is rebooted or the STANDBY- pin is changed from High to Low and then to High.
- (2) Power-ON-resets (PORs) for V<sub>MR</sub> and V<sub>CCR</sub> (V<sub>M</sub> and V<sub>CC</sub> voltage monitor)  
The outputs are forced off until V<sub>M</sub> and V<sub>CC</sub> reach the rated voltages.
- (3) Over current detection (ISD)  
Each phase has an over current detection circuit, which turns off the corresponding outputs when the output current exceeds the shutdown trip threshold (above the maximum current rating).  
The TB62210FNG exits ISD mode and resume normal operation when the STANDBY- pin is changed from High to Low and then to High.  
This circuit provides protection against a short-circuit by temporarily disabling the device. Important notes on this feature will be provided later.

**Cautions on Over current Detection (ISD) and Thermal Shutdown (TSD)**

- The ISD and TSD circuits are only intended to provide temporary protection against irregular conditions such as an output short-circuit; they do not necessarily guarantee the complete IC safety.
- If the device is used beyond the specified operating ranges, these circuits may not operate properly: then the device may be damaged due to an output short-circuit.
- The ISD circuit is only intended to provide a temporary protection against an output short-circuit. If such a condition persists for a long time, the device may be damaged due to overstress. Over current conditions must be removed immediately by external hardware.

## Absolute Maximum Ratings (T<sub>a</sub> = 25°C)

Characteristics	Symbol	Rating	Unit
Motor power supply	V <sub>M</sub>	40	V
Motor output voltage	V <sub>OUT</sub>	40	V
Motor output current (Note 1)	I <sub>OUT</sub>	1.0	A per phase
Logic power supply	V <sub>CC</sub>	6.0	V
Logic input voltage	V <sub>IN</sub>	6.0	V
V <sub>ref</sub> reference voltage	V <sub>ref</sub>	5.0	V
Power dissipation (Note 2)	P <sub>D</sub>	3.125	W
Operating temperature	T <sub>opr</sub>	-20 to 85	°C
Storage temperature	T <sub>stg</sub>	-55 to 150	°C
Junction temperature	T <sub>J(MAX)</sub>	150	°C

Note 1: Perform thermal calculations for the maximum current value under normal conditions. Use the IC at 0.6 A or less per phase. The current value maybe controlled according to the ambient temperature or board conditions.

Note 2: Mounts on the substrate (T<sub>a</sub> = 25°C)

If T<sub>a</sub> is over 25°C, derating is required at 25mW/°C.

T<sub>a</sub>: Ambient temperature

T<sub>opr</sub>: Ambient temperature while the TB62210FNG is active.

T<sub>J</sub>: Junction temperature while the TB62210FNG is active. The maximum junction temperature is limited by the thermal shutdown (TSD) circuitry.

Because the maximum value of T<sub>J</sub> is 120°C, recommended maximum current usage is below 120°C.

## Absolute Maximum Ratings

The absolute maximum ratings of a semiconductor device are a set of ratings that must not be exceeded, even for a moment. Do not exceed any of these ratings.

Exceeding the rating(s) may cause the device breakdown, damage or deterioration, and may result injury by explosion or combustion.

The value of even one parameter of the absolute maximum ratings should not be exceeded under any circumstances. The TB62210FNG does not have overvoltage protection. Therefore, the device is damaged if a voltage exceeding its rated maximum is applied.

All voltage ratings including supply voltages must always be followed. The other notes and considerations described later should also be referred to.

## Operating Ranges (T<sub>a</sub> = 0 to 85°C)

Characteristics	Symbol	Min	Typ.	Max	Unit	Remarks
Motor power supply	V <sub>M</sub>	10.0	24.0	38.0	V	-
Motor output current	I <sub>OUT</sub>	-	0.6	1.0	A	Per phase (Note 1)
Logic input voltage	V <sub>IN(H)</sub>	2.0	-	5.5	V	Logic high level
	V <sub>IN(L)</sub>	-0.4	-	1.0	V	Logic low level
Chopper frequency	f <sub>chop</sub>	40	-	150	kHz	-
V <sub>ref</sub> reference voltage	V <sub>ref</sub>	GND	-	3.6	V	-
Voltage across the current-sensing resistor pins	V <sub>RS</sub>	0.0	±1.0	±1.5	V	Referenced to the V <sub>M</sub> pin (Note 2)

Note 1: The actual maximum current may be limited by the operating environment (operating conditions such as excitation mode or operating duration, or by the surrounding temperature or board heat dissipation). Determine a realistic maximum current by calculating the heat generated under the operating environment.

Note 2: The maximum V<sub>RS</sub> voltage should not exceed the maximum rated voltage.

## Electrical Characteristics 1 ( $T_a = 25^\circ\text{C}$ , $V_M = 24\text{ V}$ , unless otherwise specified)

Characteristics		Symbol	Test Condition	Min	Typ.	Max	Unit
Digital input voltage	High	$V_{IN(H)}$	Digital input pins (Note)	2	3.3	5.5	V
	Low	$V_{IN(L)}$	Digital input pins (Note)	-0.4	-	1.0	V
Input hysteresis voltage		$V_{IN(HIS)}$	Digital input pins (Note)	100	200	300	mV
Digital input current	High	$I_{IN(H)}$	$V_{IN} = 5\text{ V}$ at the digital input pins under test	35	50	75	$\mu\text{A}$
	Low	$I_{IN(L)}$	$V_{IN} = 0\text{ V}$ at the digital input pins under test	-	-	1	$\mu\text{A}$
Current consumption		$I_{M1}$	Outputs open, STANDBY- = Low	-	2	3	mA
		$I_{M2}$	Outputs open, STANDBY- = High	-	3.5	5	mA
		$I_{M3}$	Outputs open (two-phase excitation)	-	5	7	mA
Output leakage current	High-side	$I_{OH}$	$V_{RS} = V_M = 40\text{ V}$ , $V_{OUT} = 0\text{ V}$	-	-	2	$\mu\text{A}$
	Low-side	$I_{OL}$	$V_{RS} = V_M = V_{OUT} = 40\text{ V}$	2	-	-	$\mu\text{A}$
Chanel-to-channel current differential		$\Delta I_{OUT1}$	Channel-to-channel error	-5	0	5	%
Output current error relative to the predetermined value		$\Delta I_{OUT2}$	$I_{OUT} = 1.0\text{ A}$	-7	0	7	%
$R_S$ pin current		$I_{RS}$	$V_{RS} = V_M = 24\text{ V}$	0	-	10	$\mu\text{A}$
Drain-source ON-resistance of the output transistors (upper and lower sum)		$R_{ON(D-S)}$	$I_{OUT} = 1.0\text{ A}$ , $T_j = 25^\circ\text{C}$	-	1.2	1.5	$\Omega$

Note:  $V_{IN} (L \rightarrow H)$  is defined as the  $V_{IN}$  voltage that causes the outputs to change when a pin under test is gradually raised from 0 V.  $V_{IN} (H \rightarrow L)$  is defined as the  $V_{IN}$  voltage that causes the outputs to change when the pin is then gradually lowered.

The difference between  $V_{IN} (L \rightarrow H)$  and  $V_{IN} (H \rightarrow L)$  is defined as the input hysteresis.



## Electrical Characteristics 2 ( $T_a = 25^\circ\text{C}$ , $V_M = 24\text{ V}$ , unless otherwise specified)

Characteristics	Symbol	Test Condition	Min	Typ.	Max	Unit
$V_{\text{ref}}$ input current	$I_{\text{ref}}$	$V_{\text{ref}} = 3.0\text{ V}$	-	0	1	$\mu\text{A}$
$V_{\text{ref}}$ decay rate	$V_{\text{ref}}(\text{gain})$	$V_{\text{ref}} = 2.0\text{ V}$	1/4.8	1/5.0	1/5.2	-
TSD threshold (Note 1)	$T_{\text{jTSD}}$	-	140	150	170	$^\circ\text{C}$
$V_M$ recovery voltage (Note 2)	$V_{\text{MR}}$	-	7.0	8.0	9.0	V
Supply voltage for internal circuitry (Note 3)	$V_{\text{CC}}$	$I_{\text{CC}} = 5.0\text{ mA}$	4.75	5.00	5.25	V

**Note 1:** Thermal shutdown (TSD) circuitry

When the junction temperature of the device has reached the threshold, the TSD circuitry is tripped, causing the internal reset circuitry to turn off the output transistors.

The TSD circuitry is tripped at a temperature between  $140^\circ\text{C}$  (min) and  $170^\circ\text{C}$  (max). Once tripped, the TSD circuitry keeps the output transistors off until STANDBY- is deasserted High or the IC is restarted. The thermal shutdown circuit is provided to turn off all the outputs when the IC is overheated. For this reason, please avoid using TSD for other purposes.

**Note 2:** The circuit design has been designed so that electromotive force or leak current from signal input does not occur when  $V_M$  voltage is not supplied, even if the logic input signal is input. Even so, regulate logic input signals before resupply of  $V_M$  voltage so that the motor does not operate when voltage is reapplied.

**Note 3:** If the supply voltage for internal circuitry ( $V_{\text{CC}}$ ) is split with an external resistor and used as  $V_{\text{ref}}$  input supply voltage, the accuracy of the output current setting will be at  $\pm 8\%$  when the  $V_{\text{CC}}$  output voltage accuracy and the  $V_{\text{ref}}$  damping ratio accuracy are combined.

## Back-EMF

While a motor is rotating, there is a timing at which power is fed back to the power supply. At that timing, the motor current recirculates back to the power supply due to the effect of the motor back-EMF.

If the power supply does not have enough sink capability, the power supply and output pins of the device might rise above the rated voltages. The magnitude of the motor back-EMF varies with usage conditions and motor characteristics. It must be fully verified that there is no risk that the TB62210FNG or other components will be damaged or fail due to the motor back-EMF.

## IC Mounting

Do not insert devices in the wrong orientation or incorrectly. Otherwise, it may cause the device breakdown, damage and/or deterioration.

## AC Electrical Characteristics ( $T_a = 25^\circ\text{C}$ , $V_M = 24\text{ V}$ , $6.8\text{ mH}/5.7\ \Omega$ )

Characteristics	Symbol	Test Condition	Min	Typ.	Max	Unit
Phase frequency	$f_{\text{PHASE}}$	$f_{\text{CR}} = 1600\text{ kHz}$	-	-	400	kHz
Minimum phase pulse width	$t_{\text{PHASE}}$	-	100	-	-	ns
	$t_{\text{wp}}$	-	50	-	-	ns
	$t_{\text{wn}}$	-	50	-	-	ns
Output transistor switching characteristics	$t_r$	-	150	200	250	ns
	$t_f$	-	100	150	200	ns
Blanking time for current spike prevention	$t_{\text{BLANK}}$	$I_{\text{OUT}} = 1.0\text{ A}$	200	300	500	ns
OSCM oscillation frequency	$f_{\text{CR}}$	$C_{\text{OSC}} = 270\text{ pF}$ , $R_{\text{OSC}} = 3.6\text{ k}\Omega$	1200	1600	2000	kHz
Chopper frequency range	$f_{\text{chop (RANGE)}}$	$V_M = 24\text{ V}$ , outputs enabled ACTIVE ( $I_{\text{OUT}} = 1.0\text{ A}$ )	40	-	150	kHz
Predefined chopper frequency	$f_{\text{chop}}$	Outputs enabled ACTIVE ( $I_{\text{OUT}} = 1.0\text{ A}$ ), $f_{\text{CR}} = 1600\text{ kHz}$	-	100	-	kHz

### Timing Charts of Output Transistors Switching

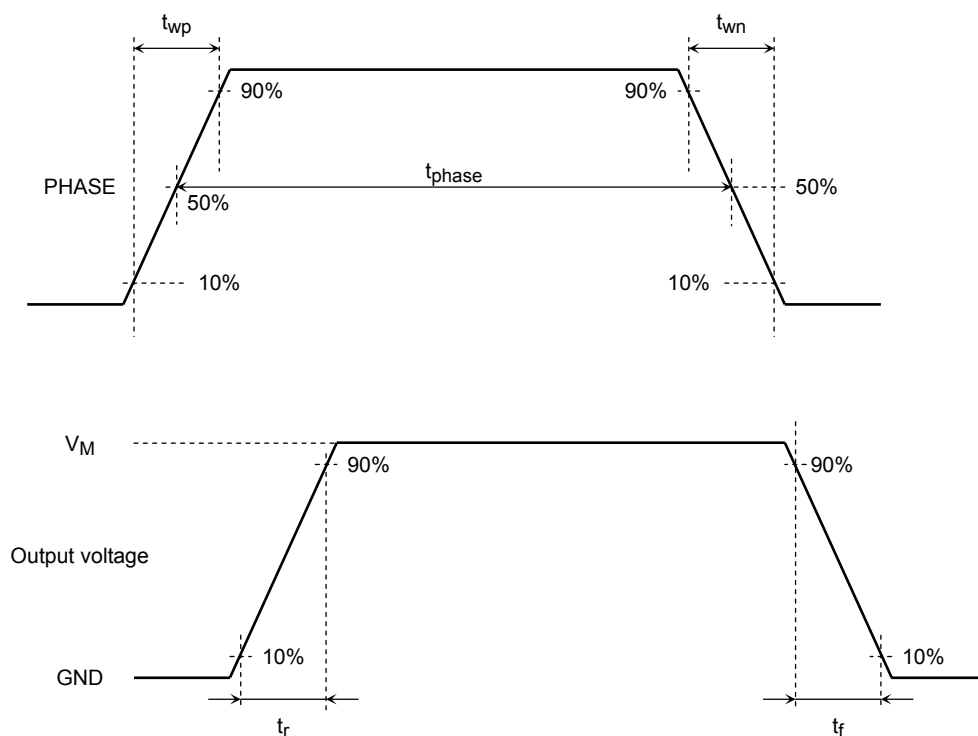

The timing charts may be simplified for explanatory purpose.

## Calculation of the Predefined Output Current

For PWM constant-current control, the TB62210FNG uses a clock generated by the CR oscillator. The peak output current can be set via the current-sensing resistor ( $R_{RS}$ ) and the reference voltage ( $V_{ref}$ ), as follows:

$$I_{OUT} = (1 / 5) \times V_{ref}[V] \times (1 / R_{RS}[\Omega])$$

where, 1/5 is the  $V_{ref}$  decay rate,  $V_{ref(gain)}$ . For the value of  $V_{ref(gain)}$ , see the Electrical Characteristics table.

For example, when  $V_{ref} = 0.88$  V, to generate an output current ( $I_{OUT}$ ) of 0.8 A,  $R_{RS}$  is calculated as:

$$R_{RS} = (V_{ref} / 5) / I_{OUT} = (0.88 / 5) / 0.8 = 0.22\Omega (\geq 0.5W)$$

Phase Sequences  
2-Phase Excitation Mode

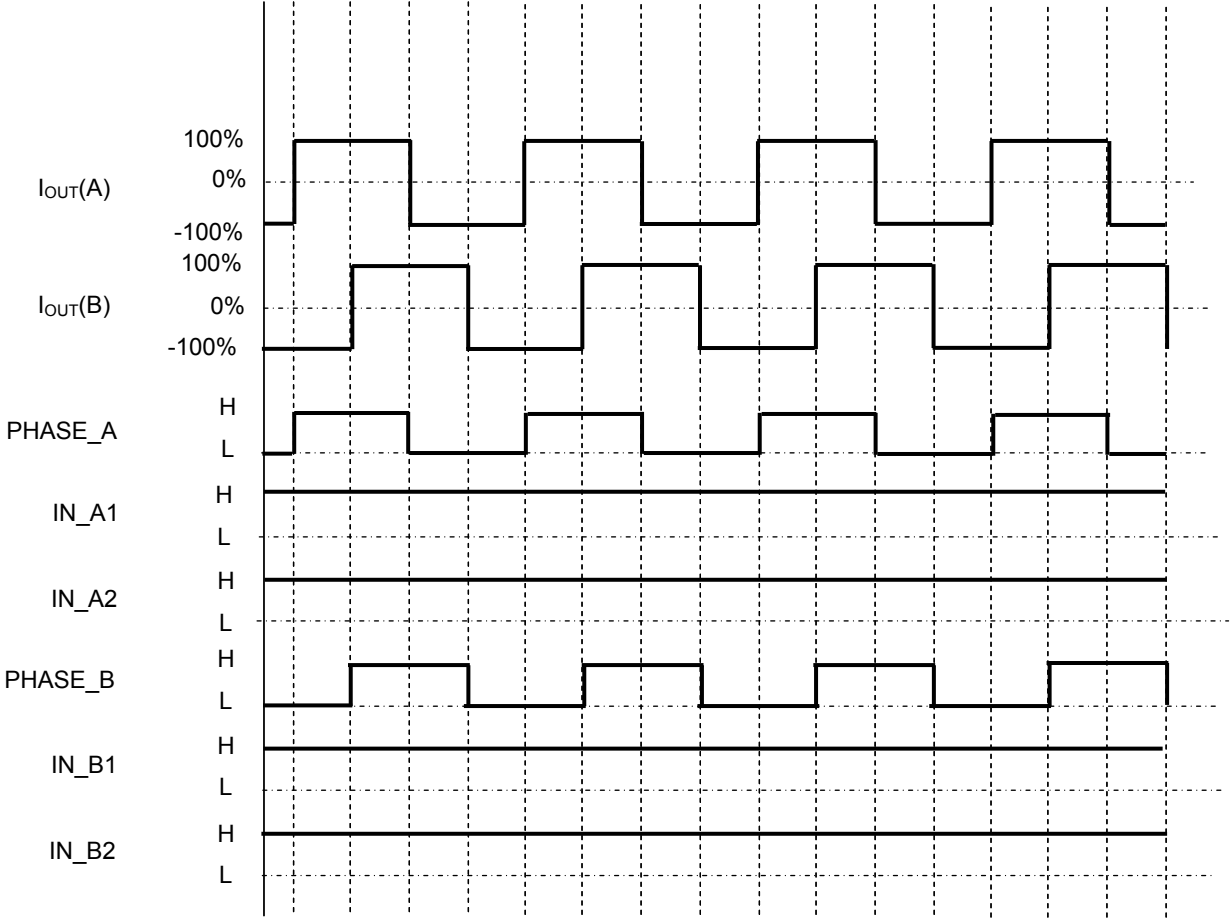

Timing charts may be simplified for explanatory purposes.

1-2-Phase Excitation

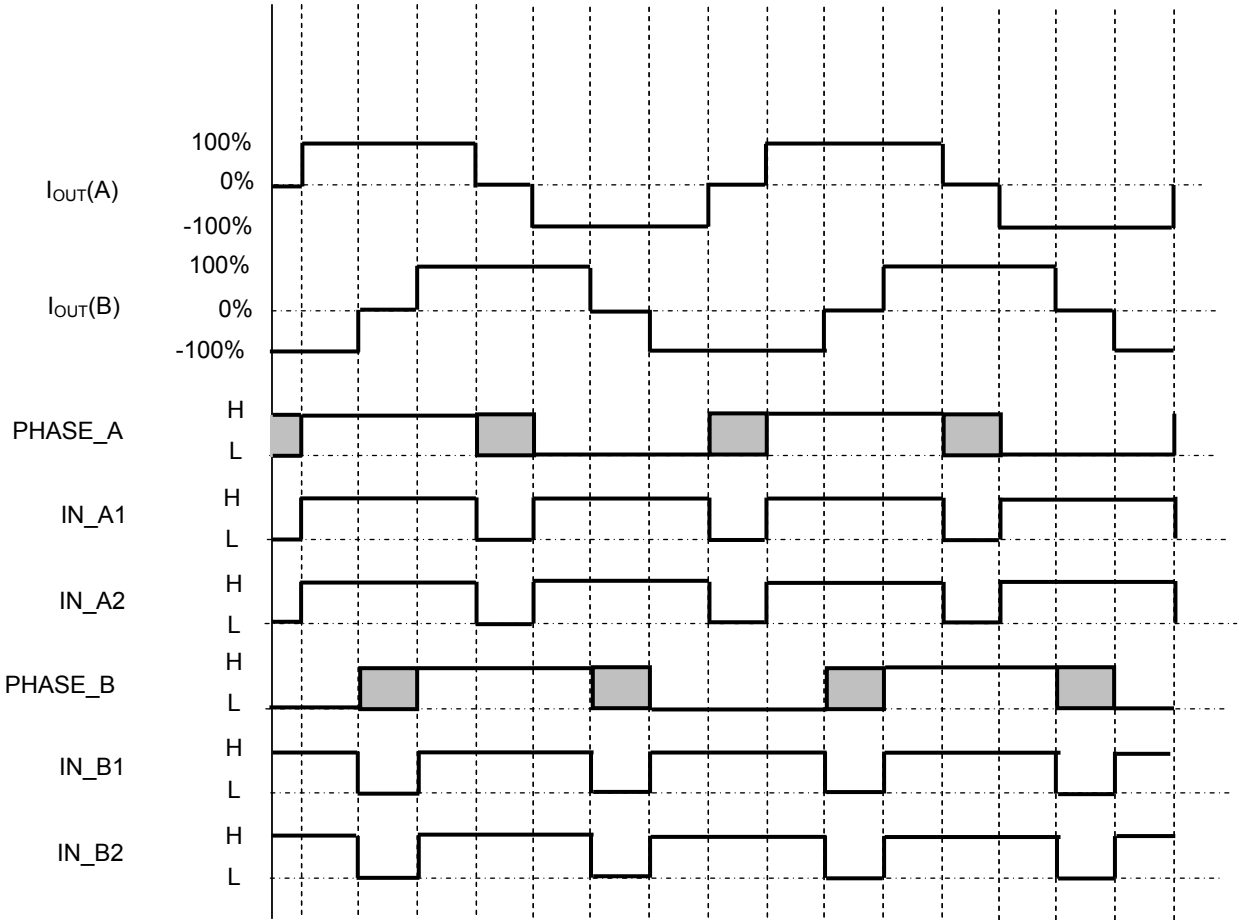

Timing charts may be simplified for explanatory purposes.

## W1-2-Phase Excitation

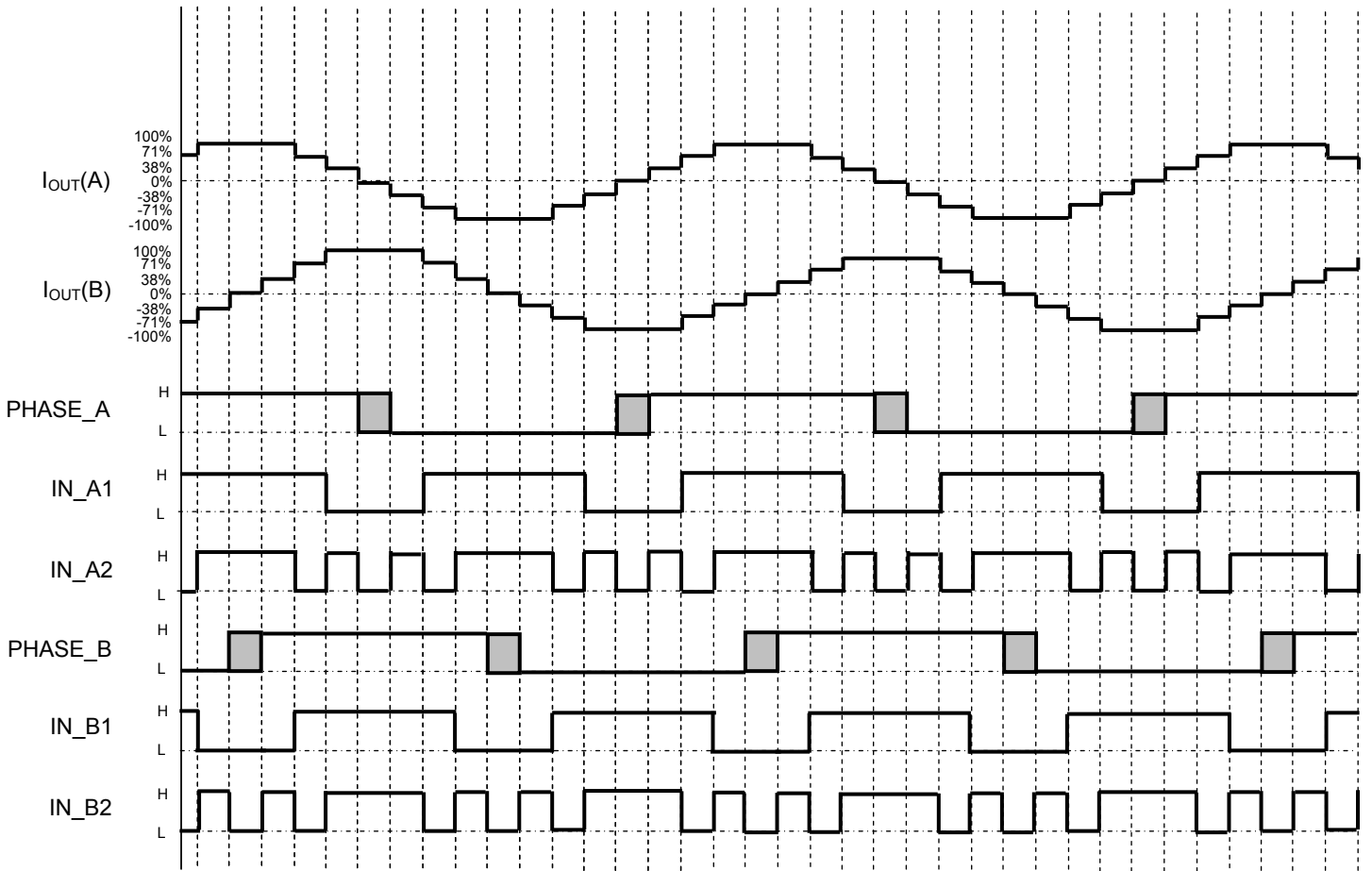

Timing charts may be simplified for explanatory purposes.

**Calculation of the OSCM oscillation frequency (chopper reference frequency)**

The OSCM oscillating frequency can be approximated using the following equation:

$$f_{CR} = 1 / [0.56 \times C_{OSC} \times (R_{OSC} + 500)]$$

Where:

$C_{OSC}$  = Capacitor capacity

$R_{OSC}$  = Resistance

Assigning  $C_{OSC} = 270 \times 10^{-12}$  [F],  $R_{OSC} = 3600$  [ $\Omega$ ] to get:

$$f_{CR} = 1.61 \times 10^6 = 1.6 \text{ MHz}$$

At this time, the chopping frequency  $f_{chop}$  is calculated as follows:

$$f_{chop} = f_{CR}/16 = 100 \text{ kHz}$$

**Application Circuit Example**

The values shown in the following figure are typical values. For input conditions, see Operating Ranges.

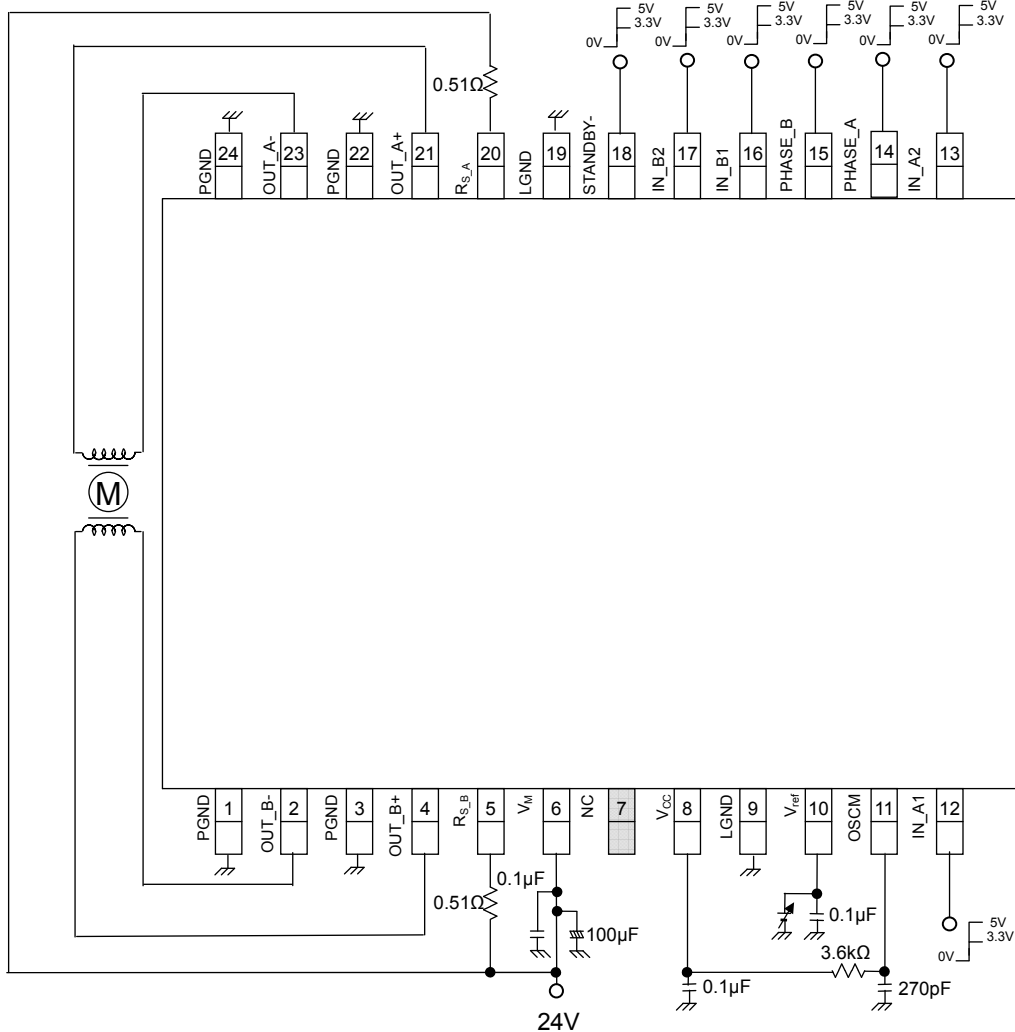

Note: I will recommend the addition of capacitor if necessary. The GND wiring must become one point as much as possible-earth.

The example of applied circuit is an example of the reference, and do an enough evaluation before the mass production design, please.

Moreover, it is not the one to permit the use of the industrial property.

The IC may be destroyed due to short circuit between output pins, an output pin and the VDD pin, or an output pin and the GND pin. Design an output line, VM line and GND line with great care. Also a low-withstand-voltage device may be destroyed when mounted in the wrong orientation, which causes high-withstanding voltage to be applied to the device.



**Package Dimensions**

P-HTSSOP24-0508-0.65-001

“Unit : mm”

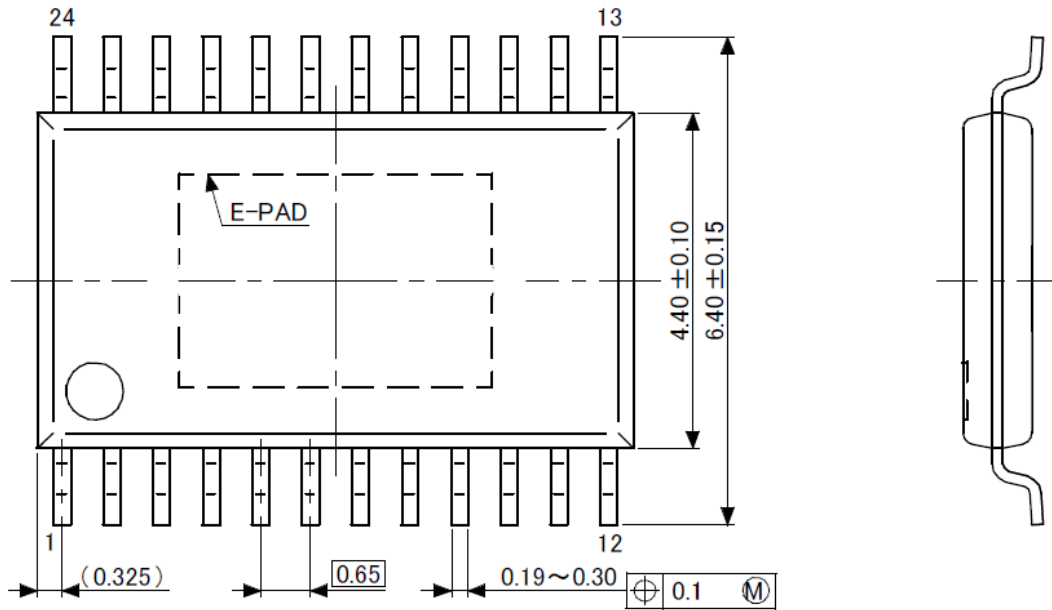

The heat sink is located on the back side and has dimensions of 2.85 mm × 4.05 mm.

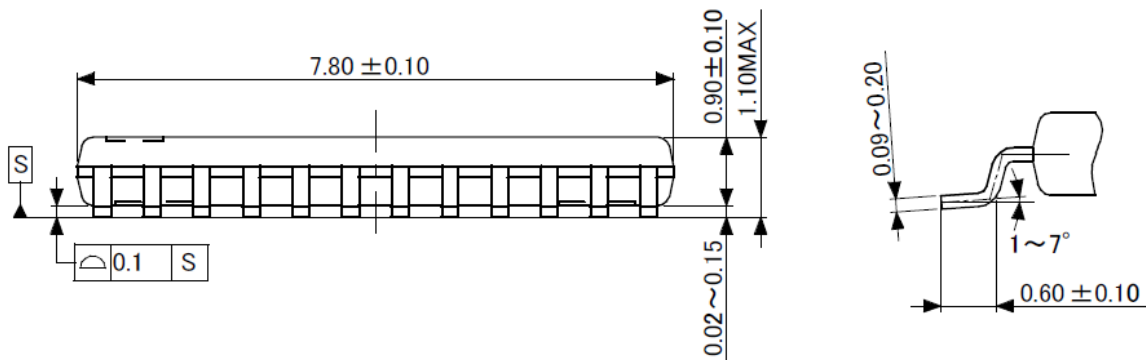

**Notes on Contents****Block Diagrams**

Some of the functional blocks, circuits, or constants in the block diagram may be omitted or simplified for explanatory purposes.

**Timing Charts**

Timing charts may be simplified for explanatory purposes.

**Application Circuits**

The application circuits shown in this document are provided for reference purposes only. Thorough evaluation is required, especially at the mass production design stage.

Toshiba does not grant any license to any industrial property rights by providing these examples of application circuits.

## IC Usage Considerations

### Notes on handling of ICs

- (1) The absolute maximum ratings of a semiconductor device are a set of ratings that must not be exceeded, even for a moment. Do not exceed any of these ratings.  
Exceeding the rating(s) may cause the device breakdown, damage or deterioration, and may result injury by explosion or combustion.
- (2) Use an appropriate power supply fuse to ensure that a large current does not continuously flow in case of over current and/or IC failure. The IC will fully break down when used under conditions that exceed its absolute maximum ratings, when the wiring is routed improperly or when an abnormal pulse noise occurs from the wiring or load, causing a large current to continuously flow and the breakdown can lead smoke or ignition. To minimize the effects of the flow of a large current in case of breakdown, appropriate settings, such as fuse capacity, fusing time and insertion circuit location, are required.
- (3) If your design includes an inductive load such as a motor coil, incorporate a protection circuit into the design to prevent device malfunction or breakdown caused by the current resulting from the inrush current at power ON or the negative current resulting from the back electromotive force at power OFF. IC breakdown may cause injury, smoke or ignition.  
Use a stable power supply with ICs with built-in protection functions. If the power supply is unstable, the protection function may not operate, causing IC breakdown. IC breakdown may cause injury, smoke or ignition.
- (4) Do not insert devices in the wrong orientation or incorrectly.  
Make sure that the positive and negative terminals of power supplies are connected properly.  
Otherwise, the current or power consumption may exceed the absolute maximum rating, and exceeding the rating(s) may cause the device breakdown, damage or deterioration, and may result injury by explosion or combustion.  
In addition, do not use any device that is applied the current with inserting in the wrong orientation or incorrectly even just one time.
- (5) Carefully select external components (such as inputs and negative feedback capacitors) and load components (such as speakers), for example, power amp and regulator.  
If there is a large amount of leakage current such as input or negative feedback condenser, the IC output DC voltage will increase. If this output voltage is connected to a speaker with low input withstand voltage, over current or IC failure can cause smoke or ignition. (The over current can cause smoke or ignition from the IC itself.) In particular, please pay attention when using a Bridge Tied Load (BTL) connection type IC that inputs output DC voltage to a speaker directly.

**Points to remember on handling of ICs**

- (1) **Over current Detection Circuit**  
Over current detection circuits (referred to as current limiter circuits) do not necessarily protect ICs under all circumstances. If the Over current detection circuits operate against the over current, clear the over current status immediately.  
Depending on the method of use and usage conditions, such as exceeding absolute maximum ratings can cause the over current detection circuit to not operate properly or IC breakdown before operation. In addition, depending on the method of use and usage conditions, if over current continues to flow for a long time after operation, the IC may generate heat resulting in breakdown.
- (2) **Thermal Shutdown Circuit**  
Thermal shutdown circuits do not necessarily protect ICs under all circumstances. If the thermal shutdown circuits operate against the over temperature, clear the heat generation status immediately.  
Depending on the method of use and usage conditions, such as exceeding absolute maximum ratings can cause the thermal shutdown circuit to not operate properly or IC breakdown before operation.
- (3) **Heat Radiation Design**  
In using an IC with large current flow such as power amp, regulator or driver, please design the device so that heat is appropriately radiated, not to exceed the specified junction temperature (T<sub>J</sub>) at any time and condition. These ICs generate heat even during normal use. An inadequate IC heat radiation design can lead to decrease in IC life, deterioration of IC characteristics or IC breakdown. In addition, please design the device taking into consideration the effect of IC heat radiation with peripheral components.
- (4) **Back-EMF**  
When a motor rotates in the reverse direction, stops or slows down abruptly, a current flow back to the motor's power supply due to the effect of back-EMF. If the current sink capability of the power supply is small, the device's motor power supply and output pins might be exposed to conditions beyond maximum ratings. To avoid this problem, take the effect of back-EMF into consideration in system design.

## RESTRICTIONS ON PRODUCT USE

- Toshiba Corporation, and its subsidiaries and affiliates (collectively "TOSHIBA"), reserve the right to make changes to the information in this document, and related hardware, software and systems (collectively "Product") without notice.
- This document and any information herein may not be reproduced without prior written permission from TOSHIBA. Even with TOSHIBA's written permission, reproduction is permissible only if reproduction is without alteration/omission.
- Though TOSHIBA works continually to improve Product's quality and reliability, Product can malfunction or fail. Customers are responsible for complying with safety standards and for providing adequate designs and safeguards for their hardware, software and systems which minimize risk and avoid situations in which a malfunction or failure of Product could cause loss of human life, bodily injury or damage to property, including data loss or corruption. Before customers use the Product, create designs including the Product, or incorporate the Product into their own applications, customers must also refer to and comply with (a) the latest versions of all relevant TOSHIBA information, including without limitation, this document, the specifications, the data sheets and application notes for Product and the precautions and conditions set forth in the "TOSHIBA Semiconductor Reliability Handbook" and (b) the instructions for the application with which the Product will be used with or for. Customers are solely responsible for all aspects of their own product design or applications, including but not limited to (a) determining the appropriateness of the use of this Product in such design or applications; (b) evaluating and determining the applicability of any information contained in this document, or in charts, diagrams, programs, algorithms, sample application circuits, or any other referenced documents; and (c) validating all operating parameters for such designs and applications. **TOSHIBA ASSUMES NO LIABILITY FOR CUSTOMERS' PRODUCT DESIGN OR APPLICATIONS.**
- Product is intended for use in general electronics applications (e.g., computers, personal equipment, office equipment, measuring equipment, industrial robots and home electronics appliances) or for specific applications as expressly stated in this document. Product is neither intended nor warranted for use in equipment or systems that require extraordinarily high levels of quality and/or reliability and/or a malfunction or failure of which may cause loss of human life, bodily injury, serious property damage or serious public impact ("Unintended Use"). Unintended Use includes, without limitation, equipment used in nuclear facilities, equipment used in the aerospace industry, medical equipment, equipment used for automobiles, trains, ships and other transportation, traffic signaling equipment, equipment used to control combustions or explosions, safety devices, elevators and escalators, devices related to electric power, and equipment used in finance-related fields. Do not use Product for Unintended Use unless specifically permitted in this document.
- Do not disassemble, analyze, reverse-engineer, alter, modify, translate or copy Product, whether in whole or in part.
- Product shall not be used for or incorporated into any products or systems whose manufacture, use, or sale is prohibited under any applicable laws or regulations.
- The information contained herein is presented only as guidance for Product use. No responsibility is assumed by TOSHIBA for any infringement of patents or any other intellectual property rights of third parties that may result from the use of Product. No license to any intellectual property right is granted by this document, whether express or implied, by estoppel or otherwise.
- **ABSENT A WRITTEN SIGNED AGREEMENT, EXCEPT AS PROVIDED IN THE RELEVANT TERMS AND CONDITIONS OF SALE FOR PRODUCT, AND TO THE MAXIMUM EXTENT ALLOWABLE BY LAW, TOSHIBA (1) ASSUMES NO LIABILITY WHATSOEVER, INCLUDING WITHOUT LIMITATION, INDIRECT, CONSEQUENTIAL, SPECIAL, OR INCIDENTAL DAMAGES OR LOSS, INCLUDING WITHOUT LIMITATION, LOSS OF PROFITS, LOSS OF OPPORTUNITIES, BUSINESS INTERRUPTION AND LOSS OF DATA, AND (2) DISCLAIMS ANY AND ALL EXPRESS OR IMPLIED WARRANTIES AND CONDITIONS RELATED TO SALE, USE OF PRODUCT, OR INFORMATION, INCLUDING WARRANTIES OR CONDITIONS OF MERCHANTABILITY, FITNESS FOR A PARTICULAR PURPOSE, ACCURACY OF INFORMATION, OR NONINFRINGEMENT.**
- Do not use or otherwise make available Product or related software or technology for any military purposes, including without limitation, for the design, development, use, stockpiling or manufacturing of nuclear, chemical, or biological weapons or missile technology products (mass destruction weapons). Product and related software and technology may be controlled under the Japanese Foreign Exchange and Foreign Trade Law and the U.S. Export Administration Regulations. Export and re-export of Product or related software or technology are strictly prohibited except in compliance with all applicable export laws and regulations.
- Please contact your TOSHIBA sales representative for details as to environmental matters such as the RoHS compatibility of Product. Please use Product in compliance with all applicable laws and regulations that regulate the inclusion or use of controlled substances, including without limitation, the EU RoHS Directive. TOSHIBA assumes no liability for damages or losses occurring as a result of noncompliance with applicable laws and regulations.