



SMT power inductors

Size 6.3 × 6.3 × 3.0 (mm)

Series/Type: **B82462G4**

Date: September 2019

SMD
Rated inductance 0.82 ... 1000 μ H
Rated current 0.16 ... 3.45 A

Construction

- Ferrite core
- Magnetically shielded
- Winding: enamel copper wire
- Winding welded to terminals

Features

- Temperature range up to +150 °C
- High rated current, low DC resistance
- Suitable for lead-free reflow soldering as referenced in JEDEC J-STD 020D
- Qualified to AEC-Q200
- RoHS-compatible

Applications

- Filtering of supply voltages
- Coupling, decoupling
- DC/DC converters
- Automotive electronics
- Industrial electronics

Terminals

- Base material CuSn6
- Layer composition Ag, Sn (lead-free)¹⁾
- Electro-plated

Marking

- Marking on component:
Manufacturer, L value (nH, coded),
L tolerance (coded), manufacturing date (YWWD)
- Minimum data on reel:
Manufacturer, ordering code,
L value, quantity, date of packing

Delivery mode and packing unit

- 12-mm blister tape, wound on 330-mm \varnothing reel
- Packing unit: 2500 pcs./reel

1) Ni-barrier-plated terminals on request (B82462G4*050).

SMD

Dimensional drawing and layout recommendation

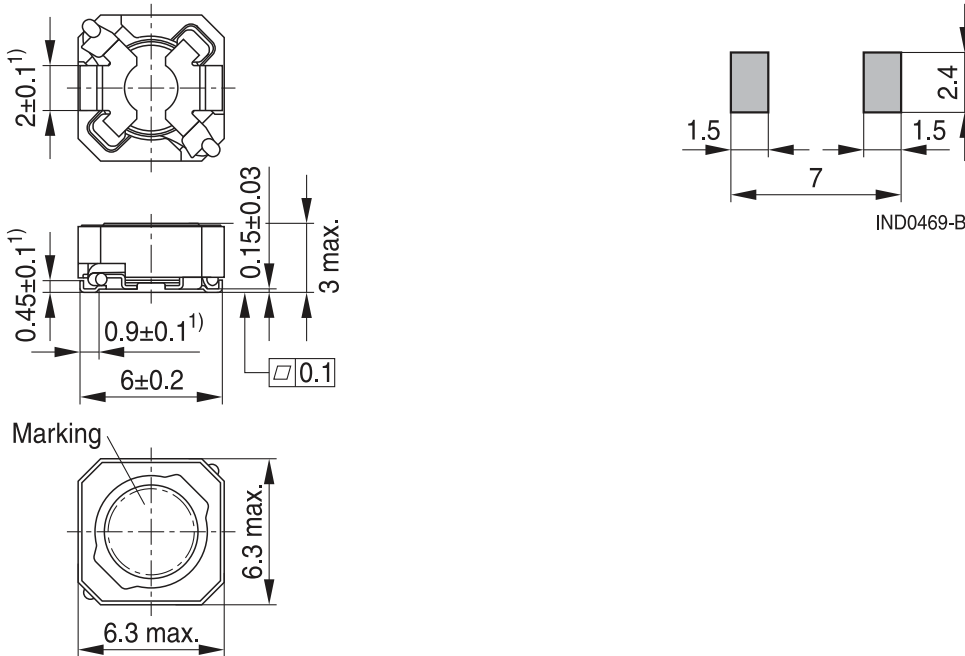

1) Soldering area

IND1118-C

Dimensions in mm

Taping and packing

Blister tape

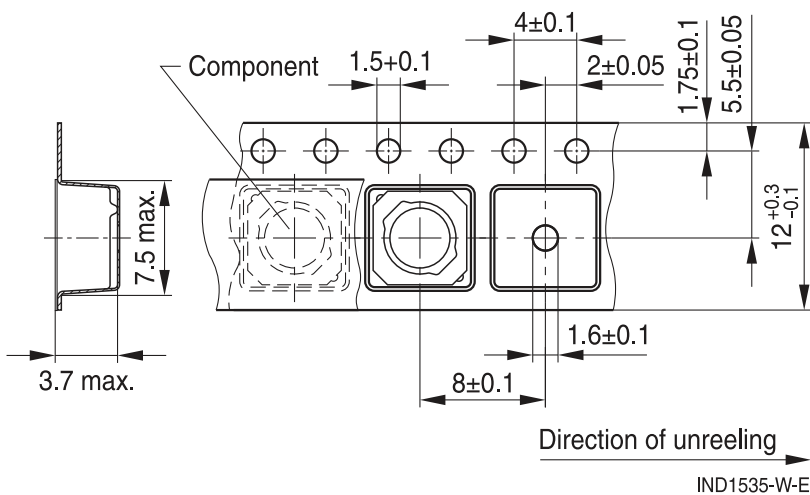

IND1535-W-E

Reel

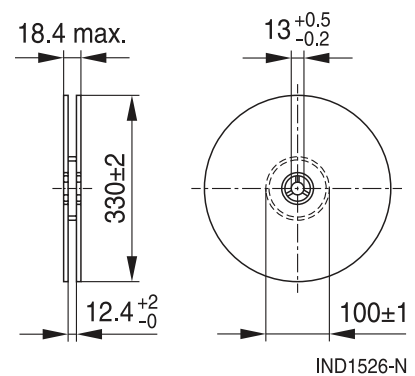

IND1526-N

Dimensions in mm

SMD
Technical data and measuring conditions

Rated inductance L_R	Measured with impedance analyzer Agilent 4294A or equivalent at frequency f_L , 0.1 V, +20 °C
Operating temperature range	-55 ... + 150 °C
Rated current $I_{temp,typ}$	Max. permissible DC with temperature increase of ≤ 40 K at +85 °C
Saturation current I_{sat}	Max. permissible DC with inductance decrease $\Delta L/L_0$ of approx. 10%
DC resistance R_{max}	Measured at +20 °C
Solderability (lead-free)	Dip and look method Sn95.5Ag3.8Cu0.7: +(245 \pm 5) °C, (5 \pm 0.3) s Wetting of soldering area $\geq 90\%$ (based on IEC 60068-2-58)
Resistance to soldering heat	+260 °C, 40 s as referenced in JEDEC J-STD 020D
Climatic category	55/150/56 (to IEC 60068-1)
Storage conditions	Mounted: -55 °C ... +150 °C Packaged: -25 °C ... +40 °C, $\leq 75\%$ RH
Weight	Approx. 0.4 g

SMD
Characteristics and ordering codes

L_R μH	Tolerance	f_L MHz	$I_{\text{sat,typ}}$ A	$I_{\text{sat,min}}$ A	$I_{\text{temp,typ}}$ A	R_{max} Ω	R_{typ} Ω	Ordering code
0.82	$\pm 20\% \triangleq M$	0.1	5.10	4.45	3.45	0.0150	0.0136	B82462G4821M000
1.0		0.1	4.70	4.40	3.40	0.0160	0.0159	B82462G4102M000
1.2		0.1	4.20	3.90	3.25	0.0170	0.0161	B82462G4122M000
1.5		0.1	3.70	3.60	3.10	0.0200	0.0180	B82462G4152M000
2.2		0.1	3.05	2.60	2.55	0.0250	0.0215	B82462G4222M000
3.3		0.1	2.70	2.10	2.30	0.0310	0.0251	B82462G4332M000
4.7		0.1	2.20	1.80	2.00	0.0400	0.0350	B82462G4472M000
6.8		0.1	1.70	1.50	1.65	0.0500	0.0463	B82462G4682M000
10		0.1	1.45	1.30	1.50	0.0620	0.0580	B82462G4103M000
15		0.1	1.20	1.05	1.25	0.0970	0.0910	B82462G4153M000
22		0.1	0.93	0.85	1.05	0.1500	0.1350	B82462G4223M000
33		0.1	0.82	0.72	0.85	0.2300	0.2010	B82462G4333M000
47		0.1	0.68	0.60	0.75	0.3100	0.2860	B82462G4473M000
68		0.1	0.54	0.50	0.65	0.4100	0.3720	B82462G4683M000
100		0.1	0.57	0.42	0.53	0.5800	0.5610	B82462G4104M000
150		0.1	0.37	0.33	0.38	1.0500	0.8460	B82462G4154M000
220		0.1	0.28	0.28	0.35	1.3500	1.2600	B82462G4224M000
330		0.1	0.27	0.22	0.27	2.3000	1.8370	B82462G4334M000
470		0.1	0.23	0.18	0.24	2.7000	2.5000	B82462G4474M000
680		0.1	0.18	0.15	0.20	4.0500	3.7000	B82462G4684M000
1000		0.1	0.15	0.13	0.16	6.0000	5.6000	B82462G4105M000

1) For Ni-barrier-plated terminals replace the last two digits "00" by "50".

SMD

Impedance $|Z|$ versus frequency f
 measured with impedance analyzer
 Agilent 4294A, typical values at +20 °C

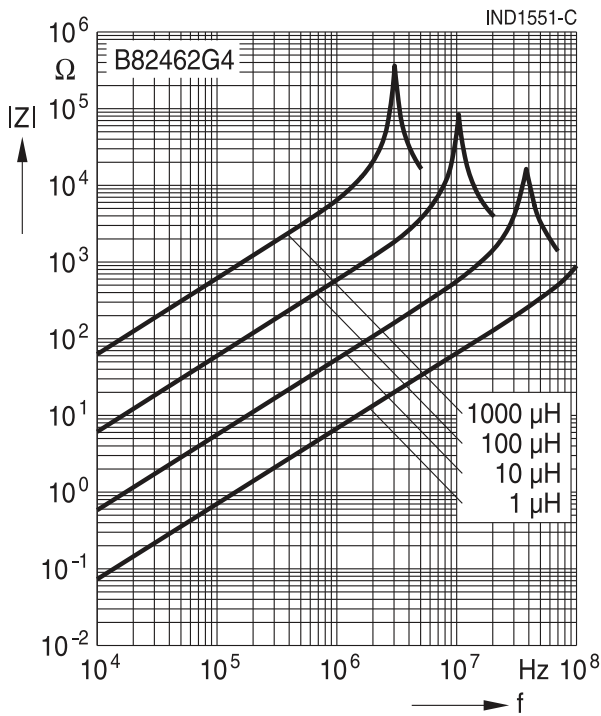

Inductance L versus DC load current I_{DC}
 measured with LCR meter Agilent 4285A,
 typical values at +20 °C

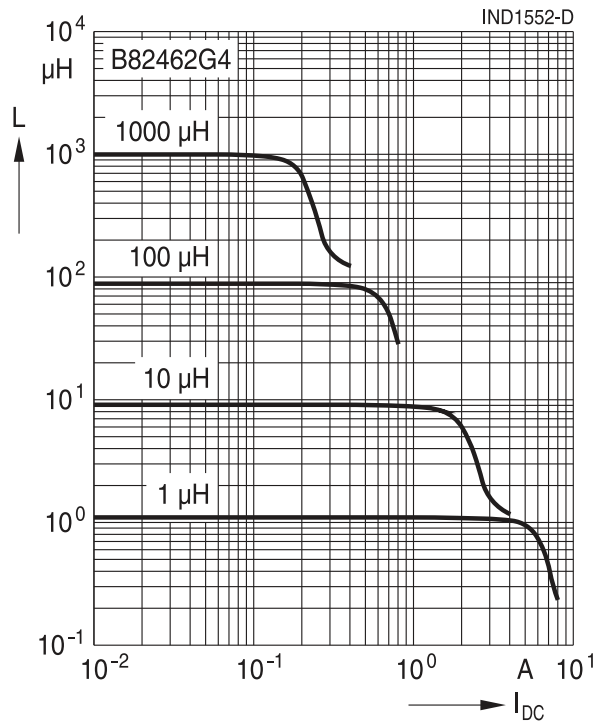

Current derating I_{op}/I_R
versus ambient temperature T_A
 (rated temperature $T_R = +85$ °C)

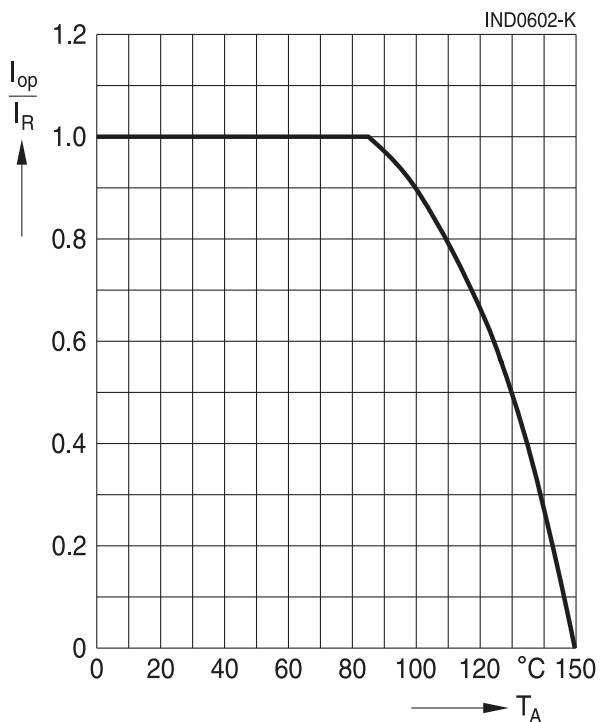

Cautions and warnings

- Please note the recommendations in our Inductors data book (latest edition) and in the data sheets.
 - Particular attention should be paid to the derating curves given there.
 - The soldering conditions should also be observed. Temperatures quoted in relation to wave soldering refer to the pin, not the housing.
- If the components are to be washed varnished it is necessary to check whether the washing varnish agent that is used has a negative effect on the wire insulation, any plastics that are used, or on glued joints. In particular, it is possible for washing varnish agent residues to have a negative effect in the long-term on wire insulation.
Washing processes may damage the product due to the possible static or cyclic mechanical loads (e.g. ultrasonic cleaning). They may cause cracks to develop on the product and its parts, which might lead to reduced reliability or lifetime.
- The following points must be observed if the components are potted in customer applications:
 - Many potting materials shrink as they harden. They therefore exert a pressure on the plastic housing or core. This pressure can have a deleterious effect on electrical properties, and in extreme cases can damage the core or plastic housing mechanically.
 - It is necessary to check whether the potting material used attacks or destroys the wire, wire insulation, plastics or glue.
 - The effect of the potting material can change the high-frequency behaviour of the components.
 - Many coating materials have a negative effect (chemically and mechanically) on the winding wires, insulation materials and connecting points. Customers are always obligated to determine whether and to what extent their coating materials influence the component.
Customers are responsible and bear all risk for the use of the coating material. TDK Electronics does not assume any liability for failures of our components that are caused by the coating material.
- Ceramics / ferrites are sensitive to direct impact. This can cause the core material to flake, or lead to breakage of the core.
- Even for customer-specific products, conclusive validation of the component in the circuit can only be carried out by the customer.

Display of ordering codes for TDK Electronics products

The ordering code for one and the same product can be represented differently in data sheets, data books, other publications, on the company website, or in order-related documents such as shipping notes, order confirmations and product labels. **The varying representations of the ordering codes are due to different processes employed and do not affect the specifications of the respective products.** Detailed information can be found on the Internet under www.tdk-electronics.tdk.com/orderingcodes.

Important notes

The following applies to all products named in this publication:

1. Some parts of this publication contain **statements about the suitability of our products for certain areas of application**. These statements are based on our knowledge of typical requirements that are often placed on our products in the areas of application concerned. We nevertheless expressly point out **that such statements cannot be regarded as binding statements about the suitability of our products for a particular customer application**. As a rule, we are either unfamiliar with individual customer applications or less familiar with them than the customers themselves. For these reasons, it is always ultimately incumbent on the customer to check and decide whether a product with the properties described in the product specification is suitable for use in a particular customer application.
2. We also point out that **in individual cases, a malfunction of electronic components or failure before the end of their usual service life cannot be completely ruled out in the current state of the art, even if they are operated as specified**. In customer applications requiring a very high level of operational safety and especially in customer applications in which the malfunction or failure of an electronic component could endanger human life or health (e.g. in accident prevention or life-saving systems), it must therefore be ensured by means of suitable design of the customer application or other action taken by the customer (e.g. installation of protective circuitry or redundancy) that no injury or damage is sustained by third parties in the event of malfunction or failure of an electronic component.
3. **The warnings, cautions and product-specific notes must be observed.**
4. In order to satisfy certain technical requirements, **some of the products described in this publication may contain substances subject to restrictions in certain jurisdictions (e.g. because they are classed as hazardous)**. Useful information on this will be found in our Material Data Sheets on the Internet (www.tdk-electronics.tdk.com/material). Should you have any more detailed questions, please contact our sales offices.
5. We constantly strive to improve our products. Consequently, **the products described in this publication may change from time to time**. The same is true of the corresponding product specifications. Please check therefore to what extent product descriptions and specifications contained in this publication are still applicable before or when you place an order.
We also **reserve the right to discontinue production and delivery of products**. Consequently, we cannot guarantee that all products named in this publication will always be available. The aforementioned does not apply in the case of individual agreements deviating from the foregoing for customer-specific products.
6. Unless otherwise agreed in individual contracts, **all orders are subject to our General Terms and Conditions of Supply**.

Important notes

7. **Our manufacturing sites serving the automotive business apply the IATF 16949 standard.**
The IATF certifications confirm our compliance with requirements regarding the quality management system in the automotive industry. Referring to customer requirements and customer specific requirements (“CSR”) TDK always has and will continue to have the policy of respecting individual agreements. Even if IATF 16949 may appear to support the acceptance of unilateral requirements, we hereby like to emphasize that **only requirements mutually agreed upon can and will be implemented in our Quality Management System.** For clarification purposes we like to point out that obligations from IATF 16949 shall only become legally binding if individually agreed upon.
8. The trade names EPCOS, CeraCharge, CeraDiode, CeraLink, CeraPad, CeraPlas, CSMP, CTVS, DeltaCap, DigiSiMic, ExoCore, FilterCap, FormFit, LeaXield, MiniBlue, MiniCell, MKD, MKK, MotorCap, PCC, PhaseCap, PhaseCube, PhaseMod, PhiCap, PowerHap, PQSine, PQvar, SIFERRIT, SIFI, SIKOREL, SilverCap, SIMDAD, SiMic, SIMID, SineFormer, SIOV, ThermoFuse, WindCap are **trademarks registered or pending** in Europe and in other countries. Further information will be found on the Internet at www.tdk-electronics.tdk.com/trademarks.

Release 2018-10