

## AVR® DA Family

### Introduction

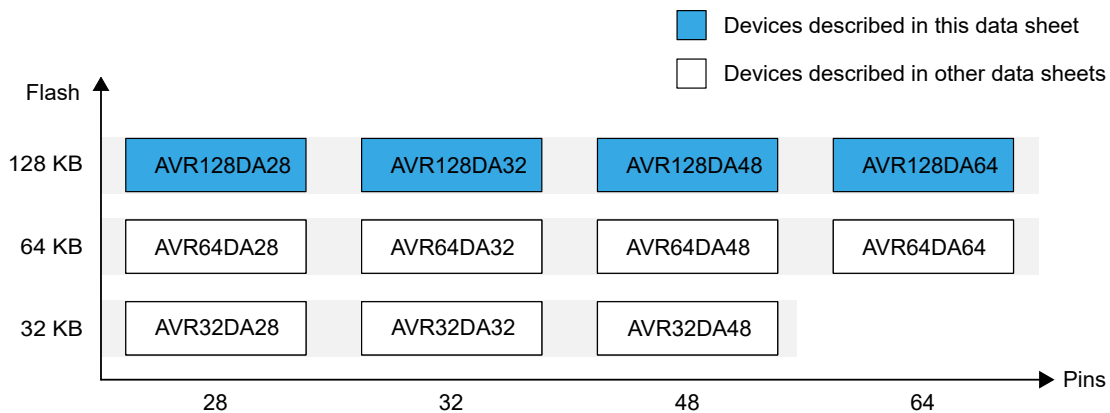
The AVR128DA28/32/48/64 microcontrollers of the AVR® DA family are using the AVR CPU with hardware multiplier, running at up to 24 MHz, with 128 KB of Flash, 16 KB of SRAM, and 512B of EEPROM in 28-, 32-, 48- or 64-pin packages. The AVR® DA family uses the latest technologies from Microchip Technology, with a flexible and low-power architecture including Event System, intelligent analog features, advanced digital peripherals and Peripheral Touch Controller (PTC).

### AVR® DA Family Overview

The figure below shows the AVR® DA devices, laying out pin count variants and memory sizes:

- Vertical migration is possible without code modification, as these devices are fully pin and feature compatible
- Horizontal migration to the left reduces the pin count, and therefore, the available features

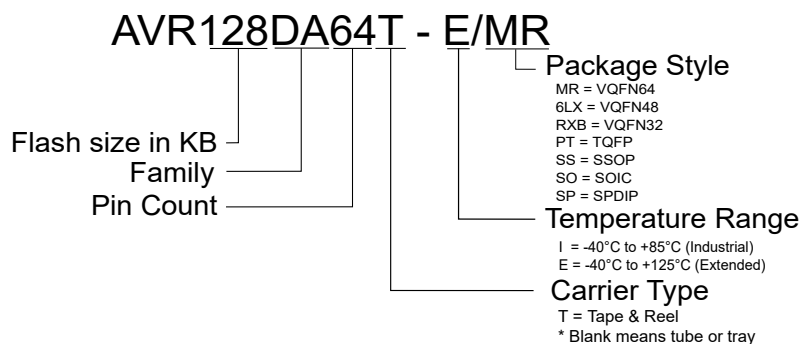
**Figure 1. AVR® DA Family Overview**



Devices with different Flash memory sizes typically also have different SRAM.

The name of a device in the AVR® DA family is decoded as follows:

**Figure 2. AVR® DA Device Designations**



## Memory Overview

The following table shows the memory overview of the entire family. Further documentation describes only the AVR128DA28/32/48/64 devices.

**Table 1. Memory Overview**

Devices	AVR32DA28 AVR32DA32 AVR32DA48	AVR64DA28 AVR64DA32 AVR64DA48 AVR64DA64	AVR128DA28 AVR128DA32 AVR128DA48 AVR128DA64
Flash Memory	32 KB	64 KB	128 KB
SRAM	4 KB	8 KB	16 KB
EEPROM	512B	512B	512B
User Row	32B	32B	32B

## Peripheral Overview

The following table shows the peripheral overview of the entire AVR® DA family. Further documentation describes only the AVR128DA28/32/48/64 devices.

**Table 2. Peripheral Overview**

Feature	AVR128DA28 AVR64DA28 AVR32DA28	AVR128DA32 AVR64DA32 AVR32DA32	AVR128DA48 AVR64DA48 AVR32DA48	AVR128DA64 AVR64DA64
<b>Pins</b>	<b>28</b>	<b>32</b>	<b>48</b>	<b>64</b>
Max. Frequency (MHz)	24	24	24	24
16-bit Timer/Counter type A (TCA)	1	1	2	2
16-bit Timer/Counter type B (TCB)	3	3	4	5
12-bit Timer/Counter type D (TCD)	1	1	1	1
Real-Time Counter (RTC)	1	1	1	1
USART	3	3	5	6
SPI	2	2	2	2
TWI/I <sup>2</sup> C	1 <sup>(1)</sup>	2 <sup>(1)</sup>	2 <sup>(1)</sup>	2 <sup>(1)</sup>
12-bit Differential ADC (channels)	1 (10)	1 (14)	1 (18)	1 (22)
10-bit DAC (outputs)	1(1)	1(1)	1(1)	1(1)
Analog Comparator (AC)	3	3	3	3
Zero-Cross Detectors (ZCD)	1	1	2	3
Peripheral Touch Controller (PTC) (self-cap/mutual cap channels)	1 (18/81)	1 (22/121)	1 (32/256)	1 (46/529)
Custom Logic (LUTs)	1(4)	1(4)	1(6)	1(6)
Watchdog Timer (WDT)	1	1	1	1
Event System channels	8	8	10	10

.....continued				
Feature	AVR128DA28 AVR64DA28 AVR32DA28	AVR128DA32 AVR64DA32 AVR32DA32	AVR128DA48 AVR64DA48 AVR32DA48	AVR128DA64 AVR64DA64
Pins	28	32	48	64
General Purpose I/O <sup>(2)</sup>	23 <sup>(2)</sup>	27 <sup>(2)</sup>	41 <sup>(2)</sup>	55 <sup>(2)</sup>
PORT	PA[7:0], PC[3:0], PD[7:0], PF[6,1,0]	PA[7:0], PC[3:0], PD[7:0],PF[6:0]	PA[7:0], PB[5:0], PC[7:0], PD[7:0], PE[3:0], PF[6:0]	PA[7:0], PB[7:0], PC[7:0], PD[7:0], PE[7:0], PF[6:0], PG[7:0]
External Interrupts	23	27	41	55
CRCSCAN	1	1	1	1
Unified Program and Debug Interface (UPDI)	1	1	1	1

**Notes:**

1. The TWI/I<sup>2</sup>C can operate simultaneously as master and slave on different pins.
2. PF6/RESET pin is input-only.

---

## Features

---

- AVR® CPU
  - Running at up to 24 MHz
  - Single-cycle I/O access
  - Two-level interrupt controller
  - Two-cycle hardware multiplier
  - Supply voltage range: 1.8V to 5.5V
- Memories
  - 128 KB In-System self-programmable Flash memory
  - 512B EEPROM
  - 16 KB SRAM
  - 32B of user row in nonvolatile memory that can keep data during chip-erase and be programmed while the device is locked
  - Write/erase endurance
    - Flash 10,000 cycles
    - EEPROM 100,000 cycles
  - Data retention: 40 years at 55°C
- System
  - Power-on Reset (POR) circuit
  - Brown-out Detector (BOD)
  - Clock options
    - High-Precision internal high-frequency Oscillator with selectable frequency up to 24 MHz (OSCHF)
      - Auto-tuning for improved internal oscillator accuracy
    - Internal PLL up to 48 MHz for high-frequency operation of Timer/Counter type D (PLL)
    - 32.768 kHz Ultra Low-Power internal oscillator (OSC32K)
    - 32.768 kHz external crystal oscillator (XOSC32K)
    - External clock input
  - Single-pin Unified Program and Debug Interface (UPDI)
  - Three sleep modes
    - Idle with all peripherals running for immediate wake-up
    - Standby with a configurable operation of selected peripherals
    - Power-Down with full data retention
- Peripherals
  - Up to two 16-bit Timer/Counter type A (TCA) with a dedicated period register and three PWM channels
  - Up to five 16-bit Timer/Counter type B (TCB) with input capture and simple PWM functionality
  - One 12-bit Timer/Counter type D (TCD) optimized for power control
  - One 16-bit Real-Time Counter (RTC) running from external crystal or internal oscillator
  - Up to six USART with fractional baud rate generator, auto-baud, and start-of-frame detection
  - Two master/slave Serial Peripheral Interface (SPI)
  - Up to two Two-Wire Interface (TWI) with dual address match
    - Independent master and slave operation (Dual mode)
    - Philips I<sup>2</sup>C compatible
    - Standard mode (Sm, 100 kHz)
    - Fast mode (Fm, 400 kHz)
    - Fast mode plus (Fm+, 1 MHz) <sup>(1)</sup>
  - Event System for CPU independent and predictable inter-peripheral signaling
  - Configurable Custom Logic (CCL) with up to six programmable Look-up Tables (LUT)
  - One 12-bit differential 130 ksps Analog-to-Digital Converter (ADC)
  - Three Analog Comparators (ACs) with window compare functions

- One 10-bit Digital-to-Analog Converter (DAC)
- Up to three Zero-Cross Detectors (ZCD)
- Multiple voltage references (VREF)
  - 1.024V
  - 2.048V
  - 2.500V
  - 4.096V
- Peripheral Touch Controller (PTC) with Driven Shield+ and Boost Mode technologies for capacitive touch buttons, sliders, wheels and 2D surface
  - Up to 46 self-capacitance and 529 mutual capacitance channels
- Automated Cyclic Redundancy Check (CRC) Flash memory scan
- Watchdog Timer (WDT) with Window mode, with a separate on-chip oscillator
- External interrupt on all general purpose pins
- I/O and Packages:
  - Up to 55 programmable I/O pins
  - 28-pin SPDIP, SSOP and SOIC
  - 32-pin VQFN 5x5 mm and TQFP 7x7 mm
  - 48-pin VQFN 6x6 mm and TQFP 7x7 mm
  - 64-pin VQFN 9x9 mm and TQFP 10x10 mm
- Temperature Ranges:
  - Industrial: -40°C to +85°C
  - Extended: -40°C to +125°C

**Note:**

1. I<sup>2</sup>C Fm+ is only supported for V<sub>DD</sub> above 2.7V.

## Table of Contents

Introduction.....	1
AVR® DA Family Overview.....	1
1. Memory Overview.....	2
2. Peripheral Overview.....	2
Features.....	4
1. Block Diagram.....	13
2. Pinout.....	14
2.1. 28-Pin SPDIP, SSOP and SOIC.....	14
2.2. 32-Pin VQFN and TQFP.....	15
2.3. 48-Pin VQFN and TQFP.....	16
2.4. 64-Pin VQFN and TQFP.....	17
3. I/O Multiplexing and Considerations.....	18
3.1. I/O Multiplexing.....	18
4. Hardware Guidelines.....	20
4.1. General Guidelines.....	20
4.2. Connection for Power Supply.....	20
4.3. Connection for RESET.....	21
4.4. Connection for UPDI Programming.....	22
4.5. Connecting External Crystal Oscillators.....	22
4.6. Connection for External Voltage Reference.....	23
5. Conventions.....	24
5.1. Numerical Notation.....	24
5.2. Memory Size and Type.....	24
5.3. Frequency and Time.....	24
5.4. Registers and Bits.....	25
5.5. ADC Parameter Definitions.....	26
6. AVR® CPU.....	29
6.1. Features.....	29
6.2. Overview.....	29
6.3. Architecture.....	29
6.4. Functional Description.....	31
6.5. Register Summary.....	35
6.6. Register Description.....	35
7. Memories.....	40
7.1. Overview.....	40
7.2. Memory Map.....	40
7.3. In-System Reprogrammable Flash Program Memory.....	40
7.4. SRAM Data Memory.....	41
7.5. EEPROM Data Memory.....	41

7.6.	SIGROW - Signature Row.....	41
7.7.	USERROW - User Row.....	46
7.8.	FUSE - Configuration and User Fuses.....	46
7.9.	LOCK - Memory Sections Access Protection.....	54
7.10.	I/O Memory.....	57
8.	Peripherals and Architecture.....	60
8.1.	Peripheral Address Map.....	60
8.2.	Interrupt Vector Mapping.....	62
8.3.	SYSCFG - System Configuration.....	64
9.	GPR - General Purpose Registers.....	67
9.1.	Register Summary.....	68
9.2.	Register Description.....	68
10.	NVMCTRL - Nonvolatile Memory Controller.....	70
10.1.	Features.....	70
10.2.	Overview.....	70
10.3.	Functional Description.....	71
10.4.	Register Summary.....	79
10.5.	Register Description.....	79
11.	CLKCTRL - Clock Controller.....	87
11.1.	Features.....	87
11.2.	Overview.....	87
11.3.	Functional Description.....	89
11.4.	Register Summary.....	92
11.5.	Register Description.....	92
12.	SLPCTRL - Sleep Controller.....	102
12.1.	Features.....	102
12.2.	Overview.....	102
12.3.	Functional Description.....	102
12.4.	Register Summary.....	106
12.5.	Register Description.....	106
13.	RSTCTRL - Reset Controller.....	109
13.1.	Features.....	109
13.2.	Overview.....	109
13.3.	Functional Description.....	110
13.4.	Register Summary.....	113
13.5.	Register Description.....	113
14.	CPUINT - CPU Interrupt Controller.....	116
14.1.	Features.....	116
14.2.	Overview.....	116
14.3.	Functional Description.....	117
14.4.	Register Summary.....	122
14.5.	Register Description.....	122

15. EVSYS - Event System.....	127
15.1. Features.....	127
15.2. Overview.....	127
15.3. Functional Description.....	128
15.4. Register Summary.....	134
15.5. Register Description.....	134
16. PORTMUX - Port Multiplexer.....	140
16.1. Overview.....	140
16.2. Register Summary.....	141
16.3. Register Description.....	141
17. PORT - I/O Pin Configuration.....	155
17.1. Features.....	155
17.2. Overview.....	155
17.3. Functional Description.....	157
17.4. Register Summary - PORTx.....	161
17.5. Register Description - PORTx.....	161
17.6. Register Summary - VPORTx.....	178
17.7. Register Description - VPORTx.....	178
18. BOD - Brown-out Detector.....	183
18.1. Features.....	183
18.2. Overview.....	183
18.3. Functional Description.....	184
18.4. Register Summary.....	186
18.5. Register Description.....	186
19. VREF - Voltage Reference.....	193
19.1. Features.....	193
19.2. Overview.....	193
19.3. Functional Description.....	193
19.4. Register Summary.....	194
19.5. Register Description.....	194
20. WDT - Watchdog Timer .....	198
20.1. Features.....	198
20.2. Overview.....	198
20.3. Functional Description.....	198
20.4. Register Summary.....	202
20.5. Register Description.....	202
21. TCA - 16-bit Timer/Counter Type A.....	206
21.1. Features.....	206
21.2. Overview.....	206
21.3. Functional Description.....	208
21.4. Register Summary - Normal Mode.....	218
21.5. Register Description - Normal Mode.....	218
21.6. Register Summary - Split Mode.....	237



21.7. Register Description - Split Mode.....	237
22. TCB - 16-bit Timer/Counter Type B.....	253
22.1. Features.....	253
22.2. Overview.....	253
22.3. Functional Description.....	255
22.4. Register Summary.....	265
22.5. Register Description.....	265
23. TCD - 12-Bit Timer/Counter Type D.....	276
23.1. Features.....	276
23.2. Overview.....	276
23.3. Functional Description.....	278
23.4. Register Summary.....	301
23.5. Register Description.....	301
24. RTC - Real-Time Counter.....	326
24.1. Features.....	326
24.2. Overview.....	326
24.3. Clocks.....	327
24.4. RTC Functional Description.....	327
24.5. PIT Functional Description.....	328
24.6. Crystal Error Correction.....	329
24.7. Events.....	329
24.8. Interrupts.....	330
24.9. Sleep Mode Operation.....	331
24.10. Synchronization.....	331
24.11. Debug Operation.....	331
24.12. Register Summary.....	332
24.13. Register Description.....	332
25. USART - Universal Synchronous and Asynchronous Receiver and Transmitter.....	349
25.1. Features.....	349
25.2. Overview.....	349
25.3. Functional Description.....	350
25.4. Register Summary.....	365
25.5. Register Description.....	365
26. SPI - Serial Peripheral Interface.....	383
26.1. Features.....	383
26.2. Overview.....	383
26.3. Functional Description.....	384
26.4. Register Summary.....	391
26.5. Register Description.....	391
27. TWI - Two-Wire Interface.....	398
27.1. Features.....	398
27.2. Overview.....	398
27.3. Functional Description.....	399

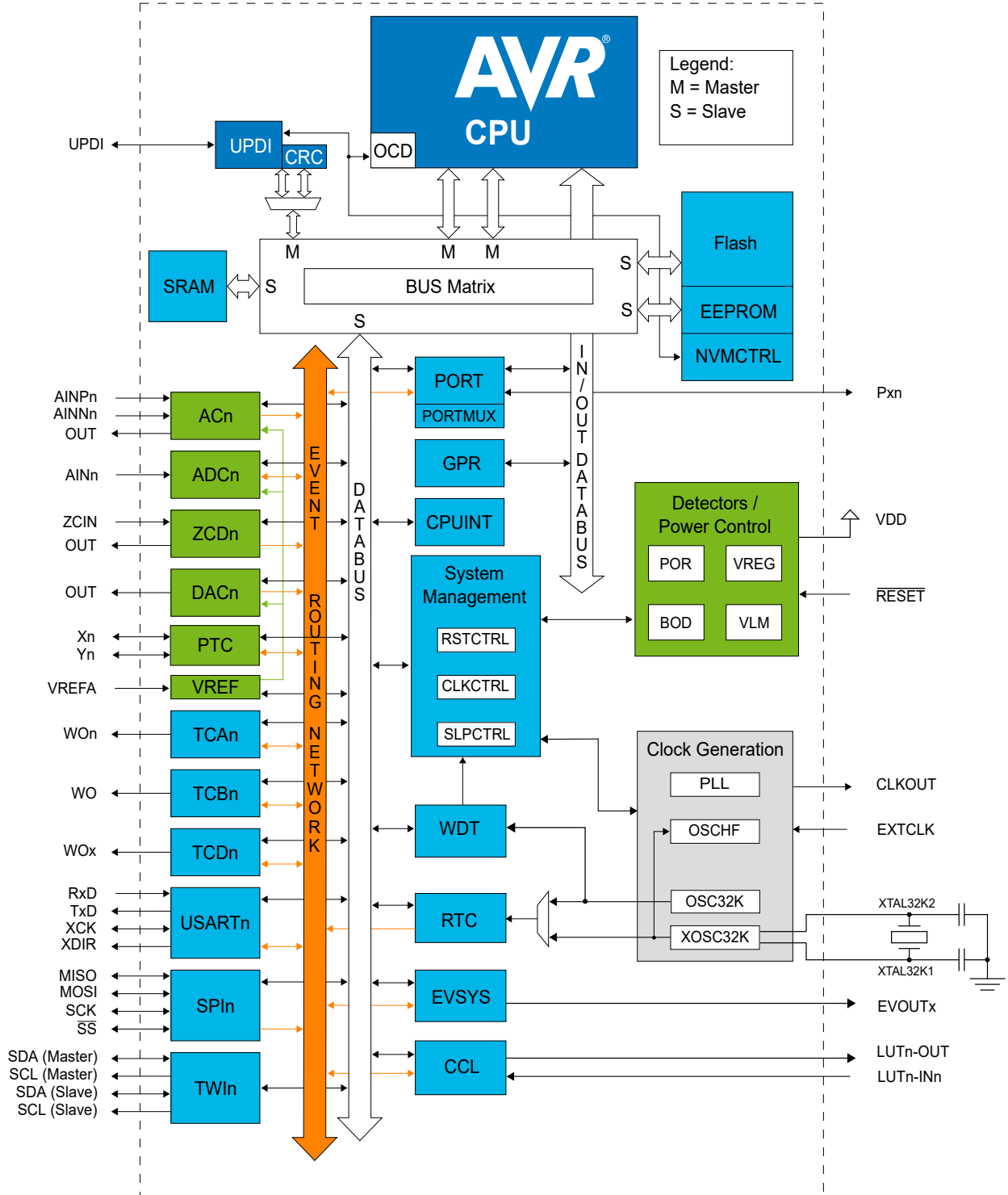
27.4. Register Summary.....	410
27.5. Register Description.....	410
28. CRCSCAN - Cyclic Redundancy Check Memory Scan.....	428
28.1. Features.....	428
28.2. Overview.....	428
28.3. Functional Description.....	428
28.4. Register Summary.....	431
28.5. Register Description.....	431
29. CCL – Configurable Custom Logic.....	435
29.1. Features.....	435
29.2. Overview.....	435
29.3. Functional Description.....	437
29.4. Register Summary.....	445
29.5. Register Description.....	445
30. AC - Analog Comparator.....	458
30.1. Features.....	458
30.2. Overview.....	458
30.3. Functional Description.....	459
30.4. Register Summary .....	463
30.5. Register Description.....	463
31. ADC - Analog-to-Digital Converter.....	470
31.1. Features.....	470
31.2. Overview.....	470
31.3. Functional Description.....	471
31.4. Register Summary.....	482
31.5. Register Description.....	482
32. DAC - Digital-to-Analog Converter.....	500
32.1. Features.....	500
32.2. Overview.....	500
32.3. Functional Description.....	500
32.4. Register Summary.....	502
32.5. Register Description.....	502
33. PTC - Peripheral Touch Controller.....	505
33.1. Features.....	505
33.2. Overview.....	505
33.3. Block Diagram.....	506
33.4. Signal Description.....	507
33.5. System Dependencies.....	507
33.6. Functional Description.....	508
34. ZCD - Zero-Cross Detector.....	509
34.1. Features.....	509
34.2. Overview.....	509

34.3. Functional Description.....	510
34.4. Register Summary.....	517
34.5. Register Description.....	517
35. UPDI - Unified Program and Debug Interface.....	521
35.1. Features.....	521
35.2. Overview.....	521
35.3. Functional Description.....	523
35.4. Register Summary.....	542
35.5. Register Description.....	542
36. Instruction Set Summary.....	553
37. Electrical Characteristics.....	554
37.1. Disclaimer.....	554
37.2. Absolute Maximum Ratings .....	554
37.3. Standard Operating Conditions .....	554
37.4. DC Characteristics.....	555
37.5. AC Characteristics.....	561
38. Typical Characteristics .....	573
39. Ordering Information.....	574
40. Package Drawings.....	576
40.1. Online Package Drawings.....	576
40.2. 28-Pin SPDIP.....	577
40.3. 28-Pin SOIC.....	578
40.4. 28-Pin SSOP.....	581
40.5. 32-Pin VQFN.....	584
40.6. 32-Pin TQFP.....	587
40.7. 48-Pin VQFN.....	590
40.8. 48-Pin TQFP.....	593
40.9. 64-Pin VQFN.....	596
40.10. 64-Pin TQFP.....	599
41. Data Sheet Revision History.....	602
41.1. ....	602
The Microchip Website.....	603
Product Change Notification Service.....	603
Customer Support.....	603
Product Identification System.....	604
Microchip Devices Code Protection Feature.....	604
Legal Notice.....	604
Trademarks.....	605

Quality Management System..... 605

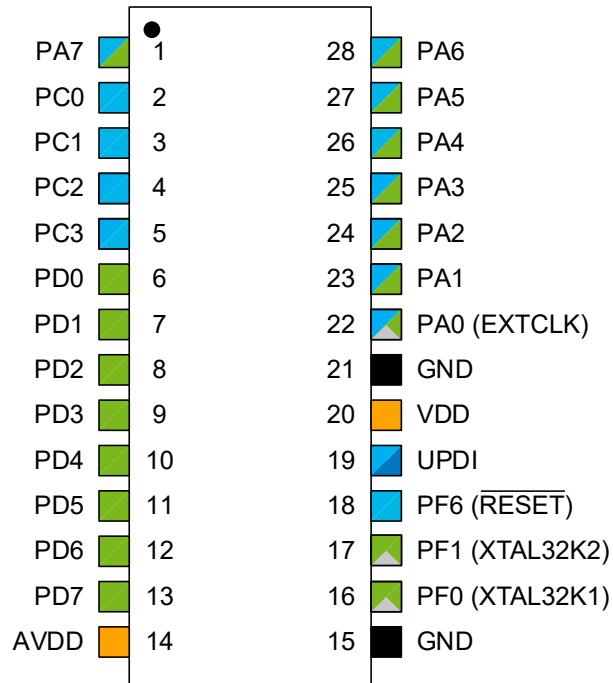
Worldwide Sales and Service.....606

1. Block Diagram







## 2. Pinout





### 2.1 28-Pin SPDIP, SSOP and SOIC



#### Power

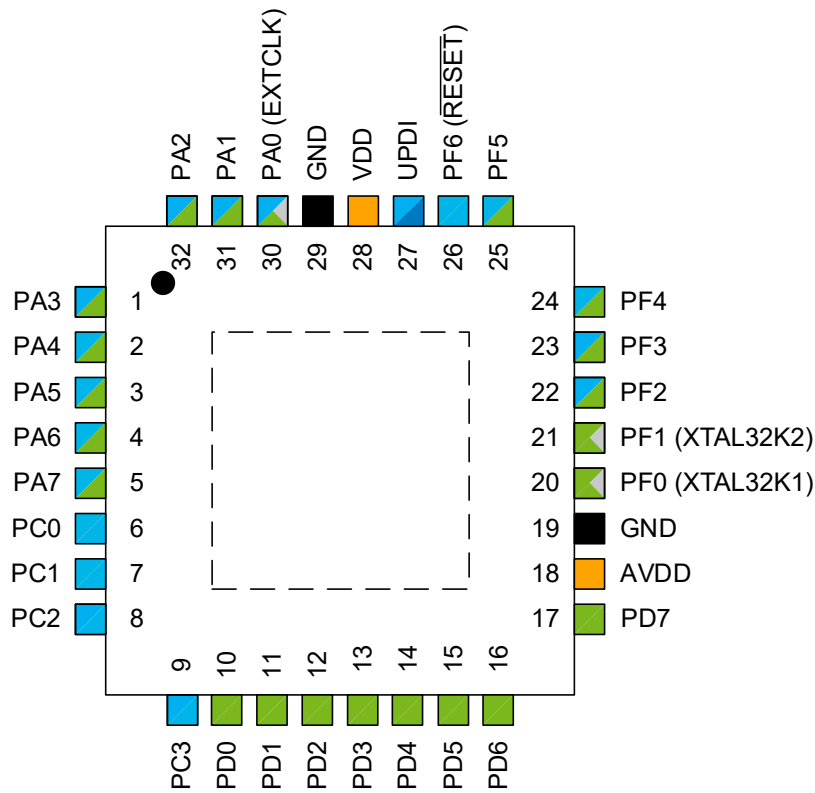
-  Power Supply
-  Ground
-  Pin on VDD Power Domain
-  Pin on AVDD Power Domain

#### Functionality

-  Programming/Debug
-  Clock/Crystal
-  Digital Function Only
-  Analog Function

**Note:** For the AVR® DA Family, the VDD and AVDD are internally connected (no separate power domains).

### 2.2 32-Pin VQFN and TQFP



#### Power

 Power Supply

 Ground

 Pin on VDD Power Domain

 Pin on AVDD Power Domain

#### Functionality

 Programming/Debug

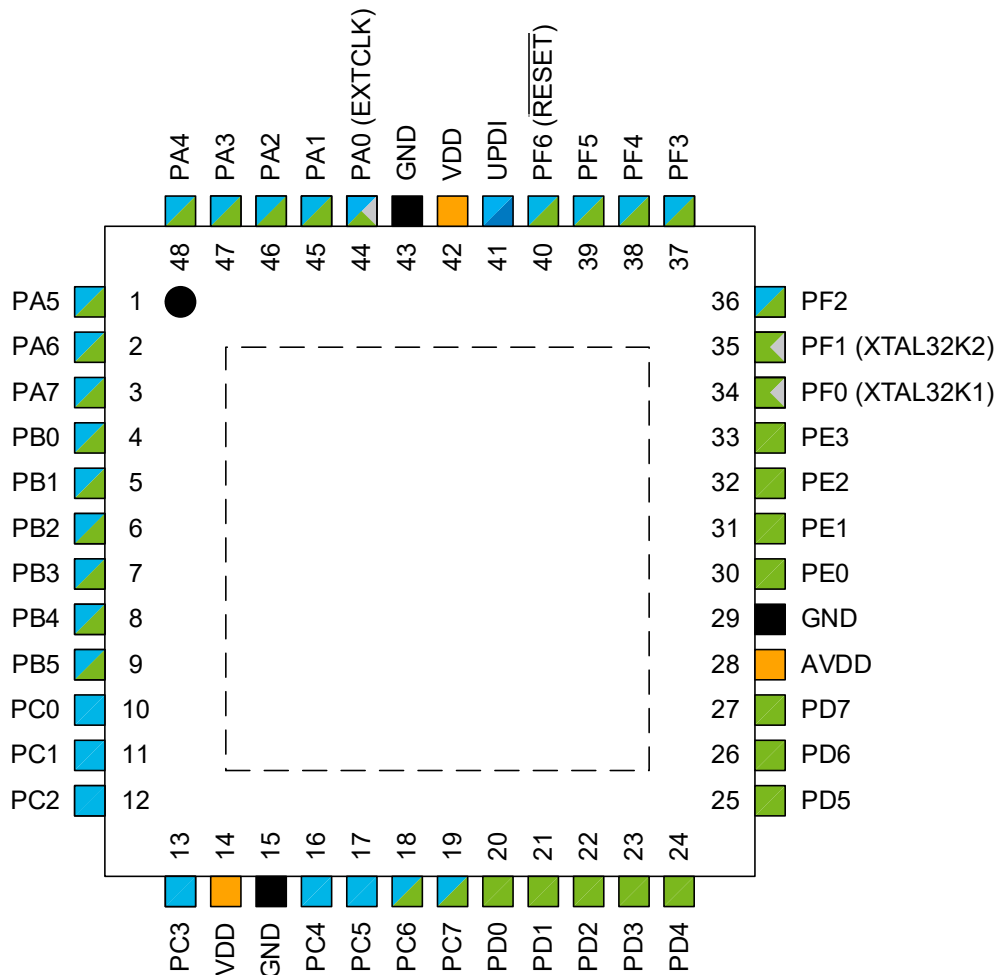
 Clock/Crystal

 Digital Function Only

 Analog Function

**Note:** For the AVR® DA Family, the VDD and AVDD are internally connected (no separate power domains).

2.3 48-Pin VQFN and TQFP



**Power**

Power Supply

Ground

Pin on VDD Power Domain

Pin on AVDD Power Domain

**Functionality**

Programming/Debug

Clock/Crystal

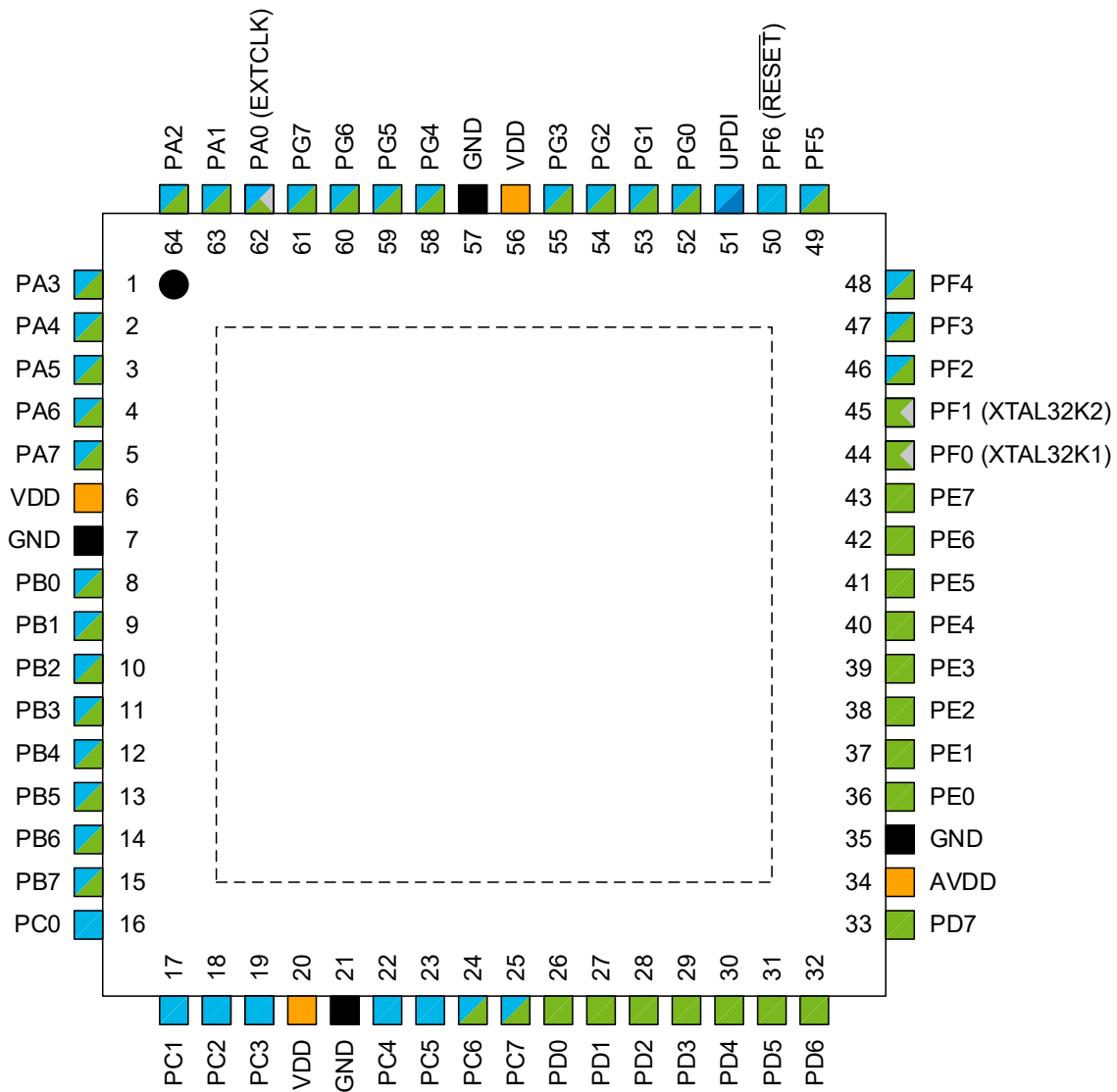
Digital Function Only

Analog Function

**Note:** For the AVR® DA Family, the VDD and AVDD are internally connected (no separate power domains).



2.4 64-Pin VQFN and TQFP



**Power**

- Power Supply
- Ground
- Pin on VDD Power Domain
- Pin on AVDD Power Domain

**Functionality**

- Programming/Debug
- Clock/Crystal
- Digital Function Only
- Analog Function

**Note:** For the AVR® DA Family, the VDD and AVDD are internally connected (no separate power domains).

### 3. I/O Multiplexing and Considerations

#### 3.1 I/O Multiplexing

VQFN64/ TQFP64	VQFN48/ TQFP48	VQFN32/ TQFP32	SPDI28/ SOIC28/ SSOP28	Pin name (1,2)	Special	ADC0	PTC	ACn	DAC0	ZCdn	USARTn	SPIn	TWIn(4)	TCA0	TCA1	TCBn	TCdn	EVSYS	CCL-LUTn
62	44	30	22	PA0	EXTCLK		X0/Y0				0,TxD			WO0					0,IN0
63	45	31	23	PA1			X1/Y1				0,RxD			WO1					0,IN1
64	46	32	24	PA2	TWI		X2/Y2				0,XCK		0,SDA(M)	WO2		0,WO		EVOUTA	0,IN2
1	47	1	25	PA3	TWI		X3/Y3				0,XDIR		0,SCL(M)	WO3		1,WO			0,OUT
2	48	2	26	PA4			X4/Y4				0,TxD(3)	0,MOSI		WO4			0,WOA		
3	1	3	27	PA5			X5/Y5				0,RxD(3)	0,MISO		WO5			0,WOB		
4	2	4	28	PA6			X6/Y6				0,XCK(3)	0,SCK					0,WOC		0,OUT(3)
5	3	5	1	PA7	CLKOUT		X7/Y7	0,OUT 1,OUT 2,OUT		0,OUT 2,OUT	0,XDIR(3)	0,SS					0,WOD	EVOUTA (3)	
6				VDD															
7				GND															
8	4			PB0			X8/Y8				3,TxD			WO0(3)	WO0				4,IN0
9	5			PB1			X9/Y9				3,RxD			WO1(3)	WO1				4,IN1
10	6			PB2			X10/Y10				3,XCK		1,SDA(M)(3)	WO2(3)	WO2			EVOUTB	4,IN2
11	7			PB3			X11/Y11				3,XDIR		1,SCL(M)(3)	WO3(3)	WO3				4,OUT
12	8			PB4			X12/Y12				3,TxD(3)	1,MOSI(3)		WO4(3)	WO4	2,WO(3)	0,WOA(3)		
13	9			PB5			X13/Y13				3,RxD(3)	1,MISO(3)		WO5(3)	WO5	3,WO	0,WOB(3)		
14				PB6			X14/Y14				3,XCK(3)	1,SCK(3)	1,SDA(S)(3)				0,WOC(3)		4,OUT(3)
15				PB7			X15/Y15				3,XDIR(3)	1,SS(3)	1,SCL(S)(3)				0,WOD(3)	EVOUTB (3)	
16	10	6	2	PC0							1,TxD	1,MOSI		WO0(3)		2,WO			1,IN0
17	11	7	3	PC1							1,RxD	1,MISO		WO1(3)		3,WO(3)			1,IN1
18	12	8	4	PC2	TWI						1,XCK	1,SCK	0,SDA(M)(3)	WO2(3)				EVOUTC	1,IN2
19	13	9	5	PC3	TWI						1,XDIR	1,SS	0,SCL(M)(3)	WO3(3)					1,OUT
20	14			VDD															
21	15			GND															
22	16			PC4							1,TxD(3)	1,MOSI(3)		WO4(3)	WO0(3)				
23	17			PC5							1,RxD(3)	1,MISO(3)		WO5(3)	WO1(3)				
24	18			PC6				0,OUT(3) 1,OUT(3) 2,OUT(3)			1,XCK(3)	1,SCK(3)	0,SDA(S)		WO2(3)	4,WO(3)			1,OUT(3)
25	19			PC7				0,OUT(3) 1,OUT(3) 2,OUT(3)		0,OUT(3) 2,OUT(3)	1,XDIR(3)	1,SS(3)	0,SCL(S)					EVOUTC (3)	
26	20	10	6	PD0		AIN0	X16/Y16	0,AINN1 1,AINN1 2,AINN1						WO0(3)					2,IN0
27	21	11	7	PD1		AIN1	X17/Y17			0,ZCIN				WO1(3)					2,IN1
28	22	12	8	PD2		AIN2	X18/Y18	0,AINP0 1,AINP0 2,AINP0						WO2(3)				EVOUTD	2,IN2
29	23	13	9	PD3		AIN3	X19/Y19	0,AINN0 1,AINP1						WO3(3)					2,OUT

# AVR128DA28/32/48/64

## I/O Multiplexing and Considerations

.....continued

VQFN64/ TQFP64	VQFN48/ TQFP48	VQFN32/ TQFP32	SPDIP28/ SOIC28/ SSOP28	Pin name (1,2)	Special	ADC0	PTC	ACh	DAC0	ZcDn	USARTn	SPIn	TWIn(4)	TCAn	TCAn	TCBn	TCBn	EVSYS	CCL-LUTn
30	24	14	10	PD4		AIN4	X20/Y20	1,AINP2 2,AINP1						WO4(3)					
31	25	15	11	PD5		AIN5	X21/Y21	1,AINN0						WO5(3)					
32	26	16	12	PD6		AIN6	X22/Y22	0,AINP3 1,AINP3 2,AINP3	VOUT										2,OUT(3)
33	27	17	13	PD7	VREFA	AIN7	X23/Y23	0,AINN2 1,AINN2 2,AINN0/AINN2										EVOUTD (3)	
34	28	18	14	AVDD															
35	29	19	15	GND															
36	30			PE0		AIN8	X24/Y24	0,AINP1			4,TxD	0,MOSI(3)		WO0(3)					
37	31			PE1		AIN9	X25/Y25	2,AINP2			4,RxD	0,MISO(3)		WO1(3)					
38	32			PE2		AIN10	X26/Y26	0,AINP2			4,XCK	0,SCK(3)		WO2(3)				EVOUTE	
39	33			PE3		AIN11	X27/Y27		1,ZCIN	4,XDIR	0,SS(3)			WO3(3)					
40				PE4		AIN12	X28/Y28			4,TxD(3)				WO4(3)	WO0(3)				
41				PE5		AIN13	X29/Y29			4,RxD(3)				WO5(3)	WO1(3)				
42				PE6		AIN14	X30/Y30			4,XCK(3)					WO2(3)				
43				PE7		AIN15	X31/Y31		2,ZCIN	4,XDIR(3)								EVOUTE (3)	
44	34	20	16	PF0	XTAL32K1	AIN16(6)	X32/Y32			2,TxD				WO0(3)			0,WOA(3)		3,IN0
45	35	21	17	PF1	XTAL32K2	AIN17(6)	X33/Y33			2,RxD				WO1(3)			0,WOB(3)		3,IN1
46	36	22		PF2	TWI	AIN18(6)	X34/Y34			2,XCK		1,SDA(M)		WO2(3)			0,WOC(3)	EVOUTF	3,IN2
47	37	23		PF3	TWI	AIN19(6)	X35/Y35			2,XDIR		1,SCL(M)		WO3(3)			0,WOD(3)		3,OUT
48	38	24		PF4		AIN20(6)	X36/Y36			2,TxD(3)				WO4(3)		0,WO(3)			
49	39	25		PF5		AIN21(6)	X37/Y37			2,RxD(3)				WO5(3)		1,WO(3)			
50	40	26	18	PF6 (5)	RESET														
51	41	27	19	UPDI															
52				PG0			X40/Y40			5,TxD				WO0(3)	WO0(3)				5,IN0
53				PG1			X41/Y41			5,RxD				WO1(3)	WO1(3)				5,IN1
54				PG2			X42/Y42			5,XCK				WO2(3)	WO2(3)			EVOUTG	5,IN2
55				PG3			X43/Y43			5,XDIR				WO3(3)	WO3(3)	4,WO			5,OUT
56	42	28	20	VDD															
57	43	29	21	GND															
58				PG4			X44/Y44			5,TxD(3)	0,MOSI(3)			WO4(3)	WO4(3)		0,WOA(3)		
59				PG5			X45/Y45			5,RxD(3)	0,MISO(3)			WO5(3)	WO5(3)		0,WOB(3)		
60				PG6			X46/Y46			5,XCK(3)	0,SCK(3)						0,WOC(3)		5,OUT(3)
61				PG7			X47/Y47			5,XDIR(3)	0,SS(3)						0,WOD(3)	EVOUTG (3)	

**Notes:**

1. Pins names are of type Pxn, with x being the PORT instance (A, B, C, ...) and n the pin number. Notation for signals is PORTx\_PINn. All pins can be used as event input.
2. All pins can be used for external interrupt, where pins Px2 and Px6 of each port have full asynchronous detection.
3. Alternate pin positions. For selecting the alternate positions, refer to the *Port Multiplexer* section.
4. The TWI pins that can be used as master or slave are marked M. Pins with slave only are marked S.
5. Input-only.
6. Positive input-only.

## 4. Hardware Guidelines

This section contains guidelines for designing or reviewing electrical schematics using AVR 8-bit microcontrollers. The information presented here is just a brief overview of the most common topics. For more detailed information, suitable application notes are presented where applicable.

The Hardware Guidelines covers the following topics:

- General guidelines
- Power supply
- RESET
- UPDI (Unified Program and Debug Interface)
- Crystal Oscillators
- External voltage references

### 4.1 General Guidelines

Soldering pads of unused pins should not be connected to the circuit.

The PORT pins are in their default state after Reset. Follow the recommendations in the *PORT - I/O Pin Configuration* section to reduce power consumption.

All values are given as typical values and serve only as a starting point.

Refer to the following application notes for further information:

- *AVR040 - EMC Design Considerations*
- *AVR042 - AVR Hardware Design Considerations*

#### 4.1.1 Special Consideration for VQFN Packages

VQFN packages have a large pad on the bottom side. This pad is not electrically connected to the internal circuit of the chip, but it is mechanically bonded to the internal substrate and serves as a thermal heat sink as well as providing added mechanical stability. This pad must be connected to GND since the ground plane is the best heat sink (largest copper area) of the printed circuit board (PCB).

### 4.2 Connection for Power Supply

The basics and details regarding the design of the power supply itself lie beyond the scope of these guidelines. For more detailed information about this subject, see the application notes mentioned at the beginning of this section.

A decoupling capacitor should be placed close to the microcontroller for each supply pin pair (VDD, AVDD or other power supply pin and its corresponding GND pin). If you place the decoupling capacitor too far away from the microcontroller, you risk creating a high current loop that will result in increased noise and increased radiated emission.

Each supply pin pair (power input pin and ground pin) must have separate decoupling capacitors.

It is recommended to place the decoupling capacitor on the same side of the PCB as the microcontroller. If space does not allow it, the decoupling capacitor may be placed on the other side through a via, but make sure the distance to the supply pin is kept as short as possible.

If the board is experiencing high-frequency noise (upward of tens of MHz), add a second ceramic type capacitor in parallel to the decoupling capacitor described above. Place this second capacitor next to the primary decoupling capacitor.

On the board layout from the power supply circuit, run the power and return traces to the decoupling capacitors first, and then to the device pins. This ensures that the decoupling capacitors are first in the power chain. Equally important is to keep the trace length between the capacitor and the power pins to a minimum, thereby reducing PCB trace inductance.

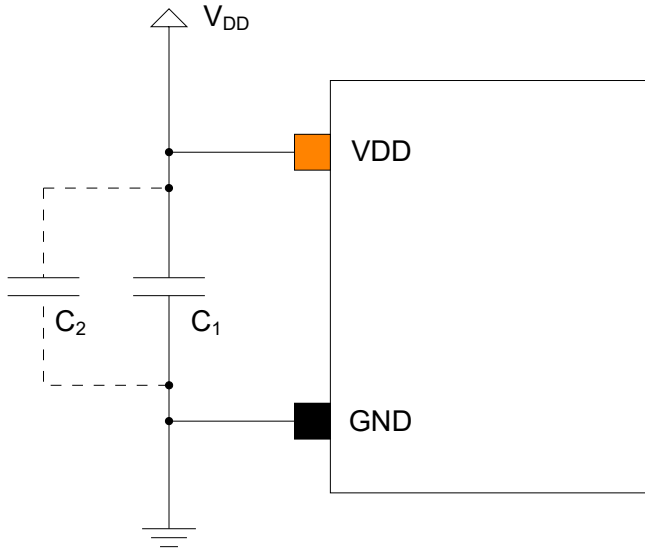
As mentioned at the beginning of this section, all values used in examples are typical values. The actual design may require other values.

### 4.2.1 Digital Power Supply

For larger pin count package types, there is more than one VDD pin and corresponding GND pin. All the VDD pins in the microcontroller are internally connected. The same voltage must be applied to each of the VDD pins.

The following figure shows the recommendation for connecting a power supply to the VDD pin(s) of the device.

**Figure 4-1. Recommended V<sub>DD</sub> Connection Circuit Schematic**



**Typical values (recommended):**

C<sub>1</sub>: 1 μF (primary decoupling capacitor)

C<sub>2</sub>: 1-10 nF (HF decoupling capacitor)

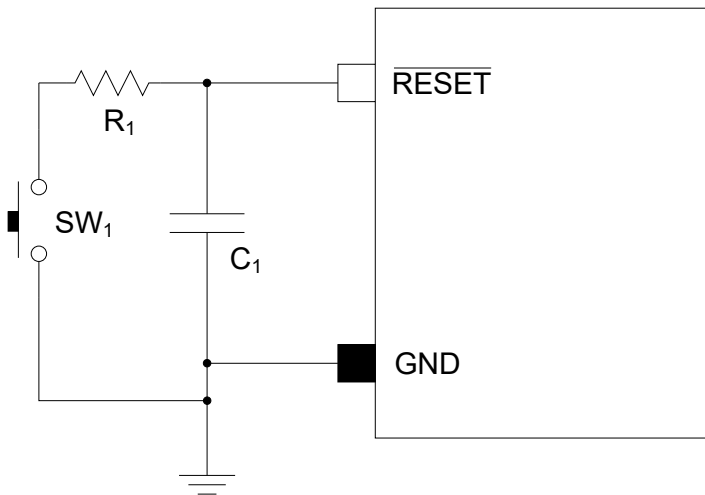
### 4.3 Connection for $\overline{\text{RESET}}$

The  $\overline{\text{RESET}}$  pin on the device is active-low, and setting the pin low externally will result in a Reset of the device.

AVR devices feature an internal pull-up resistor on the  $\overline{\text{RESET}}$  pin, and an external pull-up resistor is normally not required.

The following figure shows the recommendation for connecting an external Reset switch to the device.

**Figure 4-2. Recommended External Reset Circuit Schematic**



**Typical values (recommended):**

C<sub>1</sub>: 100 nF (filtering capacitor)

R<sub>1</sub>: 330Ω (switch series resistance)

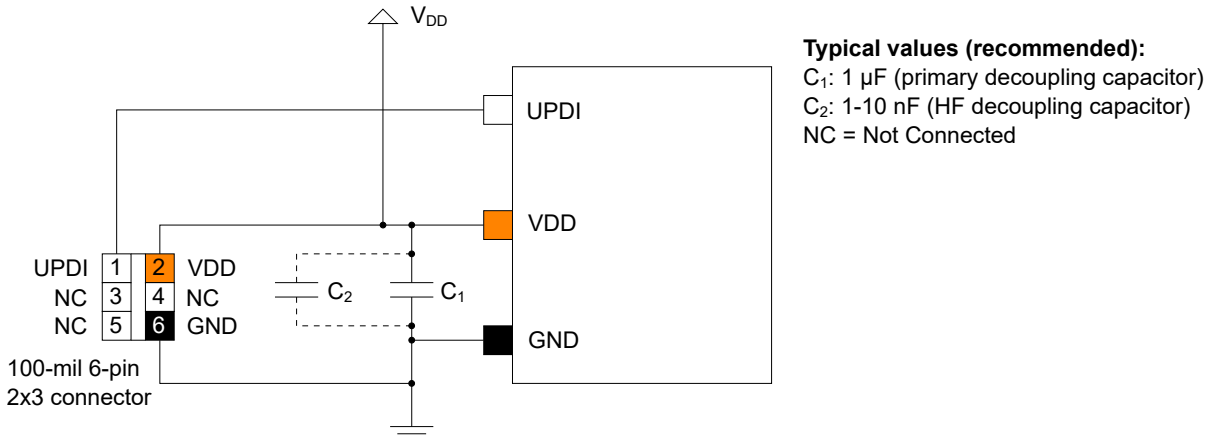
A resistor in series with the switch can safely discharge the filtering capacitor. This prevents a current surge when shorting the filtering capacitor, which again can cause a noise spike that can harm the system.

#### 4.4 Connection for UPDI Programming

The standard connection for UPDI programming is a 100-mil 6-pin 2x3 header. Even though three pins are sufficient for programming most AVR devices, it is recommended to use a 2x3 header since most programming tools are delivered with 100-mil 6-pin 2x3 connectors.

The following figure shows the recommendation for connecting a UPDI connector to the device.

**Figure 4-3. Recommended UPDI Programming Circuit Schematic**

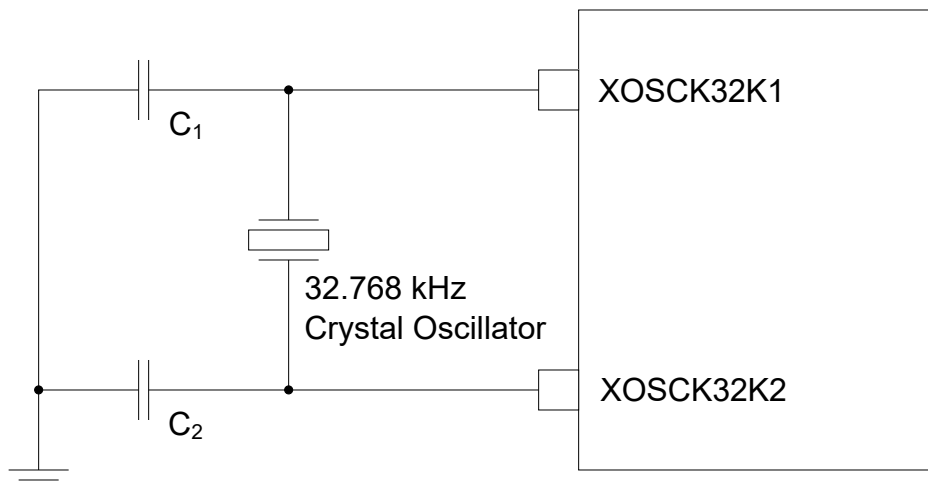


The decoupling capacitor between V<sub>DD</sub> and GND should be placed as close to the pin pair as possible and should be included even if the UPDI connector is not included in the circuit.

#### 4.5 Connecting External Crystal Oscillators

The use of external oscillators and the design of oscillator circuits is not trivial. This is because there are many variables: V<sub>DD</sub>, operating temperature range, crystal type and manufacture, loading capacitors, circuit layout and PCB material. Presented here are some typical guidelines to help with the basic oscillator circuit design.

**Figure 4-4. Recommended External 32.768 kHz Oscillator Connection Circuit Schematic**



- Even the best performing oscillator circuits and high-quality crystals will not perform well if the layout and materials used during assembly are not carefully considered. Ultra low-power 32.768 kHz oscillators typically dissipate significantly below 1 μW, and the current flowing in the circuit is, therefore, extremely small. Also, the crystal frequency is highly dependent on the capacitive load.
- The crystal circuit should be placed on the same side of the board as the device. Place the crystal circuit as close to the respective oscillator pins as possible and avoid long traces. This will reduce parasitic capacitance

and increase immunity against noise and crosstalk. The load capacitors should be placed next to the crystal itself, on the same side of the board. Any kind of sockets should be avoided.

- Place a grounded copper area around the crystal circuit to isolate it from surrounding circuits. If the circuit board has two sides, the copper area on the bottom layer should be a solid area covering the crystal circuit. The copper area on the top layer should surround the crystal circuit and tie to the bottom layer area using via(s).
- Do not run any signal traces or power traces inside the grounded copper area. Avoid routing digital lines, especially clock lines, close to the crystal lines.
- If using a two-sided PCB, avoid any traces beneath the crystal. For a multilayer PCB, avoid routing signals below the crystal lines.
- Dust and humidity will increase parasitic capacitance and reduce signal isolation. A protective coating is recommended.
- Successful oscillator design requires good specifications of operating conditions, a component selection phase with initial testing, and testing in actual operating conditions to ensure that the oscillator performs as desired.

For more detailed information about oscillators and oscillator circuit design, read the following application notes:

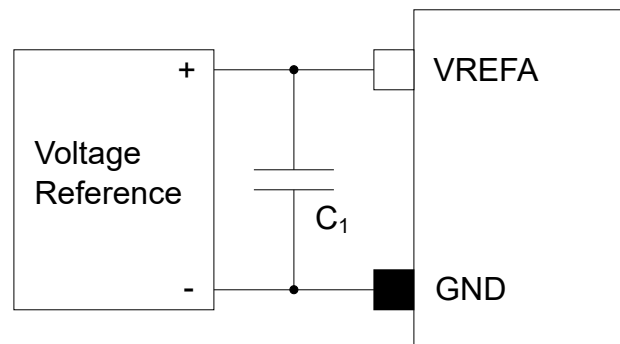
- *AN2648 - Selecting and Testing 32 KHz Crystal Oscillators for AVR® Microcontrollers*
- *AN949 - Making Your Oscillator Work*

## 4.6 Connection for External Voltage Reference

If the design includes the use of external voltage references for analog modules, like the Analog-to-Digital Converter (ADC), the general recommendation is to use a suitable capacitor connected in parallel with the reference. The value of the capacitor depends on the nature of the reference and the type of electrical noise that needs to be filtered out.

Some references will also need additional filtering components. It is beyond the scope of these Hardware Guidelines to describe possible reference sources and their suggested filtering components, but in many cases, this will be described in the External Voltage Reference data sheet.

**Figure 4-5. Recommended External Voltage Reference Connection**



## 5. Conventions

### 5.1 Numerical Notation

**Table 5-1. Numerical Notation**

Symbol	Description
165	Decimal number
0b0101	Binary number
'0101'	Binary numbers are given without prefix if unambiguous
0x3B24	Hexadecimal number
X	Represents an unknown or do not care value
Z	Represents a high-impedance (floating) state for either a signal or a bus

### 5.2 Memory Size and Type

**Table 5-2. Memory Size and Bit Rate**

Symbol	Description
KB	kilobyte ( $2^{10}\text{B} = 1024\text{B}$ )
MB	megabyte ( $2^{20}\text{B} = 1024 \text{KB}$ )
GB	gigabyte ( $2^{30}\text{B} = 1024 \text{MB}$ )
b	bit (binary '0' or '1')
B	byte (8 bits)
1 kbit/s	1,000 bit/s rate
1 Mbit/s	1,000,000 bit/s rate
1 Gbit/s	1,000,000,000 bit/s rate
word	16-bit

### 5.3 Frequency and Time

**Table 5-3. Frequency and Time**

Symbol	Description
kHz	1 kHz = $10^3 \text{ Hz} = 1,000 \text{ Hz}$
MHz	1 MHz = $10^6 \text{ Hz} = 1,000,000 \text{ Hz}$
GHz	1 GHz = $10^9 \text{ Hz} = 1,000,000,000 \text{ Hz}$
ms	1 ms = $10^{-3}\text{s} = 0.001\text{s}$
$\mu\text{s}$	1 $\mu\text{s} = 10^{-6}\text{s} = 0.000001\text{s}$
ns	1 ns = $10^{-9}\text{s} = 0.000000001\text{s}$



## 5.4 Registers and Bits

Table 5-4. Register and Bit Mnemonics

Symbol	Description
R/W	Read/Write accessible register bit. The user can read from and write to this bit.
R	Read-only accessible register bit. The user can only read this bit. Writes will be ignored.
W	Write-only accessible register bit. The user can only write this bit. Reading this bit will return an undefined value.
BITFIELD	Bitfield names are shown in uppercase. Example: INTMODE.
BITFIELD[n:m]	A set of bits from bit n down to m. Example: PINA[3:0] = {PINA3, PINA2, PINA1, PINA0}.
Reserved	Reserved bits, bit fields, and bit field values are unused and reserved for future use. For compatibility with future devices, always write reserved bits to '0' when the register is written. Reserved bits will always return zero when read.
PERIPHERALn	If several instances of the peripheral exist, the peripheral name is followed by a single number to identify one instance. Example: USARTn is the collection of all instances of the USART module, while USART3 is one specific instance of the USART module.
PERIPHERALx	If several instances of the peripheral exist, the peripheral name is followed by a single capital letter (A-Z) to identify one instance. Example: PORTx is the collection of all instances of the PORT module, while PORTB is one specific instance of the PORT module.
Reset	Value of a register after a Power-on Reset. This is also the value of registers in a peripheral after performing a software Reset of the peripheral, except for the Debug Control registers.
SET/CLR/TGL	Registers with SET/CLR/TGL suffix allow the user to clear and set bits in a register without doing a read-modify-write operation. Each SET/CLR/TGL register is paired with the register it is affecting. Both registers in a register pair return the same value when read.  Example: In the PORT peripheral, the OUT and OUTSET registers form such a register pair. The contents of OUT will be modified by a write to OUTSET. Reading OUT and OUTSET will return the same value.  Writing a '1' to a bit in the CLR register will clear the corresponding bit in both registers.  Writing a '1' to a bit in the SET register will set the corresponding bit in both registers.  Writing a '1' to a bit in the TGL register will toggle the corresponding bit in both registers.

### 5.4.1 Addressing Registers from Header Files

In order to address registers in the supplied C header files, the following rules apply:

1. A register is identified by <peripheral\_instance\_name>.<register\_name>, e.g., CPU.SREG, USART2.CTRLA, or PORTB.DIR.
2. The peripheral name is given in the "Peripheral Address Map" in the "Peripherals and Architecture" section.
3. <peripheral\_instance\_name> is obtained by substituting any n or x in the peripheral name with the correct instance identifier.
4. When assigning a predefined value to a peripheral register, the value is constructed following the rule:  
<peripheral\_name>\_<bit\_field\_name>\_<bit\_field\_value>\_gc  
<peripheral\_name> is <peripheral\_instance\_name>, but remove any instance identifier.  
  
<bit\_field\_value> can be found in the "Name" column in the tables in the Register Description sections describing the bit fields of the peripheral registers.

**Example 5-1. Register Assignments**

```
// EVSYS channel 0 is driven by TCB3 OVF event
EVSYS.CHANNEL0 = EVSYS_CHANNEL0_TCB3_OVF_gc;

// USART0 RXMODE uses Double Transmission Speed
USART0.CTRLB = USART_RXMODE_CLK2X_gc;
```

**Note:** For peripherals with different register sets in different modes, <peripheral\_instance\_name> and <peripheral\_name> must be followed by a mode name, for example:

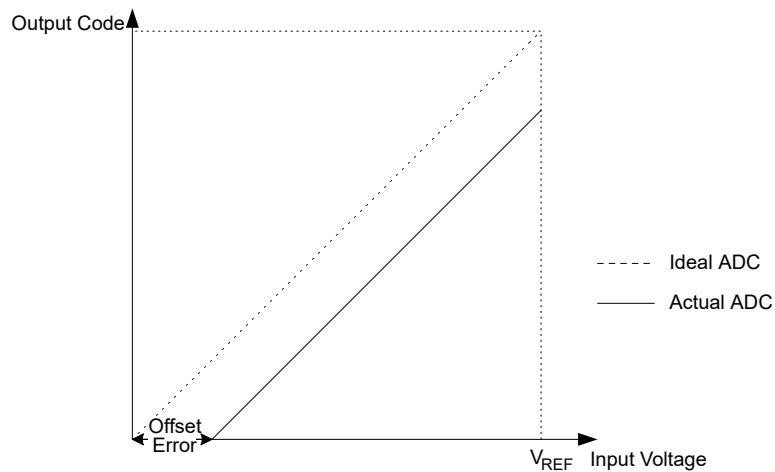
```
// TCA0 in Normal Mode (SINGLE) uses waveform generator in frequency mode
TCA0.SINGLE.CTRL=TCA_SINGLE_WGMODE_FRQ_gc;
```

**5.5 ADC Parameter Definitions**

An ideal n-bit single-ended ADC converts a voltage linearly between GND and  $V_{REF}$  in  $2^n$  steps (LSb). The lowest code is read as '0', and the highest code is read as ' $2^n-1$ '. Several parameters describe the deviation from the ideal behavior:

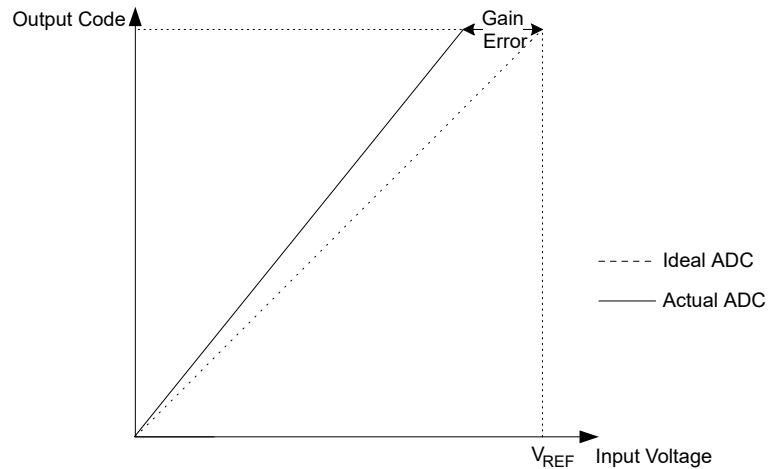
**Offset Error**

The deviation of the first transition (0x000 to 0x001) compared to the ideal transition (at 0.5 LSb). Ideal value: 0 LSb.

**Figure 5-1. Offset Error****Gain Error**

After adjusting for offset, the gain error is found as the deviation of the last transition (e.g., 0x3FE to 0x3FF for a 10-bit ADC) compared to the ideal transition (at 1.5 LSb below maximum). Ideal value: 0 LSb.

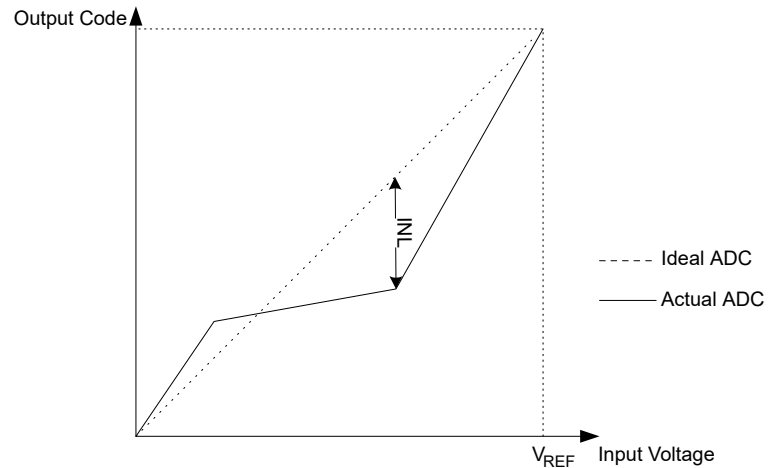
Figure 5-2. Gain Error



**Integral Nonlinearity (INL)**

After adjusting for offset and gain error, the INL is the maximum deviation of an actual transition compared to an ideal transition for any code. Ideal value: 0 LSb.

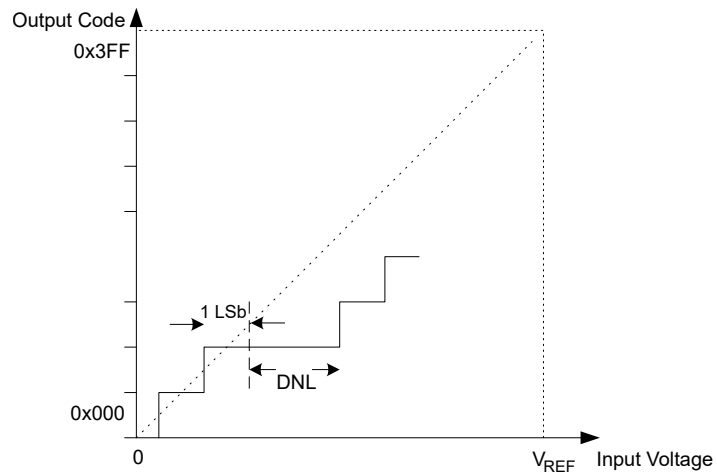
Figure 5-3. Integral Nonlinearity



**Differential Nonlinearity (DNL)**

The maximum deviation of the actual code width (the interval between two adjacent transitions) from the ideal code width (1 LSb). Ideal value: 0 LSb.

Figure 5-4. Differential Nonlinearity



**Quantization Error** Due to the quantization of the input voltage into a finite number of codes, a range of input voltages (1 LSb wide) will code to the same value. Always  $\pm 0.5$  LSb.

**Absolute Accuracy** The maximum deviation of an actual (unadjusted) transition compared to an ideal transition for any code. This is the compound effect of all errors mentioned before. Ideal value:  $\pm 0.5$  LSb.

## 6. AVR® CPU

### 6.1 Features

- 8-bit, High-Performance AVR RISC CPU:
  - 135 instructions
  - Hardware multiplier
- 32 8-bit Registers Directly Connected to the ALU
- Stack in RAM
- Stack Pointer Accessible in I/O Memory Space
- Direct Addressing of up to 64 KB of Unified Memory
- Efficient Support for 8-, 16-, and 32-bit Arithmetic
- Configuration Change Protection for System-Critical Features
- Native On-Chip Debugging (OCD) Support:
  - Two hardware breakpoints
  - Change of flow, interrupt, and software breakpoints
  - Run-time read-out of Stack Pointer (SP) register, Program Counter (PC), and Status Register (SREG)
  - Register file read- and writable in Stopped mode

### 6.2 Overview

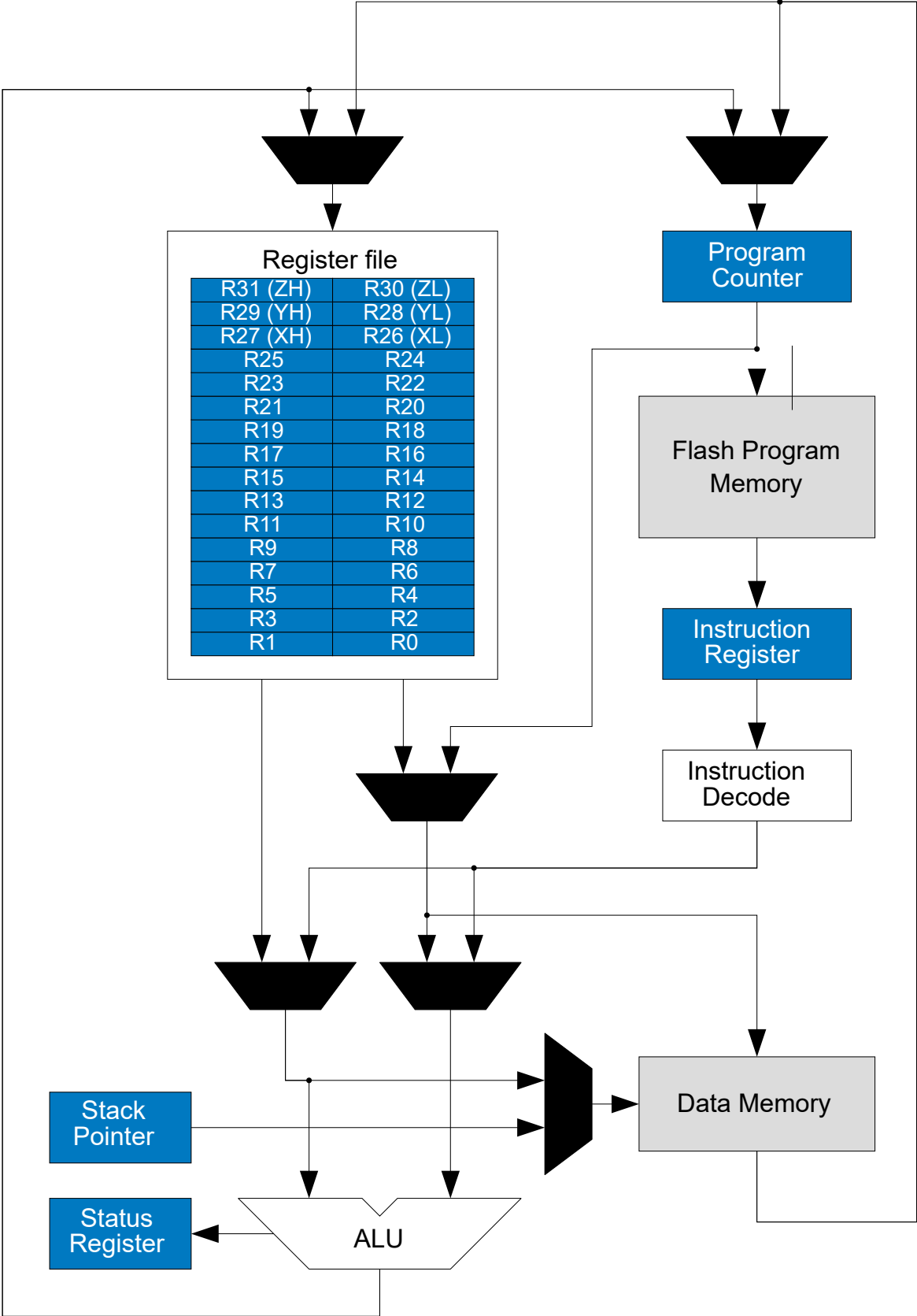
The AVR CPU can access memories, perform calculations, control peripherals, execute instructions from the program memory, and handling interrupts.

### 6.3 Architecture

To maximize performance and parallelism, the AVR CPU uses a Harvard architecture with separate buses for program and data. Instructions in the program memory are executed with a single-level pipeline. While one instruction is being executed, the next instruction is pre-fetched from the program memory. This enables instructions to be executed on every clock cycle.

Refer to the *Instruction Set Summary* section for a summary of all AVR instructions.

Figure 6-1. AVR® CPU Architecture



### 6.3.1 Arithmetic Logic Unit (ALU)

The Arithmetic Logic Unit (ALU) supports arithmetic and logic operations between working registers, or between a constant and a working register. Also, single-register operations can be executed.

The ALU operates in a direct connection with all the 32 general purpose working registers in the register file. Arithmetic operations between working registers or between a working register and an immediate operand are executed in a single clock cycle, and the result is stored in the register file. After an arithmetic or logic operation, the Status Register (CPU.SREG) is updated to reflect information about the result of the operation.

ALU operations are divided into three main categories – arithmetic, logical, and bit functions. Both 8- and 16-bit arithmetic are supported, and the instruction set allows for efficient implementation of the 32-bit arithmetic. The hardware multiplier supports signed and unsigned multiplication and fractional formats.

#### 6.3.1.1 Hardware Multiplier

The multiplier is capable of multiplying two 8-bit numbers into a 16-bit result. The hardware multiplier supports different variations of signed and unsigned integer and fractional numbers:

- Multiplication of signed/unsigned integers
- Multiplication of signed/unsigned fractional numbers
- Multiplication of a signed integer with an unsigned integer
- Multiplication of a signed fractional number with an unsigned fractional number

A multiplication takes two CPU clock cycles.

## 6.4 Functional Description

### 6.4.1 Program Flow

After being reset, the CPU will execute instructions from the lowest address in the Flash program memory, 0x0000.

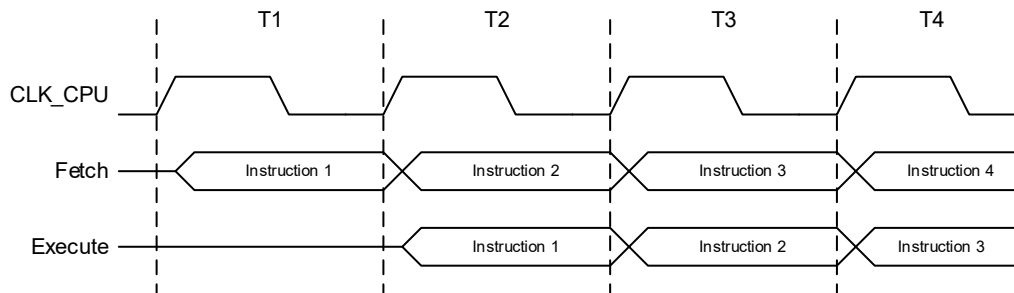
The CPU supports instructions that can change the program flow conditionally or unconditionally and are capable of addressing the whole address space directly. Most AVR instructions use a 16-bit word format, and a limited number use a 32-bit format.

During interrupts and subroutine calls, the return address PC is stored on the stack as a word pointer. The stack is allocated in the general data SRAM, and consequently, the stack size is limited only by the total SRAM size and the usage of the SRAM. After the Stack Pointer (SP) is reset, it points to the highest address in the internal SRAM. The SP is read/write accessible in the I/O memory space, enabling easy implementation of multiple stacks or stack areas. The data SRAM can easily be accessed through different *LD\*/ST\** instructions supported by the AVR CPU. See the *Instruction Set Summary* section for details.

### 6.4.2 Instruction Execution Timing

The AVR CPU is clocked by the CPU clock, CLK\_CPU. No internal clock division is applied. The figure below shows the parallel instruction fetches and executions enabled by the Harvard architecture and the fast-access register file concept. This is a two-stage pipelining concept enabling up to 1 MIPS/MHz performance with high efficiency.

**Figure 6-2. The Parallel Instruction Fetches and Executions**



### 6.4.3 Status Register

The Status Register (CPU.SREG) contains information about the result of the most recently executed arithmetic or logic instructions. This information can be used for altering the program flow to perform conditional operations.

CPU.SREG is updated after all ALU operations, as specified in the *Instruction Set Summary* section. This will, in many cases, remove the need for using the dedicated compare instructions, resulting in a faster and more compact code. CPU.SREG is not automatically stored or restored when entering or returning from an Interrupt Service Routine (ISR). Therefore, maintaining the Status Register between context switches must be handled by user-defined software. CPU.SREG is accessible in the I/O memory space.

### 6.4.4 Stack and Stack Pointer

The stack is used for storing return addresses after interrupts and subroutine calls. Also, it can be used for storing temporary data. The Stack Pointer (SP) always points to the top of the stack. The address pointed to by the SP is stored in the Stack Pointer (CPU.SP) register. CPU.SP is implemented as two 8-bit registers that are accessible in the I/O memory space.

Data are pushed and popped from the stack using the `PUSH` and `POP` instructions. The stack grows from higher to lower memory locations. This means that when pushing data onto the stack, the SP decreases, and when popping data off the stack, the SP increases. The SP is automatically set to the highest address of the internal SRAM after being reset. If the stack is changed, it must be set to point within the SRAM address space (see the SRAM Data Memory section in the Memories section for the SRAM start address), and it must be defined before any subroutine calls are executed and before interrupts are enabled. See the table below for SP details.

**Table 6-1. Stack Pointer Instructions**

Instruction	Stack Pointer	Description
<code>PUSH</code>	Decrement by 1	Data are pushed onto the stack
<code>CALL</code> <code>ICALL</code> <code>EICALL</code> <code>RCALL</code>	Decrement by 2	A return address is pushed onto the stack with a subroutine call or interrupt
<code>POP</code>	Increment by 1	Data are popped from the stack
<code>RET</code> <code>RETI</code>	Increment by 2	A return address is popped from the stack with a return from subroutine or return from interrupt

During interrupts or subroutine calls, the return address is automatically pushed on the stack as a word, and the SP is decremented by two. The return address consists of two bytes, and the Least Significant Byte (LSB) is pushed on the stack first (at the higher address). As an example, a byte pointer return address of 0x0006 is saved on the stack as 0x0003 (shifted one bit to the right), pointing to the fourth 16-bit instruction word in the program memory. The return address is popped off the stack with `RETI` (when returning from interrupts) and `RET` (when returning from subroutine calls), and the SP is incremented by two.

The SP is decremented by one when data are pushed on the stack with the `PUSH` instruction and incremented by one when data are popped off the stack using the `POP` instruction.

To prevent corruption when updating the SP from software, a write to `SPL` will automatically disable interrupts for up to four instructions or until the next I/O memory write, whichever comes first.

### 6.4.5 Register File

The register file consists of 32 8-bit general purpose working registers used by the CPU. The register file is located in a separate address space from the data memory.

All CPU instructions that operate on working registers have direct and single-cycle access to the register file. Some limitations apply to which working registers can be accessed by an instruction, like the constant arithmetic and logic instructions `SBCI`, `SUBI`, `CPI`, `ANDI`, `ORI`, and `LDI`. These instructions apply to the second half of the working registers in the register file, R16 to R31. See the *AVR Instruction Set Manual* for further details.



Figure 6-3. AVR® CPU General Purpose Working Registers

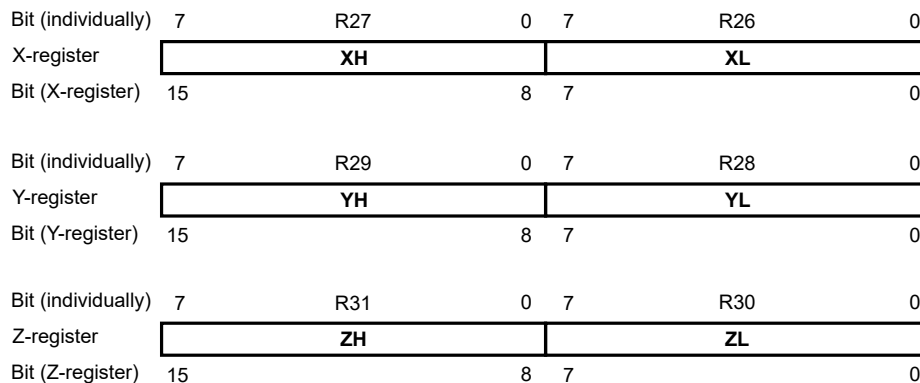
7	0	Addr.	
R0	0x00		
R1	0x01		
R2	0x02		
...			
R13	0x0D		
R14	0x0E		
R15	0x0F		
R16	0x10		
R17	0x11		
...			
R26	0x1A	X-register Low Byte	
R27	0x1B	X-register High Byte	
R28	0x1C	Y-register Low Byte	
R29	0x1D	Y-register High Byte	
R30	0x1E	Z-register Low Byte	
R31	0x1F	Z-register High Byte	

#### 6.4.5.1 The X-, Y-, and Z-Registers

Working registers R26...R31 have added functions besides their general purpose usage.

These registers can form 16-bit Address Pointers for indirect addressing of data memory. These three address registers are called the X-register, Y-register, and Z-register. The Z-register can also be used as Address Pointer for program memory.

Figure 6-4. The X-, Y-, and Z-Registers



The lowest register address holds the Least Significant Byte (LSB), and the highest register address holds the Most Significant Byte (MSB). These address registers can function as fixed displacement, automatic increment, and automatic decrement, with different *LD\*/ST\** instructions. See the *Instruction Set Summary* section for details.

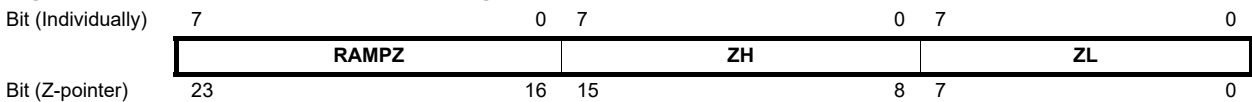
#### 6.4.5.2 Extended Pointers

To access program memory above 64 KB, the Address Pointer must be larger than 16 bits. This is done by concatenating one of the address extension I/O registers (RAMPZ) with the internal Z-pointer. The RAMPZ register then holds the Most Significant Byte (MSB) in a 24-bit address or Address Pointer.

This address extension register is available only on devices with more than 64 KB of program memory. For the devices where extension pointers are required, only the number of bits required to address the whole program and data memory space in the device are implemented.

##### 6.4.5.2.1 Extended Program Memory Pointer

The RAMPZ register is concatenated with the Z-register to enable indirect addressing of the entire program memory.

**Figure 6-5. The Combined RAMPZ + Z Register**

When reading (`ELPM`) above the first 64 KB of the program memory, RAMPZ is concatenated with the Z-register to form the 24-bit address. The `LPM` instruction is not affected by the RAMPZ setting.

## 6.4.6 Configuration Change Protection (CCP)

System critical I/O register settings are protected from accidental modification, and Flash self-programming is protected from accidental programming. This is handled globally by the Configuration Change Protection (CCP) register.

Changes to the protected I/O registers or bits, or execution of protected instructions, are only possible after the CPU writes a signature to the CCP register. The different signatures are listed in the description of the CCP (CPU.CCP) register.

Once the correct signature is written by the CPU, interrupts will be ignored for the duration of the configuration change enable period. Any interrupt request (including non-maskable interrupts) during the CCP period will set the corresponding interrupt flag as normal, and the request is kept pending. After the CCP period is completed, any pending interrupts are executed according to their level and priority.

There are two modes of CCP operation: One for protected I/O registers, and one for protected self-programming.

### 6.4.6.1 Sequence for Write Operation to Configuration Change Protected I/O Registers

To write to I/O registers protected by CCP, the following steps are required:

1. The software writes the signature that enables change of protected I/O registers to the CCP bit field in the CPU.CCP register.
2. Within four instructions, the software must write the appropriate data to the protected I/O register. The protected change is automatically disabled after CPU executes a write instruction.

### 6.4.6.2 Sequence for Execution of Self-Programming

To execute self-programming (the execution of writes to the NVM controller's command register), the following steps are required:

1. The software temporarily enables self-programming by writing the SPM signature to the CCP (CPU.CCP) register.
2. Within four instructions, the software must execute the appropriate instruction or change to NVM Command Register. The protected change is automatically disabled after the CPU executes a write instruction.

## 6.4.7 On-Chip Debug Capabilities

The AVR CPU includes native On-Chip Debug (OCD) support. It includes some powerful debug capabilities to enable profiling and detailed information about the CPU state. It is possible to alter the CPU state and resume code execution. Also, normal debug capabilities like hardware Program Counter breakpoints, breakpoints on change of flow instructions, breakpoints on interrupts, and software breakpoints (`BREAK` instruction) are present. Refer to the *Unified Program and Debug Interface* section for details about OCD.

## 6.5 Register Summary

Offset	Name	Bit Pos.	7	6	5	4	3	2	1	0
0x00 ...	Reserved									
0x03										
0x04	CCP	7:0	CCP[7:0]							
0x05 ...	Reserved									
0x0A										
0x0B	RAMPZ	7:0	RAMPZ[7:0]							
0x0C	Reserved									
0x0D	SP	7:0	SP[7:0]							
		15:8	SP[15:8]							
0x0F	SREG	7:0	I	T	H	S	V	N	Z	C

## 6.6 Register Description

### 6.6.1 Configuration Change Protection

**Name:** CCP  
**Offset:** 0x04  
**Reset:** 0x00  
**Property:** -

Bit	7	6	5	4	3	2	1	0
	CCP[7:0]							
Access	R/W	R/W	R/W	R/W	R/W	R/W	R/W	R/W
Reset	0	0	0	0	0	0	0	0

#### Bits 7:0 – CCP[7:0] Configuration Change Protection

Writing the correct signature to this bit field allows changing protected I/O registers or executing protected instructions within the next four CPU instructions executed.

All interrupts are ignored during these cycles. After these cycles are completed, the interrupts will automatically be handled again by the CPU, and any pending interrupts will be executed according to their level and priority.

When the protected I/O register signature is written, CCP[0] will read as '1' as long as the CCP feature is enabled.

When the protected self-programming signature is written, CCP[1] will read as '1' as long as the CCP feature is enabled.

CCP[7:2] will always read as '0'.

Value	Name	Description
0x9D	SPM	Allow Self-Programming
0xD8	IOREG	Unlock protected I/O registers

## 6.6.2 Stack Pointer

**Name:** SP  
**Offset:** 0x0D  
**Reset:** Top of stack  
**Property:** -

The CPU.SP register holds the Stack Pointer (SP) that points to the top of the stack. After being reset, the SP points to the highest internal SRAM address.

Only the number of bits required to address the available data memory, including external memory (up to 64 KB), is implemented for each device. Unused bits will always read as '0'.

The CPU.SPL and CPU.SPH register pair represents the 16-bit value, CPU.SP. The low byte [7:0] (suffix L) is accessible at the original offset. The high byte [15:8] (suffix H) can be accessed at offset + 0x01.

To prevent corruption when updating the SP from software, a write to CPU.SPL will automatically disable interrupts for the next four instructions or until the next I/O memory write, whichever comes first.

Bit	15	14	13	12	11	10	9	8
	SP[15:8]							
Access	R/W	R/W	R/W	R/W	R/W	R/W	R/W	R/W
Reset								
Bit	7	6	5	4	3	2	1	0
	SP[7:0]							
Access	R/W	R/W	R/W	R/W	R/W	R/W	R/W	R/W
Reset								

**Bits 15:8 – SP[15:8]** Stack Pointer High Byte  
These bits hold the MSB of the 16-bit register.

**Bits 7:0 – SP[7:0]** Stack Pointer Low Byte  
These bits hold the LSB of the 16-bit register.

### 6.6.3 Status Register

**Name:** SREG  
**Offset:** 0x0F  
**Reset:** 0x00  
**Property:** -

The Status Register contains information about the result of the most recently executed arithmetic or logic instructions. For details about the bits in this register and how they are influenced by different instructions, see the *Instruction Set Summary* section.

Bit	7	6	5	4	3	2	1	0
	I	T	H	S	V	N	Z	C
Access	R/W	R/W	R/W	R/W	R/W	R/W	R/W	R/W
Reset	0	0	0	0	0	0	0	0

#### Bit 7 – I Global Interrupt Enable Bit

Writing a '1' to this bit enables interrupts on the device.

Writing a '0' to this bit disables interrupts on the device, independent of the individual interrupt enable settings of the peripherals.

This bit is not cleared by hardware while entering an Interrupt Service Routine (ISR) or set when the RETI instruction is executed.

This bit can be set and cleared by software with the SEI and CLI instructions.

Changing the I bit through the I/O register results in a one-cycle Wait state on the access.

#### Bit 6 – T Transfer Bit

The bit copy instructions, Bit Load (BLD) and Bit Store (BST), use the T bit as source or destination for the operated bit.

#### Bit 5 – H Half Carry Flag

This flag is set when there is a half carry in arithmetic operations that support this, and is cleared otherwise. Half carry is useful in BCD arithmetic.

#### Bit 4 – S Sign Flag

This flag is always an Exclusive Or (XOR) between the Negative flag (N) and the Two's Complement Overflow flag (V).

#### Bit 3 – V Two's Complement Overflow Flag

This flag is set when there is an overflow in arithmetic operations that support this, and is cleared otherwise.

#### Bit 2 – N Negative Flag

This flag is set when there is a negative result in an arithmetic or logic operation, and is cleared otherwise.

#### Bit 1 – Z Zero Flag

This flag is set when there is a zero result in an arithmetic or logic operation, and is cleared otherwise.

#### Bit 0 – C Carry Flag

This flag is set when there is a carry in an arithmetic or logic operation, and is cleared otherwise.

### 6.6.4 Extended Z-Pointer Register

**Name:** RAMPZ  
**Offset:** 0x0B  
**Reset:** 0x00  
**Property:** -

This register is concatenated with the Z-register for indirect addressing (*LD/LDD/ST/STD*) of the whole data memory space on devices with more than 64 KB of data memory. RAMPZ is concatenated with the Z-register when reading the (*ELPM*) program memory locations above the first 64 KB and writing the (*SPM*) program memory locations above the first 128 KB of the program memory.

This register is not available if the data memory and program memory in the device are less than 64 KB.

Bit	7	6	5	4	3	2	1	0
	RAMPZ[7:0]							
Access	R/W	R/W	R/W	R/W	R/W	R/W	R/W	R/W
Reset	0	0	0	0	0	0	0	0

#### Bits 7:0 – RAMPZ[7:0] Extended Z-pointer Address Bits

These bits hold the MSB of the 24-bit address created by RAMPZ and the 16-bit Z-register. Only the number of bits required to address the available data and program memory is implemented for each device. Unused bits will always read as '0'.

## 7. Memories

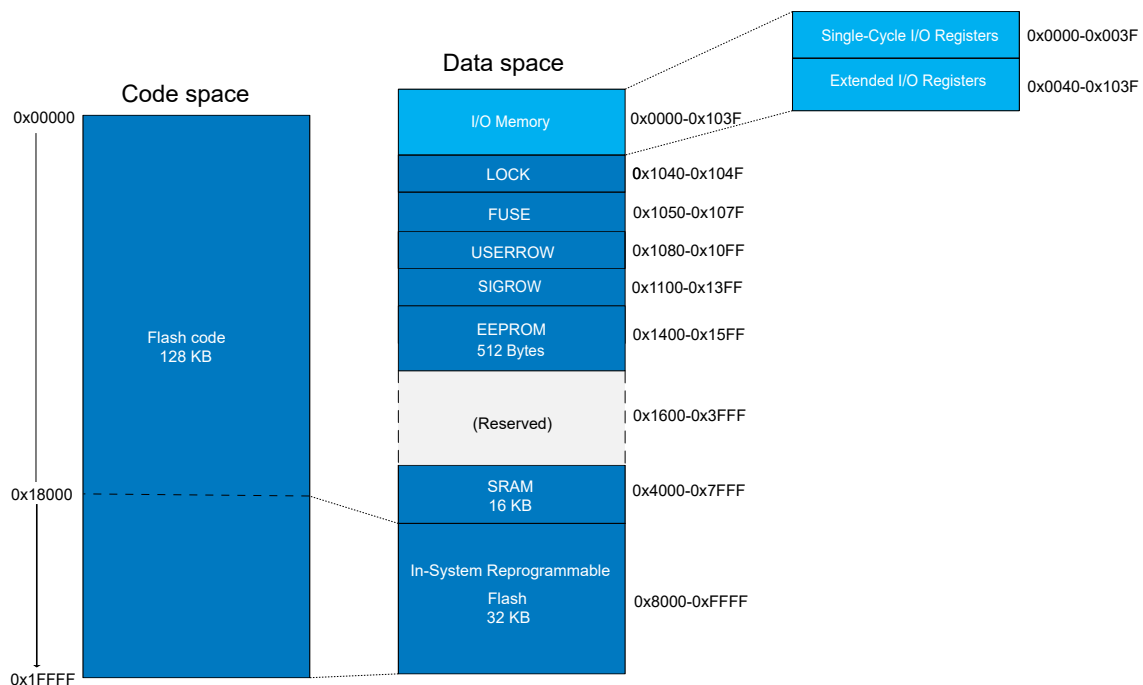
### 7.1 Overview

The main memories of the AVR128DA28/32/48/64 devices are SRAM data memory space, EEPROM data memory space, and Flash program memory space. Also, the peripheral registers are located in the I/O memory space.

### 7.2 Memory Map

The figure below shows the memory map for the largest memory derivative in the AVR® DA family. Refer to the subsequent sections and the *Peripheral Address Map* table for further details.

Figure 7-1. Memory Map



### 7.3 In-System Reprogrammable Flash Program Memory

The AVR128DA28/32/48/64 contains 128 KB on-chip in-system reprogrammable Flash memory for program storage. Since all AVR instructions are 16 or 32 bits wide, the Flash is organized with a 16-bit data width. For write protection, the Flash program memory space can be divided into three sections: Boot Code section, Application Code section, and Application Data section. The code placed in one section may be restricted from writing to addresses in other sections. The Program Counter (PC) is able to address the whole program memory.

Refer to the Code Size (CODESIZE) and Boot Size (BOOTSIZ) descriptions and the *Nonvolatile Memory Controller* section for further details.



The Program Counter can address the whole program memory. The procedure for writing Flash memory is described in detail in the *Nonvolatile Memory Controller (NVMCTRL)* section.

Each 32 KB section from Flash memory can be mapped into the data memory space and will be accessible with `LD/ST` instructions. For `LD/ST` instructions, the Flash is mapped from address 0x8000 to 0xFFFF.

The entire Flash memory space can be also accessed with `LPM/SPM` instruction. For `LPM/SPM` instruction, the Flash start address is 0x0000.

**Table 7-1. Physical Properties of Flash Memory**

Property	AVR128DA28 AVR128DA32 AVR128DA48 AVR128DA64
Size	128 KB
Page size	512B
Number of pages	256
Start address in data space	0x8000
Start address in code space	0x0

## 7.4 SRAM Data Memory

The primary task of the SRAM memory is to store application data. Also, the program stack is located at the end of SRAM. It is not possible to execute from SRAM.

**Table 7-2. Physical Properties of SRAM Memory**

Property	AVR128DA28 AVR128DA32 AVR128DA48 AVR128DA64
Size	16 KB
Start address	0x4000

## 7.5 EEPROM Data Memory

The task of the EEPROM memory is to store nonvolatile application data. The EEPROM memory supports single- and multi-byte read and write. The EEPROM is controlled by the Nonvolatile Memory Controller (NVMCTRL).

**Table 7-3. Physical Properties of EEPROM Memory**

Property	AVR® DA Family
Size	512B
Start address	0x1400

## 7.6 SIGROW - Signature Row

The content of the Signature Row fuses (SIGROW) is pre-programmed and read-only. SIGROW contains information such as device ID, serial number, and calibration values.

All the AVR128DA28/32/48/64 devices have a three-byte device ID that identifies the device. The device ID can be read using the Unified Program and Debug Interface (UPDI), also when a device is locked. The device ID for the AVR128DA28/32/48/64 devices consists of three signature bytes, which is given by the following table.

**Table 7-4. Device ID**

Device Name	Signature Byte Address and Value		
	0x00	0x01	0x02
AVR128DA64	0x1E	0x97	0x07
AVR128DA48	0x1E	0x97	0x08
AVR128DA32	0x1E	0x97	0x09
AVR128DA28	0x1E	0x97	0x0A

## 7.6.1 Signature Row Summary

Offset	Name	Bit Pos.	7	6	5	4	3	2	1	0
0x00	DEVICEID0	7:0	DEVICEID[7:0]							
0x01	DEVICEID1	7:0	DEVICEID[7:0]							
0x02	DEVICEID2	7:0	DEVICEID[7:0]							
0x03	Reserved									
0x04	TEMPSENSE0	7:0	TEMPSENSE[7:0]							
		15:8	TEMPSENSE[15:8]							
0x06	TEMPSENSE1	7:0	TEMPSENSE[7:0]							
		15:8	TEMPSENSE[15:8]							
0x08	Reserved									
...										
0x0F										
0x10	SERNUM0	7:0	SERNUM[7:0]							
...										
0x1F	SERNUM15	7:0	SERNUM[7:0]							

## 7.6.2 Signature Row Description

### 7.6.2.1 Device ID

**Name:** DEVICEIDn  
**Offset:** 0x00 + n\*0x01 [n=0..2]  
**Reset:** [Signature byte n of device ID]  
**Property:** -

Each device has a device ID identifying the device and its properties such as memory sizes and pin count. This can be used to identify a device and hence, the available features by software. The Device ID consists of three bytes: SIGROW.DEVICEID[2:0].

Bit	7	6	5	4	3	2	1	0
	DEVICEID[7:0]							
Access	R	R	R	R	R	R	R	R
Reset	x	x	x	x	x	x	x	x

**Bits 7:0 – DEVICEID[7:0]** Byte n of the Device ID

## 7.6.2.2 Temperature Sensor Calibration n

**Name:** TEMPSENSEn  
**Offset:** 0x04 + n\*0x02 [n=0..1]  
**Reset:** [Temperature sensor calibration value]  
**Property:** -

The Temperature Sensor Calibration value contains correction factors for temperature measurements from the on-chip temperature sensor. The SIGROW.TEMPSENSE0 is a correction factor for the gain/slope (unsigned) and SIGROW.TEMPSENSE1 is a correction factor for the offset (signed).

Bit	15	14	13	12	11	10	9	8
	TEMPSENSE[15:8]							
Access	R	R	R	R	R	R	R	R
Reset	x	x	x	x	x	x	x	x
Bit	7	6	5	4	3	2	1	0
	TEMPSENSE[7:0]							
Access	R	R	R	R	R	R	R	R
Reset	x	x	x	x	x	x	x	x

**Bits 15:0 – TEMPSENSE[15:0]** Temperature Sensor Calibration word n

Refer to the *Analog-to-Digital Converter* section for a description of how to use the value stored in this bit field.

### 7.6.2.3 Serial Number Byte n

**Name:** SERNUMn  
**Offset:** 0x10 + n\*0x01 [n=0..15]  
**Reset:** [Byte n of device serial number]  
**Property:** -

Each device has an individual serial number, representing a unique ID. This can be used to identify a specific device in the field. The serial number consists of 16 bytes: SIGROW.SERNUM[15:0].

Bit	7	6	5	4	3	2	1	0
	SERNUM[7:0]							
Access	R	R	R	R	R	R	R	R
Reset	x	x	x	x	x	x	x	x

**Bits 7:0 – SERNUM[7:0]** Serial Number Byte n

## 7.7 USERROW - User Row

The AVR128DA28/32/48/64 devices have a special 32-byte memory section called the User Row (USERROW). The USERROW can be used for end-production data and is not affected by chip erase. It can be written by the Unified Program and Debug Interface (UPDI) even if the part is locked, which enables storage of final configuration without having access to any other memory. When the part is locked, the UPDI is not allowed to read the content of the USERROW.

The CPU can write and read this memory as a normal Flash. Refer to the *System Memory Address Map* for further details.

## 7.8 FUSE - Configuration and User Fuses

Fuses are part of the nonvolatile memory and hold factory calibration and device configuration. The fuses can be read by the CPU or the UPDI, but can only be programmed or cleared by the UPDI. The configuration values stored in the fuses are written to their respective target registers at the end of the start-up sequence.

The fuses for peripheral configuration (FUSE) are preprogrammed but can be altered by the user. Altered values in the configuration fuse will be effective only after a Reset.

**Note:** When writing the fuses, all reserved bits must be written to '0'.

## 7.8.1 Fuse Summary

Offset	Name	Bit Pos.	7	6	5	4	3	2	1	0
0x00	WDTCFG	7:0	WINDOW[3:0]				PERIOD[3:0]			
0x01	BODCFG	7:0	LVL[2:0]		SAMPFREQ	ACTIVE[1:0]		SLEEP[1:0]		
0x02	OSCCFG	7:0					CLKSEL[3:0]			
0x03	Reserved									
...										
0x04										
0x05	SYSCFG0	7:0	CRCSRC[1:0]		CRCSEL	RSTPINCFG[1:0]		EESAVE		
0x06	SYSCFG1	7:0					SUT[2:0]			
0x07	CODESIZE	7:0	CODESIZE[7:0]							
0x08	BOOTSIZ	7:0	BOOTSIZ[7:0]							

## 7.8.2 Fuse Description

### 7.8.2.1 Watchdog Configuration

**Name:** WDTCFG  
**Offset:** 0x00  
**Default:** 0x00  
**Property:** -

The default value given in this fuse description is the factory-programmed value, and should not be mistaken for the Reset value.

Bit	7	6	5	4	3	2	1	0
	WINDOW[3:0]				PERIOD[3:0]			
Access	R	R	R	R	R	R	R	R
Default	0	0	0	0	0	0	0	0

**Bits 7:4 – WINDOW[3:0]** Watchdog Window Time-out Period

This value is loaded into the WINDOW bit field of the Watchdog Control A (WDT.CTRLA) register during Reset.

**Bits 3:0 – PERIOD[3:0]** Watchdog Time-out Period

This value is loaded into the PERIOD bit field of the Watchdog Control A (WDT.CTRLA) register during Reset.



## 7.8.2.2 Brown-out Detector Configuration

**Name:** BODCFG  
**Offset:** 0x01  
**Default:** 0x00  
**Property:** -

The bit values of this fuse register are written to the corresponding BOD configuration registers at power-up.

The default value given in this fuse description is the factory-programmed value, and should not be mistaken for the Reset value.

Bit	7	6	5	4	3	2	1	0
	LVL[2:0]			SAMPFREQ	ACTIVE[1:0]		SLEEP[1:0]	
Access	R	R	R	R	R	R	R	R
Default	0	0	0	0	0	0	0	0

**Bits 7:5 – LVL[2:0]** BOD Level

This value is loaded into the LVL bit field of the BOD Control B (BOD.CTRLB) register during Reset.

Value	Name	Description
0x0	BODLEVEL0	1.9V
0x1	BODLEVEL1	2.45V
0x2	BODLEVEL2	2.70V
0x3	BODLEVEL3	2.85V
Other	-	Reserved

**Notes:**

- Refer to *BOD and POR Characteristics* in the *Electrical Characteristics* section for further details
- Values in the description are typical values

**Bit 4 – SAMPFREQ** BOD Sample Frequency

This value is loaded into the Sample Frequency (SAMPFREQ) bit of the BOD Control A (BOD.CTRLA) register during Reset. Refer to the *Brown-out Detector* section for further details.

Value	Name	Description
0x0	128HZ	The sample frequency is 128 Hz
0x1	32HZ	The sample frequency is 32 Hz

**Bits 3:2 – ACTIVE[1:0]** BOD Operation Mode in Active and Idle

This value is loaded into the ACTIVE bit field of the BOD Control A (BOD.CTRLA) register during Reset. Refer to the *Brown-out Detector* section for further details.

Value	Name	Description
0x0	DISABLE	BOD disabled
0x1	ENABLE	BOD enabled in Continuous mode
0x2	SAMPLE	BOD enabled in Sampled mode
0x3	ENABLEWAIT	BOD enabled in Continuous mode. Execution is halted at wake-up until BOD is running.

**Bits 1:0 – SLEEP[1:0]** BOD Operation Mode in Sleep

The value is loaded into the SLEEP bit field of the BOD Control A (BOD.CTRLA) register during Reset. Refer to the *Brown-out Detector* section for further details.

Value	Name	Description
0x0	DISABLE	BOD disabled
0x1	ENABLE	BOD enabled in Continuous mode
0x2	SAMPLE	BOD enabled in Sampled mode
0x3	-	Reserved

### 7.8.2.3 Oscillator Configuration

**Name:** OSCCFG  
**Offset:** 0x02  
**Default:** 0x00  
**Property:** -

The default value given in this fuse description is the factory-programmed value, and should not be mistaken for the Reset value.

Bit	7	6	5	4	3	2	1	0
					CLKSEL[3:0]			
Access					R	R	R	R
Default					0	0	0	0

#### Bits 3:0 – CLKSEL[3:0] Clock Select

This bit field controls the default oscillator of the device.

Value	Name	Description
0x0	OSCHF	Device running on internal high-frequency oscillator
0x1	OSC32K	Device running on internal 32.768 kHz oscillator
Other	-	Reserved

## 7.8.2.4 System Configuration 0

**Name:** SYSCFG0  
**Offset:** 0x05  
**Default:** 0xC0  
**Property:** -

The default value given in this fuse description is the factory-programmed value, and should not be mistaken for the Reset value.

Bit	7	6	5	4	3	2	1	0
	CRCSRC[1:0]		CRCSEL		RSTPINCFG[1:0]			EESAVE
Access	R	R	R		R	R		R
Default	1	1	0		0	0		0

**Bits 7:6 – CRCSRC[1:0]** CRC Source

This bit field control which section of the Flash will be checked by the CRCSCAN peripheral after Reset. Refer to the *CRCSCAN* section for more information about the functionality.

Value	Name	Description
0x0	FLASH	CRC of full Flash (boot, application code, and application data)
0x1	BOOT	CRC of the Boot section
0x2	BOOTAPP	CRC of the Application code and Boot sections
0x3	NOCRC	No CRC

**Bit 5 – CRCSEL** CRC Mode Selection

This bit controls the type of CRC performed by the CRCSCAN peripheral. Refer to the *CRCSCAN* section for more information about the functionality.

Value	Name	Description
0x0	CRC16	CRC-16-CCITT
0x1	CRC32	CRC-32 (IEEE 802.3)

**Bits 3:2 – RSTPINCFG[1:0]** Reset Pin Configuration

This bit field controls the pin configuration of the Reset pin.

Value	Name	Description
0x0	INPUT	PF6 configured as general input pin.
0x1	-	Reserved
0x2	RESET	External Reset enabled on PF6
0x3	-	Reserved

**Bit 0 – EESAVE** EEPROM Save During Chip Erase

This bit controls if the EEPROM will be erased or not during a Chip Erase. If the device is locked, the EEPROM is always erased by a Chip Erase regardless of this bit.

Value	Description
0	EEPROM erased during Chip Erase
1	EEPROM not erased under Chip Erase

## 7.8.2.5 System Configuration 1

**Name:** SYSCFG1  
**Offset:** 0x06  
**Default:** 0x00  
**Property:** -

The default value given in this fuse description is the factory-programmed value, and should not be mistaken for the Reset value.

Bit	7	6	5	4	3	2	1	0
						SUT[2:0]		
Access						R	R	R
Default						0	0	0

**Bits 2:0 – SUT[2:0]** Start-up Time

This bit field controls the start-up time between power-on and code execution.

Value	Description
0x0	0 ms
0x1	1 ms
0x2	2 ms
0x3	4 ms
0x4	8 ms
0x5	16 ms
0x6	32 ms
0x7	64 ms

**7.8.2.6 Code Size**

**Name:** CODESIZE  
**Offset:** 0x07  
**Default:** 0x00  
**Property:** -

The default value given in this fuse description is the factory-programmed value, and should not be mistaken for the Reset value.

Bit	7	6	5	4	3	2	1	0
	CODESIZE[7:0]							
Access	R	R	R	R	R	R	R	R
Default	0	0	0	0	0	0	0	0

**Bits 7:0 – CODESIZE[7:0] Code Section Size**

This bit field controls the combined size of the Boot Code section and Application Code section in blocks of 512 bytes. For more details, refer to the *Nonvolatile Memory Controller* section.

**Note:** If FUSE.BOOTSIZE is 0x00, the entire Flash is the Boot Code section.

7.8.2.7 Boot Size

**Name:** BOOTSIZ  
**Offset:** 0x08  
**Default:** 0x00  
**Property:** -

The default value given in this fuse description is the factory-programmed value, and should not be mistaken for the Reset value.

Bit	7	6	5	4	3	2	1	0
	BOOTSIZ[7:0]							
Access	R	R	R	R	R	R	R	R
Default	0	0	0	0	0	0	0	0

**Bits 7:0 – BOOTSIZ[7:0]** Boot Section Size

This bit field controls the size of the boot section in blocks of 512 bytes. A value of 0x00 defines the entire Flash as Boot Code section.

For more details, refer to the *Nonvolatile Memory Controller* section.

7.9 LOCK - Memory Sections Access Protection

The device can be locked so that the memories cannot be read using the Unified Program and Debug Interface (UPDI). The locking protects both the Flash (all Boot Code, Application Code, and Application Data sections), SRAM, and the EEPROM including the FUSE data. This prevents the reading of application data or code using the debugger interface. Regular memory access from within the application is still enabled.

The device is locked by writing a non-valid key to the Lock Key (LOCK.KEY) register.

**Table 7-5. Memory Access Unlocked (LOCK.KEY Valid Key)<sup>(1)</sup>**

Memory Section	CPU Access		UPDI Access	
	Read	Write	Read	Write
Flash	Yes	Yes	Yes	Yes
SRAM	Yes	Yes	Yes	Yes
EEPROM	Yes	Yes	Yes	Yes
SIGROW	Yes	No	Yes	No
USERROW	Yes	Yes	Yes	Yes
FUSE	Yes	No	Yes	Yes
LOCK	Yes	No	Yes	Yes
Registers	Yes	Yes	Yes	Yes

**Table 7-6. Memory Access Locked (LOCK.KEY Invalid Key)<sup>(1)</sup>**

Memory Section	CPU Access		UPDI Access	
	Read	Write	Read	Write
Flash	Yes	Yes	No	No
SRAM	Yes	Yes	No	No
EEPROM	Yes	Yes	No	No
SIGROW	Yes	No	No	No

.....continued

Memory Section	CPU Access		UPDI Access	
	Read	Write	Read	Write
USERROW	Yes	Yes	No	Yes <sup>(2)</sup>
FUSE	Yes	No	No	No
LOCK	Yes	No	No	No
Registers	Yes	Yes	No	No

**Notes:**

1. Read operations marked No in the tables may appear to be successful, but the data is not valid. Hence, any attempt of code validation through the UPDI will fail on these memory sections.
2. In the Locked mode, the USERROW can be written using the Fuse Write command, but the current USERROW values cannot be read out.



**Important:** The only way to unlock a device is a CHIPERASE. No application data is retained.

### 7.9.1 Lock Summary

Offset	Name	Bit Pos.	7	6	5	4	3	2	1	0
0x00	KEY	7:0	KEY[7:0]							
		15:8	KEY[15:8]							
		23:16	KEY[23:16]							
		31:24	KEY[31:24]							

### 7.9.2 Lock Description



## 7.9.2.1 Lock Key

**Name:** KEY  
**Offset:** 0x00  
**Reset:** Initial factory value 0x5CC5C55C  
**Property:** -

Bit	31	30	29	28	27	26	25	24
	KEY[31:24]							
Access	R	R	R	R	R	R	R	R
Reset	x	x	x	x	x	x	x	x
Bit	23	22	21	20	19	18	17	16
	KEY[23:16]							
Access	R	R	R	R	R	R	R	R
Reset	x	x	x	x	x	x	x	x
Bit	15	14	13	12	11	10	9	8
	KEY[15:8]							
Access	R	R	R	R	R	R	R	R
Reset	x	x	x	x	x	x	x	x
Bit	7	6	5	4	3	2	1	0
	KEY[7:0]							
Access	R	R	R	R	R	R	R	R
Reset	x	x	x	x	x	x	x	x

**Bits 31:0 – KEY[31:0]** Lock Key

This bit field controls whether the device is locked or not.

Value	Name	Description
0x5CC5C55C	UNLOCKED	Device unlocked
Other	LOCKED	Device locked

## 7.10 I/O Memory

All AVR128DA28/32/48/64 devices I/O and peripheral registers are located in the I/O memory space. Refer to the *Peripheral Address Map* table for further details.

For compatibility with a future device, if a register containing reserved bits is written, the reserved bits should be written to '0'. Reserved I/O memory addresses should never be written.

## 7.10.1 Single-Cycle I/O Registers

The I/O memory ranging from 0x00 to 0x3F can be accessed by a single-cycle CPU instruction using the `IN` or `OUT` instructions.

The peripherals available in the single-cycle I/O registers are as follows:

- VPORTx
  - Refer to the *I/O Configuration* section for further details
- GPR
  - Refer to the *General Purpose Registers* section for further details
- CPU
  - Refer to the *AVR CPU* section for further details

The single-cycle I/O registers ranging from 0x00 to 0x1F (VPORTx and GPR) are also directly bit-accessible using the *SBI* or *CBI* instruction. In these single-cycle I/O registers, single bits can be checked by using the *SBIS* or *SBIC* instruction.

Refer to the *Instruction Set Summary* section for further details.

### 7.10.2 Extended I/O Registers

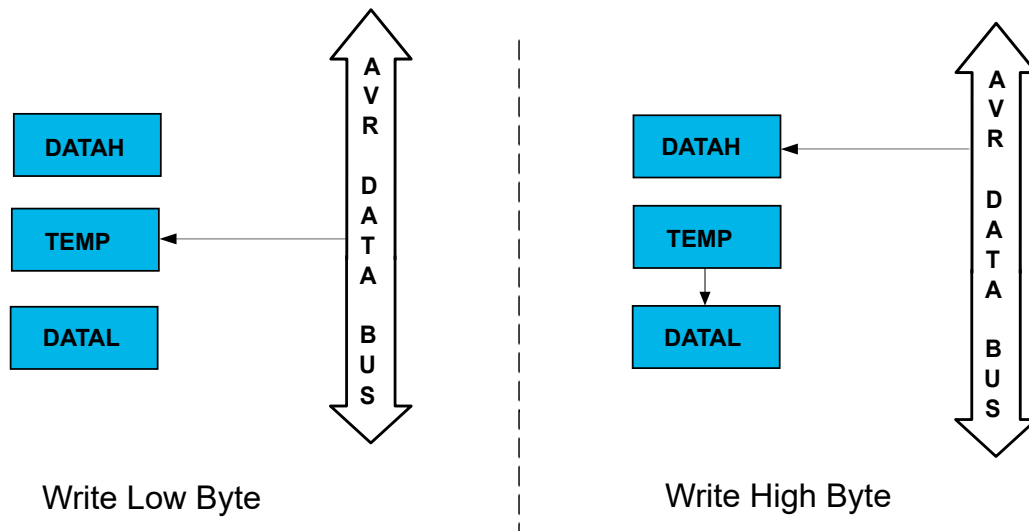
The I/O memory space ranging from 0x0040 to 0x103F can only be accessed by the *LD/LDS/LDD* or *ST/STS/STD* instructions, transferring data between the 32 general purpose working registers (R0-R31) and the I/O memory space.

Refer to the *Peripheral Address Map* table and the *Instruction Set Summary* section for further details.

### 7.10.3 Accessing 16-bit Registers

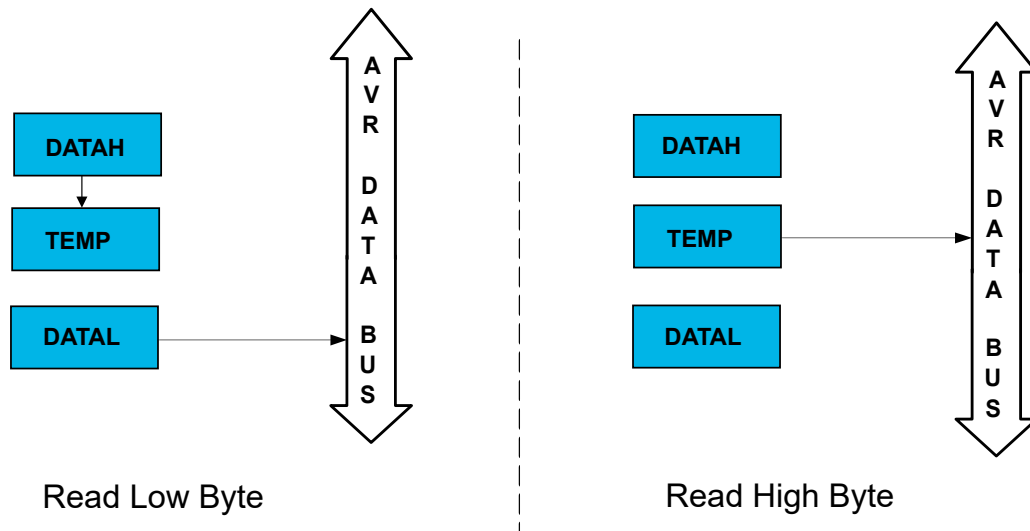
Most of the registers for the AVR128DA28/32/48/64 devices are 8-bit registers, but the devices also feature a few 16-bit registers. As the AVR data bus has a width of eight bits, accessing the 16-bit requires two read or write operations. All the 16-bit registers of the AVR128DA28/32/48/64 devices are connected to the 8-bit bus through a temporary (TEMP) register.

**Figure 7-2. 16-Bit Register Write Operation**



For a 16-bit write operation, the low byte register (e.g., DATAL) of the 16-bit register must be written before the high byte register (e.g., DATAH). Writing the low byte register will result in a write to the temporary (TEMP) register instead of the low byte register, as shown in the left side of [Figure 7-2](#). When the high byte register of the 16-bit register is written, TEMP will be copied into the low byte of the 16-bit register in the same clock cycle, as shown on the right side of [Figure 7-2](#).

Figure 7-3. 16-Bit Register Read Operation



For a 16-bit read operation, the low byte register (e.g., DATAL) of the 16-bit register must be read before the high byte register (e.g., DATAH). When the low byte register is read, the high byte register of the 16-bit register is copied into the temporary (TEMP) register in the same clock cycle, as shown on the left side of [Figure 7-3](#). Reading the high byte register will result in a read from TEMP instead of the high byte register, as shown on the right side of [Figure 7-3](#).

The described mechanism ensures that the low and high bytes of 16-bit registers are always accessed simultaneously when reading or writing the registers.

Interrupts can corrupt the timed sequence if an interrupt is triggered during a 16-bit read/write operation, and a 16-bit register within the same peripheral is accessed in the interrupt service routine. To prevent this, interrupts should be disabled when writing or reading 16-bit registers. Alternatively, the temporary register can be read before and restored after the 16-bit access in the interrupt service routine.

#### 7.10.4 Accessing 24-Bit Registers

For 24-bit registers, the read and write access is done in the same way as described for 16-bit registers, except there are two temporary registers for 24-bit registers. The Most Significant Byte must be written last when writing to the register, and the Least Significant Byte must be read first when reading the register.

## 8. Peripherals and Architecture

### 8.1 Peripheral Address Map

The address map shows the base address for each peripheral. For complete register description and summary for each peripheral, refer to the respective peripheral sections.

**Table 8-1. Peripheral Address Map**

Base Address	Name	Description	28-Pin	32-Pin	48-Pin	64-Pin
0x0000	VPORTA	Virtual Port A	X	X	X	X
0x0004	VPORTB	Virtual Port B			X	X
0x0008	VPORTC	Virtual Port C	X	X	X	X
0x000C	VPORTD	Virtual Port D	X	X	X	X
0x0010	VPORTE	Virtual Port E			X	X
0x0014	VPORTF	Virtual Port F	X	X	X	X
0x0018	VPORTG	Virtual Port G				X
0x001C	GPR	General Purpose Registers	X	X	X	X
0x0030	CPU	CPU	X	X	X	X
0x0040	RSTCTRL	Reset Controller	X	X	X	X
0x0050	SLPCTRL	Sleep Controller	X	X	X	X
0x0060	CLKCTRL	Clock Controller	X	X	X	X
0x0080	BOD	Brown-out Detector	X	X	X	X
0x00A0	VREF	Voltage Reference	X	X	X	X
0x0100	WDT	Watchdog Timer	X	X	X	X
0x0110	CPUINT	Interrupt Controller	X	X	X	X
0x0120	CRCSKAN	Cyclic Redundancy Check Memory Scan	X	X	X	X
0x0140	RTC	Real-Time Counter	X	X	X	X
0x01C0	CCL	Configurable Custom Logic	X	X	X	X
0x0200	EVSYS	Event System	X	X	X	X
0x0400	PORTA	Port A Configuration	X	X	X	X
0x0420	PORTB	Port B Configuration			X	X
0x0440	PORTC	Port C Configuration	X	X	X	X
0x0460	PORTD	Port D Configuration	X	X	X	X
0x0480	PORTE	Port E Configuration			X	X
0x04A0	PORTF	Port F Configuration	X	X	X	X
0x04C0	PORTG	Port G Configuration				X
0x05E0	PORTMUX	Port Multiplexer	X	X	X	X

.....continued

Base Address	Name	Description	28-Pin	32-Pin	48-Pin	64-Pin
0x0600	ADC0	Analog-to-Digital Converter 0	X	X	X	X
0x0680	AC0	Analog Comparator 0	X	X	X	X
0x0688	AC1	Analog Comparator 1	X	X	X	X
0x0690	AC2	Analog Comparator 2	X	X	X	X
0x06A0	DAC0	Digital-to-Analog converter 0	X	X	X	X
0x06C0	ZCD0	Zero-Cross Detector 0	X	X	X	X
0x06C8	ZCD1	Zero-Cross Detector 1			X	X
0x06D0	ZCD2	Zero-Cross Detector 2				X
0x07C0	PTC	Peripheral Touch Controller	X	X	X	X
0x0800	USART0	Universal Synchronous Asynchronous Receiver Transmitter 0	X	X	X	X
0x0820	USART1	Universal Synchronous Asynchronous Receiver Transmitter 1	X	X	X	X
0x0840	USART2	Universal Synchronous Asynchronous Receiver Transmitter 2	X	X	X	X
0x0860	USART3	Universal Synchronous Asynchronous Receiver Transmitter 3			X	X
0x0880	USART4	Universal Synchronous Asynchronous Receiver Transmitter 4			X	X
0x08A0	USART5	Universal Synchronous Asynchronous Receiver Transmitter 5				X
0x0900	TWI0	Two-Wire Interface 0	X	X	X	X
0x0920	TWI1	Two-Wire Interface 1		X	X	X
0x0940	SPI0	Serial Peripheral Interface 0	X	X	X	X
0x0960	SPI1	Serial Peripheral Interface 1	X	X	X	X
0x0A00	TCA0	Timer/Counter Type A instance 0	X	X	X	X
0x0A40	TCA1	Timer/Counter Type A instance 1			X	X
0x0B00	TCB0	Timer/Counter Type B instance 0	X	X	X	X
0x0B10	TCB1	Timer/Counter Type B instance 1	X	X	X	X
0x0B20	TCB2	Timer/Counter Type B instance 2	X	X	X	X
0x0B30	TCB3	Timer/Counter Type B instance 3			X	X
0x0B40	TCB4	Timer/Counter Type B instance 4				X
0x0B80	TCD0	Timer/Counter Type D instance 0	X	X	X	X
0x0F00	SYSCFG	System Configuration	X	X	X	X
0x1000	NVMCTRL	Nonvolatile Memory Controller	X	X	X	X

**Table 8-2. System Memory Address Map**

Base Address	Name	Description	28-Pin	32-Pin	48-Pin	64-Pin
0x1040	LOCK	Lock Bits	X	X	X	X
0x1050	FUSE	User Configuration	X	X	X	X
0x1080	USERROW	User Row	X	X	X	X
0x1100	SIGROW	Signature Row	X	X	X	X

## 8.2 Interrupt Vector Mapping

Each of the interrupt vectors is connected to one peripheral instance, as shown in the table below. A peripheral can have one or more interrupt sources. For more details on the available interrupt sources, see the *Interrupt* section in the *Functional Description* of the respective peripheral.

An interrupt flag is set in the Interrupt Flags register of the peripheral (`peripheral.INTFLAGS`) when the interrupt condition occurs, even if the interrupt is not enabled.

An interrupt is enabled or disabled by writing to the corresponding Interrupt Enable bit in the peripheral's Interrupt Control register (`peripheral.INTCTRL`).

An interrupt request is generated when the corresponding interrupt is enabled, and the interrupt flag is set. Interrupts must be enabled globally for interrupt request to be generated. The interrupt request remains active until the interrupt flag is cleared. See the peripheral's `INTFLAGS` register for details on how to clear interrupt flags.

**Table 8-3. Interrupt Vector Mapping**

Vector Number	Program Address (word)	Peripheral Source	28-Pin	32-Pin	48-Pin	64-Pin
0	0x00	RESET	X	X	X	X
1	0x02	NMI	X	X	X	X
2	0x04	VLM - Voltage Level Monitor	X	X	X	X
3	0x06	RTC - Overflow or compare match	X	X	X	X
4	0x08	PIT - Periodic interrupt	X	X	X	X
5	0x0A	CCL - Configurable Custom Logic	X	X	X	X
6	0x0C	PORTA - External interrupt	X	X	X	X
7	0x0E	TCA0 - Overflow	X	X	X	X
8	0x10	TCA0 - Underflow	X	X	X	X
9	0x12	TCA0 - Compare 0	X	X	X	X
10	0x14	TCA0 - Compare 1	X	X	X	X
11	0x16	TCA0 - Compare 2	X	X	X	X
12	0x18	TCB0 - Capture/Overflow	X	X	X	X
13	0x1A	TCB1 - Capture/Overflow	X	X	X	X
14	0x1C	TCD0 - Overflow	X	X	X	X
15	0x1E	TCD0 - Trigger	X	X	X	X
16	0x20	TWI0 - Slave	X	X	X	X

# AVR128DA28/32/48/64

## Peripherals and Architecture

.....continued						
Vector Number	Program Address (word)	Peripheral Source	28-Pin	32-Pin	48-Pin	64-Pin
17	0x22	TWI0 - Master	X	X	X	X
18	0x24	SPI0	X	X	X	X
19	0x26	USART0 - Receive Complete	X	X	X	X
20	0x28	USART0 - Data Register Empty	X	X	X	X
21	0x2A	USART0 - Transmit Complete	X	X	X	X
22	0x2C	PORTD - External Interrupt	X	X	X	X
23	0x2E	AC0 - Compare	X	X	X	X
24	0x30	ADC0 - Result Ready	X	X	X	X
25	0x32	ADC0 - Window Compare	X	X	X	X
26	0x34	ZCD0 - Cross	X	X	X	X
27	0x36	PTC - Result Ready	X	X	X	X
28	0x38	AC1 - Compare	X	X	X	X
29	0x3A	PORTC - External Interrupt	X	X	X	X
30	0x3C	TCB2 - Capture/Overflow	X	X	X	X
31	0x3E	USART1 - Receive Complete	X	X	X	X
32	0x40	USART1 - Data Register Empty	X	X	X	X
33	0x42	USART1 - Transmit Complete	X	X	X	X
34	0x44	PORTF - External Interrupt	X	X	X	X
35	0x46	NVM - Ready	X	X	X	X
36	0x48	SPI1	X	X	X	X
37	0x4A	USART2 - Receive Complete	X	X	X	X
38	0x4C	USART2 - Data Register Empty	X	X	X	X
39	0x4E	USART2 - Transmit Complete	X	X	X	X
40	0x50	AC2 - Compare	X	X	X	X
41	0x52	TCB3 - Capture/Overflow			X	X
42	0x54	TWI1 - Slave		X	X	X
43	0x56	TWI1 - Master		X	X	X
44	0x58	PORTB - External Interrupt			X	X
45	0x5A	PORTE - External Interrupt			X	X
46	0x5C	TCA1 - Overflow			X	X
47	0x5E	TCA1 - Underflow			X	X
48	0x60	TCA1 - Compare 0			X	X
49	0x62	TCA1 - Compare 1			X	X
50	0x64	TCA1 - Compare 2			X	X

.....continued

Vector Number	Program Address (word)	Peripheral Source	28-Pin	32-Pin	48-Pin	64-Pin
51	0x66	ZCD1 - Zero cross			X	X
52	0x68	USART3 - Receive Complete			X	X
53	0x6A	USART3 - Data Register Empty			X	X
54	0x6C	USART3 - Transmit Complete			X	X
55	0x6E	USART4 - Receive Complete			X	X
56	0x70	USART4 - Data Register Empty			X	X
57	0x72	USART4 - Transmit Complete			X	X
58	0x74	PORTG - External Interrupt				X
59	0x76	ZCD2 - Cross				X
60	0x78	TCB4 - Capture/Overflow				X
61	0x7A	USART5 - Receive Complete				X
62	0x7C	USART5 - Data Register Empty				X
63	0x7E	USART5 - Transmit Complete				X

### 8.3 SYSCFG - System Configuration

The system configuration contains the revision ID of the part. The revision ID is readable from the CPU, making it useful for implementing application changes between part revisions.



**8.3.1 Register Summary**

Offset	Name	Bit Pos.	7	6	5	4	3	2	1	0
0x00	Reserved									
0x01	REVID	7:0	MAJOR[3:0]				MINOR[3:0]			

**8.3.2 Register Description**

### 8.3.2.1 Device Revision ID Register

**Name:** REVID  
**Offset:** 0x01  
**Reset:** [revision ID]  
**Property:** -

This register is read-only and give the device revision ID.

Bit	7	6	5	4	3	2	1	0
	MAJOR[3:0]				MINOR[3:0]			
Access	R	R	R	R	R	R	R	R
Reset	x	x	x	x	x	x	x	x

**Bits 7:4 – MAJOR[3:0]** Major revision

This bit field contains the major revision for the device. 0x00 = A, 0x01 = B, and so on.

**Bits 3:0 – MINOR[3:0]** Minor revision

This bit field contains the minor revision for the device. 0x00 = 0, 0x01 = 1, and so on.

## **9. GPR - General Purpose Registers**

The AVR128DA28/32/48/64 devices provide four General Purpose Registers. These registers can be used for storing any information, and they are particularly useful for storing global variables and interrupt flags. General Purpose Registers, which reside in the address range 0x1C - 0x1F, are directly bit-accessible using the `SBI`, `CBI`, `SBIS`, and `SBIC` instructions.

## 9.1 Register Summary

Offset	Name	Bit Pos.	7	6	5	4	3	2	1	0	
0x00	<a href="#">GPR0</a>	7:0	GPR[7:0]								
0x01	<a href="#">GPR1</a>	7:0	GPR[7:0]								
0x02	<a href="#">GPR2</a>	7:0	GPR[7:0]								
0x03	<a href="#">GPR3</a>	7:0	GPR[7:0]								

## 9.2 Register Description

### 9.2.1 General Purpose Register n

**Name:** GPRn  
**Offset:** 0x00 + n\*0x01 [n=0..3]  
**Reset:** 0x00  
**Property:** -

These are general purpose registers that can be used to store data, such as global variables and flags, in the bit accessible I/O memory space.

Bit	7	6	5	4	3	2	1	0
	GPR[7:0]							
Access	R/W	R/W	R/W	R/W	R/W	R/W	R/W	R/W
Reset	0	0	0	0	0	0	0	0

**Bits 7:0 – GPR[7:0]** General Purpose Register Byte

## **10. NVMCTRL - Nonvolatile Memory Controller**

### **10.1 Features**

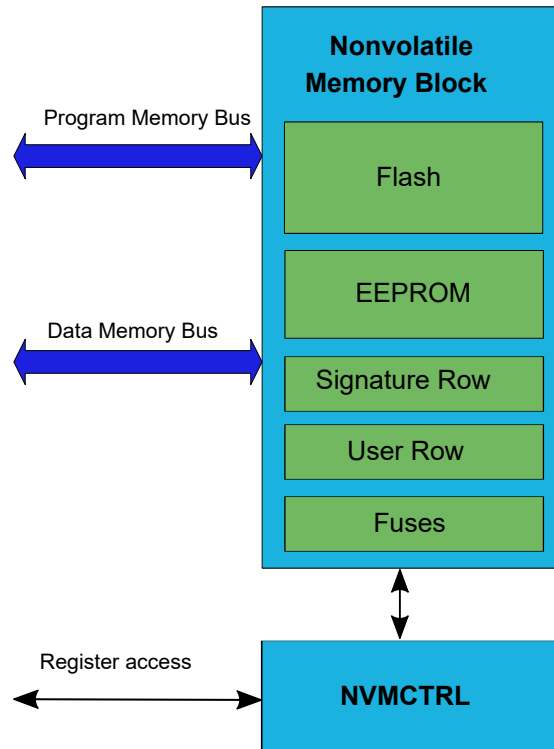
- In-System Programmable
- Self-Programming and Boot Loader Support
- Configurable Memory Sections:
  - Boot loader code section
  - Application code section
  - Application data section
- Signature Row for Factory-Programmed Data:
  - ID for each device type
  - Serial number for each device
  - Calibration bytes for factory-calibrated peripherals
- User Row for Application Data:
  - Can be read and written from software
  - Can be written from the UPDI on a locked device
  - Content is kept after chip erase

### **10.2 Overview**

The NVM Controller (NVMCTRL) is the interface between the CPU and Nonvolatile Memories (Flash, EEPROM, Signature Row, User Row and fuses). These are reprogrammable memory blocks that retain their values even when they are not powered. The Flash is mainly used for program storage and can also be used for data storage. The EEPROM is used for data storage and can be programmed while the CPU is running the program from the Flash.

## 10.2.1 Block Diagram

Figure 10-1. NVMCTRL Block Diagram



## 10.3 Functional Description

### 10.3.1 Memory Organization

#### 10.3.1.1 Flash

The Flash is divided into a set of pages. A page is the smallest addressable unit when erasing the Flash. It is only possible to erase an entire page or multiple pages at a time. Writes can be done per byte or word. One page consists of 512 bytes.

The Flash can be divided into three sections, each consisting of a variable number of pages. These sections are:

#### Boot Loader Code (BOOT) Section

The Flash section with full write access. Boot loader software must be placed in this section if used.

#### Application Code (APPCODE) Section

The Flash section with limited write access. An executable application code is usually placed in this section.

#### Application Data (APPDATA) Section

The Flash section without write access. Parameters are usually placed in this section.

#### Inter-Section Write Protection

For security reasons, it is not possible to write to the section of Flash the code is currently executing from. Code writing to the APPCODE section needs to be executed from the BOOT section, and code writing to the APPDATA section needs to be executed from either the BOOT section or the APPCODE section.

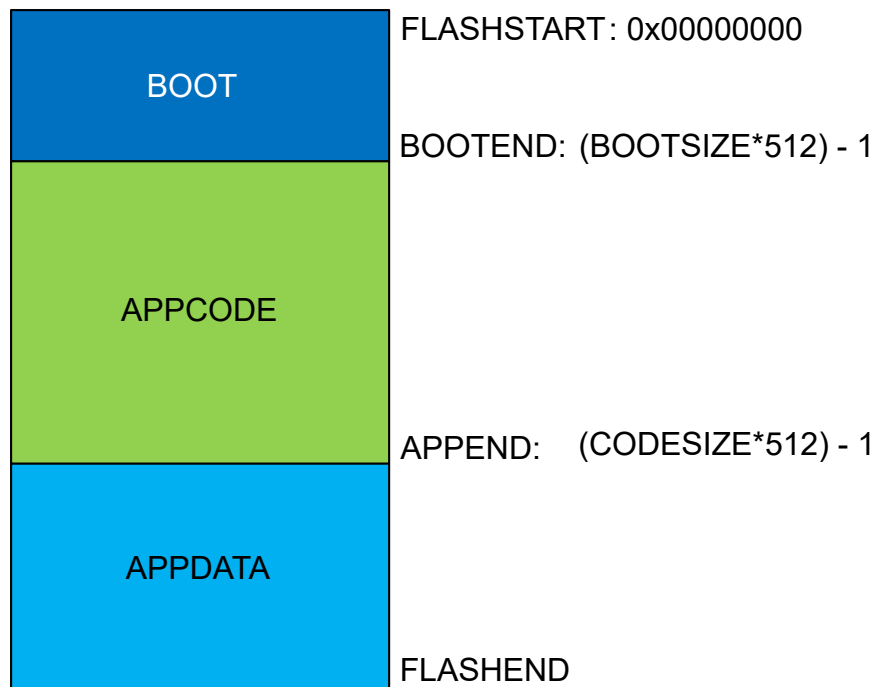
**Table 10-1. Write Protection for Self-Programming**

Program Execution Section	Section Being Addressed	Programming Allowed?	CPU Halted?
BOOT	BOOT	No	-
	APPCODE	Yes	Yes
	APPDATA		Yes
	EEPROM		No
APPCODE	BOOT	No	-
	APPCODE	Yes	Yes
	APPDATA		Yes
	EEPROM		No
APPDATA	BOOT	No	-
	APPCODE		-
	APPDATA		-
	EEPROM		-

**Section Sizes**

The sizes of these sections are set by the Boot Size (FUSE.BOOTSIZE) fuse and the Code Size (FUSE.CODESIZE) fuse. The fuses select the section sizes in blocks of 512 bytes. The BOOT section stretches from FLASHSTART to BOOTEND. The APPCODE section spreads from BOOTEND until APPEND. The remaining area is the APPDATA section.

**Figure 10-2. Flash Sections Sizes and Locations**



If FUSE.BOOTSIZE is written to '0', the entire Flash is regarded as the BOOT section. If FUSE.CODESIZE is written to '0' and FUSE.BOOTSIZE > 0, the APPCODE section runs from BOOTEND to the end of Flash (no APPDATA section).



When FUSE.CODESIZE ≤ FUSE.BOOTSIZE, the APPCODE section is removed, and the APPDATA runs from BOOTEND to the end of Flash.

**Table 10-2. Setting Up Flash Sections**

BOOTSIZE	CODESIZE	BOOT Section	APPCODE Section	APPDATA Section
0	-	0 to FLASHEND	-	-
> 0	0	0 to BOOTEND	BOOTEND to FLASHEND	-
> 0	≤ BOOTSIZE	0 to BOOTEND	-	BOOTEND to FLASHEND
> 0	> BOOTSIZE	0 to BOOTEND	BOOTEND to APPEND	APPEND to FLASHEND

If there is no boot loader software, it is recommended to use the BOOT section for application code.

**Notes:**

1. After Reset, the default vector table location is at the start of the APPCODE section. The peripheral interrupts can be used in the code running in the BOOT section by relocating the interrupt vector table at the start of this section. That is done by setting the IVSEL bit in the CPUINT.CTRLA register. Refer to the *CPUINT* section for details.
2. If BOOTEND/APPEND, as resulted from BOOTSIZE/CODESIZE fuse setting, exceed the device FLASHEND, the corresponding fuse setting is ignored, and the default value is used. Refer to “Fuse” in the *Memories* section for default values.

**Example 10-1. Size of Flash Sections Example**

If FUSE.BOOTSIZE is written to 0x04 and FUSE.CODESIZE is written to 0x08, the first 4\*512 bytes will be BOOT, the next 4\*512 bytes will be APPCODE, and the remaining Flash will be APPDATA.

**Flash Protection**

Additional to the inter-section write protection, the NVMCTRL provides a security mechanism to avoid unwanted access to the Flash memory sections. Even if the CPU can never write to the BOOT section, a Boot Section Read Protection (BOOTRP) bit in the Control B (NVMCTRL.CTRLB) register is provided to prevent the read and execution of code from the BOOT section. This bit can be set only from the code executed in the BOOT section and has effect only when leaving the BOOT section.

There are two other write protection (APPCODEWP and APPDATAWP) bits in the Control B (NVMCTRL.CTRLB) register that can be set to prevent further updates of the respective Application Code and Application Data sections.

**10.3.1.2 EEPROM**

The EEPROM is a 512 bytes nonvolatile memory section that has byte granularity on erase/write. It can be erased in blocks of 1/2/4/8/16/32 bytes, but writes are done only one byte at a time. It also has an option to do a byte erase and write in one operation.

**10.3.1.3 Signature Row**

The Signature Row contains a device ID that identifies each microcontroller device type and a serial number for each manufactured device. The serial number consists of the production lot number, wafer number, and wafer coordinates for the device. The Signature Row cannot be written or erased, but it can be read by the CPU or through the UPDI interface.

**10.3.1.4 User Row**

The User Row is 32 bytes. This section can be used to store various data, such as calibration/configuration data and serial numbers. This section is not erased by a chip erase.

The User Row section can be read or written from the CPU. This section can be read from UPDI on a device unlocked and can be written through UPDI even on a device locked.

**10.3.1.5 Fuses**

The fuses contain device configuration values and are copied to their respective target registers at the end of the start-up sequence.

The fuses can be read by the CPU or the UPDI, but can only be programmed or cleared by the UPDI.

**10.3.2 Memory Access**

For read/write operations, the Flash memory can be accessed either from the code space or from the CPU data space. When the code space is used, the Flash is accessible through the `LPM` and `SPM` instructions.

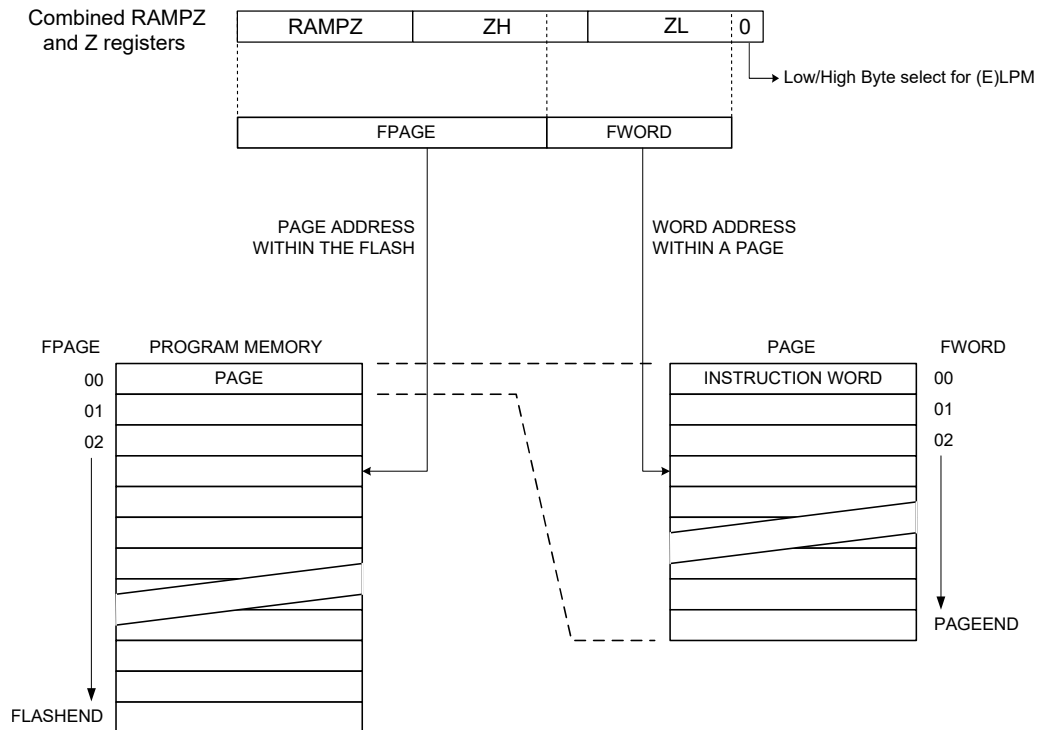
Additionally, the Flash memory is byte accessible when accessed through the CPU data space. This means that it shares the same address space and instructions as SRAM, EEPROM, and I/O registers and is accessible using `LD/ST` instructions in assembly.

For the `LPM` and `SPM` instructions, address 0x0000 is the start of the Flash, but for `LD` and `ST`, it is 0x8000, as shown in the *Memory map* section.

**Addressing Flash Memory in Code Space**

For read and write access to the Flash memory in the code space, the RAMPZ register concatenated with the Z register to create the Address Pointer that is used for `LPM/SPM` access.

**Figure 10-3. Flash Addressing for Self-Programming**



The Flash is word-accessed and organized in pages, so the Address Pointer can be treated as having two sections. This is shown in Figure 10-3. The word address in the page (FWORD) is held by the Least Significant bits in the Address Pointer, while the most significant bits in the Address Pointer hold the Flash page address (FPAGE). Together, FWORD and FPAGE hold an absolute address to a word in the Flash.

The Flash is word-accessed for code space write operations, so the Least Significant bit (bit 0) in the Address Pointer is ignored.

For Flash read operations, one byte is read at a time. For this, the Least Significant bit (bit 0) in the Address Pointer is used to select the low byte or high byte in the word address. If this bit is '0', the low byte is read, and if this bit is '1', the high byte is read.

Once a programming operation is initiated, the address is latched, and the Address Pointer can be updated and used for other operations.

### Addressing Flash in CPU Data Space

The Flash area in data space has only 32 KB. For devices with Flash memory size greater than 32 KB, the Flash memory is divided into blocks of 32 KB. Those blocks are mapped into data space using the FLMAP bit field of the NVMCTRL.CTRLB register.

For read and write access to the Flash memory in the CPU data space, the LD/ST instructions are used to access one byte at a time.

#### 10.3.2.1 Read

Reading the Flash is done using Load Program Memory (LPM) instructions or load type (LD\*) instructions with an address according to the memory map. Reading the EEPROM and Signature Row is done using load type instructions (LD\*). Performing a read operation while a write or erase is in progress will result in a bus wait, and the instruction will be suspended until the ongoing operation is complete.

#### 10.3.2.2 Programming

The Flash programming is done by writing one byte or one word at a time. Writing from the CPU using store type instructions (ST\*) will write one byte at a time, while a write with the Store Program Memory (SPM) instruction will write one word at a time.

The NVMCTRL command set supports multiple Flash erase operations. Up to 32 pages can be erased at the same time. The duration of the erase operation is independent of the number of pages being erased.

The EEPROM erasing has byte granularity with the possibility of erasing up to 32 bytes in one operation. The EEPROM is written one byte at a time, and it has an option to do the erase and write of one byte in the same operation.

The User Row is erased/written as a normal Flash. When the erasing operation is used, the entire User Row is erased at once. The User Row writing has byte granularity.

The Fuse programming is identical to the EEPROM programming, but it can be performed only via the UPDI interface.

**Table 10-3. Programming Granularity**

Memory Section	Erase Granularity	Write Granularity
Flash array	Page	Word <sup>(1)</sup>
EEPROM array	Byte	Byte
User Row	Page <sup>(2)</sup>	Byte <sup>(3)</sup>
Fuses	Byte	Byte

**Notes:**

1. Byte granularity when writing to the CPU data space memory mapped section.
2. One page is 32 bytes.
3. Page granularity when programming from UPDI on a locked device.

#### 10.3.2.3 Command Modes

Reading of the memory arrays is handled using the LD\*/LPM<sup>(1)</sup> instructions.

The erase of the whole Flash (CHER) or the EEPROM (EECHER) is started by writing commands to the NVMCTRL.CTRLA register. The other write/erase operations are just enabled by writing commands to the NVMCTRL.CTRLA register and must be followed by writes using ST\*/SPM<sup>(1)</sup> instructions to the memory arrays.

**Note:**

1. LPM/SPM cannot be used for EEPROM.

To write a command in the NVMCTRL.CTRLA register, the following sequence needs to be executed:

1. Confirm that any previous operation is completed by reading the Busy (EEBUSY and FBUSY) flags in the NVMCTRL.STATUS register.

2. Write the appropriate key to the Configuration Change Protection (CPU.CCP) register to unlock the NVM Control A (NVMCTRL.CTRLA) register.
3. Write the desired command value to the CMD bit field in the Control A (NVMCTRL.CTRLA) register within the next four instructions.

To perform a write/erase operation in the NVM, the following steps are required:

1. Confirm that any previous operation is completed by reading the Busy (EEBUSY and FBUSY) flags in the NVMCTRL.STATUS register.
2. Optional: If the Flash is accessed in the CPU data space, map the corresponding 32 KB Flash section into the data space by writing the FLMAP bit field in the NVMCTRL.CTRLB register.
3. Write the desired command value to the NVMCTRL.CTRLA register as described before.
4. Write to the correct address in the data space/code space using the `ST*`/`SPM` instructions.
5. Optional: If multiple write operations are required, go to step 4.
6. Write a `NOOP` or `NOCMD` command to the NVMCTRL.CTRLA register to clear the current command.

### 10.3.2.3.1 Flash Write Mode

The Flash Write (FLWR) mode of the Flash controller enables writes to the Flash array to start a programming operation. Several writes can be done while the FLWR mode is enabled in the NVMCTRL.CTRLA register. When the FLWR mode is enabled, the `ST*` instructions write one byte at a time, while the `SPM` instruction writes one word at a time.

Before a write is performed to an address, its content needs to be erased.

### 10.3.2.3.2 Flash Page Erase Mode

The Flash Page Erase (FLPER) mode will allow each write to the memory array to erase a page.

An erase operation to the Flash will halt the CPU.

### 10.3.2.3.3 Flash Multi-Page Erase Mode

The Multi-Page Erase (FLMPERn) mode will allow each write to the memory array to erase multiple pages. When enabling FLMPERn, it is possible to select between erasing two, four, eight, 16, or 32 pages.

The LSBs of the page address are ignored when defining which Flash pages are erased. Using FLMPER4 as an example, erasing any page in the `0x08 - 0x0B` range will cause the erase of all pages in the range.

**Table 10-4. Flash Multi-Page Erase**

CMD	Pages Erased	Description
FLMPER2	2	Pages matching <code>FPAGE[N:1]</code> are erased. The value in <code>FPAGE[0]</code> is ignored.
FLMPER4	4	Pages matching <code>FPAGE[N:2]</code> are erased. The value in <code>FPAGE[1:0]</code> is ignored.
FLMPER8	8	Pages matching <code>FPAGE[N:3]</code> are erased. The value in <code>FPAGE[2:0]</code> is ignored.
FLMPER16	16	Pages matching <code>FPAGE[N:4]</code> are erased. The value in <code>FPAGE[3:0]</code> is ignored.
FLMPER32	32	Pages matching <code>FPAGE[N:5]</code> are erased. The value in <code>FPAGE[4:0]</code> is ignored.

**Note:** `FPAGE` is the page number when doing a Flash erase. Refer to [Figure 10-3](#) for details.

### 10.3.2.3.4 EEPROM Write Mode

The EEPROM Write (EEWR) mode enables the EEPROM array for writing operations. Several writes can be done while the EEWR mode is enabled in the NVMCTRL.CTRLA register. When the EEWR mode is enabled, writes with the `ST*` instructions will be performed one byte at a time.

When writing the EEPROM, the CPU will continue executing code. If a new load/store operation is started before the EEPROM erase/write is completed, the CPU will be halted.

Before a write is performed to an address, its content needs to be erased.

### 10.3.2.3.5 EEPROM Erase/Write Mode

The EEPROM Erase/Write (EEERWR) mode enables the EEPROM array for the erase operation directly followed by a write operation. Several erase/writes can be done while the EEERWR mode is enabled in the NVMCTRL.CTRLA register. When the EEERWR mode is enabled, writes with the `ST*` instructions are performed one byte at a time.

When writing/erasing the EEPROM, the CPU will continue executing code.

If a new load or store instruction is started before the erase/write is completed, the CPU will be halted.

### 10.3.2.3.6 EEPROM Byte Erase Mode

The EEPROM Byte Erase (EEBER) mode will allow each write to the memory array to erase the selected byte. An erased byte always reads back `0xFF`, regardless of the value written to the EEPROM address.

When erasing the EEPROM, the CPU can continue to run from the Flash. If the CPU starts an erase or write operation while the EEPROM is busy, the CPU will be halted until the previous operation is finished.

### 10.3.2.3.7 EEPROM Multi-Byte Erase Mode

The EEPROM Multi-Byte Erase (EEMBERn) mode allows erasing several bytes in one operation. When enabling the EEMBERn mode, it is possible to select between erasing two, four, eight, 16, or 32 bytes in one operation.

The LSBs of the address are ignored when defining which EEPROM locations are erased. For example, while doing an 8-byte erase, addressing any byte in the `0x18 - 0x1F` range will result in erasing the entire range of bytes.

**Table 10-5. EEPROM Multi-Byte Erase**

CMD	Bytes Erased	Description <sup>(1)</sup>
EEMBER2	2	Addresses matching ADDR[N:1] are erased. The value in ADDR[0] is ignored.
EEMBER4	4	Addresses matching ADDR[N:2] are erased. The value in ADDR[1:0] is ignored.
EEMBER8	8	Addresses matching ADDR[N:3] are erased. The value in ADDR[2:0] is ignored.
EEMBER16	16	Addresses matching ADDR[N:4] are erased. The value in ADDR[3:0] is ignored.
EEMBER32	32	Addresses matching ADDR[N:5] are erased. The value in ADDR[4:0] is ignored.

**Note:** ADDR is the address written when doing an EEPROM erase.

When erasing the EEPROM, the CPU can continue to execute instructions from the Flash. If the CPU starts an erase or write operation while the EEPROM is busy, the NVMCTRL module will give a wait on the bus, and the CPU will be halted until the current operation is finished.

### 10.3.2.3.8 Chip Erase Command

The Chip Erase (`CHER`) command erases the Flash and the EEPROM. The EEPROM is unaltered if the EEPROM Save During Chip Erase (EESAVE) fuse in FUSE.SYSCFG0 is set.

If the device is locked, the EEPROM is always erased by a chip erase regardless of the EESAVE bit. The read/write protection (BOOTRP, APPCODEWP, APPDATAWP) bits in NVMCTRL.CTRLB do not prevent the operation. All Flash and EEPROM bytes will read back `0xFF` after this command.

This command can only be started from the UPDI.

### 10.3.2.3.9 EEPROM Erase Command

The EEPROM Erase (`EECHER`) command erases the EEPROM. All EEPROM bytes will read back `0xFF` after the operation. The CPU will be halted while the EEPROM is being erased.

## 10.3.3 Preventing Flash/EEPROM Corruption

A Flash/EEPROM write or erase can cause memory corruption if the supply voltage is too low for the CPU and the Flash/EEPROM to operate properly. These issues are the same on-board level systems using Flash/EEPROM, and it is recommended to use the internal or an external Brown-out Detector (BOD) to ensure that the device is not operating at too low voltage.

When the voltage is too low, a Flash/EEPROM corruption may be caused by two circumstances:

1. A regular write sequence to the Flash, which requires a minimum voltage to operate correctly.

2. The CPU itself can execute instructions incorrectly when the supply voltage is too low.

The chip erase does not clear fuses. If the BOD is enabled before starting the Chip Erase command, it is automatically enabled at its previous configured level during the chip erase.

Refer to the *Electrical Characteristics* section for Maximum Frequency vs.  $V_{DD}$ .



**Attention:** Flash/EEPROM corruption can be avoided by taking the following measures:

1. Keep the device in Reset during periods of insufficient power supply voltage. This can be done by enabling the internal BOD.
2. The Voltage Level Monitor (VLM) in the BOD can be used to prevent starting a write to the EEPROM close to the BOD level.
3. If the detection levels of the internal BOD do not match the required detection level, an external low  $V_{DD}$  Reset protection circuit can be used. If a Reset occurs while a write operation is ongoing, the write operation will be aborted.

### 10.3.4 Interrupts

**Table 10-6. Available Interrupt Vectors and Sources**

Offset	Name	Vector Description	Conditions
0x00	EEREADY	NVM	The EEPROM is ready for new write/erase operations.

When an interrupt condition occurs, the corresponding interrupt flag is set in the Interrupt Flags (NVMCTRL.INTFLAGS) register.

An interrupt source is enabled or disabled by writing to the corresponding bit in the Interrupt Control (NVMCTRL.INTCTRL) register.

An interrupt request is generated when the corresponding interrupt source is enabled, and the interrupt flag is set. The interrupt request remains active until the interrupt flag is cleared. See the NVMCTRL.INTFLAGS register for details on how to clear interrupt flags.

### 10.3.5 Sleep Mode Operation

If there is no ongoing EEPROM write/erase operation, the NVMCTRL will enter sleep mode, when the system enters sleep mode.

If an EEPROM write/erase operation is ongoing when the system enters a sleep mode, the NVM block, the NVMCTRL and the peripheral clock will remain ON until the operation is finished and will be automatically turned off once the operation is completed. This is valid for all sleep modes, including Power-Down.

The EEPROM Ready interrupt will wake up the device only from Idle sleep mode.

### 10.3.6 Configuration Change Protection

This peripheral has registers that are under Configuration Change Protection (CCP). To write to these registers, a certain key must first be written to the CPU.CCP register, followed by a write access to the protected bits within four CPU instructions.

Attempting to write to a protected register without following the appropriate CCP unlock sequence leaves the protected register unchanged.

The following registers are under CCP:

**Table 10-7. NVMCTRL - Registers under Configuration Change Protection**

Register	Key
NVMCTRL.CTRLA	SPM
NVMCTRL.CTRLB	IOREG

## 10.4 Register Summary

Offset	Name	Bit Pos.	7	6	5	4	3	2	1	0
0x00	<a href="#">CTRLA</a>	7:0					CMD[6:0]			
0x01	<a href="#">CTRLB</a>	7:0	FLMAPLOCK		FLMAP[1:0]			APPDATAWP	BOOTRP	APPCODEWEP
0x02	<a href="#">STATUS</a>	7:0			ERROR[2:0]				EEBUSY	FBUSY
0x03	<a href="#">INTCTRL</a>	7:0								EEREADY
0x04	<a href="#">INTFLAGS</a>	7:0								EEREADY
0x05	Reserved									
0x06	<a href="#">DATA</a>	7:0	DATA[7:0]							
		15:8	DATA[15:8]							
0x08	<a href="#">ADDR</a>	7:0	ADDR[7:0]							
		15:8	ADDR[15:8]							
		23:16	ADDR[23:16]							

## 10.5 Register Description

### 10.5.1 Control A

**Name:** CTRLA  
**Offset:** 0x00  
**Reset:** 0x00  
**Property:** Configuration Change Protection

	7	6	5	4	3	2	1	0
	CMD[6:0]							
Access		R/W	R/W	R/W	R/W	R/W	R/W	R/W
Reset		0	0	0	0	0	0	0

#### Bits 6:0 – CMD[6:0] Command

Write this bit field to enable or issue a command. The Chip Erase and EEPROM Erase commands are started when the command is written. The others enable an erase or write operation. The operation is started by doing a store instruction to an address location.

A change from one command to another must always go through No command (NOCMD) or No operation (NOOP) command to avoid the Command Collision error being set in the ERROR bit field from the NVMCTRL.STATUS register.

Value	Name	Description
0x00	NOCMD	No command
0x01	NOOP	No operation
0x02	FLWR	Flash Write Enable
0x08	FLPER	Flash Page Erase Enable
0x09	FLMPER2	Flash 2-page Erase Enable
0x0A	FLMPER4	Flash 4-page Erase Enable
0x0B	FLMPER8	Flash 8-page Erase Enable
0x0C	FLMPER16	Flash 16-page Erase Enable
0x0D	FLMPER32	Flash 32-page Erase Enable
0x12	EEWR	EEPROM Write Enable
0x13	EEERWR	EEPROM Erase and Write Enable
0x18	EEBER	EEPROM Byte Erase Enable
0x19	EEMBER2	EEPROM 2-byte Erase Enable
0x1A	EEMBER4	EEPROM 4-byte Erase Enable
0x1B	EEMBER8	EEPROM 8-byte Erase Enable
0x1C	EEMBER16	EEPROM 16-byte Erase Enable
0x1D	EEMBER32	EEPROM 32-byte Erase Enable
0x20	CHER	Erase Flash and EEPROM. EEPROM is skipped if EESAVE fuse is set. (UPDI access only.)
0x30	EECHER	Erase EEPROM
Other	-	Reserved



### 10.5.2 Control B

**Name:** CTRLB  
**Offset:** 0x01  
**Reset:** 0x30  
**Property:** Configuration Change Protection

	Bit	7	6	5	4	3	2	1	0
		FLMAPLOCK		FLMAP[1:0]			APPDATAWP	BOOTRP	APPCODEWP
Access		R/W		R/W	R/W		R/W	R/W	R/W
Reset		0		1	1		0	0	0

**Bit 7 – FLMAPLOCK** Flash Mapping Lock  
 Setting this bit to '1' prevents further updates of FLMAP[1:0]. This bit can only be cleared by a Reset.

**Bits 5:4 – FLMAP[1:0]** Flash Section Mapped into Data Space  
 Select what part (in blocks of 32 KB) of the Flash will be mapped as part of the CPU data space and will be accessible through LD/ST instructions.  
 This bit field is not under Configuration Change Protection.

Value	Name	Mapped Flash Section [KB]		
		32 KB Flash	64 KB Flash	128 KB Flash
0	SECTION0	0-32	0-32	0-32
1	SECTION1		32-64	32-64
2	SECTION2		0-32	64-96
3	SECTION3		32-64	96-12

**Bit 2 – APPDATAWP** Application Data Section Write Protection  
 Writing this bit to '1' prevents further updates to the Application Data section. This bit can only be cleared by a Reset.

**Bit 1 – BOOTRP** Boot Section Read Protection  
 Writing this bit to '1' will protect the BOOT section from reading and instruction fetching. If a read is issued from the other Flash sections, it will return '0'. An instruction fetch from the BOOT section will return a NOP instruction. This bit can only be written from the BOOT section, and it can only be cleared by a Reset. The read protection will only take effect when leaving the BOOT section after the bit is written.

**Bit 0 – APPCODEWP** Application Code Section Write Protection  
 Writing this bit to '1' prevents further updates to the Application Code section. This bit can only be cleared by a Reset.

### 10.5.3 Status

**Name:** STATUS  
**Offset:** 0x02  
**Reset:** 0x00  
**Property:** -

	7	6	5	4	3	2	1	0
	ERROR[2:0]						EEBUSY	FBUSY
Access		R/W	R/W	R/W			R	R
Reset		0	0	0			0	0

**Bits 6:4 – ERROR[2:0] Error Code**

The Error Code bit field will show the last error occurring. This bit field can be cleared by writing it to '0'.

Value	Name	Description
0x0	NONE	No error
0x1	INVALIDCMD	The selected command is not supported
0x2	WRITEPROTECT	Attempt to write a section that is protected
0x3	CMDCOLLISION	A new write/erase command was selected while a write/erase command is already ongoing
Other	—	Reserved

**Bit 1 – EEBUSY EEPROM Busy**

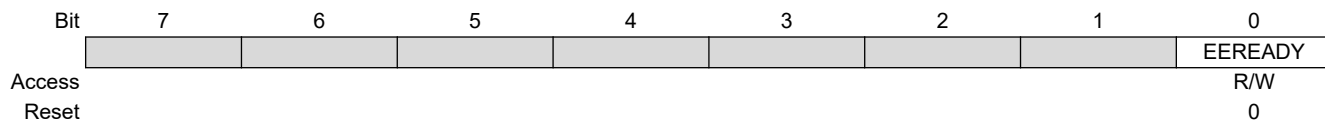
This bit will read '1' when an EEPROM programming operation is ongoing.

**Bit 0 – FBUSY Flash Busy**

This bit will read '1' when a Flash programming operation is ongoing.

#### 10.5.4 Interrupt Control

**Name:** INTCTRL  
**Offset:** 0x03  
**Reset:** 0x00  
**Property:** -



**Bit 0 – EEREADY** EEPROM Ready Interrupt

Writing a '1' to this bit enables the interrupt which indicates that the EEPROM is ready for new write/erase operations.

This is a level interrupt that will be triggered only when the EEREADY bit in the INTFLAGS register is set to '1'. The interrupt must not be enabled before triggering an EEPROM write/erase operation, as the EEREADY bit will not be cleared before this command is issued. The interrupt must be disabled in the interrupt handler.

### 10.5.5 Interrupt Flags

**Name:** INTFLAGS  
**Offset:** 0x04  
**Reset:** 0x00  
**Property:** -

Bit	7	6	5	4	3	2	1	0
Access								EEREADY
Reset								0

**Bit 0 – EEREADY** EEREADY Interrupt Flag

This flag is set continuously as long as the EEPROM is not busy. This flag is cleared by writing a '1' to it.

### 10.5.6 Data

**Name:** DATA  
**Offset:** 0x06  
**Reset:** 0x00  
**Property:** -

The NVMCTRL.DATAL and NVMCTRL.DATAH register pair represents the 16-bit value, NVMCTRL.DATA.

The low byte [7:0] (suffix L) is accessible at the original offset.

The high byte [15:8] (suffix H) can be accessed at offset + 0x01.

	Bit	15	14	13	12	11	10	9	8
		DATA[15:8]							
Access		R/W	R/W	R/W	R/W	R/W	R/W	R/W	R/W
Reset		0	0	0	0	0	0	0	0
	Bit	7	6	5	4	3	2	1	0
		DATA[7:0]							
Access		R/W	R/W	R/W	R/W	R/W	R/W	R/W	R/W
Reset		0	0	0	0	0	0	0	0

#### Bits 15:0 – DATA[15:0] Data Register

The Data register will contain the last read value from Flash, EEPROM, or NVMCTRL. For EEPROM access, only DATA[7:0] is used.

# AVR128DA28/32/48/64

## NVMCTRL - Nonvolatile Memory Controller

### 10.5.7 Address

**Name:** ADDR  
**Offset:** 0x08  
**Reset:** 0x00  
**Property:** -

NVMCTRL.ADDR0, NVMCTRL.ADDR1 and NVMCTRL.ADDR2 represent the 24-bit value NVMCTRL.ADDR.

The low byte [7:0] (suffix 0) is accessible at the original offset.

The high byte [15:8] (suffix 1) can be accessed at offset +0x01.

The extended byte [23:16] (suffix 2) can be accessed at offset +0x02.

	Bit	23	22	21	20	19	18	17	16
		ADDR[23:16]							
Access		R/W	R/W	R/W	R/W	R/W	R/W	R/W	R/W
Reset		0	0	0	0	0	0	0	0
	Bit	15	14	13	12	11	10	9	8
		ADDR[15:8]							
Access		R/W	R/W	R/W	R/W	R/W	R/W	R/W	R/W
Reset		0	0	0	0	0	0	0	0
	Bit	7	6	5	4	3	2	1	0
		ADDR[7:0]							
Access		R/W	R/W	R/W	R/W	R/W	R/W	R/W	R/W
Reset		0	0	0	0	0	0	0	0

**Bits 23:0 – ADDR[23:0] Address**

The Address register contains the address of the last memory location that has been accessed. Only the number of bits required to access the memory is used.

## **11. CLKCTRL - Clock Controller**

### **11.1 Features**

- All Clocks and Clock Sources are Automatically Enabled when Requested by Peripherals
- Internal Oscillators:
  - Internal High-Frequency Oscillator (OSCHF): up to 24 MHz
  - 32.768 kHz Ultra Low-Power Oscillator (OSC32K)
  - Up to 48 MHz PLL; clock multiplication by 2x or 3x
- Auto-Tuning for Improved Internal Oscillator Accuracy
- External Clock Options:
  - 32.768 kHz Crystal Oscillator (XOSC32K)
  - External clock
- Main Clock Features:
  - Safe run-time switching
  - Prescaler with a division factor ranging from 1 to 64

### **11.2 Overview**

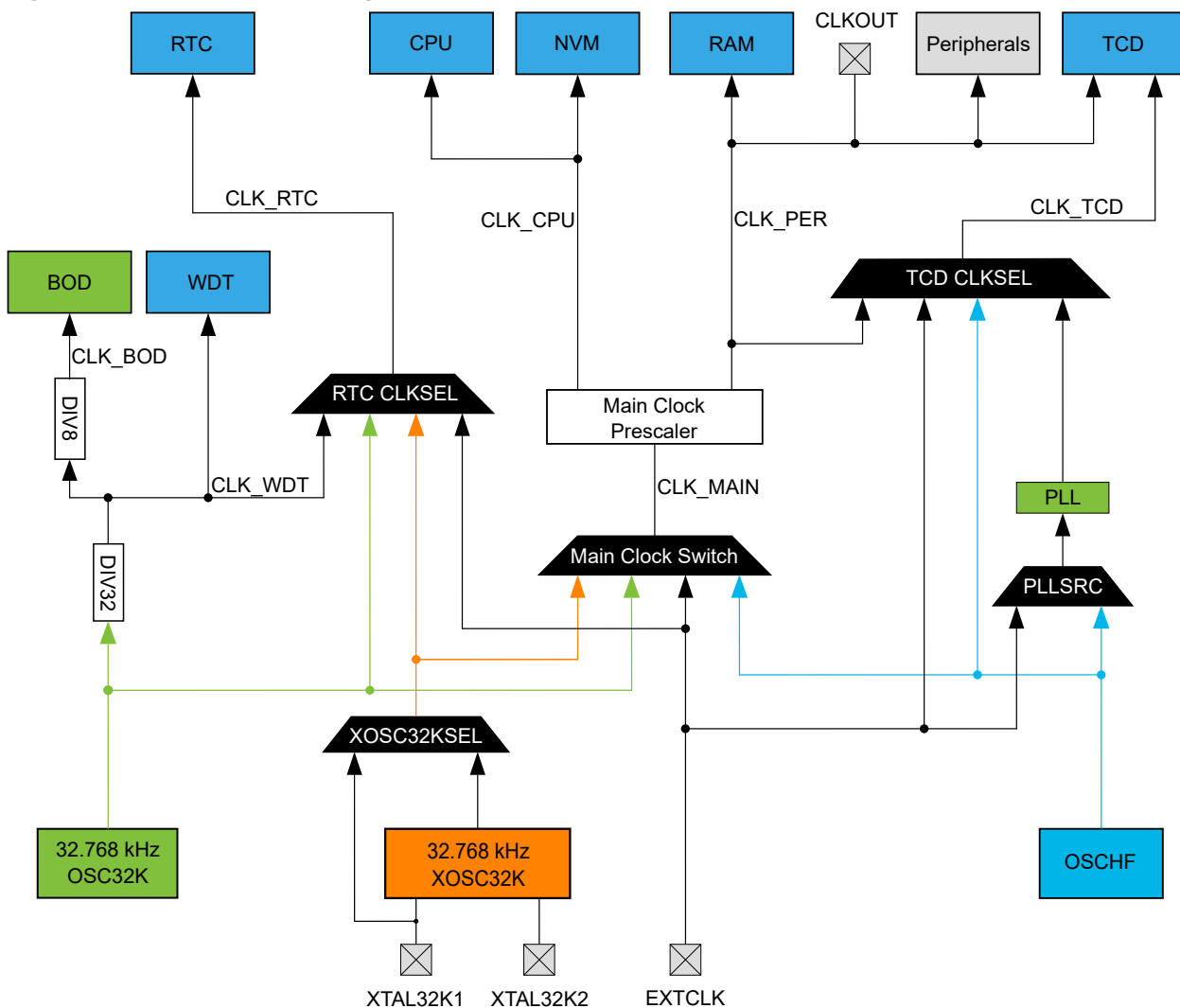
The Clock Controller (CLKCTRL) controls, distributes and prescales the clock signals from the available oscillators. The CLKCTRL supports internal and external clock sources.

The CLKCTRL is based on an automatic clock request system, implemented in all peripherals on the device. The peripherals will automatically request the clocks needed. The request is routed to the correct clock source if multiple clock sources are available.

The Main Clock (CLK\_MAIN) is used by the CPU, RAM and all peripherals connected to the I/O bus. The main clock source can be selected and prescaled. Some peripherals can share the same clock source as the main clock, or run asynchronously to the main clock domain.

11.2.1 Block Diagram - CLKCTRL

Figure 11-1. CLKCTRL Block Diagram



The clock system consists of the main clock and clocks derived from the main clock, as well as several asynchronous clocks:

- Main Clock  
CLK\_MAIN is always running in Active and Idle sleep modes, and in Standby sleep mode if requested.  
CLK\_MAIN is prescaled and distributed by the clock controller:
  - CLK\_CPU is used by the CPU and the NVMCTRL
  - CLK\_PER is used by SRAM and all peripherals that are not listed under asynchronous clocks and can also be routed to the CLKOUT pin
  - All the clock sources can be used as main clock
- Clocks running asynchronously to the main clock domain:
  - CLK\_RTC is used by the Real-Time Counter (RTC) and the Periodic Interrupt Timer (PIT). It will be requested when the RTC/PIT is enabled. The clock source for CLK\_RTC may be changed only if the peripheral is disabled.
  - CLK\_WDT is used by the Watchdog Timer (WDT). It will be requested when the WDT is enabled.
  - CLK\_BOD is used by the Brown-out Detector (BOD). It will be requested when the BOD is enabled in the Sampled mode. The alternative clock source is controlled by a fuse.
  - CLK\_TCD is used by the Timer Counter type D (TCD). It will be requested when the TCD is enabled. The clock source may be changed only if the peripheral is disabled.



The clock source for the main clock domain is configured by writing to the Clock Select (CLKSEL) bit field in the Main Clock Control A (CLKCTRL.MCLKCTRLA) register. This register has Configuration Change Protection (CCP), and the appropriate key must be written to the CCP register before writing to the CLKSEL bit field. The asynchronous clock sources are configured by the registers in the respective peripheral.

### 11.2.2 Signal Description

Signal	Type	Description
CLKOUT	Digital output	CLK_PER output

For more details, refer to the *I/O Multiplexing* section.

## 11.3 Functional Description

### 11.3.1 Main Clock Selection and Prescaler

All internal oscillators and the EXTCLK can be used as the main clock source for CLK\_MAIN. The main clock source is selectable from software and can be safely changed during normal operation.

The Configuration Change Protection mechanism prevents unsafe clock switching.

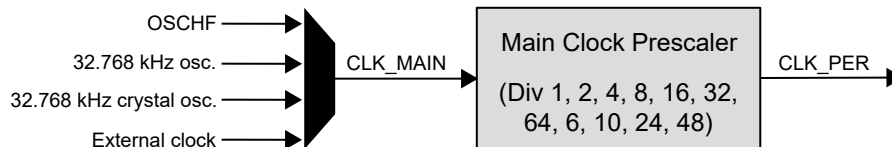
Upon the selection of an external clock source, a switch to the chosen clock source will occur only if edges are detected, indicating it is stable. Until a sufficient number of clock edges are detected, the switch will not occur, and it will not be possible to change to another clock source again without executing a Reset.

An ongoing clock source switch is indicated by the Main Clock Oscillator Changing (SOSC) bit in the Main Clock Status (CLKCTRL.MCLKSTATUS) register. The stability of the external clock sources is indicated by the respective Status (EXTS and XOSC32KS) bits in CLKCTRL.MCLKSTATUS.

**CAUTION** If an external clock source fails while used as the CLK\_MAIN source, only the WDT can provide a System Reset.

The CLK\_MAIN is fed into the prescaler before being used by the peripherals (CLK\_PER) in the device. The prescaler divides CLK\_MAIN by a factor from 1 to 64.

**Figure 11-2. Main Clock and Prescaler**



For more details, refer to the *Configuration Change Protection* section.

### 11.3.2 Main Clock After Reset

After any Reset, the Main Clock (CLK\_MAIN) is provided either by the OSCHF, running at the default frequency of 4 MHz, or the OSC32K, depending on the Clock Select (CLKSEL) bit field configuration of the Oscillator Configuration (FUSE.OSCCFG) fuse. Refer to the description of the FUSE.OSCCFG fuse for details of the possible frequencies after Reset.

### 11.3.3 Clock Sources

The clock sources are divided into two main groups: internal oscillators and external clock sources. All the internal clock sources are automatically enabled when they are requested by a peripheral.

The crystal oscillator must be enabled by writing a '1' to the ENABLE bit in the 32.768 kHz Crystal Oscillator Control A (CLKCTRL.XOSC32KCTRLA) register before it can serve as a clock source.

After Reset, the device starts running from the internal high-frequency oscillator or the internal 32.768 kHz oscillator.

The respective Oscillator Status bits in the Main Clock Status (CLKCTRL.MCLKSTATUS) register indicate if the clock source is running and stable.

### 11.3.3.1 Internal Oscillators

The internal oscillators do not require any external components to run. Refer to the *Electrical Characteristics* section for accuracy and electrical specifications.

#### 11.3.3.1.1 Internal High-Frequency Oscillator (OSCHF)

The OSCHF supports output frequencies of 1, 2, 3, 4 MHz, and multiples of 4, up to 24 MHz, which can be used as main clock, peripheral clock, or as input to PLL.

#### 11.3.3.1.2 32.768 kHz Oscillator (OSC32K)

The 32.768 kHz oscillator is optimized for Ultra Low-Power (ULP) operation. Power consumption is decreased at the cost of decreased accuracy compared to an external crystal oscillator.

This oscillator provides a 1.024 kHz or 32.768 kHz clock for the Real-Time Counter (RTC), the Watchdog Timer (WDT) and the Brown-out Detector (BOD). Additionally, this oscillator can also provide a 32.768 kHz clock to the CLK\_MAIN.

For the start-up time of this oscillator, refer to the *Electrical Characteristics* section.

### 11.3.3.2 External Clock Sources

These external clock sources are available:

- External Clock from a pin (EXTCLK)
- The XTAL32K1 and XTAL32K2 pins are dedicated to driving a 32.768 kHz crystal oscillator (XOSC32K)
- Instead of a crystal oscillator, XTAL32K1 can be configured to accept an external clock source

#### 11.3.3.2.1 32.768 kHz Crystal Oscillator (XOSC32K)

This oscillator supports two input options:

- A crystal is connected to the XTAL32K1 and XTAL32K2 pins
- An external clock running at 32.768 kHz, connected to XTAL32K1

The input option must be configured by writing the Source Select (SEL) bit in the XOSC32K Control A (CLKCTRL.XOSC32KCTRLA) register.

The XOSC32K is enabled by writing a '1' to its ENABLE bit in CLKCTRL.XOSC32KCTRLA. When enabled, the configuration of the GPIO pins used by the XOSC32K is overridden as XTAL32K1 and XTAL32K2 pins. The ENABLE bit needs to be set for the oscillator to start running when requested.

The start-up time of a given crystal oscillator can be accommodated by writing to the Crystal Start-up Time (CSUT) bit field in XOSC32K Control A (CLKCTRL.XOSC32KCTRLA) register.

When XOSC32K is configured to use an external clock on XTAL32K1, the start-up time is fixed to two cycles.

#### 11.3.3.2.2 External Clock (EXTCLK)

The EXTCLK is taken directly from the pin. This GPIO pin is automatically configured for the EXTCLK if any peripheral requests this clock.

The maximum input frequency for the EXTCLK is 24 MHz.

This clock source has a start-up time of two cycles when first requested.

### 11.3.4 Phase-Locked Loop (PLL)

The PLL provides clock multiplication by 2x or 3x, and it can be used only when the reference clock (EXTCLK or OSCHF) is at least 16 MHz. The PLL can run in Active, Idle and Standby modes, and can serve as input clock for TCD.

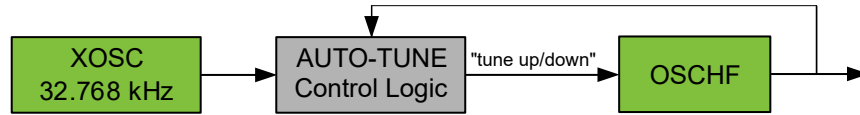
The maximum frequency generated using the PLL is 48 MHz.

### 11.3.5 Auto-Tune

The auto-tune feature can be used to improve the accuracy of the internal oscillator. The internal 1 MHz clock is compared to a 1.024 kHz reference from the crystal. If an error is detected, the frequency calibration will be adjusted according to the error.

The check against the reference clock runs for as long as an error is detected. When the oscillator is tuned in, and no error is detected, the auto-tune feature will disable itself for 64 ms before it starts a new check.

**Figure 11-3. OSCHF Auto-Tune Block Diagram**



### 11.3.6 Sleep Mode Operation

When a clock source is not used or requested, it will stop. It is possible to request a clock source directly by writing a '1' to the Run Standby (RUNSTDBY) bit in the respective oscillator's Control A (CLKCTRL.[osc]CTRLA) register. This will cause the oscillator to run constantly, except for Power-Down sleep mode. Additionally, when this bit is written to '1', the oscillator start-up time is eliminated when the clock source is requested by a peripheral.

The main clock will always run in Active and Idle sleep modes. In Standby sleep mode, the main clock will run only if any peripheral is requesting it, or the Run in Standby (RUNSTDBY) bit in the respective oscillator's Control A (CLKCTRL.[osc]CTRLA) register is written to '1'.

In Power-Down sleep mode, the main clock will stop after all NVM operations are completed. Refer to the *Sleep Controller* section for more details on sleep mode operation.

### 11.3.7 Configuration Change Protection

This peripheral has registers that are under Configuration Change Protection (CCP). To write to these registers, a certain key must first be written to the CPU.CCP register, followed by a write access to the protected bits within four CPU instructions.

Attempting to write to a protected register without following the appropriate CCP unlock sequence leaves the protected register unchanged.

The following registers are under CCP:

**Table 11-1. CLKCTRL - Registers Under Configuration Change Protection**

Register	Key
CLKCTRL.MCLKCTRLA	IOREG
CLKCTRL.MCLKCTRLB	IOREG
CLKCTRL.MCLKLOCK	IOREG
CLKCTRL.XOSC32KCTRLA	IOREG
CLKCTRL.OSCHFCTRLA	IOREG
CLKCTRL.OSC32KCTRLA	IOREG

## 11.4 Register Summary

Offset	Name	Bit Pos.	7	6	5	4	3	2	1	0
0x00	<a href="#">MCLKCTRLA</a>	7:0	CLKOUT				CLKSEL[3:0]			
0x01	<a href="#">MCLKCTRLB</a>	7:0				PDIV[3:0]				PEN
0x02	<a href="#">MCLKLOCK</a>	7:0								LOCKEN
0x03	<a href="#">MCLKSTATUS</a>	7:0			PLLS	EXTS	XOSC32KS	OSC32KS	OSCHFS	SOSC
0x04	Reserved									
...										
0x07										
0x08	<a href="#">OSCHFCTRLA</a>	7:0	RUNSTDBY		FRQSEL[3:0]					AUTOTUNE
0x09	<a href="#">OSCHFTUNE</a>	7:0	TUNE[7:0]							
0x0A	Reserved									
...										
0x0F										
0x10	<a href="#">PLLCTRLA</a>	7:0	RUNSTDBY	SOURCE					MULFAC[1:0]	
0x11	Reserved									
...										
0x17										
0x18	<a href="#">OSC32KCTRLA</a>	7:0	RUNSTDBY							
0x19	Reserved									
...										
0x1B										
0x1C	<a href="#">XOSC32KCTRLA</a>	7:0	RUNSTDBY		CSUT[1:0]			SEL	LPMODE	ENABLE

## 11.5 Register Description

### 11.5.1 Main Clock Control A

**Name:** MCLKCTRLA  
**Offset:** 0x00  
**Reset:** 0x00  
**Property:** Configuration Change Protection

	7	6	5	4	3	2	1	0
	CLKOUT					CLKSEL[3:0]		
Access	R/W				R/W	R/W	R/W	R/W
Reset	0				0	0	0	0

**Bit 7 – CLKOUT** Peripheral Clock Out

When this bit is written to '1', the peripheral clock is output to the CLKOUT pin.

As long as the peripheral clock is running, the clock is output to the pin.

**Bits 3:0 – CLKSEL[3:0]** Clock Select

This bit field selects the source for the Main Clock (CLK\_MAIN).

Value	Name	Description
0x0	OSCHF	Internal High-Frequency Oscillator
0x1	OSC32K	32.768 kHz Internal Oscillator
0x2	XOSC32K	32.768 kHz External Crystal Oscillator
0x3	EXTCLK	External clock
Other	-	Reserved

### 11.5.2 Main Clock Control B

**Name:** MCLKCTRLB  
**Offset:** 0x01  
**Reset:** 0x00  
**Property:** Configuration Change Protection

	7	6	5	4	3	2	1	0	
					PDIV[3:0]			PEN	
Access					R/W	R/W	R/W	R/W	R/W
Reset					0	0	0	0	0

**Bits 4:1 – PDIV[3:0] Prescaler Division**

If the Prescaler Enable (PEN) bit is written to ‘1’, this bit field defines the division ratio of the main clock prescaler. This bit field can be written during run-time to vary the clock frequency of the system to suit the application requirements.

The user software must ensure a correct configuration of the input frequency (CLK\_MAIN) and prescaler settings so that the resulting frequency of CLK\_PER never exceeds the allowed maximum (refer to the *Electrical Characteristics* section).

Value	Name	Description
0x0	DIV2	CLK_MAIN divided by 2
0x1	DIV4	CLK_MAIN divided by 4
0x2	DIV8	CLK_MAIN divided by 8
0x3	DIV16	CLK_MAIN divided by 16
0x4	DIV32	CLK_MAIN divided by 32
0x5	DIV64	CLK_MAIN divided by 64
0x6–0x7	-	Reserved
0x8	DIV6	CLK_MAIN divided by 6
0x9	DIV10	CLK_MAIN divided by 10
0xA	DIV12	CLK_MAIN divided by 12
0xB	DIV24	CLK_MAIN divided by 24
0xC	DIV48	CLK_MAIN divided by 48
other	-	Reserved

**Bit 0 – PEN Prescaler Enable**

This bit must be written to ‘1’ to enable the prescaler. When enabled, the division ratio is selected by the PDIV bit field.

When this bit is written to ‘0’, the main clock will pass through undivided (CLK\_PER = CLK\_MAIN), regardless of the value of PDIV.

**11.5.3 Main Clock Lock**

**Name:** MCLKLOCK  
**Offset:** 0x02  
**Reset:** 0x00  
**Property:** Configuration Change Protection

Bit	7	6	5	4	3	2	1	0
								LOCKEN
Access								R/W
Reset								0

**Bit 0 – LOCKEN** Lock Enable

Writing this bit to '1' will lock the CLKCTRL.MCLKCTRLA and CLKCTRL.MCLKCTRLB registers and, if applicable, the calibration settings for the current main clock source from further software updates. Once locked, the CLKCTRL.MCLKLOCK registers cannot be accessed until the next hardware Reset.

This protects the CLKCTRL.MCLKCTRLA and CLKCTRL.MCLKCTRLB registers and calibration settings for the main clock source from unintentional modification by software.

### 11.5.4 Main Clock Status

**Name:** MCLKSTATUS  
**Offset:** 0x03  
**Reset:** 0x00  
**Property:** -

All Status bits, except SOSC, will be available only if the respective source is requested as the main clock or by a peripheral. If the oscillator RUNSTDBY bit is set and the oscillator is unused/not requested, these bits will be '0'.

Bit	7	6	5	4	3	2	1	0
			PLLS	EXTS	XOSC32KS	OSC32KS	OSCHFS	SOSC
Access			R	R	R	R	R	R
Reset			0	0	0	0	0	0

#### Bit 5 – PLLS PLL Status

Value	Description
0	PLL is not stable
1	PLL is stable

#### Bit 4 – EXTS External Clock Status

Value	Description
0	EXTCLK is not stable
1	EXTCLK is stable

#### Bit 3 – XOSC32KS 32.768 kHz External Crystal Oscillator Status

Value	Description
0	XOSC32K is not stable
1	XOSC32K is stable

#### Bit 2 – OSC32KS 32.768 kHz Ultra Low-Power Internal Oscillator Status

Value	Description
0	OSC32K is not stable
1	OSC32K is stable

#### Bit 1 – OSCHFS Internal High-Frequency Oscillator Status

Value	Description
0	OSCHF is not stable
1	OSCHF is stable

#### Bit 0 – SOSC Main Clock Oscillator Changing

Value	Description
0	The clock source for CLK_MAIN is not undergoing a switch
1	The clock source for CLK_MAIN is undergoing a switch and will change as soon as the new source is stable



### 11.5.5 Internal High-Frequency Oscillator Control A

**Name:** OSCHFCTRLA  
**Offset:** 0x08  
**Reset:** 0x0C  
**Property:** Configuration Change Protection

	Bit	7	6	5	4	3	2	1	0
		RUNSTDBY		FRQSEL[3:0]					AUTOTUNE
Access		R/W		R/W	R/W	R/W	R/W		R/W
Reset		0		0	0	1	1		0

**Bit 7 – RUNSTDBY** Run Standby

This bit enables the oscillator in Active, Idle and Standby sleep modes. The oscillator output is not sent to other peripherals if not requested. It takes two cycles to open the clock gate after a request, but the oscillator start-up time will be removed.

This bit is under Configuration Change Protection.

**Bits 5:2 – FRQSEL[3:0]** Frequency Select

This bit field selects the output frequency of the oscillator.

Value	Name	Description
0x0	1 MHz	1 MHz output
0x1	2 MHz	2 MHz output
0x2	3 MHz	3 MHz output
0x3	4 MHz	4 MHz output (default)
0x4	-	Reserved
0x5	8 MHz	8 MHz output
0x6	12 MHz	12 MHz output
0x7	16 MHz	16 MHz output
0x8	20 MHz	20 MHz output
0x9	24 MHz	24 MHz output
Other	-	Reserved

**Bit 0 – AUTOTUNE** Auto-Tune Enable

This bit enables the auto-tune feature of the oscillator. The auto-tune uses the 32.768 kHz crystal as a reference, and the crystal must be enabled for the auto-tune to work. The auto-tune will improve the accuracy of the oscillator.

### 11.5.6 Internal High-Frequency Oscillator Frequency Tune

**Name:** OSCHFTUNE  
**Offset:** 0x09  
**Reset:** 0x00  
**Property:** -

Bit	7	6	5	4	3	2	1	0
	TUNE[7:0]							
Access	R/W	R/W	R/W	R/W	R/W	R/W	R/W	R/W
Reset	0	0	0	0	0	0	0	0

#### Bits 7:0 – TUNE[7:0] User Frequency Tuning

The TUNE register allows for tuning the output frequency of the Internal High-Frequency Oscillator. The value in this register is on two's complement form and holds a 6-bit value with bit 5 holding the Sign bit.

Writes to bit 5 will be mirrored to bit 6 and 7, resulting in a register value which is represented in two's complement.

Writing to bits 6 and 7 has no effect.

The frequency can be tuned 32 steps down or 31 steps up from the oscillator's target frequency. This means the register's acceptable input values range is -32 to +31.

If the AUTOTUNE bit in the OSCHFCTRLA register is enabled, the TUNE value is locked. The TUNE register is updated with the latest tune value when AUTOTUNE is disabled.

### 11.5.7 PLL Control A

**Name:** PLLCTRLA  
**Offset:** 0x10  
**Reset:** 0x00  
**Property:** Configuration Change Protection

	Bit	7	6	5	4	3	2	1	0
		RUNSTDBY	SOURCE					MULFAC[1:0]	
Access		R/W	R/W					R/W	R/W
Reset		0	0					0	0

**Bit 7 – RUNSTDBY** Run Standby

Writing this bit to '1' enables the oscillator in Active, Idle and Standby sleep modes. The oscillator output is not sent to other peripherals, if not requested. It takes two cycles to open the clock gate after a request, but the oscillator start-up time will be removed.

**Bit 6 – SOURCE** Select Source for PLL

When this bit is set, the PLL will use the external clock as input. Otherwise, it uses the output from the OSCHF as input.

Value	Name	Description
0	OSCHF	OSCHF as PLL source
1	EXTCLK	External clock as PLL source

**Bits 1:0 – MULFAC[1:0]** Frequency Select

This bit field selects the output frequency of the oscillator.

Value	Name	Description
0x0	DISABLE	PLL is disabled
0x1	2x	2 x multiplication factor
0x2	3x	3 x multiplication factor
0x3	-	Reserved

**11.5.8 32.768 kHz Oscillator Control A**

**Name:** OSC32KCTRLA  
**Offset:** 0x18  
**Reset:** 0x00  
**Property:** Configuration Change Protection

Bit	7	6	5	4	3	2	1	0
	RUNSTDBY							
Access	R/W							
Reset	0							

**Bit 7 – RUNSTDBY** Run Standby

This bit forces the oscillator in ON state in all modes, even when unused by the system. In Standby sleep mode, this can be used to ensure immediate wake-up and avoid any waiting times for the oscillator start-up time.

When not requested by peripherals, the oscillator outputs are not provided.

It takes four oscillator cycles to open the clock gate after a request, but the oscillator analog start-up time will be removed when this bit is set.

### 11.5.9 32.768 kHz Crystal Oscillator Control A

**Name:** XOSC32KCTRLA  
**Offset:** 0x1C  
**Reset:** 0x00  
**Property:** Configuration Change Protection

The SEL and CSUT bits cannot be changed as long as the ENABLE bit is set or the XOSC32K Stable (XOSC32KS) bit in the CLKCTRL.MCLKSTATUS register is '1'.

To change the settings safely, the user must write a '0' to the ENABLE bit and wait until XOSC32KS is '0' before re-enabling the XOSC32K with new settings.

	7	6	5	4	3	2	1	0
Bit	RUNSTDBY		CSUT[1:0]			SEL	LPMODE	ENABLE
Access	R/W		R/W	R/W		R/W	R/W	R/W
Reset	0		0	0		0	0	0

#### Bit 7 – RUNSTDBY Run Standby

When the ENABLE bit is set to '1', writing this bit to '1' will force the oscillator in ON state in Active mode and all sleep modes. In any sleep mode, this can be used to ensure immediate wake-up and eliminate oscillator start-up time.

When the ENABLE bit is set to '1', writing this bit to '0' will make the crystal run only when requested in Active and Idle sleep modes.

The output of XOSC32K is not sent to other peripherals unless it is requested by one or more peripherals.

When the RUNSTDBY bit is set, there will be a delay of maximum three crystal oscillator cycles after a request, until the oscillator output is received, if the initial crystal start-up time has already ended.

#### Bits 5:4 – CSUT[1:0] Crystal Start-Up Time

This bit field selects the start-up time for the XOSC32K and is write-protected when the oscillator is enabled (ENABLE = 1).

If CLKSEL = 1, the start-up time will not be applied.

Value	Name	Description
0x0	1K	1k cycles
0x1	16K	16k cycles
0x2	32K	32k cycles
0x3	64K	64k cycles

#### Bit 2 – SEL Source Select

This bit selects the external source type. It is write-protected when the oscillator is enabled (ENABLE = 1).

Value	Description
0	External crystal
1	External clock on XTAL32K1 pin

#### Bit 1 – LPMODE Low-Power Mode

This bit sets the crystal oscillator in Low-Power mode.

Value	Description
0	Disabled
1	Enabled

#### Bit 0 – ENABLE Enable

When this bit is written to '1', the configuration of the respective input pins is overridden to XTAL32K1 and XTAL32K2. Also, the Source Select (SEL) bit and the Crystal Start-Up Time (CSUT) bit become read-only.

This bit is under Configuration Change Protection to prevent unintentional enabling or disabling of the oscillator.

## 12. SLPCTRL - Sleep Controller

### 12.1 Features

- Power Management for Adjusting Power Consumption and Functions
- Three Sleep Modes:
  - Idle
  - Standby
  - Power-Down
- Configurable Standby Mode where Peripherals Can Be Configured as ON or OFF

### 12.2 Overview

Sleep modes are used to shut down peripherals and clock domains in the device in order to save power. The Sleep Controller (SLPCTRL) controls and handles the transitions between Active and sleep modes.

There are four modes available: One Active mode in which software is executed, and three sleep modes. The available sleep modes are Idle, Standby and Power-Down.

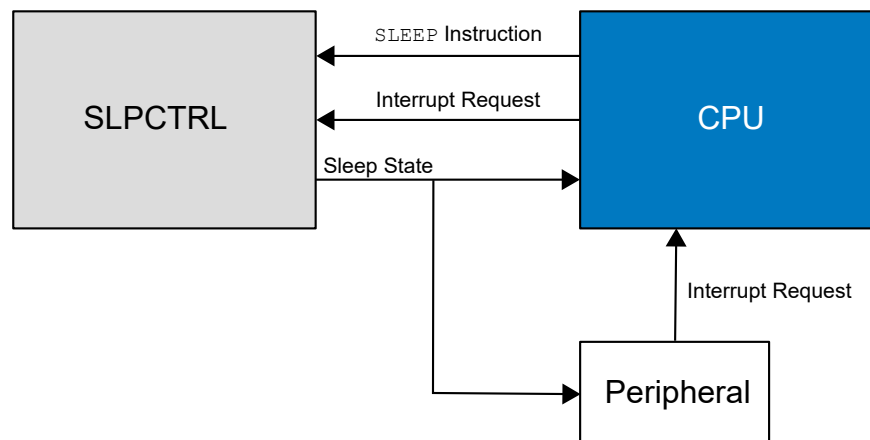
All sleep modes are available and can be entered from the Active mode. In Active mode, the CPU is executing application code. When the device enters sleep mode, the program execution is stopped. The application code decides which sleep mode to enter and when.

Interrupts are used to wake the device from sleep. The available interrupt wake-up sources depend on the configured sleep mode. When an interrupt occurs, the device will wake up and execute the Interrupt Service Routine before continuing normal program execution from the first instruction after the `SLEEP` instruction. Any Reset will take the device out of sleep mode.

The content of the register file, SRAM and registers, is kept during sleep. If a Reset occurs during sleep, the device will reset, start and execute from the Reset vector.

#### 12.2.1 Block Diagram

Figure 12-1. Sleep Controller in the System



### 12.3 Functional Description

#### 12.3.1 Initialization

To put the device into a sleep mode, follow these steps:

1. Configure and enable the interrupts that are able to wake the device from sleep.  
Also, enable global interrupts.



If there are no interrupts enabled when going to sleep, the device cannot wake up again. Only a Reset will allow the device to continue operation.

2. Select which sleep mode to enter and enable the Sleep Controller by writing to the Sleep Mode (SMODE) bit field and the Enable (SEN) bit in the Control A (SLPCTRL.CTRLA) register.  
The `SLEEP` instruction must be executed to make the device go to sleep.

### 12.3.2 Voltage Regulator Configuration

A voltage regulator is used to regulate the core voltage. The regulator can be configured to balance power consumption, wake-up time from Sleep, and maximum clock speed.

The Voltage Regulator Control (SLPCTRL.VREGCTRL) register is used to configure the regulator start-up time and power consumption. The Power Mode Select (PMODE) bit field in SLPCTRL.VREGCTRL can be set to make the regulator switch to Normal mode when OSC32K is the only oscillator enabled and if the device is in sleep mode. In Normal mode, the regulator consumes less power, but can supply only a limited amount of current, permitting only a low clock frequency.

The user may select one of the following Voltage Regulator Power modes:

**Table 12-1. Voltage Regulator Power Modes Description**

Voltage Regulator Power Mode	Description
Normal (AUTO)	Maximum performance in Active mode and Idle mode
Performance (FULL)	Maximum performance in all modes (Active and Sleep) and fast start-up from all sleep modes

### 12.3.3 Operation

#### 12.3.3.1 Sleep Modes

There are three sleep modes that can be enabled to reduce power consumption.

- Idle** The CPU stops executing code. All peripherals are running and all interrupt sources can wake the device.
- Standby** The user can configure peripherals to be enabled or not, using the respective RUNSTDBY bit. This means that the power consumption is highly dependent on what functionality is enabled, and thus may vary between the Idle and Power-Down modes.  
Operation in Standby mode is enabled for a peripheral by writing a '1' to the RUNSTDBY bit within the control register of each peripheral.
- Power-Down** The Watchdog Timer (WDT) and the Periodic Interrupt Timer (PIT) are active.  
The only wake-up sources are the pin change interrupt, TWI address match, and CCL (if filter and edge-detect are disabled).  
For temperature ranges above 70°C, the HTLLEN bit in the SLPCTRL.VREGCTRL register can be used to reduce power consumption (High-Temperature Low Leakage Enable).



**Important:** The TWI address match and CCL wake-up sources are not functional when High-Temperature Low Leakage Enable is activated and must be disabled by the user to avoid unpredictable behavior.

**Table 12-2. Sleep Mode Activity Overview**

Group	Peripheral		Active in Sleep Mode			
		Clock	Idle	Standby	Power-Down	
					HTLLEN=0	HTLLEN=1
Active Clock Domain	CPU	CLK_CPU				
	Peripherals	CLK_PER	X			
	RTC	CLK_RTC	X	X <sup>(1)</sup>	X <sup>(5)</sup>	X <sup>(5)</sup>
	WDT	CLK_WDT	X	X	X	X
	CCL	Several <sup>(2)</sup>	X	X <sup>(1)</sup>		
	ADC	CLK_PER	X	X <sup>(1)</sup>		
	PTC					
	TCA					
	TCB					
	TCD	CLK_TCD	X			
BOD (VLM)	CLK_BOD	X	X	X	X	
Oscillators	Main Clock Source		X	X <sup>(1)</sup>		
	RTC Clock Source		X	X <sup>(1)</sup>	X <sup>(5)</sup>	X <sup>(5)</sup>
	WDT Oscillator		X	X	X	X
	BOD Oscillator		X	X	X	X
Wake-Up Sources	PORT Interrupt		X	X	X <sup>(4)</sup>	X <sup>(4)</sup>
	TWI Address Match		X	X	X	
	RTC Interrupt		X	X <sup>(1)</sup>	X <sup>(5)</sup>	X <sup>(5)</sup>
	CCL		X	X <sup>(1)</sup>	X <sup>(3)</sup>	
	UART Start of Frame		X	X <sup>(1)</sup>		
	ADC Interrupt					
	PTC Interrupt					
	AC Interrupt					
	ZCD Interrupt					
	TCA Interrupt					
	TCB Interrupt					
BOD (VLM)		X	X	X	X	
All other Interrupts		X				



**Notes:**

1. The RUNSTDBY bit of the corresponding peripheral must be set for the module to run in Standby and be a wake-up source.
2. The CCL can internally select between multiple clock sources.
3. CCL can wake up the device if the path through LUTn is asynchronous (FILTSEL=0x0 and EDGEDET=0x0 in LUTnCTRLA register).
4. Only fully asynchronous pins can trigger an interrupt and wake up the device from all sleep modes, including modes where the Peripheral Clock (CLK\_PER) is stopped. Refer to the *I/O Multiplexing and Considerations* section for further details on which pins support fully asynchronous pin change sensing.
5. Only the PIT is available in the Power-Down sleep mode.

### 12.3.3.2 Wake-up Time

The normal wake-up time for the device is six main clock cycles (CLK\_PER), plus the time it takes to start the main clock source and the time it takes to start the regulator, if it has been switched off:

- In Idle mode, the main clock source is kept running to eliminate additional wake-up time
- In Standby mode, the main clock might be running depending on the peripheral configuration
- In Power-Down mode, only the OSC32K oscillator and the Real-Time Clock (RTC) may be running if it is used by the Brown-out Detector (BOD), Watchdog Timer (WDT) or Periodic Interrupt Timer (PIT). All the other clock sources will be OFF.

**Table 12-3. Sleep Modes and Start-up Time**

Sleep Mode	Start-up Time
Idle	Six clock cycles
Standby	Six clock cycles + one (OSC start-up + Regulator start-up)
Power-Down	Six clock cycles + one (OSC start-up + Regulator start-up)

The start-up time for the different clock sources is described in the *CLKCTRL - Clock Controller* section.

In addition to the normal wake-up time, it is possible to make the device wait until the BOD is ready before executing code. This is done by writing 0x3 to the BOD operation mode in Active and Idle (ACTIVE) bit field in the BOD Configuration (FUSE.BODCFG) fuse. If the BOD is ready before the normal wake-up time, the total wake-up time will be the same. If the BOD takes longer than the normal wake-up time, the wake-up time will be extended until the BOD is ready. This ensures correct supply voltage whenever code is executed.

### 12.3.4 Debug Operation

During run-time debugging, this peripheral will continue normal operation. The SLPCTRL is only affected by a break in the debug operation: If the SLPCTRL is in a sleep mode when a break occurs, the device will wake up, and the SLPCTRL will go to Active mode, even if there are no pending interrupt requests.

If the peripheral is configured to require periodic service by the CPU through interrupts or similar, improper operation or data loss may result during halted debugging.

### 12.4 Register Summary

Offset	Name	Bit Pos.	7	6	5	4	3	2	1	0
0x00	<a href="#">CTRLA</a>	7:0						SMODE[2:0]		SEN
0x01	<a href="#">VREGCTRL</a>	7:0				HTLLEN		PMODE[2:0]		

### 12.5 Register Description

### 12.5.1 Control A

**Name:** CTRLA  
**Offset:** 0x00  
**Reset:** 0x00  
**Property:** -

	7	6	5	4	3	2	1	0
					SMODE[2:0]			SEN
Access					R/W	R/W	R/W	R/W
Reset					0	0	0	0

**Bits 3:1 – SMODE[2:0] Sleep Mode**

Writing these bits selects the desired sleep mode when the Sleep Enable (SEN) bit is written to '1' and the `SLEEP` instruction is executed.

Value	Name	Description
0x0	IDLE	Idle mode enabled
0x1	STANDBY	Standby mode enabled
0x2	PDOWN	Power-Down mode enabled
Other	-	Reserved

**Bit 0 – SEN Sleep Enable**

This bit must be written to '1' before the `SLEEP` instruction is executed to make the microcontroller enter the selected sleep mode.

### 12.5.2 Voltage Regulator Control Register

**Name:** VREGCTRL  
**Offset:** 0x01  
**Reset:** 0x00  
**Property:** Configuration Change Protection

	7	6	5	4	3	2	1	0
				HTLLEN	PMODE[2:0]			
Access				R/W	R/W			R/W
Reset				0	0			0

#### Bit 4 – HTLLEN High-Temperature Low Leakage Enable

This bit is write-protected.

When writing this bit to '1', the leakage is reduced when operating at a temperature above 70°C. This bit has an effect only in Power-Down mode when PMODE is set to AUTO. To have effect, it must be written before executing the SLEEP instruction.



This feature allows an additional power-saving feature, but the TWI address match and CCL wake-up sources must be disabled in software before setting this bit.

Value	Name	Description
0	OFF	High-temperature low leakage disabled
1	ON	High-temperature low leakage enabled

#### Bits 2:0 – PMODE[2:0] Power Mode Select

This bit field is write-protected.

Value	Name	Description
0x0	AUTO	In Auto mode, the regulator will run at the full performance unless the 32.768 kHz oscillator is selected, then it runs in a lower power mode.
0x1	FULL	Full performance voltage regulator drive strength in all modes.
Other	-	Reserved

## 13. RSTCTRL - Reset Controller

### 13.1 Features

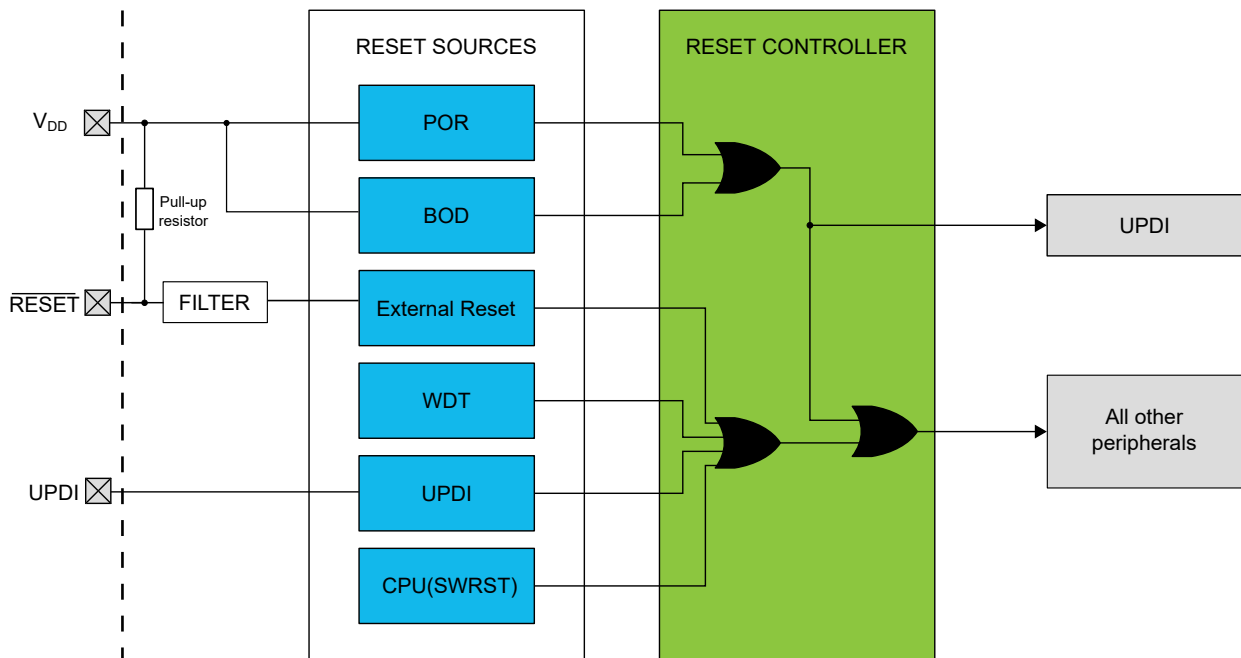
- Returns the Device to an Initial State after a Reset
- Identifies the Previous Reset Source
- Power Supply Reset Sources:
  - Power-on Reset (POR)
  - Brown-out Detector (BOD) Reset
- User Reset Sources:
  - External Reset (RESET)
  - Watchdog Timer (WDT) Reset
  - Software Reset (SWRST)
  - Unified Program and Debug Interface (UPDI) Reset

### 13.2 Overview

The Reset Controller (RSTCTRL) manages the Reset of the device. When receiving a Reset request, it sets the device to an initial state and allows the Reset source to be identified by the software. The Reset controller can also be used to issue a Software Reset (SWRST).

#### 13.2.1 Block Diagram

Figure 13-1. Reset System Overview



#### 13.2.2 Signal Description

Signal	Description	Type
RESET	External Reset (active-low)	Digital input

.....continued		
Signal	Description	Type
UPDI	Unified Program and Debug Interface	Digital input

## 13.3 Functional Description

### 13.3.1 Initialization

The RSTCTRL is always enabled, but some of the Reset sources must be enabled individually (either by Fuses or by software) before they can request a Reset.

After a Reset from any source, the registers in the device with automatic loading from the Fuses or from the Signature Row are updated.

### 13.3.2 Operation

#### 13.3.2.1 Reset Sources

After any Reset, the source that caused the Reset is found in the Reset Flag (RSTCTRL.RSTFR) register. The user can identify the previous Reset source by reading this register in the software application.

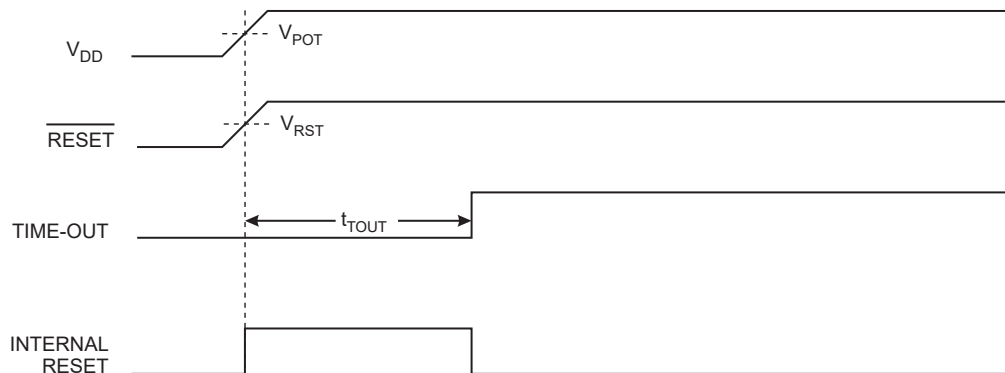
There are two types of Resets based on the source:

- Power Supply Reset Sources:
  - Power-on Reset (POR)
  - Brown-out Detector (BOD) Reset
- User Reset Sources:
  - External Reset ( $\overline{\text{RESET}}$ )
  - Watchdog Timer (WDT) Reset
  - Software Reset (SWRST)
  - Unified Program and Debug Interface (UPDI) Reset

##### 13.3.2.1.1 Power-on Reset (POR)

The purpose of the Power-on Reset (POR) is to ensure a safe start-up of logic and memories. It is generated by an on-chip detection circuit and is always enabled. The POR is activated when the  $V_{DD}$  rises and reaches the POR threshold voltage ( $V_{POT}$ ), starting the reset sequence. Before  $V_{POT}$  has been reached, the external  $\overline{\text{RESET}}$  pin keeps the device in reset, either through the internal pull-up to  $V_{DD}$  or by external control.

Figure 13-2. MCU Start-Up,  $\overline{\text{RESET}}$  Tied to  $V_{DD}$

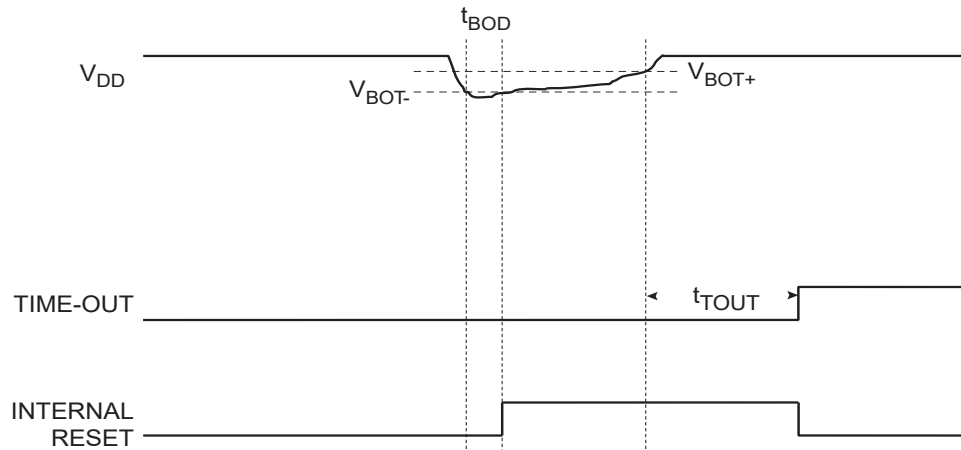


##### 13.3.2.1.2 Brown-out Detector (BOD) Reset

The Brown-out Detector (BOD) needs to be enabled by the user. The BOD is preventing code execution when the voltage drops below a set threshold. This will ensure the voltage level needed for the oscillator to run at the speed required by the application and will avoid code corruption due to low-voltage level.

The BOD issues a System Reset and is not released until the voltage level increases above the set threshold. The on-chip BOD circuit will monitor the  $V_{DD}$  level during operation by comparing it to a fixed trigger level. The trigger level for the BOD must be selected by the BOD Configuration (FUSE.BODCFG) fuse.

**Figure 13-3. Brown-out Detector Reset**



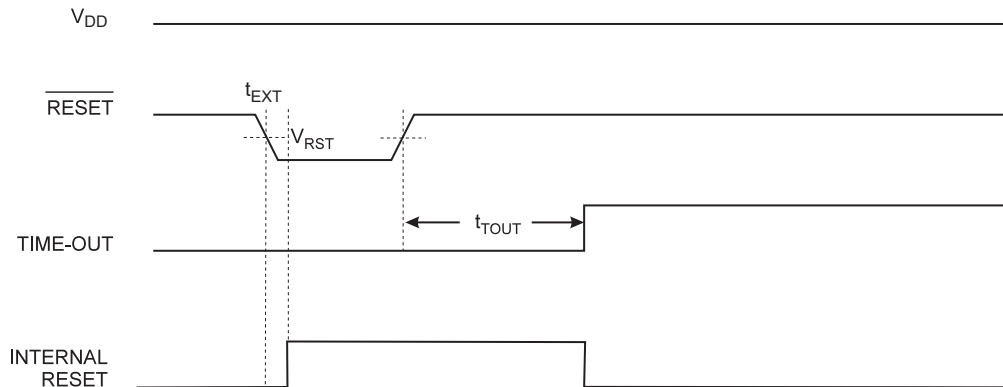
#### 13.3.2.1.3 External Reset ( $\overline{\text{RESET}}$ )

The  $\overline{\text{RESET}}$  pin requires a noise filter that eliminates short, low-going pulses. Filtering the input assures that an external Reset event is only issued when the  $\overline{\text{RESET}}$  has been low for a minimum amount of time. See the *Electrical Characteristics* section for the minimum pulse width of the  $\overline{\text{RESET}}$  signal.

The external Reset is enabled by configuring the Reset Pin Configuration (RSTPINCFG) bits in the System Configuration 0 (FUSE.SYSCFG0) fuse.

When enabled, the external Reset requests a Reset as long as the  $\overline{\text{RESET}}$  pin is low. The device will stay in Reset until the  $\overline{\text{RESET}}$  pin is high again.

**Figure 13-4. External Reset Characteristics**



#### 13.3.2.1.4 Watchdog Timer (WDT) Reset

The Watchdog Timer (WDT) is a system function which monitors the correct operation of the program. If the WDT is not handled by software according to the programmed time-out period, a Watchdog Reset will be issued. More details can be found in the WDT section.

#### 13.3.2.1.5 Software Reset (SWRST)

The software Reset makes it possible to issue a System Reset from the software. The Reset is generated by writing a '1' to the Software Reset (SWRST) bit in the Software Reset (RSTCTRL.SWRR) register.

The Reset sequence will start immediately after the bit is written.

### 13.3.2.1.6 Unified Program and Debug Interface (UPDI) Reset

The Unified Program and Debug Interface (UPDI) contains a separate Reset source used to reset the device during external programming and debugging. The Reset source is accessible only from external debuggers and programmers. More details can be found in the UPDI section.

### 13.3.2.1.7 Domains Affected By Reset

The following logic domains are affected by the different Reset sources:

**Table 13-1. Logic Domains Affected by Various Resets**

Reset Source	Fuses are Reloaded	Reset of BOD Configuration	Reset of UPDI	Reset of Other Volatile Logic
POR	X	X	X	X
BOD	X		X	X
Software Reset	X			X
External Reset	X			X
Watchdog Reset	X			X
UPDI Reset	X			X

### 13.3.2.2 Reset Time

The Reset time can be split into two parts.

The first part is when any of the Reset sources are active. This part depends on the input to the Reset sources. The external Reset is active as long as the  $\overline{\text{RESET}}$  pin is low. The Power-on Reset (POR) and the Brown-out Detector (BOD) are active as long as the supply voltage is below the Reset source threshold.

The second part is when all the Reset sources are released, and an internal Reset initialization of the device is done. This time will be increased with the start-up time given by the Start-Up Time Setting (SUT) bit field in the System Configuration 1 (FUSE.SYSCFG1) fuse. The internal Reset initialization time will also increase if the Cyclic Redundancy Check Memory Scan (CRCSCAN) is configured to run at start-up. This configuration can be changed in the CRC Source (CRCSRC) bit field in the System Configuration 0 (FUSE.SYSCFG0) fuse.

### 13.3.3 Sleep Mode Operation

The RSTCTRL operates in Active mode and in all sleep modes.

### 13.3.4 Configuration Change Protection

This peripheral has registers that are under Configuration Change Protection (CCP). To write to these registers, a certain key must first be written to the CPU.CCP register, followed by a write access to the protected bits within four CPU instructions.

Attempting to write to a protected register without following the appropriate CCP unlock sequence leaves the protected register unchanged.

The following registers are under CCP:

**Table 13-2. RSTCTRL - Registers Under Configuration Change Protection**

Register	Key
RSTCTRL.SWRR	IOREG



### 13.4 Register Summary

Offset	Name	Bit Pos.	7	6	5	4	3	2	1	0
0x00	<a href="#">RSTFR</a>	7:0			UPDIRF	SWRF	WDRF	EXTRF	BORF	PORF
0x01	<a href="#">SWRR</a>	7:0								SWRST

### 13.5 Register Description

### 13.5.1 Reset Flag Register

**Name:** RSTFR  
**Offset:** 0x00  
**Reset:** 0xFF  
**Property:** -

The Reset flags can be cleared by writing a '1' to the respective flag. All flags will be cleared by a Power-on Reset (POR), with the exception of the Power-on Reset (PORF) flag. All flags will be cleared by a Brown-out Reset (BOR), with the exception of the Power-on Reset (PORF) and Brown-out Reset (BORF) flags.

Bit	7	6	5	4	3	2	1	0
			UPDIRF	SWRF	WDRF	EXTRF	BORF	PORF
Access			R/W	R/W	R/W	R/W	R/W	R/W
Reset			x	x	x	x	x	x

**Bit 5 – UPDIRF** UPDI Reset Flag

This bit is set to '1' if a UPDI Reset has occurred.

**Bit 4 – SWRF** Software Reset Flag

This bit is set to '1' if a Software Reset has occurred.

**Bit 3 – WDRF** Watchdog Reset Flag

This bit is set to '1' if a Watchdog Reset has occurred.

**Bit 2 – EXTRF** External Reset Flag

This bit is set to '1' if an External Reset has occurred.

**Bit 1 – BORF** Brown-out Reset Flag

This bit is set to '1' if a Brown-out Reset has occurred.

**Bit 0 – PORF** Power-on Reset Flag

This bit is set to '1' if a Power-on Reset has occurred.

13.5.2 Software Reset Register

**Name:** SWRR  
**Offset:** 0x01  
**Reset:** 0x00  
**Property:** Configuration Change Protection

Bit	7	6	5	4	3	2	1	0
								SWRST
Access								R/W
Reset								0

**Bit 0 – SWRST** Software Reset  
When this bit is written to '1', a Software Reset will occur.  
This bit will always read as '0'.

## 14. CPUINT - CPU Interrupt Controller

### 14.1 Features

- Short and Predictable Interrupt Response Time
- Separate Interrupt Configuration and Vector Address for Each Interrupt
- Interrupt Prioritizing by Level and Vector Address
- Non-Maskable Interrupts (NMI) for Critical Functions
- Two Interrupt Priority Levels: 0 (Normal) and 1 (High):
  - One of the interrupt requests can optionally be assigned as a priority level 1 interrupt
  - Optional round robin priority scheme for priority level 0 interrupts
- Interrupt Vectors Optionally Placed in the Application Section or the Boot Loader Section
- Selectable Compact Vector Table (CVT)

### 14.2 Overview

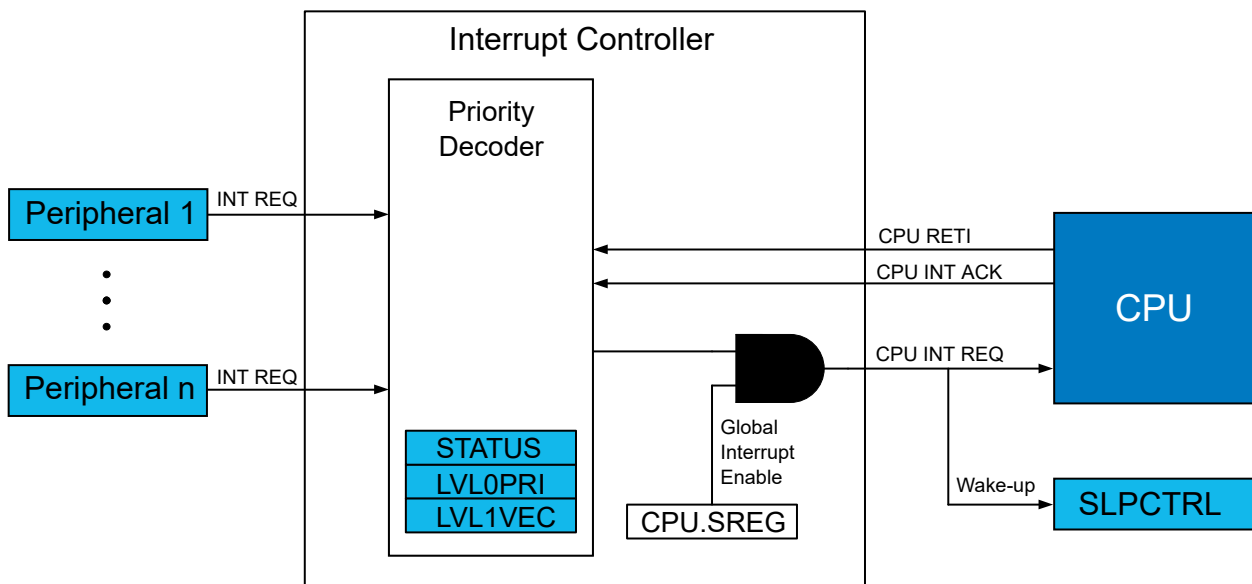
An interrupt request signals a change of state inside a peripheral and can be used to alter the program execution. The peripherals can have one or more interrupts. All interrupts are individually enabled and configured. When an interrupt is enabled and configured, it will generate an interrupt request when the interrupt condition occurs.

The CPU Interrupt Controller (CPUINT) handles and prioritizes the interrupt requests. When an interrupt is enabled and the interrupt condition occurs, the CPUINT will receive the interrupt request. Based on the interrupt's priority level and the priority level of any ongoing interrupt, the interrupt request is either acknowledged or kept pending until it has priority. After returning from the interrupt handler, the program execution continues from where it was before the interrupt occurred, and any pending interrupts are served after one instruction is executed.

The CPUINT offers NMI for critical functions, one selectable high-priority interrupt and an optional round robin scheduling scheme for normal-priority interrupts. The round robin scheduling ensures that all interrupts are serviced within a certain amount of time.

#### 14.2.1 Block Diagram

Figure 14-1. CPUINT Block Diagram



## 14.3 Functional Description

### 14.3.1 Initialization

An interrupt must be initialized in the following order:

1. Configure the CPUINT if the default configuration is not adequate (optional):
  - Vector handling is configured by writing to the respective bits (IVSEL and CVT) in the Control A (CPUINT.CTRLA) register.
  - Vector prioritizing by round robin is enabled by writing a '1' to the Round Robin Priority Enable (LVL0RR) bit in CPUINT.CTRLA.
  - Select the Priority Level 1 vector by writing the interrupt vector number to the Interrupt Vector with Priority Level 1 (CPUINT.LVL1VEC) register.
2. Configure the interrupt conditions within the peripheral and enable the peripheral's interrupt.
3. Enable interrupts globally by writing a '1' to the Global Interrupt Enable (I) bit in the CPU Status (CPU.SREG) register.

### 14.3.2 Operation

#### 14.3.2.1 Enabling, Disabling and Resetting

The global enabling of interrupts is done by writing a '1' to the Global Interrupt Enable (I) bit in the CPU Status (CPU.SREG) register. To disable interrupts globally, write a '0' to the I bit in CPU.SREG.

The desired interrupt lines must also be enabled in the respective peripheral by writing to the peripheral's Interrupt Control (*peripheral*.INTCTRL) register.

The interrupt flags are not automatically cleared after the interrupt is executed. The respective INTFLAGS register descriptions provide information on how to clear specific flags.

#### 14.3.2.2 Interrupt Vector Locations

The interrupt vector placement is dependent on the value of the Interrupt Vector Select (IVSEL) bit in the Control A (CPUINT.CTRLA) register. Refer to the IVSEL description in [CPUINT.CTRLA](#) for the possible locations.

If the program never enables an interrupt source, the interrupt vectors are not used, and the regular program code can be placed at these locations.

#### 14.3.2.3 Interrupt Response Time

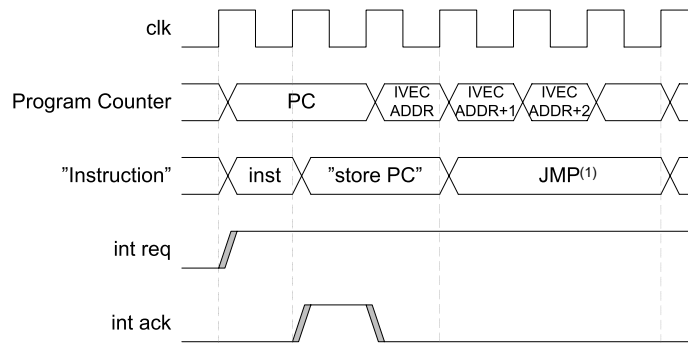
The minimum interrupt response time is represented in the following table.

**Table 14-1. Minimum Interrupt Response Time**

	Flash Size > 8 KB	Flash Size ≤ 8 KB
Finish ongoing instruction	One cycle	One cycle
Store PC to stack	Two cycles	Two cycles
Jump to interrupt handler	Three cycles ( <code>jmp</code> )	Two cycles ( <code>rjmp</code> )

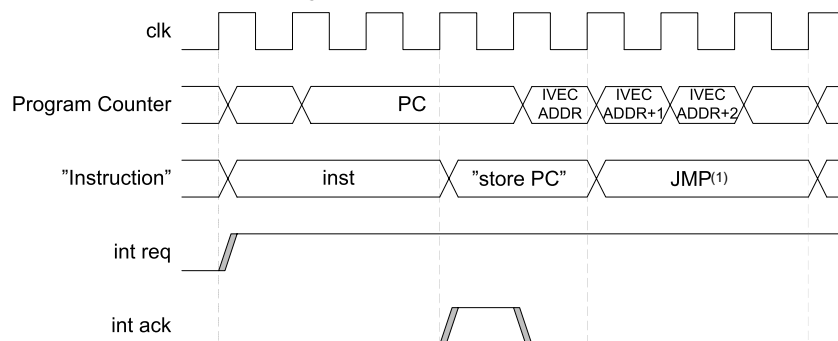
After the Program Counter is pushed on the stack, the program vector for the interrupt is executed. See the following figure.

**Figure 14-2. Interrupt Execution of Single-Cycle Instruction**



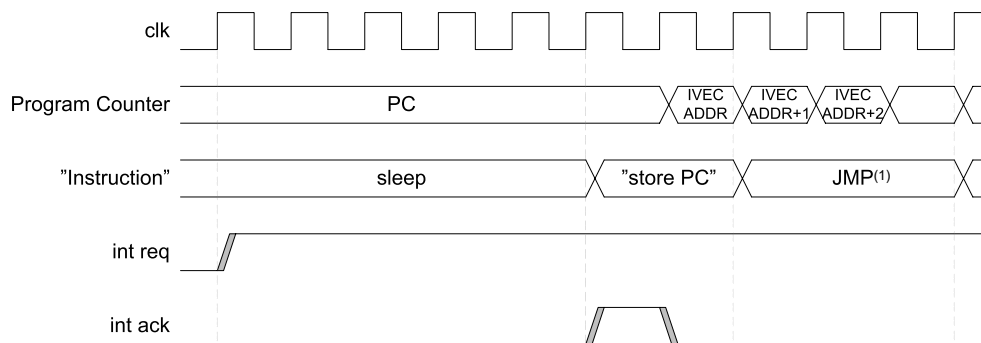
If an interrupt occurs during the execution of a multi-cycle instruction, the instruction is completed before the interrupt is served, as shown in the following figure.

**Figure 14-3. Interrupt Execution of Multi-Cycle Instruction**



If an interrupt occurs when the device is in a sleep mode, the interrupt execution response time is increased by five clock cycles, as shown in the figure below. Also, the response time is increased by the start-up time from the selected sleep mode.

**Figure 14-4. Interrupt Execution From Sleep**



A return from an interrupt handling routine takes four to five clock cycles, depending on the size of the Program Counter. During these clock cycles, the Program Counter is popped from the stack, and the Stack Pointer is incremented.

**Note:**

1. Devices with 8 KB of Flash or less use `RJMP` instead of `JMP`, which takes only two clock cycles.

### 14.3.2.4 Interrupt Priority

All interrupt vectors are assigned to one of three possible priority levels, as shown in the table below. An interrupt request from a high-priority source will interrupt any ongoing interrupt handler from a normal-priority source. When returning from the high-priority interrupt handler, the execution of the normal-priority interrupt handler will resume.

**Table 14-2. Interrupt Priority Levels**

Priority	Level	Source
Highest	Non-Maskable Interrupt	Device-dependent and statically assigned
...	Level 1 (high priority)	One vector is optionally user selectable as level 1
Lowest	Level 0 (normal priority)	The remaining interrupt vectors

**14.3.2.4.1 Non-Maskable Interrupts**

A Non-Maskable Interrupt (NMI) will be executed regardless of the setting of the I bit in CPU.SREG. An NMI will never change the I bit. No other interrupt can interrupt an NMI handler. If more than one NMI is requested at the same time, the priority is static according to the interrupt vector address, where the lowest address has the highest priority.

Which interrupts are non-maskable is device-dependent and not subject to configuration. Non-maskable interrupts must be enabled before they can be used. Refer to the interrupt vector mapping of the device for available NMI lines.

**14.3.2.4.2 High-Priority Interrupt**

It is possible to assign one interrupt request to level 1 (high priority) by writing its interrupt vector number to the CPUINT.LVL1VEC register. This interrupt request will have a higher priority than the other (normal priority) interrupt requests. The priority level 1 interrupts will interrupt the level 0 interrupt handlers.

**14.3.2.4.3 Normal-Priority Interrupts**

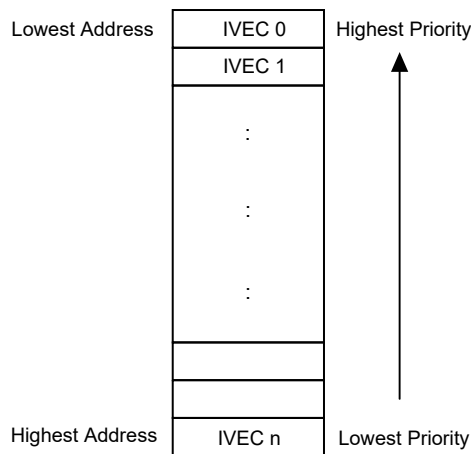
All interrupt vectors other than NMI are assigned to priority level 0 (normal) by default. The user may override this by assigning one of these vectors as a high-priority vector. The device will have many normal-priority vectors, and some of these may be pending at the same time. Two different scheduling schemes are available to choose which of the pending normal-priority interrupts to service first: Static or round robin.

IVEC is the interrupt vector mapping, as listed in the *Peripherals and Architecture* section. The following sections use IVEC to explain the scheduling schemes. IVEC0 is the Reset vector, IVEC1 is the NMI vector, and so on. In a vector table with n+1 elements, the vector with the highest vector number is denoted IVECn. Reset, non-maskable interrupts and high-level interrupts are included in the IVEC map, but will always be prioritized over the normal-priority interrupts.

**Static Scheduling**

If several level 0 interrupt requests are pending at the same time, the one with the highest priority is scheduled for execution first. The following figure illustrates the default configuration, where the interrupt vector with the lowest address has the highest priority.

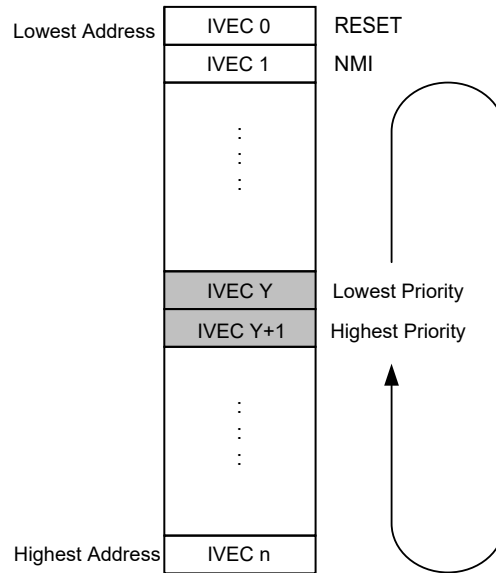
**Figure 14-5. Default Static Scheduling**



**Modified Static Scheduling**

The default priority can be changed by writing a vector number to the CPUINT.LVL0PRI register. This vector number will be assigned the lowest priority. The next interrupt vector in the IVEC will have the highest priority among the LVL0 interrupts, as shown in the following figure.

**Figure 14-6. Static Scheduling when CPUINT.LVL0PRI is Different From Zero**



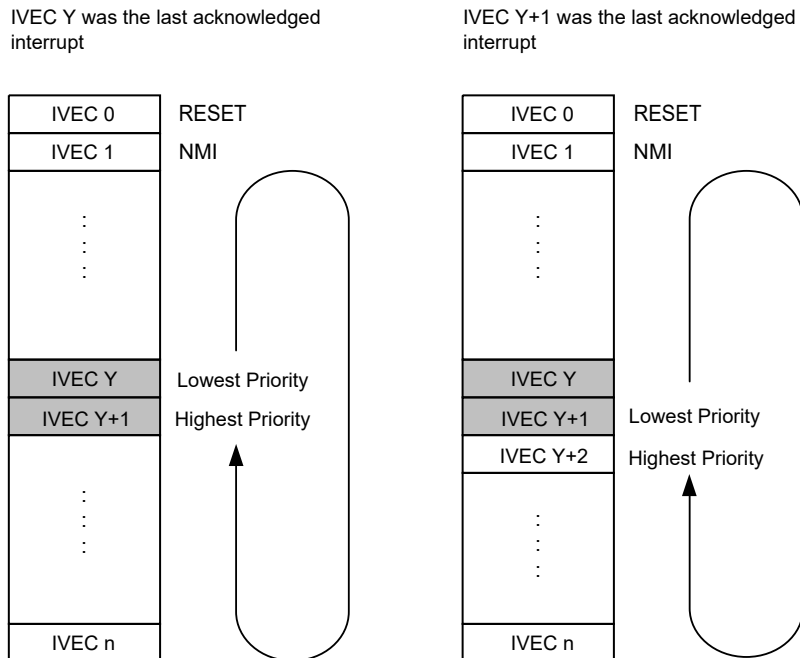
Here, value Y has been written to CPUINT.LVL0PRI, so that interrupt vector Y+1 has the highest priority. Note that, in this case, the priorities will wrap so that the lowest address no longer has the highest priority. This does not include RESET and NMI, which will always have the highest priority.

Refer to the interrupt vector mapping of the device for available interrupt requests and their interrupt vector number.

**Round Robin Scheduling**

The static scheduling may prevent some interrupt requests from being serviced. To avoid this, the CPUINT offers round robin scheduling for normal-priority (LVL0) interrupts. In the round robin scheduling, the CPUINT.LVL0PRI register stores the last acknowledged interrupt vector number. This register ensures that the last acknowledged interrupt vector gets the lowest priority and is automatically updated by the hardware. The following figure illustrates the priority order after acknowledging IVEC Y and after acknowledging IVEC Y+1.

**Figure 14-7. Round Robin Scheduling**



The round robin scheduling for LVL0 interrupt requests is enabled by writing a '1' to the Round Robin Priority Enable (LVL0RR) bit in the Control A (CPUINT.CTRLA) register.



### 14.3.2.5 Compact Vector Table

The Compact Vector Table (CVT) is a feature to allow writing of compact code by having all level 0 interrupts share the same interrupt vector number. Thus, the interrupts share the same Interrupt Service Routine (ISR). This reduces the number of interrupt handlers and thereby frees up memory that can be used for the application code.

When CVT is enabled by writing a '1' to the CVT bit in the Control A (CPUINT.CTRLA) register, the vector table contains these three interrupt vectors:

1. The non-maskable interrupts (NMI) at vector address 1.
2. The Priority Level 1 (LVL1) interrupt at vector address 2.
3. All priority level 0 (LVL0) interrupts at vector address 3.

This feature is most suitable for devices with limited memory and applications using a small number of interrupt generators.

### 14.3.3 Debug Operation

When using a level 1 priority interrupt, it is important to make sure the Interrupt Service Routine is configured correctly as it may cause the application to be stuck in an interrupt loop with level 1 priority.

By reading the CPUINT STATUS (CPUINT.STATUS) register, it is possible to see if the application has executed the correct `RETI` (interrupt return) instruction. The CPUINT.STATUS register contains state information, which ensures that the CPUINT returns to the correct interrupt level when the `RETI` instruction is executed at the end of an interrupt handler. Returning from an interrupt will return the CPUINT to the state it had before entering the interrupt.

### 14.3.4 Configuration Change Protection

This peripheral has registers that are under Configuration Change Protection (CCP). To write to these registers, a certain key must first be written to the CPU.CCP register, followed by a write access to the protected bits within four CPU instructions.

Attempting to write to a protected register without following the appropriate CCP unlock sequence leaves the protected register unchanged.

The following registers are under CCP:

**Table 14-3. CPUINT - Registers under Configuration Change Protection**

Register	Key
IVSEL in CPUINT.CTRLA	IOREG
CVT in CPUINT.CTRLA	IOREG

## 14.4 Register Summary

Offset	Name	Bit Pos.	7	6	5	4	3	2	1	0
0x00	<a href="#">CTRLA</a>	7:0		IVSEL	CVT					LVL0RR
0x01	<a href="#">STATUS</a>	7:0	NMIEX						LVL1EX	LVL0EX
0x02	<a href="#">LVL0PRI</a>	7:0	LVL0PRI[7:0]							
0x03	<a href="#">LVL1VEC</a>	7:0	LVL1VEC[7:0]							

## 14.5 Register Description

**14.5.1 Control A**

**Name:** CTRLA  
**Offset:** 0x00  
**Reset:** 0x00  
**Property:** Configuration Change Protection

	7	6	5	4	3	2	1	0
Access		IVSEL	CVT					LVL0RR
Reset		R/W	R/W					R/W
		0	0					0

**Bit 6 – IVSEL** Interrupt Vector Select

This bit is protected by the Configuration Change Protection mechanism.

Value	Description
0	Interrupt vectors are placed at the start of the application section of the Flash
1	Interrupt vectors are placed at the start of the boot section of the Flash

**Bit 5 – CVT** Compact Vector Table

This bit is protected by the Configuration Change Protection mechanism.

Value	Description
0	Compact Vector Table function is disabled
1	Compact Vector Table function is enabled

**Bit 0 – LVL0RR** Round Robin Priority Enable

This bit is not protected by the Configuration Change Protection mechanism.

Value	Description
0	Priority is fixed for priority level 0 interrupt requests: The lowest interrupt vector address has the highest priority
1	The round robin priority scheme is enabled for priority level 0 interrupt requests

**14.5.2 Status**

**Name:** STATUS  
**Offset:** 0x01  
**Reset:** 0x00  
**Property:** -

	7	6	5	4	3	2	1	0
	NMIEX						LVL1EX	LVL0EX
Access	R						R	R
Reset	0						0	0

**Bit 7 – NMIEX** Non-Maskable Interrupt Executing

This flag is set if a non-maskable interrupt is executing. The flag is cleared when returning (RETI) from the interrupt handler.

**Bit 1 – LVL1EX** Level 1 Interrupt Executing

This flag is set when a priority level 1 interrupt is executing, or when the interrupt handler has been interrupted by an NMI. The flag is cleared when returning (RETI) from the interrupt handler.

**Bit 0 – LVL0EX** Level 0 Interrupt Executing

This flag is set when a priority level 0 interrupt is executing, or when the interrupt handler has been interrupted by a priority level 1 interrupt or an NMI. The flag is cleared when returning (RETI) from the interrupt handler.

### 14.5.3 Interrupt Priority Level 0

**Name:** LVL0PRI  
**Offset:** 0x02  
**Reset:** 0x00  
**Property:** -

Bit	7	6	5	4	3	2	1	0
	LVL0PRI[7:0]							
Access	R/W	R/W	R/W	R/W	R/W	R/W	R/W	R/W
Reset	0	0	0	0	0	0	0	0

**Bits 7:0 – LVL0PRI[7:0]** Interrupt Priority Level 0

This register is used to modify the priority of the LVL0 interrupts. See the section [Normal-Priority Interrupts](#) for more information.

**14.5.4 Interrupt Vector with Priority Level 1**

**Name:** LVL1VEC  
**Offset:** 0x03  
**Reset:** 0x00  
**Property:** -

	7	6	5	4	3	2	1	0
	LVL1VEC[7:0]							
Access	R/W	R/W	R/W	R/W	R/W	R/W	R/W	R/W
Reset	0	0	0	0	0	0	0	0

**Bits 7:0 – LVL1VEC[7:0] Interrupt Vector with Priority Level 1**

This bit field contains the number of the single vector with increased priority level 1 (LVL1). If this bit field has the value 0x00, no vector has LVL1. Consequently, the LVL1 interrupt is disabled.

## 15. EVSYS - Event System

### 15.1 Features

- System for Direct Peripheral-to-Peripheral Signaling
- Peripherals Can Directly Produce, Use, and React to Peripheral Events
- Short and Predictable Response Time
- Up to 10 Parallel Event Channels Available
- Each Channel is Driven by One Event Generator and Can Have Multiple Event Users
- Events Can be Sent and/or Received by Most Peripherals and by Software
- The Event System Works in Active, Idle, and Standby Sleep Modes

### 15.2 Overview

The Event System (EVSYS) enables direct peripheral-to-peripheral signaling. It allows a change in one peripheral (the event generator) to trigger actions in other peripherals (the event users) through event channels, without using the CPU. It is designed to provide a short and predictable response time between peripherals, allowing for autonomous peripheral control and interaction, and for synchronized timing of actions in several peripheral modules. Thus, it is a powerful tool for reducing the complexity, size, and execution time of the software.

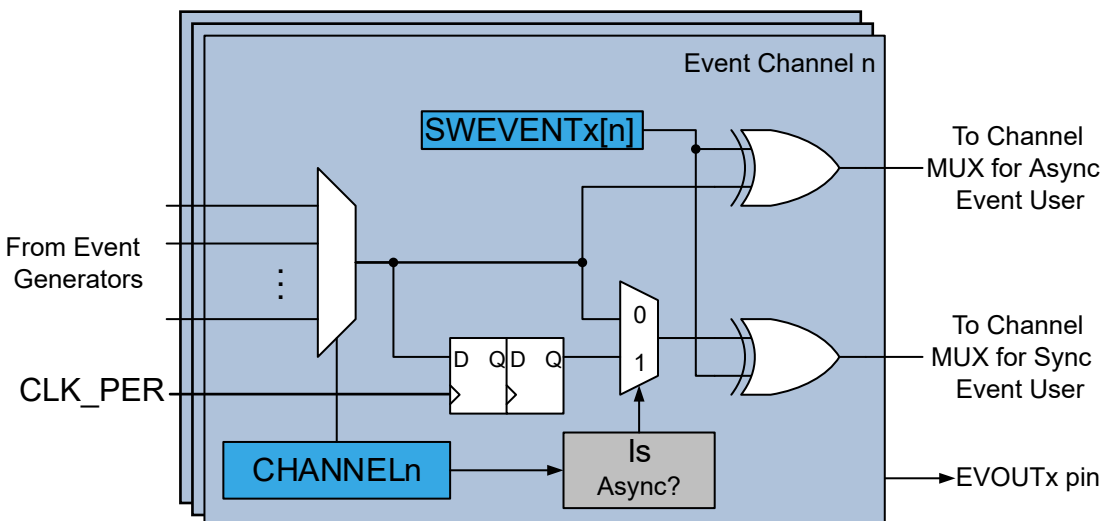
A change of the event generator's state is referred to as an event and usually corresponds to one of the peripheral's interrupt conditions. Events can be forwarded directly to other peripherals using the dedicated event routing network. The routing of each channel is configured in software, including event generation and use.

Only one event signal can be routed on each channel. Multiple peripherals can use events from the same channel.

The EVSYS can connect peripherals such as ADCs, analog comparators, I/O PORT pins, the real-time counter, timer/counters, and the configurable custom logic peripheral. Events can also be generated from software.

#### 15.2.1 Block Diagram

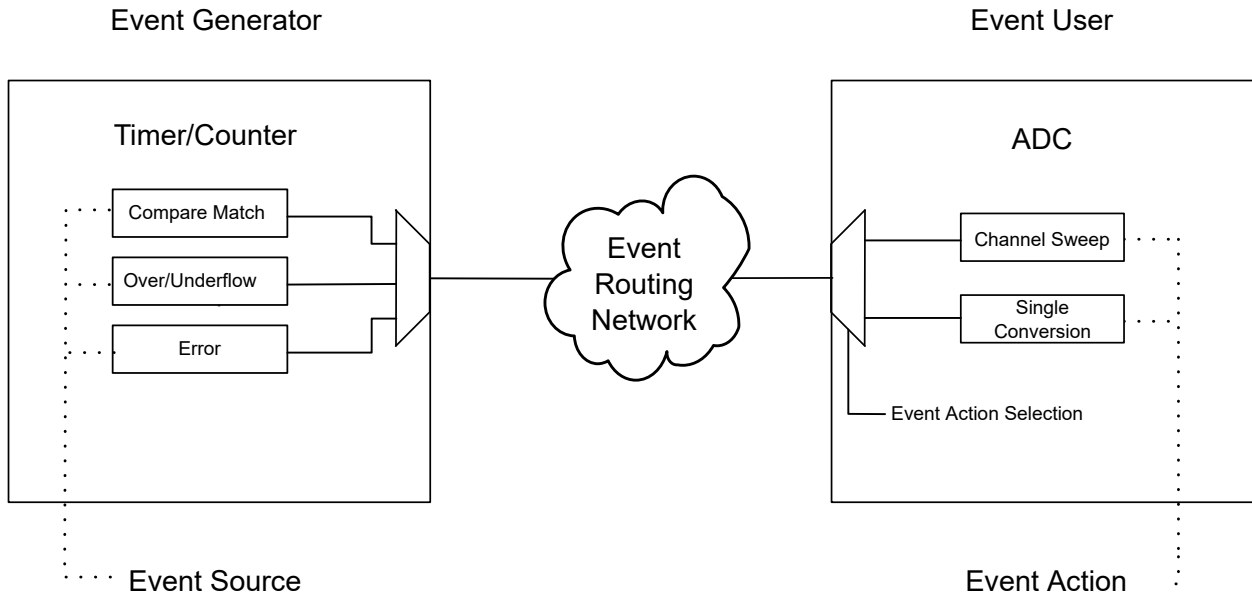
Figure 15-1. Block Diagram



The block diagram shows the operation of an event channel. A multiplexer controlled by Channel n Generator Selection (EVSYS.CHANNELn) register at the input selects which of the event sources to route onto the event channel. Each event channel has two subchannels: one asynchronous and one synchronous. A synchronous user will listen to the synchronous subchannel, and an asynchronous user will listen to the asynchronous subchannel.

An event signal from an asynchronous source will be synchronized by the Event System before being routed to the synchronous subchannel. An asynchronous event signal to be used by a synchronous consumer must last for at least one peripheral clock cycle to ensure that it will propagate through the synchronizer. The synchronizer will delay such an event between two and three clock cycles, depending on when the event occurs.

**Figure 15-2. Example of Event Source, Generator, User, and Action**



### 15.2.2 Signal Description

Signal	Type	Description
EVOUTx	Digital output	Event output, one output per I/O Port

## 15.3 Functional Description

### 15.3.1 Initialization

To utilize events, the Event System, the generating peripheral, and the peripheral(s) using the event must be set up accordingly:

1. Configure the generating peripheral appropriately. For example, if the generating peripheral is a timer, set the prescaling, the Compare register, etc., so that the desired event is generated.
2. Configure the event user peripheral(s) appropriately. For example, if the ADC is the event user, set the ADC prescaler, resolution, conversion time, etc., as desired, and configure the ADC conversion to start at the reception of an event.
3. Configure the Event System to route the desired source. In this case, the Timer/Compare match to the desired event channel. This may, for example, be Channel 0, which is accomplished by writing to the Channel 0 Generator Selection (EVSYS.CHANNEL0) register.
4. Configure the ADC to listen to this channel by writing to the corresponding User x Channel MUX (EVSYS.USERx) register.

### 15.3.2 Operation

#### 15.3.2.1 Event User Multiplexer Setup

Each event user has one dedicated event user multiplexer selecting which event channel to listen to. The application configures these multiplexers by writing to the corresponding EVSYS.USERx register.



### 15.3.2.2 Event System Channel

An event channel can be connected to one of the event generators.

The source for each event channel is configured by writing to the respective Channel n Generator Selection (EVSYS.CHANNELn) register.

### 15.3.2.3 Event Generators

Each event channel has several possible event generators, but only one can be selected at a time. The event generator for a channel is selected by writing to the respective Channel n Generator Selection (EVSYS.CHANNELn) register. By default, the channels are not connected to any event generator. For details on event generation, refer to the documentation of the corresponding peripheral.

A generated event is either synchronous or asynchronous to the device peripheral clock (CLK\_PER). Asynchronous events can be generated outside the normal edges of the peripheral clock, making the system respond faster than the selected clock frequency would suggest. Asynchronous events can also be generated while the device is in a sleep mode when the peripheral clock is not running.

Any generated event is classified as either a pulse event or a level event. In both cases, the event can be either synchronous or asynchronous, with properties according to the table below.

**Table 15-1. Properties of Generated Events**

Event Type	Sync/Async	Description
Pulse	Sync	An event generated from CLK_PER that lasts one clock cycle
	Async	An event generated from a clock other than CLK_PER lasting one clock cycle
Level	Sync	An event generated from CLK_PER that lasts multiple clock cycles
	Async	An event generated without a clock (for example, a pin or a comparator), or an event generated from a clock other than CLK_PER that lasts multiple clock cycles

The properties of both the generated event and the intended event user must be considered in order to ensure reliable and predictable operation.

The table below shows the available event generators for this device family.

Generator Name		Description	Event Type	Generating Clock Domain	Length of event
Peripheral	Event				
UPDI	SYNCH	SYNCH character	Level	CLK_PDI	SYNCH character on PDI RX input synchronized to CLK_PDI

# AVR128DA28/32/48/64

## EVSYS - Event System

.....continued

Generator Name		Description	Event Type	Generating Clock Domain	Length of event
Peripheral	Event				
RTC	OVF	Overflow	Pulse	CLK_RTC	One CLK_RTC period
	CMP	Compare Match			
	PIT_DIV8192	Prescaled RTC clock divided by 8192	Level		Given by prescaled RTC clock divided by 8192
	PIT_DIV4096	Prescaled RTC clock divided by 4096			Given by prescaled RTC clock divided by 4096
	PIT_DIV2048	Prescaled RTC clock divided by 2048			Given by prescaled RTC clock divided by 2048
	PIT_DIV1024	Prescaled RTC clock divided by 1024			Given by prescaled RTC clock divided by 1024
	PIT_DIV512	Prescaled RTC clock divided by 512			Given by prescaled RTC clock divided by 512
	PIT_DIV256	Prescaled RTC clock divided by 256			Given by prescaled RTC clock divided by 256
	PIT_DIV128	Prescaled RTC clock divided by 128			Given by prescaled RTC clock divided by 128
	PIT_DIV64	Prescaled RTC clock divided by 64			Given by prescaled RTC clock divided by 64
CCL	LUTn	LUT output level	Level	Asynchronous	Depends on CCL configuration
ACn	OUT	Comparator output level	Level	Asynchronous	Given by AC output level
ADCn	RESRDY	Result ready	Pulse	CLK_PER	One CLK_PER period
PTC	RESRDY	Result ready	Pulse	CLK_PER	One CLK_PER period
ZCDn	OUT	ZCD output level	Level	Asynchronous	Given by ZCD output level
PORTx	PINn	Pin level	Level	Asynchronous	Given by pin level
USARTn	XCK	USART Baud clock	Level	CLK_PER	Minimum two CLK_PER periods
SPIn	SCK	SPI Master clock	Level	CLK_PER	Minimum two CLK_PER periods

.....continued

Generator Name		Description	Event Type	Generating Clock Domain	Length of event
Peripheral	Event				
TCAn	OVF_LUNF	Overflow/Low byte timer underflow	Pulse	CLK_PER	One CLK_PER period
	HUNF	High byte timer underflow			
	CMP0_LCMP0	Compare channel 0 match/Low byte timer compare channel 0 match			
	CMP1_LCMP1	Compare channel 1 match/Low byte timer compare channel 1 match			
	CMP2_LCMP2	Compare channel 2 match/Low byte timer compare channel 2 match			
TCBn	CAPT	CAPT flag set	Pulse	CLK_PER	One CLK_PER period
	OVF	Overflow			
TCDn	CMPBCLR	Counter matches CMPBCLR	Pulse	CLK_TCD	One CLK_TCD period
	CMPASET	Counter matches CMPASET			
	CMPBSET	Counter matches CMPBSET			
	PROGEV	Programmable event output			

**15.3.2.4 Event Users**

The event channel to listen to is selected by configuring the event user. An event user may require the event signal to be either synchronous or asynchronous to the peripheral clock. An asynchronous event user can respond to events in sleep modes when clocks are not running. Such events can be responded to outside the normal edges of the peripheral clock, making the event user respond faster than the clock frequency would suggest. For details on the requirements of each peripheral, refer to the documentation of the corresponding peripheral.

Most event users implement edge or level detection to trigger actions in the corresponding peripheral based on the incoming event signal. In both cases, a user can either be synchronous, which requires that the incoming event is generated from the peripheral clock (CLK\_PER), or asynchronous, if not. Some asynchronous event users do not apply event input detection but use the event signal directly. The different event user properties are described in general in the table below.

**Table 15-2. Properties of Event Users**

Input Detection	Async/Sync	Description
Edge	Sync	An event user is triggered by an event edge and requires that the incoming event is generated from CLK_PER
	Async	An event user is triggered by an event edge and has asynchronous detection or an internal synchronizer
Level	Sync	An event user is triggered by an event level and requires that the incoming event is generated from CLK_PER
	Async	An event user is triggered by an event level and has asynchronous detection or an internal synchronizer
No detection	Async	An event user will use the event signal directly

The table below shows the available event users for this device family.

USER Name		Description	Input Detection	Async/Sync
Peripheral	Input			
CCL	LUTn <sub>x</sub>	LUTn input x or clock signal	No detection	Async
ADC <sub>n</sub>	START	ADC start on event	Edge	Async
PTC	START	PTC start on event	Edge	Async
EVSYS	EVOUT <sub>x</sub>	Forward event signal to pin	No detection	Async
USART <sub>n</sub>	IRDA	IrDA mode input	Level	Sync
TCA <sub>n</sub>	CNTA	Count on positive event edge	Edge	Sync
		Count on any event edge	Edge	
		Count while event signal is high	Level	
		Event level controls count direction	Level	
	CNTB	Event level controls count direction	Level	Sync
		Restart counter on positive event edge	Edge	
		Restart counter on any event edge	Edge	
		Restart counter while event signal is high	Level	
TCB <sub>n</sub>	CAPT	Time-out check	Edge	Sync
		Input capture on event	Edge	
		Input capture frequency measurement	Edge	
		Input capture pulse-width measurement	Edge	
		Input capture frequency and pulse-width measurement	Edge	
	Single-shot	Edge	Both	
	COUNT	Count on event	Edge	Sync
TCD <sub>n</sub>	INPUTA	Fault or capture	Level or edge	Async
	INPUTB			

### 15.3.2.5 Synchronization

Events can be either synchronous or asynchronous to the peripheral clock. Each Event System channel has two subchannels: one asynchronous and one synchronous.

The asynchronous subchannel is identical to the event output from the generator. If the event generator generates a signal asynchronous to the peripheral clock, the signal on the asynchronous subchannel will be asynchronous. If the event generator generates a signal synchronous to the peripheral clock, the signal on the asynchronous subchannel will also be synchronous.

The synchronous subchannel is identical to the event output from the generator, if the event generator generates a signal synchronous to the peripheral clock. If the event generator generates a signal asynchronous to the peripheral clock, this signal is first synchronized before being routed onto the synchronous subchannel. Depending on when it occurs, synchronization will delay the event by two to three clock cycles. The Event System automatically performs this synchronization if an asynchronous generator is selected for an event channel.

### 15.3.2.6 Software Event

The application can generate a software event. Software events on Channel n are issued by writing a '1' to the Software Event Channel Select (CHANNEL[n]) bit in the Software Events (EVSYS.SWEVENT<sub>x</sub>) register. A software event appears as a pulse on the Event System channel, inverting the current event signal for one clock cycle.

Event users see software events as no different from those produced by event generating peripherals.

### **15.3.3 Sleep Mode Operation**

When configured, the Event System will work in all sleep modes. Software events represent one exception since they require a peripheral clock.

Asynchronous event users are able to respond to an event without their clock running in Standby sleep mode. Synchronous event users require their clock to be running to be able to respond to events. Such users will only work in Idle sleep mode or in Standby sleep mode, if configured to run in Standby mode by setting the RUNSTDBY bit in the appropriate register.

Asynchronous event generators are able to generate an event without their clock running, that is, in Standby sleep mode. Synchronous event generators require their clock to be running to be able to generate events. Such generators will only work in Idle sleep mode or in Standby sleep mode, if configured to run in Standby mode by setting the RUNSTDBY bit in the appropriate register.

### **15.3.4 Debug Operation**

This peripheral is unaffected by entering Debug mode.

## 15.4 Register Summary

Offset	Name	Bit Pos.	7	6	5	4	3	2	1	0
0x00	<a href="#">SWEVENTA</a>	7:0	SWEVENTA[7:0]							
0x01	<a href="#">SWEVENTB</a>	7:0	SWEVENTB[7:0]							
0x02	Reserved									
...										
0x0F										
0x10		<a href="#">CHANNEL0</a>	7:0	CHANNEL0[7:0]						
0x11	<a href="#">CHANNEL1</a>	7:0	CHANNEL1[7:0]							
0x12	<a href="#">CHANNEL2</a>	7:0	CHANNEL2[7:0]							
0x13	<a href="#">CHANNEL3</a>	7:0	CHANNEL3[7:0]							
0x14	<a href="#">CHANNEL4</a>	7:0	CHANNEL4[7:0]							
0x15	<a href="#">CHANNEL5</a>	7:0	CHANNEL5[7:0]							
0x16	<a href="#">CHANNEL6</a>	7:0	CHANNEL6[7:0]							
0x17	<a href="#">CHANNEL7</a>	7:0	CHANNEL7[7:0]							
0x18	<a href="#">CHANNEL8</a>	7:0	CHANNEL8[7:0]							
0x19	<a href="#">CHANNEL9</a>	7:0	CHANNEL9[7:0]							
0x1A	Reserved									
...										
0x1F										
0x20	<a href="#">USERCCLLUT0A</a>	7:0	USER[7:0]							
...										
0x4A	<a href="#">USERTCD0INPUTB</a>	7:0	USER[7:0]							

## 15.5 Register Description

### 15.5.1 Software Events

**Name:** SWEVENTx  
**Offset:** 0x00 + x\*0x01 [x=0..1]  
**Reset:** 0x00  
**Property:** -

Write bits in this register to create a software event on the corresponding event channels.

Bits 0-7 in the EVSYS.SWEVENTA register correspond to event channels 0-7. If the number of available event channels is between eight and 15, these are available in the EVSYS.SWEVENTB register, where bit n corresponds to event channel 8+n.

Refer to the *Peripheral Overview* section for the available number of Event System channels.

Bit	7	6	5	4	3	2	1	0
	SWEVENTx[7:0]							
Access	W	W	W	W	W	W	W	W
Reset	0	0	0	0	0	0	0	0

#### Bits 7:0 – SWEVENTx[7:0] Software Event Channel Select

Writing a bit in this bit group to '1' will generate a single-pulse event on the corresponding event channel by inverting the signal on the event channel for one peripheral clock cycle.

### 15.5.2 Channel n Generator Selection

**Name:** CHANNELn  
**Offset:** 0x10 + n\*0x01 [n=0..9]  
**Reset:** 0x00  
**Property:** -

Each channel can be connected to one event generator. Not all generators can be connected to all channels. Refer to the table below to see which generator sources can be routed onto each channel and the generator value to be written to EVSYS.CHANNELn to achieve this routing. Writing the value 0x00 to EVSYS.CHANNELn turns the channel off.

Bit	7	6	5	4	3	2	1	0
	CHANNELn[7:0]							
Access	R/W	R/W	R/W	R/W	R/W	R/W	R/W	R/W
Reset	0	0	0	0	0	0	0	0

#### Bits 7:0 – CHANNELn[7:0] Channel Generator Selection

The specific generator name corresponding to each bit group configuration is given by combining Peripheral and Output from the table below in the following way: PERIPHERAL\_OUTPUT.

GENERATOR			Async/Sync	Description	Channel Availability
Value	Name				
	Peripheral	Output			
0x01	UPDI	SYNCH	Sync	Rising edge of SYNCH character detection	All channels
0x06	RTC	OVF	Async	Counter overflow	All channels
0x07		CMP		Compare match	
0x08		PIT_DIV8192		Prescaled RTC clock divided by 8192	
0x09		PIT_DIV4096		Prescaled RTC clock divided by 4096	
0x0A		PIT_DIV2048		Prescaled RTC clock divided by 2048	
0x0B		PIT_DIV1024		Prescaled RTC clock divided by 1024	
0x08		PIT_DIV512		Prescaled RTC clock divided by 512	
0x09		PIT_DIV256		Prescaled RTC clock divided by 256	
0x0A		PIT_DIV128		Prescaled RTC clock divided by 128	
0x0B		PIT_DIV64		Prescaled RTC clock divided by 64	
0x10	CCL	LUT0	Async	LUT output level	All channels
0x11		LUT1			
0x12		LUT2			
0x13		LUT3			
0x14		LUT4 <sup>(1)</sup>			
0x15		LUT5 <sup>(1)</sup>			
0x20	AC0	OUT	Async	Comparator output level	All channels
0x21	AC1				
0x22	AC2				
0x24	ADC0	RESRDY	Sync	Result ready	All channels
0x28	PTC	RESRDY	Sync	Result ready	All channels
0x30	ZCD0	OUT	Async	ZCD output level	All channels
0x31	ZCD1 <sup>(1)</sup>				
0x32	ZCD2 <sup>(1)</sup>				
0x40-0x47	PORTA	PIN0-PIN7	Async	Pin level <sup>(2)</sup>	CHANNEL0 and CHANNEL1 only
0x48-0x4F	PORTB <sup>(1)</sup>				
0x40-0x47	PORTC	PIN0-PIN7	Async	PIN level <sup>(2)</sup>	CHANNEL2 and CHANNEL3 only
0x48-0x4F	PORTD				
0x40-0x47	PORTE <sup>(1)</sup>	PIN0-PIN7	Async	Pin level <sup>(2)</sup>	CHANNEL4 and CHANNEL5 only
0x48-0x4F	PORTF				
0x40-0x47	PORTG <sup>(1)</sup>	PIN0-PIN7	Async	Pin level <sup>(2)</sup>	CHANNEL6 and CHANNEL7 only
0x60	USART0	XCK	Sync	Clock signal in SPI Master mode and synchronous USART Master mode	All channels
0x61	USART1				
0x62	USART2				
0x63	USART3 <sup>(1)</sup>				
0x64	USART4 <sup>(1)</sup>				
0x65	USART5 <sup>(1)</sup>				



.....continued

GENERATOR		Async/Sync	Description	Channel Availability	
Value	Name				
	Peripheral	Output			
0x68	SPI0	SCK	Sync	SPI master clock signal	All channels
0x69	SPI1				
0x80	TCA0	OVF_LUNF	Sync	Overflow/Low byte timer underflow	All channels
0x81		HUNF	Sync	High byte timer underflow	
0x84		CMP0_LCMP0	Sync	Compare channel 0 match/Low byte timer compare channel 0 match	
0x85		CMP1_LCMP1	Sync	Compare channel 1 match/Low byte timer compare channel 1 match	
0x86		CMP2_LCMP2	Sync	Compare channel 2 match/Low byte timer compare channel 2 match	
0x88	TCA1 <sup>(1)</sup>	OVF_LUNF	Sync	Overflow/Low byte timer underflow	All channels
0x89		HUNF		High byte timer underflow	
0x8C		CMP0_LCMP0		Compare channel 0 match/Low byte timer compare channel 0 match	
0x8D		CMP1_LCMP1		Compare channel 1 match/Low byte timer compare channel 1 match	
0x8E		CMP2_LCMP2		Compare channel 2 match/Low byte timer compare channel 2 match	
0xA0	TCB0	CAPT	Sync	CAPT Interrupt flag set <sup>(3)</sup>	All channels
0xA1		OVF		Counter overflow	
0xA2	TCB1	CAPT	Sync	CAPT Interrupt flag set <sup>(3)</sup>	All channels
0xA3		OVF		Counter overflow	
0xA4	TCB2	CAPT	Sync	CAPT interrupt flag set <sup>(3)</sup>	All channels
0xA5		OVF		Counter overflow	
0xA6	TCB3 <sup>(1)</sup>	CAPT	Sync	CAPT interrupt flag set <sup>(3)</sup>	All channels
0xA7		OVF		Counter overflow	
0xA8	TCB4 <sup>(1)</sup>	CAPT	Sync	CAPT interrupt flag set <sup>(3)</sup>	All channels
0xA9		OVF		Counter overflow	
0xB0	TCD0	CMPBCLR	Async	Counter matches CMPBCLR	All channels
0xB1		CMPASET		Counter matches CMPASET	
0xB2		CMPBSET		Counter matches CMPBSET	
0xB3		PROGEV		Programmable event output	

**Notes:**

1. Not all peripheral instances are available for all pin counts. Refer to the *Peripherals and Architecture* section for details.
2. Event from PORT pin will be zero if the input driver is disabled.
3. The operational mode of the timer decides when the CAPT flag is raised. See the *16-bit Timer/Counter Type B (TCB)* section for details.

### 15.5.3 User Channel MUX

**Name:** USER  
**Offset:** 0x20 + n\*0x01 [n=0..42]  
**Reset:** 0x00  
**Property:** -

Each event user can be connected to one channel and several users can be connected to the same channel. The following table lists all Event System users with their corresponding user ID number and name. The user name is given by combining USER with Peripheral and Input from the table below in the following way: USERPERIPHERALINPUT.

USER #	User Name		Async/ Sync	Description
	Module	Input		
0x00	CCL	LUT0A	Async	CCL LUT0 event input A
0x01		LUT0B		CCL LUT0 event input B
0x02		LUT1A		CCL LUT1 event input A
0x03		LUT1B		CCL LUT1 event input B
0x04		LUT2A		CCL LUT2 event input A
0x05		LUT2B		CCL LUT2 event input B
0x06		LUT3A		CCL LUT3 event input A
0x07		LUT3B		CCL LUT3 event input B
0x08		LUT4A <sup>(1)</sup>		CCL LUT4 event input A
0x09		LUT4B <sup>(1)</sup>		CCL LUT4 event input B
0x0A		LUT5A <sup>(1)</sup>		CCL LUT5 event input A
0x0B		LUT5B <sup>(1)</sup>		CCL LUT5 event input B
0x0C		ADC0		START
0x0D	PTC	START	Async	PTC start on event
0x0E	EVSYS	EVOUTA	Async	EVSYS pin output A
0x0F		EVOUTB <sup>(1)</sup>		Event output B
0x10		EVOUTC		Event output C
0x11		EVOUTD		Event output D
0x12		EVOUTE <sup>(1)</sup>		Event output E
0x13		EVOUTF <sup>(1)</sup>		Event output F
0x14		EVOUTG <sup>(1)</sup>		Event output G
0x15	USART0	IRDA	Sync	USART0 IrDA event input
0x16	USART1	IRDA		USART1 IrDA event input
0x17	USART2	IRDA		USART2 IrDA event input
0x18	USART3	IRDA		USART3 IrDA event input
0x19	USART4	IRDA		USART4 IrDA event input
0x1A	USART5	IRDA		USART5 IrDA event input

.....continued

USER #	User Name		Async/ Sync	Description
	Module	Input		
0x1B	TCA0	CNTA	Sync	Count on event or control count direction
0x1C		CNTB		Restart on event or control count direction
0x1D	TCA1 <sup>(1)</sup>	CNTA	Sync	Count on event or control count direction
0x1E		CNTB		Restart on event or control count direction
0x1F	TCB0	CAPT	Both <sup>(2)</sup>	Start, stop, capture, restart or clear counter
0x20		COUNT	Sync	Count on event
0x21	TCB1	CAPT	Both <sup>(2)</sup>	Start, stop, capture, restart or clear counter
0x22		COUNT	Sync	Count on event
0x23	TCB2	CAPT	Both <sup>(2)</sup>	Start, stop, capture, restart or clear counter
0x24		COUNT	Sync	Count on event
0x25	TCB3 <sup>(1)</sup>	CAPT	Both <sup>(2)</sup>	Start, stop, capture, restart or clear counter
0x26		COUNT	Sync	Count on event
0x27	TCB4 <sup>(1)</sup>	CAPT	Both <sup>(2)</sup>	Start, stop, capture, restart or clear counter
0x28		COUNT	Sync	Count on event
0x29	TCD0	INPUTA	Async	Fault or capture
0x2A		INPUTB		Fault or capture

**Notes:**

1. Not all peripheral instances are available for all pin counts. Refer to the *Peripherals and Architecture* section for details.
2. Depends on the timer operational mode.

Bit	7	6	5	4	3	2	1	0
	USER[7:0]							
Access	R/W	R/W	R/W	R/W	R/W	R/W	R/W	R/W
Reset	0	0	0	0	0	0	0	0

**Bits 7:0 – USER[7:0]** User Channel Selection

Configures which Event System channel the user is connected to.

Value	Description
0	OFF, no channel is connected to this Event System user
n	The event user is connected to CHANNEL(n-1)

## **16. PORTMUX - Port Multiplexer**

### **16.1 Overview**

The Port Multiplexer (PORTMUX) can either enable or disable the functionality of the pins, or change between default and alternative pin positions. Available options are described in detail in the PORTMUX register map and depend on the actual pin and its properties.

For available pins and functionality, refer to the *I/O Multiplexing and Considerations* section.

## 16.2 Register Summary

Offset	Name	Bit Pos.	7	6	5	4	3	2	1	0
0x00	<a href="#">EVSYSROUTEA</a>	7:0		EVOUTG	EVOUTF	EVOUTE	EVOUTD	EVOUTC	EVOUTB	EVOUTA
0x01	<a href="#">CCLROUTEA</a>	7:0			LUT5	LUT4	LUT3	LUT2	LUT1	LUT0
0x02	<a href="#">USARROUTEA</a>	7:0	USART3[1:0]		USART2[1:0]		USART1[1:0]		USART0[1:0]	
0x03	<a href="#">USARROUTEA</a>	7:0					USART5[1:0]		USART4[1:0]	
0x04	<a href="#">SPIROUTEA</a>	7:0					SPI1[1:0]		SPI0[1:0]	
0x05	<a href="#">TWIRROUTEA</a>	7:0					TWI1[1:0]		TWI0[1:0]	
0x06	<a href="#">TCARROUTEA</a>	7:0			TCA1[2:0]			TCA0[2:0]		
0x07	<a href="#">TCBROUTEA</a>	7:0				TCB4	TCB3	TCB2	TCB1	TCB0
0x08	<a href="#">TCDROUTEA</a>	7:0						TCD0[2:0]		
0x09	<a href="#">ACROUTEA</a>	7:0						AC2	AC1	AC0
0x0A	<a href="#">ZCDROUTEA</a>	7:0						ZCD2	ZCD1	ZCD0

## 16.3 Register Description

### 16.3.1 EVSYS Pin Position

**Name:** EVSYSROUTEA  
**Offset:** 0x00  
**Reset:** 0x00  
**Property:** -

Bit	7	6	5	4	3	2	1	0
		EVOUTG	EVOUTF	EVOUTE	EVOUTD	EVOUTC	EVOUTB	EVOUTA
Access		R/W	R/W	R/W	R/W	R/W	R/W	R/W
Reset		0	0	0	0	0	0	0

#### Bit 6 – EVOUTG Event Output G

This bit controls the pin position for event output G.

Value	Name	Description
0x0	DEFAULT	EVOUT on PG2
0x1	ALT1	EVOUT on PG7

#### Bit 5 – EVOUTF Event Output F

This bit controls the pin position for event output F.

Value	Name	Description
0x0	DEFAULT	EVOUT on PF2
0x1	ALT1	-

#### Bit 4 – EVOUTE Event Output E

This bit controls the pin position for event output E.

Value	Name	Description
0x0	DEFAULT	EVOUT on PE2
0x1	ALT1	EVOUT on PE7

#### Bit 3 – EVOUTD Event Output D

This bit controls the pin position for event output D.

Value	Name	Description
0x0	DEFAULT	EVOUT on PD2
0x1	ALT1	EVOUT on PD7

#### Bit 2 – EVOUTC Event Output C

This bit controls the pin position for event output C.

Value	Name	Description
0x0	DEFAULT	EVOUT on PC2
0x1	ALT1	EVOUT on PC7

#### Bit 1 – EVOUTB Event Output B

This bit controls the pin position for event output B.

Value	Name	Description
0x0	DEFAULT	EVOUT on PB2
0x1	ALT1	EVOUT on PB7

#### Bit 0 – EVOUTA Event Output A

This bit controls the pin position for event output A.

**AVR128DA28/32/48/64**  
**PORTMUX - Port Multiplexer**

Value	Name	Description
0x0	DEFAULT	EVOUT on PA2
0x1	ALT1	EVOUT on PA7

### 16.3.2 CCL LUTn Pin Position

**Name:** CCLROUTEA  
**Offset:** 0x01  
**Reset:** 0x00  
**Property:** -

	7	6	5	4	3	2	1	0
Access			LUT5	LUT4	LUT3	LUT2	LUT1	LUT0
Reset			R/W	R/W	R/W	R/W	R/W	R/W
			0	0	0	0	0	0

#### Bit 5 – LUT5 CCL LUT 5 Signals

This bit field controls the pin positions for CCL LUT 5 signals.

Value	Name	Description			
		OUT	IN0	IN1	IN2
0x0	DEFAULT	PG3	PG0	PG1	PG2
0x1	ALT1	PG6	PG0	PG1	PG2

#### Bit 4 – LUT4 CCL LUT 4 Signals

This bit field controls the pin positions for CCL LUT 4 signals.

Value	Name	Description			
		OUT	IN0	IN1	IN2
0x0	DEFAULT	PB3	PB0	PB1	PB2
0x1	ALT1	PB6	PB0	PB1	PB2

#### Bit 3 – LUT3 CCL LUT 3 Signals

This bit field controls the pin positions for CCL LUT 3 signals.

Value	Name	Description			
		OUT	IN0	IN1	IN2
0x0	DEFAULT	PF3	PF0	PF1	PF2
0x1	-	-	-	-	-

#### Bit 2 – LUT2 CCL LUT 2 Signals

This bit field controls the pin positions for CCL LUT 2 signals.

Value	Name	Description			
		OUT	IN0	IN1	IN2
0x0	DEFAULT	PD3	PD0	PD1	PD2
0x1	ALT1	PD6	PD0	PD1	PD2

#### Bit 1 – LUT1 CCL LUT 1 Signals

This bit field controls the pin positions for CCL LUT 1 signals.

Value	Name	Description			
		OUT	IN0	IN1	IN2
0x0	DEFAULT	PC3	PC0	PC1	PC2
0x1	ALT1	PC6	PC0	PC1	PC2



**Bit 0 – LUT0** CCL LUT 0 Signals

This bit field controls the pin positions for CCL LUT 0 signals.

Value	Name	Description			
		OUT	IN0	IN1	IN2
0x0	DEFAULT	PA3	PA0	PA1	PA2
0x1	ALT1	PA6	PA0	PA1	PA2

### 16.3.3 USARTn Pin Position

**Name:** USARTROUTEA  
**Offset:** 0x02  
**Reset:** 0x00  
**Property:** -

Bit	7	6	5	4	3	2	1	0
	USART3[1:0]		USART2[1:0]		USART1[1:0]		USART0[1:0]	
Access	R/W	R/W	R/W	R/W	R/W	R/W	R/W	R/W
Reset	0	0	0	0	0	0	0	0

#### Bits 7:6 – USART3[1:0] USART 3 Signals

This bit field controls the pin positions for USART 3 signals.

Value	Name	Description			
		TxD	RxD	XCK	XDIR
0x0	DEFAULT	PB0	PB1	PB2	PB3
0x1	ALT1	PB4	PB5	PB6	PB7
0x2	-	Reserved			
0x3	NONE	Not connected to any pins			

#### Bits 5:4 – USART2[1:0] USART 2 Signals

This bit field controls the pin positions for USART 2 signals.

Value	Name	Description			
		TxD	RxD	XCK	XDIR
0x0	DEFAULT	PF0	PF1	PF2	PF3
0x1	ALT1	PF4	PF5	-	-
0x2	-	Reserved			
0x3	NONE	Not connected to any pins			

#### Bits 3:2 – USART1[1:0] USART 1 Signals

This bit field controls the pin positions for USART 1 signals.

Value	Name	Description			
		TxD	RxD	XCK	XDIR
0x0	DEFAULT	PC0	PC1	PC2	PC3
0x1	ALT1	PC4	PC5	PC6	PC7
0x2	-	Reserved			
0x3	NONE	Not connected to any pins			

#### Bits 1:0 – USART0[1:0] USART 0 Signals

This bit field controls the pin positions for USART 0 signals.

Value	Name	Description			
		TxD	RxD	XCK	XDIR
0x0	DEFAULT	PA0	PA1	PA2	PA3
0x1	ALT1	PA4	PA5	PA6	PA7
0x2	-	Reserved			
0x3	NONE	Not connected to any pins			

### 16.3.4 USARTn Pin Position

**Name:** USARTROUTEB  
**Offset:** 0x03  
**Reset:** 0x00  
**Property:** -

	7	6	5	4	3	2	1	0
					USART5[1:0]		USART4[1:0]	
Access					R/W	R/W	R/W	R/W
Reset					0	0	0	0

#### Bits 3:2 – USART5[1:0] USART 5 Signals

This bit field controls the pin positions for USART 5 signals.

Value	Name	Description			
		TxD	RxD	XCK	XDIR
0x0	DEFAULT	PG0	PG1	PG2	PG3
0x1	ALT1	PG4	PG5	PG6	PG7
0x2	-	Reserved			
0x3	NONE	Not connected to any pins			

#### Bits 1:0 – USART4[1:0] USART 4 Signals

This bit field controls the pin positions for USART 4 signals.

Value	Name	Description			
		TxD	RxD	XCK	XDIR
0x0	DEFAULT	PE0	PE1	PE2	PE3
0x1	ALT1	PE4	PE5	PE6	PE7
0x2	-	Reserved			
0x3	NONE	Not connected to any pins			

## 16.3.5 SPIn Pin Position

**Name:** SPIROUTEA  
**Offset:** 0x04  
**Reset:** 0x00  
**Property:** -

Bit	7	6	5	4	3	2	1	0
					SPI1[1:0]		SPI0[1:0]	
Access					R/W	R/W	R/W	R/W
Reset					0	0	0	0

**Bits 3:2 – SPI1[1:0]** SPI 1 Signals

This bit field controls the pin positions for SPI 1 signals.

Value	Name	Description			
		MOSI	MISO	SCK	$\overline{SS}$
0x0	DEFAULT	PC0	PC1	PC2	PC3
0x1	ALT1	PC4	PC5	PC6	PC7
0x2	ALT2	PB4	PB5	PB6	PB7
0x3	NONE	Not connected to any pins			

**Bits 1:0 – SPI0[1:0]** SPI 0 Signals

This bit field controls the pin positions for SPI 0 signals.

Value	Name	Description			
		MOSI	MISO	SCK	$\overline{SS}$
0x0	DEFAULT	PA4	PA5	PA6	PA7
0x1	ALT1	PE0	PE1	PE2	PE3
0x2	ALT2	PG4	PG5	PG6	PG7
0x3	NONE	Not connected to any pins			

### 16.3.6 TWIn Pin Position

**Name:** TWIROUTEA  
**Offset:** 0x05  
**Reset:** 0x00  
**Property:** -

Bit	7	6	5	4	3	2	1	0
					TWI1[1:0]		TWI0[1:0]	
Access					R/W	R/W	R/W	R/W
Reset					0	0	0	0

#### Bits 3:2 – TWI1[1:0] TWI 1 Signals

This bit field controls the pin positions for TWI 1 signals.

Value	Name	Description			
		Master/Slave		Dual mode (Slave)	
		SDA	SCL	SDA	SCL
0x0	DEFAULT	PF2	PF3	PB2	PB3
0x1	ALT1	PF2	PF3	PB6	PB7
0x2	ALT2	PB2	PB3	PB6	PB7
0x3	-	Reserved			

#### Bits 1:0 – TWI0[1:0] TWI 0 Signals

This bit field controls the pin positions for TWI 0 signals.

Value	Name	Description			
		Master/Slave		Dual mode (Slave)	
		SDA	SCL	SDA	SCL
0x0	DEFAULT	PA2	PA3	PC2	PC3
0x1	ALT1	PA2	PA3	PC6	PC7
0x2	ALT2	PC2	PC3	PC6	PC7
0x3	-	Reserved			

### 16.3.7 TCAn Pin Position

**Name:** TCAROUTEA  
**Offset:** 0x06  
**Reset:** 0x00  
**Property:** -

Bit	7	6	5	4	3	2	1	0
			TCA1[2:0]			TCA0[2:0]		
Access			R/W	R/W	R/W	R/W	R/W	R/W
Reset			0	0	0	0	0	0

#### Bits 5:3 – TCA1[2:0] TCA1 Signals

This bit field controls the pin positions for TCA1 signals.

Value	Name	Description					
		WO0	WO1	WO2	WO3	WO4	WO5
0x0	PORTB	PB0	PB1	PB2	PB3	PB4	PB5
0x1	PORTC	PC4	PC5	PC6	-	-	-
0x2	PORTE	PE4	PE5	PE6	-	-	-
0x3	PORTG	PG0	PG1	PG2	PG3	PG4	PG5
Other	-	Reserved					

#### Bits 2:0 – TCA0[2:0] TCA0 Signals

This bit field controls the pin positions for TCA0 signals.

Value	Name	Description					
		WO0	WO1	WO2	WO3	WO4	WO5
0x0	PORTA	PA0	PA1	PA2	PA3	PA4	PA5
0x1	PORTB	PB0	PB1	PB2	PB3	PB4	PB5
0x2	PORTC	PC0	PC1	PC2	PC3	PC4	PC5
0x3	PORTD	PD0	PD1	PD2	PD3	PD4	PD5
0x4	PORTE	PE0	PE1	PE2	PE3	PE4	PE5
0x5	PORTF	PF0	PF1	PF2	PF3	PF4	PF5
0x6	PORTG	PG0	PG1	PG2	PG3	PG4	PG5
0x7	-	Reserved					

### 16.3.8 TCBn Pin Position

**Name:** TCBROUTEA  
**Offset:** 0x07  
**Reset:** 0x00  
**Property:** -

Bit	7	6	5	4	3	2	1	0
				TCB4	TCB3	TCB2	TCB1	TCB0
Access				R/W	R/W	R/W	R/W	R/W
Reset				0	0	0	0	0

#### Bit 4 – TCB4 TCB4 Output

This bit controls the pin position for TCB4 output.

Value	Name	Description
0x0	DEFAULT	WO on PG3
0x1	ALT1	WO on PC6

#### Bit 3 – TCB3 TCB3 Output

This bit controls the pin position for TCB3 output.

Value	Name	Description
0x0	DEFAULT	WO on PB5
0x1	ALT1	WO on PC1

#### Bit 2 – TCB2 TCB2 Output

This bit controls the pin position for TCB2 output.

Value	Name	Description
0x0	DEFAULT	WO on PC0
0x1	ALT1	WO on PB4

#### Bit 1 – TCB1 TCB1 Output

This bit controls the pin position for TCB1 output.

Value	Name	Description
0x0	DEFAULT	WO on PA3
0x1	ALT1	WO on PF5

#### Bit 0 – TCB0 TCB0 Output

This bit controls the pin position for TCB0 output.

Value	Name	Description
0x0	DEFAULT	WO on PA2
0x1	ALT1	WO on PF4

## 16.3.9 TCDn Pin Position

**Name:** TCDROUTEA  
**Offset:** 0x08  
**Reset:** 0x00  
**Property:** -

Bit	7	6	5	4	3	2	1	0
						TCD0[2:0]		
Access						R/W	R/W	R/W
Reset						0	0	0

**Bits 2:0 – TCD0[2:0]** TCD0 Signals

This bit field controls the pin positions for TCD0 signals.

Value	Name	Description			
		WOA	WOB	WOC	WOD
0x0	DEFAULT	PA4	PA5	PA6	PA7
0x1	ALT1	PB4	PB5	PB6	PB7
0x2	ALT2	PF0	PF1	PF2	PF3
0x3	ALT3	PG4	PG5	PG6	PG7
Other	-	Reserved			



### 16.3.10 ACn Pin Position

**Name:** ACROUTEA  
**Offset:** 0x09  
**Reset:** 0x00  
**Property:** -

	7	6	5	4	3	2	1	0
						AC2	AC1	AC0
Access						R/W	R/W	R/W
Reset						0	0	0

#### Bit 2 – AC2 Analog Comparator 2 Output

This bit controls the pin position for AC2 output.

Value	Name	Description
0x0	DEFAULT	OUT on PA7
0x1	ALT1	OUT on PC6

#### Bit 1 – AC1 Analog comparator 1 Output

This bit controls the pin position for AC1 output.

Value	Name	Description
0x0	DEFAULT	OUT on PA7
0x1	ALT1	OUT on PC6

#### Bit 0 – AC0 Analog Comparator 0 Output

This bit controls the pin position for AC0 output.

Value	Name	Description
0x0	DEFAULT	OUT on PA7
0x1	ALT1	OUT on PC6

### 16.3.11 ZCDn Pin Position

**Name:** ZCDROUTEA  
**Offset:** 0x0A  
**Reset:** 0x00  
**Property:** -

	7	6	5	4	3	2	1	0
						ZCD2	ZCD1	ZCD0
Access						R/W	R/W	R/W
Reset						0	0	0

**Bit 2 – ZCD2** Zero-Cross Detector 2 Output  
 This bit controls the pin position for ZCD2 output.

Value	Name	Description
0x0	DEFAULT	OUT on PA7
0x1	ALT1	OUT on PC7

**Bit 1 – ZCD1** Zero-Cross Detector 1 Output  
 This bit controls the pin position for ZCD1 output.

Value	Name	Description
0x0	DEFAULT	OUT on PA7
0x1	ALT1	OUT on PC7

**Bit 0 – ZCD0** Zero-Cross Detector 0 Output  
 This bit controls the pin position for ZCD0 output.

Value	Name	Description
0x0	DEFAULT	OUT on PA7
0x1	ALT1	OUT on PC7

## 17. PORT - I/O Pin Configuration

### 17.1 Features

- General Purpose Input and Output Pins with Individual Configuration:
  - Pull-up
  - Inverted I/O
- Interrupts and Events:
  - Sense both edges
  - Sense rising edges
  - Sense falling edges
  - Sense low level
- Optional Slew Rate Control per I/O Port
- Asynchronous Pin Change Sensing that Can Wake the Device From all Sleep Modes
- Efficient and Safe Access to Port Pins
  - Hardware Read-Modify-Write (RMW) through dedicated toggle/clear/set registers
  - Mapping of often-used PORT registers into bit-accessible I/O memory space (virtual ports)

### 17.2 Overview

The I/O pins of the device are controlled by instances of the PORT peripheral registers. Each PORT instance has up to eight I/O pins. The PORTs are named PORTA, PORTB, PORTC, etc. Refer to the *I/O Multiplexing and Considerations* section to see which pins are controlled by what instance of PORT. The base addresses of the PORT instances and the corresponding Virtual PORT instances are listed in the *Peripherals and Architecture* section.

Each PORT pin has a corresponding bit in the Data Direction (PORTx.DIR) and Data Output Value (PORTx.OUT) registers to enable that pin as an output and to define the output state. For example, pin PA3 is controlled by DIR[3] and OUT[3] of the PORTA instance.

The input value of a PORT pin is synchronized to the Peripheral Clock (CLK\_PER) and then made accessible as the data input value (PORTx.IN). The value of the pin can be read whether the pin is configured as input or output.

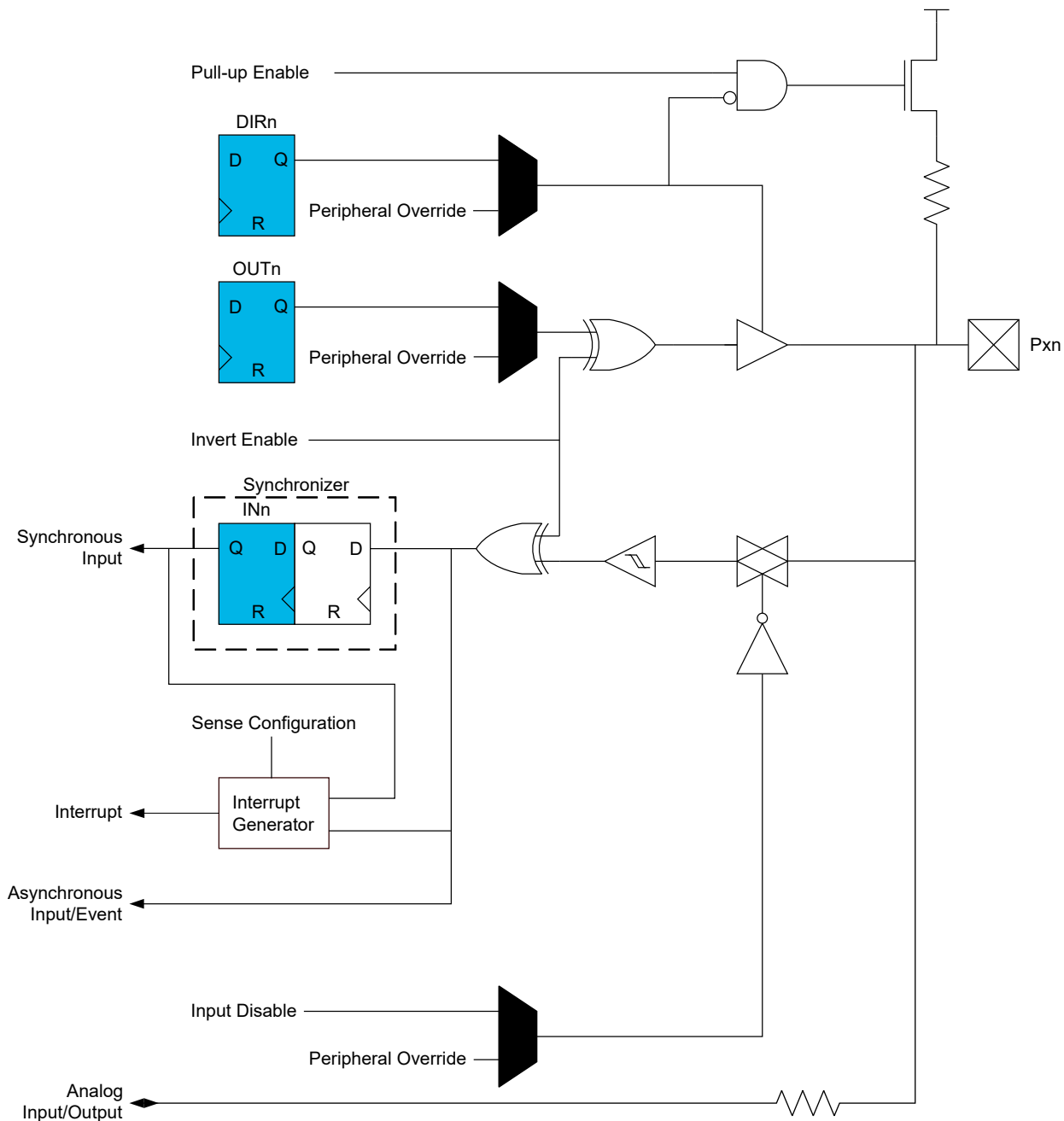
The PORT also supports asynchronous input sensing with interrupts and events for selectable pin change conditions. Asynchronous pin change sensing means that a pin change can trigger an interrupt and wake the device from sleep, including sleep modes where CLK\_PER is stopped.

All pin functions are individually configurable per pin. The pins have hardware Read-Modify-Write functionality for a safe and correct change of the drive values and/or input and sense configuration.

The PORT pin configuration controls input and output selection of other device functions.

17.2.1 Block Diagram

Figure 17-1. PORT Block Diagram



17.2.2 Signal Description

Signal	Type	Description
Pxn	I/O pin	I/O pin n on PORTx

## 17.3 Functional Description

### 17.3.1 Initialization

After Reset, all outputs are tri-stated, and digital input buffers enabled even if there is no clock running.

The following steps are all optional when initializing PORT operation:

- Enable or disable the output driver for pin P<sub>xn</sub> by respectively writing '1' to bit n in the PORTx.DIRSET or PORTx.DIRCLR register
- Set the output driver for pin P<sub>xn</sub> to high or low level respectively by writing '1' to bit n in the PORTx.OUTSET or PORTx.OUTCLR register
- Read the input of pin P<sub>xn</sub> by reading bit n in the PORTx.IN register
- Configure the individual pin configurations and interrupt control for pin P<sub>xn</sub> in PORTx.PINnCTRL



**Important:** For lowest power consumption, disable the digital input buffer of unused pins and pins that are used as analog inputs or outputs.

Specific pins, such as those used to connect a debugger, may be configured differently, as required by their special function.

### 17.3.2 Operation

#### 17.3.2.1 Basic Functions

Each pin group x has its own set of PORT registers. I/O pin P<sub>xn</sub> can be controlled by the registers in PORTx.

To use pin number n as an output, write bit n of the PORTx.DIR register to '1'. This can be done by writing bit n in the PORTx.DIRSET register to '1', which will avoid disturbing the configuration of other pins in that group. The n<sup>th</sup> bit in the PORTx.OUT register must be written to the desired output value.

Similarly, writing a PORTx.OUTSET bit to '1' will set the corresponding bit in the PORTx.OUT register to '1'. Writing a bit in PORTx.OUTCLR to '1' will clear that bit in PORTx.OUT to '0'. Writing a bit in PORTx.OUTTGL or PORTx.IN to '1' will toggle that bit in PORTx.OUT.

To use pin n as an input, bit n in the PORTx.DIR register must be written to '0' to disable the output driver. This can be done by writing bit n in the PORTx.DIRCLR register to '1', which will avoid disturbing the configuration of other pins in that group. The input value can be read from bit n in the PORTx.IN register as long as the ISC bit is not set to INPUT\_DISABLE.

Writing a bit to '1' in PORTx.DIRTGL will toggle that bit in PORTx.DIR and toggle the direction of the corresponding pin.

#### 17.3.2.2 Port Configuration

The Port Control (PORTx.PORTCTRL) register is used to configure the slew rate limitation for all the PORTx pins.

The slew rate limitation is enabled by writing a '1' to the Slew Rate Limit Enable (SLR) bit in PORTx.PORTCTRL. Refer to the *Electrical Characteristics* section for further details.

#### 17.3.2.3 Pin Configuration

The Pin n Control (PORTx.PINnCTRL) register is used to configure inverted I/O, pull-up, and input sensing of a pin. The control register for pin n is at the byte address  $PORTx + 0x10 + n$ .

All input and output on the respective pin n can be inverted by writing a '1' to the Inverted I/O Enable (INVEN) bit in PORTx.PINnCTRL. When INVEN is '1', the PORTx.IN/OUT/OUTSET/OUTTGL registers will have an inverted operation for this pin.

Toggling the INVEN bit causes an edge on the pin, which can be detected by all peripherals using this pin, and is seen by interrupts or events if enabled.

The input pull-up of pin *n* is enabled by writing a '1' to the Pull-up Enable (PULLUPEN) bit in PORTx.PINnCTRL. The pull-up is disconnected when the pin is configured as an output, even if PULLUPEN is '1'.

Pin interrupts can be enabled for pin *n* by writing to the Input/Sense Configuration (ISC) bit field in PORTx.PINnCTRL. Refer to [17.3.3 Interrupts](#) for further details.

The digital input buffer for pin *n* can be disabled by writing the INPUT\_DISABLE setting to ISC. This can reduce power consumption and may reduce noise if the pin is used as analog input. While configured to INPUT\_DISABLE, bit *n* in PORTx.IN will not change since the input synchronizer is disabled.

#### 17.3.2.4 Multi-Pin Configuration

The multi-pin configuration function is used to configure multiple PORT pins in one operation. The wanted pin configuration is first written to the PORTx.PINCONFIG register, followed by a register write, with the selected pins to modify. This allows changing the configuration (PORTx.PINnCTRL) for up to eight pins in one write.



**Tip:** The PORTx.PINCONFIG register is mirrored on all ports, which allows the use of a single setting across multiple ports. The PORTx.PINCTRLUPD/SET/CLR registers are not mirrored and need to be applied to each port.

For the multi-pin configuration, PORT pins can be configured and modified by writing to the following registers.

**Table 17-1. Multi-Pin Configuration Registers**

Register	Description
PORTx.PINCONFIG	PINnCTRL (ISC, PULLUPEN and INVEN) setting to load simultaneously to multiple PINnCTRL registers
PORTx.PINCTRLUPD	Writing a '1' to bit <i>n</i> in the PINCTRLUPD register will copy the PINCONFIG register content to the PINnCTRL register
PORTx.PINCTRLSET <sup>(1)</sup>	Writing a '1' to bit <i>n</i> in the PINCTRLSET register will set the individual bits in the PINnCTRL register, according to the bits set to '1' in the PINCONFIG register
PORTx.PINCTRLCLR <sup>(2)</sup>	Writing a '1' to bit <i>n</i> in the PINCTRLCLRn register will clear the individual bits in the PINnCTRL register, according to the bits set to '1' in the PINCONFIG register

**Notes:**

- Using PINCTRLSET to configure ISC bit fields that are non-zero will result in a bitwise OR with the PINCONFIG and PINnCTRL registers. This may give an unexpected setting.
- Using PINCTRLCLR to configure ISC bit fields that are non-zero will result in a bitwise inverse AND with the PINCONFIG and PINnCTRL registers. This may give an unexpected setting.

#### 17.3.2.5 Virtual Ports

The Virtual PORT registers map the most frequently used regular PORT registers into the I/O Register space with single-cycle bit access. Access to the Virtual PORT registers has the same outcome as access to the regular registers but allows for memory specific instructions, such as bit manipulation instructions, which cannot be used in the extended I/O Register space where the regular PORT registers reside. The following table shows the mapping between the PORT and VPORT registers.

**Table 17-2. Virtual Port Mapping**

Regular PORT Register	Mapped to Virtual PORT Register
PORTx.DIR	VPORTx.DIR
PORTx.OUT	VPORTx.OUT
PORTx.IN	VPORTx.IN
PORTx.INTFLAGS	VPORTx.INTFLAGS

### 17.3.2.6 Peripheral Override

Peripherals such as USARTs, ADCs and timers may be connected to I/O pins. Such peripherals will usually have a primary and, optionally, one or more alternate I/O pin connections, selectable by PORTMUX or a multiplexer inside the peripheral. By configuring and enabling such peripherals, the general purpose I/O pin behavior normally controlled by PORT will be overridden in a peripheral dependent way. Some peripherals may not override all the PORT registers, leaving the PORT module to control some aspects of the I/O pin operation.

Refer to the description of each peripheral for information on the peripheral override. Any pin in a PORT that is not overridden by a peripheral will continue to operate as a general purpose I/O pin.

### 17.3.3 Interrupts

**Table 17-3. Available Interrupt Vectors and Sources**

Name	Vector Description	Conditions
PORTx	PORT interrupt	INTn in PORTx.INTFLAGS is raised as configured by the Input/Sense Configuration (ISC) bit in PORTx.PINnCTRL

Each PORT pin n can be configured as an interrupt source. Each interrupt can be individually enabled or disabled by writing to ISC in PORTx.PINnCTRL.

When an interrupt condition occurs, the corresponding interrupt flag is set in the Interrupt Flags register of the peripheral (*peripheral*.INTFLAGS).

An interrupt request is generated when the corresponding interrupt source is enabled, and the interrupt flag is set. The interrupt request remains active until the interrupt flag is cleared. See the peripheral's INTFLAGS register for details on how to clear interrupt flags.

When setting or changing interrupt settings, take these points into account:

- If an Inverted I/O Enable (INVEN) bit is toggled in the same cycle as ISC is changed, the edge caused by the inversion toggling may not cause an interrupt request
- If an input is disabled by writing to ISC while synchronizing an interrupt, that interrupt may be requested on re-enabling the input, even if it is re-enabled with a different interrupt setting
- If the interrupt setting is changed by writing to ISC while synchronizing an interrupt, that interrupt may not be requested

#### 17.3.3.1 Asynchronous Sensing Pin Properties

All PORT pins support asynchronous input sensing with interrupts for selectable pin change conditions. Fully asynchronous pin change sensing can trigger an interrupt and wake the device from all sleep modes, including modes where the Peripheral Clock (CLK\_PER) is stopped, while partially asynchronous pin change sensing is limited as per the table below. See the *I/O Multiplexing and Considerations* section for further details on which pins support fully asynchronous pin change sensing.

**Table 17-4. Behavior Comparison of Sense Pins**

Property	Partially Asynchronous Pins	Fully Asynchronous Pins
Waking the device from sleep modes with CLK_PER running	From all interrupt sense configurations	From all interrupt sense configurations
Waking the device from sleep modes with CLK_PER stopped	Only from BOTHEDGES or LEVEL interrupt sense configurations	
Minimum pulse-width to trigger an interrupt with CLK_PER running	Minimum one CLK_PER cycle	Less than one CLK_PER cycle
Minimum pulse-width to trigger an interrupt with CLK_PER stopped	The pin value must be kept until CLK_PER has restarted <sup>(1)</sup>	
Interrupt "dead-time"	No new interrupt for three CLK_PER cycles after the previous	

**Note:**

1. If a partially asynchronous input pin is used for wake-up from sleep with CLK\_PER stopped, the required level must be held long enough for the MCU to complete the wake-up to trigger the interrupt. If the level disappears, the MCU can wake up without any interrupt generated.

### 17.3.4 Events

PORT can generate the following events:

**Table 17-5. Event Generators in PORTx**

Generator Name		Description	Event Type	Generating Clock Domain	Length of Event
Peripheral	Event				
PORTx	PINn	Pin level	Level	Asynchronous	Given by pin level

All PORT pins are asynchronous event system generators. PORT has as many event generators as there are PORT pins in the device. Each event system output from PORT is the value present on the corresponding pin if the digital input buffer is enabled. If a pin input buffer is disabled, the corresponding event system output is zero.

PORT has no event inputs. Refer to the *Event System (EVSYS)* section for more details regarding event types and Event System configuration.

### 17.3.5 Sleep Mode Operation

Except for interrupts and input synchronization, all pin configurations are independent of sleep modes. All pins can wake the device from sleep, see the PORT Interrupt section for further details.

Peripherals connected to the PORTs can be affected by sleep modes, described in the respective peripherals' data sheet section.



**Important:** The PORTs will always use the Peripheral Clock (CLK\_PER). Input synchronization will halt when this clock stops.

### 17.3.6 Debug Operation

When the CPU is halted in Debug mode, the PORT continues normal operation. If the PORT is configured in a way that requires it to be periodically serviced by the CPU through interrupts or similar, improper operation or data loss may result during debugging.



### 17.4 Register Summary - PORTx

Offset	Name	Bit Pos.	7	6	5	4	3	2	1	0
0x00	<a href="#">DIR</a>	7:0	DIR[7:0]							
0x01	<a href="#">DIRSET</a>	7:0	DIRSET[7:0]							
0x02	<a href="#">DIRCLR</a>	7:0	DIRCLR[7:0]							
0x03	<a href="#">DIRTGL</a>	7:0	DIRTGL[7:0]							
0x04	<a href="#">OUT</a>	7:0	OUT[7:0]							
0x05	<a href="#">OUTSET</a>	7:0	OUTSET[7:0]							
0x06	<a href="#">OUTCLR</a>	7:0	OUTCLR[7:0]							
0x07	<a href="#">OUTTGL</a>	7:0	OUTTGL[7:0]							
0x08	<a href="#">IN</a>	7:0	IN[7:0]							
0x09	<a href="#">INTFLAGS</a>	7:0	INT[7:0]							
0x0A	<a href="#">PORTCTRL</a>	7:0								SRL
0x0B	<a href="#">PINCONFIG</a>	7:0	INVEN				PULLUPEN		ISC[2:0]	
0x0C	<a href="#">PINCTRLUPD</a>	7:0	PINCTRLUPD[7:0]							
0x0D	<a href="#">PINCTRLSET</a>	7:0	PINCTRLSET[7:0]							
0x0E	<a href="#">PINCTRLCLR</a>	7:0	PINCTRLCLR[7:0]							
0x0F	Reserved									
0x10	<a href="#">PIN0CTRL</a>	7:0	INVEN				PULLUPEN		ISC[2:0]	
0x11	<a href="#">PIN1CTRL</a>	7:0	INVEN				PULLUPEN		ISC[2:0]	
0x12	<a href="#">PIN2CTRL</a>	7:0	INVEN				PULLUPEN		ISC[2:0]	
0x13	<a href="#">PIN3CTRL</a>	7:0	INVEN				PULLUPEN		ISC[2:0]	
0x14	<a href="#">PIN4CTRL</a>	7:0	INVEN				PULLUPEN		ISC[2:0]	
0x15	<a href="#">PIN5CTRL</a>	7:0	INVEN				PULLUPEN		ISC[2:0]	
0x16	<a href="#">PIN6CTRL</a>	7:0	INVEN				PULLUPEN		ISC[2:0]	
0x17	<a href="#">PIN7CTRL</a>	7:0	INVEN				PULLUPEN		ISC[2:0]	

### 17.5 Register Description - PORTx

## 17.5.1 Data Direction

**Name:** DIR  
**Offset:** 0x00  
**Reset:** 0x00  
**Property:** -

Bit	7	6	5	4	3	2	1	0
	DIR[7:0]							
Access	R/W	R/W	R/W	R/W	R/W	R/W	R/W	R/W
Reset	0	0	0	0	0	0	0	0

**Bits 7:0 – DIR[7:0]** Data Direction

This bit field controls the output driver for each PORTx pin.

This bit field does not control the digital input buffer. The digital input buffer for pin n (Pxn) can be configured in the Input/Sense Configuration (ISC) bit field in the Pin n Control (PORTx.PINnCTRL) register.

The available configuration for each bit n in this bit field is shown in the table below.

Value	Description
0	Pxn is configured as an input-only pin, and the output driver is disabled
1	Pxn is configured as an output pin, and the output driver is enabled

**17.5.2 Data Direction Set**

**Name:** DIRSET  
**Offset:** 0x01  
**Reset:** 0x00  
**Property:** -

	7	6	5	4	3	2	1	0
	DIRSET[7:0]							
Access	R/W	R/W	R/W	R/W	R/W	R/W	R/W	R/W
Reset	0	0	0	0	0	0	0	0

**Bits 7:0 – DIRSET[7:0] Data Direction Set**

This bit field controls the output driver for each PORTx pin, without using a read-modify-write operation.

Writing a '0' to bit n in this bit field has no effect.

Writing a '1' to bit n in this bit field will set the corresponding bit in PORTx.DIR, which will configure pin n (Pxn) as an output pin and enable the output driver.

Reading this bit field will return the value of PORTx.DIR.

**17.5.3 Data Direction Clear**

**Name:** DIRCLR  
**Offset:** 0x02  
**Reset:** 0x00  
**Property:** -

Bit	7	6	5	4	3	2	1	0
	DIRCLR[7:0]							
Access	R/W	R/W	R/W	R/W	R/W	R/W	R/W	R/W
Reset	0	0	0	0	0	0	0	0

**Bits 7:0 – DIRCLR[7:0]** Data Direction Clear

This bit field controls the output driver for each PORTx pin, without using a read-modify-write operation.

Writing a '0' to bit n in this bit field has no effect.

Writing a '1' to bit n in this bit field will clear the corresponding bit in PORTx.DIR, which will configure pin n (Pxn) as an input-only pin and disable the output driver.

Reading this bit field will return the value of PORTx.DIR.

**17.5.4 Data Direction Toggle**

**Name:** DIRTGL  
**Offset:** 0x03  
**Reset:** 0x00  
**Property:** -

Bit	7	6	5	4	3	2	1	0
	DIRTGL[7:0]							
Access	R/W	R/W	R/W	R/W	R/W	R/W	R/W	R/W
Reset	0	0	0	0	0	0	0	0

**Bits 7:0 – DIRTGL[7:0] Data Direction Toggle**

This bit field controls the output driver for each PORTx pin, without using a read-modify-write operation.

Writing a '0' to bit n in this bit field has no effect.

Writing a '1' to bit n in this bit field will toggle the corresponding bit in PORTx.DIR.

Reading this bit field will return the value of PORTx.DIR.

**17.5.5 Output Value**

**Name:** OUT  
**Offset:** 0x04  
**Reset:** 0x00  
**Property:** -

	7	6	5	4	3	2	1	0
	OUT[7:0]							
Access	R/W	R/W	R/W	R/W	R/W	R/W	R/W	R/W
Reset	0	0	0	0	0	0	0	0

**Bits 7:0 – OUT[7:0] Output Value**

This bit field controls the output driver level for each PORTx pin.

This configuration only has an effect when the output driver (PORTx.DIR) is enabled for the corresponding pin.

The available configuration for each bit n in this bit field is shown in the table below.

Value	Description
0	The pin n (Pxn) output is driven low
1	The Pxn output is driven high

**17.5.6 Output Value Set**

**Name:** OUTSET  
**Offset:** 0x05  
**Reset:** 0x00  
**Property:** -

Bit	7	6	5	4	3	2	1	0
	OUTSET[7:0]							
Access	R/W	R/W	R/W	R/W	R/W	R/W	R/W	R/W
Reset	0	0	0	0	0	0	0	0

**Bits 7:0 – OUTSET[7:0]** Output Value Set

This bit field controls the output driver level for each PORTx pin, without using a read-modify-write operation.

Writing a '0' to bit n in this bit field has no effect.

Writing a '1' to bit n in this bit field will set the corresponding bit in PORTx.OUT, which will configure the output for pin n (Pxn) to be driven high.

Reading this bit field will return the value of PORTx.OUT.

**17.5.7 Output Value Clear**

**Name:** OUTCLR  
**Offset:** 0x06  
**Reset:** 0x00  
**Property:** -

Bit	7	6	5	4	3	2	1	0
	OUTCLR[7:0]							
Access	R/W	R/W	R/W	R/W	R/W	R/W	R/W	R/W
Reset	0	0	0	0	0	0	0	0

**Bits 7:0 – OUTCLR[7:0]** Output Value Clear

This bit field controls the output driver level for each PORTx pin, without using a read-modify-write operation.

Writing a '0' to bit n in this bit field has no effect.

Writing a '1' to bit n in this bit field will clear the corresponding bit in PORTx.OUT, which will configure the output for pin n (Pxn) to be driven low.

Reading this bit field will return the value of PORTx.OUT.



**17.5.8 Output Value Toggle**

**Name:** OUTTGL  
**Offset:** 0x07  
**Reset:** 0x00  
**Property:** -

Bit	7	6	5	4	3	2	1	0
	OUTTGL[7:0]							
Access	R/W	R/W	R/W	R/W	R/W	R/W	R/W	R/W
Reset	0	0	0	0	0	0	0	0

**Bits 7:0 – OUTTGL[7:0]** Output Value Toggle

This bit field controls the output driver level for each PORTx pin, without using a read-modify-write operation.

Writing a '0' to bit n in this bit field has no effect.

Writing a '1' to bit n in this bit field will toggle the corresponding bit in PORTx.OUT.

Reading this bit field will return the value of PORTx.OUT.

## 17.5.9 Input Value

**Name:** IN  
**Offset:** 0x08  
**Reset:** 0x00  
**Property:** -

Bit	7	6	5	4	3	2	1	0
	IN[7:0]							
Access	R/W	R/W	R/W	R/W	R/W	R/W	R/W	R/W
Reset	0	0	0	0	0	0	0	0

**Bits 7:0 – IN[7:0]** Input Value

This bit field shows the state of the PORTx pins when the digital input buffer is enabled.

Writing a '0' to bit n in this bit field has no effect.

Writing a '1' to bit n in this bit field will toggle the corresponding bit in PORTx.OUT.

If the digital input buffer is disabled, the input is not sampled, and the bit value will not change. The digital input buffer for pin n (Pxn) can be configured in the Input/Sense Configuration (ISC) bit field in the Pin n Control (PORTx.PINnCTRL) register.

The available states of each bit n in this bit field is shown in the table below.

Value	Description
0	The voltage level on Pxn is low
1	The voltage level on Pxn is high

**17.5.10 Interrupt Flags**

**Name:** INTFLAGS  
**Offset:** 0x09  
**Reset:** 0x00  
**Property:** -

Bit	7	6	5	4	3	2	1	0
	INT[7:0]							
Access	R/W	R/W	R/W	R/W	R/W	R/W	R/W	R/W
Reset	0	0	0	0	0	0	0	0

**Bits 7:0 – INT[7:0] Pin Interrupt Flag**

Pin interrupt flag n is cleared by writing a '1' to it.

Pin interrupt flag n is set when the change or state of pin n (Pxn) matches the pin's Input/Sense Configuration (ISC) in PORTx.PINnCTRL.

Writing a '0' to bit n in this bit field has no effect.

Writing a '1' to bit n in this bit field will clear Pin interrupt flag n.

### 17.5.11 Port Control

**Name:** PORTCTRL  
**Offset:** 0x0A  
**Reset:** 0x00  
**Property:** -

This register contains the slew rate limit enable bit for this port.

Bit	7	6	5	4	3	2	1	0
								SRL
Access								R/W
Reset								0

#### Bit 0 – SRL Slew Rate Limit Enable

This bit controls the slew rate limitation for all pins in PORTx.

Value	Description
0	Slew rate limitation is disabled for all pins in PORTx
1	Slew rate limitation is enabled for all pins in PORTx

### 17.5.12 Multi-Pin Configuration

**Name:** PINCONFIG  
**Offset:** 0x0B  
**Reset:** 0x00  
**Property:** -

The multi-pin configuration write enables the configuration of several pins of a port in a single cycle, for faster configuration of the port module. Especially with large pin count devices, this function can significantly speed up PORT pin configuration operations.

Writing to this register may be followed by a write to either of the Multi-Pin Control (PORTx.PINCTRLUPD/SET/CLR) registers to update the Pin n Control (PORTx.PINnCTRL) registers for PORTx.

This register is mirrored across all PORTx modules.

	7	6	5	4	3	2	1	0
	INVEN				PULLUPEN		ISC[2:0]	
Access	R/W				R/W	R/W	R/W	R/W
Reset	0				0	0	0	0

#### Bit 7 – INVEN Inverted I/O Enable

This bit controls whether the input and output for pin n are inverted or not.

Value	Description
0	Input and output values are not inverted
1	Input and output values are inverted

#### Bit 3 – PULLUPEN Pull-up Enable

This bit controls whether the internal pull-up of pin n is enabled or not when the pin is configured as input-only.

Value	Description
0	Pull-up disabled
1	Pull-up enabled

#### Bits 2:0 – ISC[2:0] Input/Sense Configuration

This bit field controls the input and sense configuration of pin n. The sense configuration determines how a port interrupt can be triggered.

Value	Name	Description
0x0	INTDISABLE	Interrupt disabled but digital input buffer enabled
0x1	BOTHEDGES	Interrupt enabled with sense on both edges
0x2	RISING	Interrupt enabled with sense on rising edge
0x3	FALLING	Interrupt enabled with sense on falling edge
0x4	INPUT_DISABLE	Interrupt and digital input buffer disabled <sup>(1)</sup>
0x5	LEVEL	Interrupt enabled with sense on low level
other	—	Reserved

#### Note:

- If the digital input buffer for pin n is disabled, bit n in the Input Value (PORTx.IN) register will not be updated.

### 17.5.13 Multi-Pin Control Update Mask

**Name:** PINCTRLUPD  
**Offset:** 0x0C  
**Reset:** 0x00  
**Property:** -

The multi-pin configuration write enables the configuration of several pins of a port in a single cycle, for faster configuration of the port module. Especially with large pin count devices, this function can significantly speed up port pin configuration operations.

Bit	7	6	5	4	3	2	1	0
	PINCTRLUPD[7:0]							
Access	R/W	R/W	R/W	R/W	R/W	R/W	R/W	R/W
Reset	0	0	0	0	0	0	0	0

**Bits 7:0 – PINCTRLUPD[7:0]** Multi-Pin Control Update Mask

This bit field controls the copy of the Multi-Pin Configuration (PORTx.PINCONFIG) register content to the individual Pin n Control (PORTx.PINnCTRL) registers, without using an individual write operation for each register.

Writing a '0' to bit n in this bit field has no effect.

Writing a '1' to bit n in this bit field will copy the PORTx.PINCONFIG register content to the corresponding PORTx.PINnCTRL register.

Reading this bit field will always return zero.

**17.5.14 Multi-Pin Control Set Mask**

**Name:** PINCTRLSET  
**Offset:** 0x0D  
**Reset:** 0x00  
**Property:** -

The multi-pin configuration write enables the configuration of several pins of a port in a single cycle, for faster configuration of the port module. Especially with large pin count devices, this function can significantly speed up port pin configuration operations.

Bit	7	6	5	4	3	2	1	0
	PINCTRLSET[7:0]							
Access	R/W	R/W	R/W	R/W	R/W	R/W	R/W	R/W
Reset	0	0	0	0	0	0	0	0

**Bits 7:0 – PINCTRLSET[7:0] Multi-Pin Control Set Mask**

This bit field controls the setting of bits in the individual Pin n Control (PORTx.PINnCTRL) registers, without using an individual read-modify-write operation for each register.

Writing a '0' to bit n in this bit field has no effect.

Writing a '1' to bit n in this bit field will set the individual bits in the PORTx.PINnCTRL register, according to the bits set to '1' in the Multi-Pin Configuration (PORTx.PINCONFIG) register.

Reading this bit field will always return zero.

**17.5.15 Multi-Pin Control Clear Mask**

**Name:** PINCTRLCLR  
**Offset:** 0x0E  
**Reset:** 0x00  
**Property:** -

The multi-pin configuration write enables the configuration of several pins of a port in a single cycle, for faster configuration of the port module. Especially with large pin count devices, this function can significantly speed up port pin configuration operations.

Bit	7	6	5	4	3	2	1	0
	PINCTRLCLR[7:0]							
Access	R/W	R/W	R/W	R/W	R/W	R/W	R/W	R/W
Reset	0	0	0	0	0	0	0	0

**Bits 7:0 – PINCTRLCLR[7:0] Multi-Pin Control Clear Mask**

This bit field controls the clearing of bits in the individual Pin n Control (PORTx.PINnCTRL) registers, without using an individual read-modify-write operation for each register.

Writing a '0' to bit n in this bit field has no effect.

Writing a '1' to bit n in this bit field will clear the individual bits in the PORTx.PINnCTRL register, according to the bits set to '1' in the Multi-Pin Configuration (PORTx.PINCONFIG) register.

Reading this bit field will always return zero.



### 17.5.16 Pin n Control

**Name:** PINnCTRL  
**Offset:** 0x10 + n\*0x01 [n=0..7]  
**Reset:** 0x00  
**Property:** -

	Bit	7	6	5	4	3	2	1	0
		INVEN				PULLUPEN		ISC[2:0]	
Access		R/W				R/W		R/W	R/W
Reset		0				0		0	0

#### Bit 7 – INVEN Inverted I/O Enable

This bit controls whether the input and output for pin n are inverted or not.

Value	Description
0	Input and output values are not inverted
1	Input and output values are inverted

#### Bit 3 – PULLUPEN Pull-up Enable

This bit controls whether the internal pull-up of pin n is enabled or not when the pin is configured as input-only.

Value	Description
0	Pull-up disabled
1	Pull-up enabled

#### Bits 2:0 – ISC[2:0] Input/Sense Configuration

This bit field controls the input and sense configuration of pin n. The sense configuration determines how a port interrupt can be triggered.

Value	Name	Description
0x0	INTDISABLE	Interrupt disabled but digital input buffer enabled
0x1	BOTHEDGES	Interrupt enabled with sense on both edges
0x2	RISING	Interrupt enabled with sense on rising edge
0x3	FALLING	Interrupt enabled with sense on falling edge
0x4	INPUT_DISABLE	Interrupt and digital input buffer disabled <sup>(1)</sup>
0x5	LEVEL	Interrupt enabled with sense on low level
other	—	Reserved

#### Note:

1. If the digital input buffer for pin n is disabled, bit n in the Input Value (PORTx.IN) register will not be updated.

## 17.6 Register Summary - VPORtx

Offset	Name	Bit Pos.	7	6	5	4	3	2	1	0
0x00	DIR	7:0								DIR[7:0]
0x01	OUT	7:0								OUT[7:0]
0x02	IN	7:0								IN[7:0]
0x03	INTFLAGS	7:0								INT[7:0]

## 17.7 Register Description - VPORtx

### 17.7.1 Data Direction

**Name:** DIR  
**Offset:** 0x00  
**Reset:** 0x00  
**Property:** -

Access to the Virtual PORT registers has the same outcome as access to the regular registers but allows for memory specific instructions, such as bit manipulation instructions, which cannot be used in the extended I/O Register space where the regular PORT registers reside.

Bit	7	6	5	4	3	2	1	0
	DIR[7:0]							
Access	R/W	R/W	R/W	R/W	R/W	R/W	R/W	R/W
Reset	0	0	0	0	0	0	0	0

#### Bits 7:0 – DIR[7:0] Data Direction

This bit field controls the output driver for each PORTx pin.

This bit field does not control the digital input buffer. The digital input buffer for pin n (Pxn) can be configured in the Input/Sense Configuration (ISC) bit field in the Pin n Control (PORTx.PINnCTRL) register.

The available configuration for each bit n in this bit field is shown in the table below.

Value	Description
0	Pxn is configured as an input-only pin, and the output driver is disabled
1	Pxn is configured as an output pin, and the output driver is enabled

## 17.7.2 Output Value

**Name:** OUT  
**Offset:** 0x01  
**Reset:** 0x00  
**Property:** -

Access to the Virtual PORT registers has the same outcome as access to the regular registers but allows for memory specific instructions, such as bit manipulation instructions, which cannot be used in the extended I/O Register space where the regular PORT registers reside.

Bit	7	6	5	4	3	2	1	0
	OUT[7:0]							
Access	R/W	R/W	R/W	R/W	R/W	R/W	R/W	R/W
Reset	0	0	0	0	0	0	0	0

**Bits 7:0 – OUT[7:0]** Output Value

This bit field controls the output driver level for each PORTx pin.

This configuration only has an effect when the output driver (PORTx.DIR) is enabled for the corresponding pin.

The available configuration for each bit n in this bit field is shown in the table below.

Value	Description
0	The pin n (Pxn) output is driven low
1	The Pxn output is driven high

### 17.7.3 Input Value

**Name:** IN  
**Offset:** 0x02  
**Reset:** 0x00  
**Property:** -

Access to the Virtual PORT registers has the same outcome as access to the regular registers but allows for memory specific instructions, such as bit manipulation instructions, which cannot be used in the extended I/O Register space where the regular PORT registers reside.

Bit	7	6	5	4	3	2	1	0
	IN[7:0]							
Access	R/W	R/W	R/W	R/W	R/W	R/W	R/W	R/W
Reset	0	0	0	0	0	0	0	0

#### Bits 7:0 – IN[7:0] Input Value

This bit field shows the state of the PORTx pins when the digital input buffer is enabled.

Writing a '0' to bit n in this bit field has no effect.

Writing a '1' to bit n in this bit field will toggle the corresponding bit in PORTx.OUT.

If the digital input buffer is disabled, the input is not sampled, and the bit value will not change. The digital input buffer for pin n (Pxn) can be configured in the Input/Sense Configuration (ISC) bit field in the Pin n Control (PORTx.PINnCTRL) register.

The available states of each bit n in this bit field is shown in the table below.

Value	Description
0	The voltage level on Pxn is low
1	The voltage level on Pxn is high

### 17.7.4 Interrupt Flags

**Name:** INTFLAGS  
**Offset:** 0x03  
**Reset:** 0x00  
**Property:** -

Access to the Virtual PORT registers has the same outcome as access to the regular registers but allows for memory specific instructions, such as bit manipulation instructions, which cannot be used in the extended I/O Register space where the regular PORT registers reside.

Bit	7	6	5	4	3	2	1	0
	INT[7:0]							
Access	R/W	R/W	R/W	R/W	R/W	R/W	R/W	R/W
Reset	0	0	0	0	0	0	0	0

#### Bits 7:0 – INT[7:0] Pin Interrupt Flag

Pin interrupt flag n is cleared by writing a '1' to it.

Pin interrupt flag n is set when the change or state of pin n (Pxn) matches the pin's Input/Sense Configuration (ISC) in PORTx.PINnCTRL.

Writing a '0' to bit n in this bit field has no effect.

Writing a '1' to bit n in this bit field will clear Pin interrupt flag n.

## **18. BOD - Brown-out Detector**

### **18.1 Features**

- Brown-out Detector Monitors the Power Supply to Avoid Operation Below a Programmable Level
- Three Available Modes:
  - Enabled mode (continuously active)
  - Sampled mode
  - Disabled
- Separate Selection of Mode for Active and Sleep Modes
- Voltage Level Monitor (VLM) with Interrupt
- Programmable VLM Level Relative to the BOD Level

### **18.2 Overview**

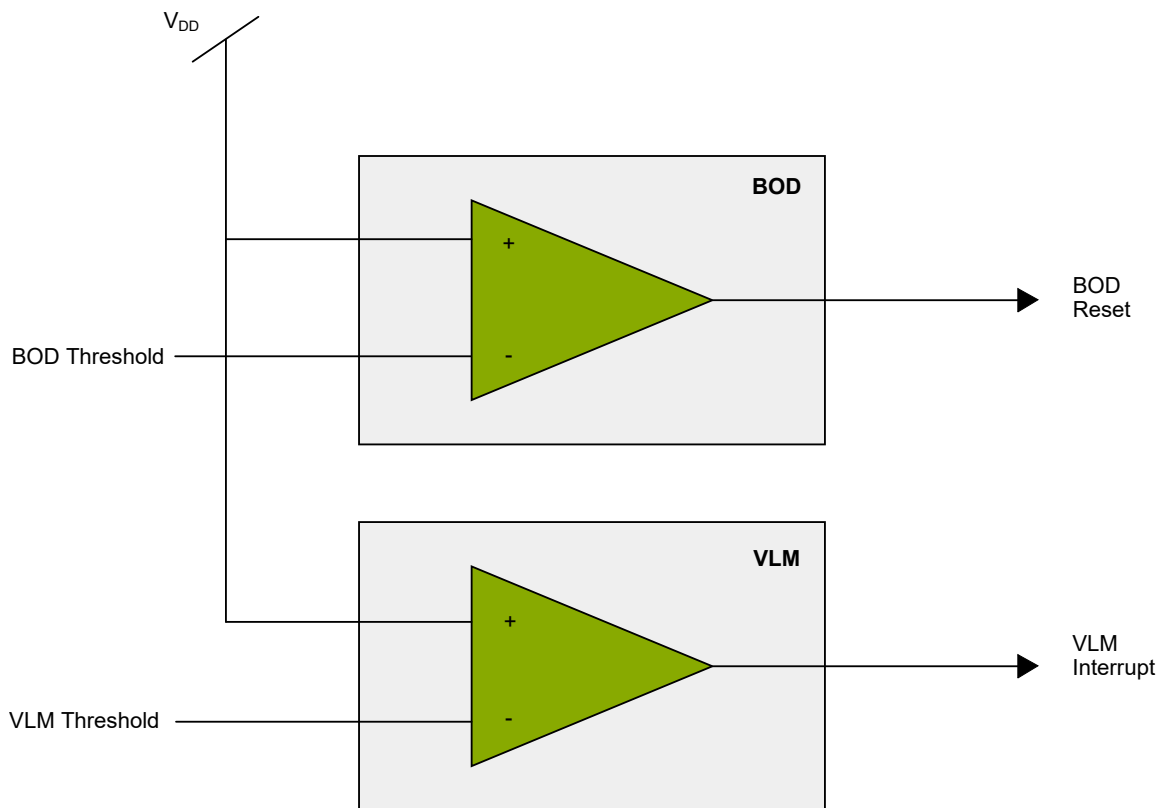
The Brown-out Detector (BOD) monitors the power supply and compares the supply voltage with the programmable brown-out threshold level. The brown-out threshold level defines when to generate a System Reset. The Voltage Level Monitor (VLM) monitors the power supply and compares it to a threshold higher than the BOD threshold. The VLM can then generate an interrupt as an “early warning” when the supply voltage is approaching the BOD threshold. The VLM threshold level is expressed as a percentage above the BOD threshold level.

The BOD is controlled mainly by fuses and has to be enabled by the user. The mode used in Standby sleep mode and Power-Down sleep mode can be altered in normal program execution. The VLM is controlled by I/O registers as well.

When activated, the BOD can operate in Enabled mode, where the BOD is continuously active, or in Sampled mode, where the BOD is activated briefly at a given period to check the supply voltage level.

18.2.1 Block Diagram

Figure 18-1. BOD Block Diagram



18.3 Functional Description

18.3.1 Initialization

The BOD settings are loaded from fuses during Reset. The BOD level and operating mode in Active mode and Idle sleep mode are set by fuses and cannot be changed by software. The operating mode in Standby and Power-Down sleep mode is loaded from fuses and can be changed by software.

The Voltage Level Monitor function can be enabled by writing a '1' to the VLM Interrupt Enable (VLMIE) bit in the Interrupt Control (BOD.INTCTRL) register. The VLM interrupt is configured by writing the VLM Configuration (VLMCFG) bits in BOD.INTCTRL. An interrupt is requested when the supply voltage crosses the VLM threshold from either above or below.

The VLM functionality will follow the BOD mode. If the BOD is disabled, the VLM will not be enabled, even if the VLMIE is '1'. If the BOD is using Sampled mode, the VLM will also be sampled. When enabling the VLM interrupt, the interrupt flag will always be set if VLMCFG equals  $0 \times 2$ , and may be set if VLMCFG is configured to  $0 \times 0$  or  $0 \times 1$ .

The VLM threshold is defined by writing the VLM Level (VLMLVL) bits in the VLM Control (BOD.VLMCTRL) register.

18.3.2 Interrupts

Table 18-1. Available Interrupt Vectors and Sources

Name	Vector Description	Conditions
VLM	Voltage Level Monitor	Supply voltage crossing the VLM threshold as configured by the VLM Configuration (VLMCFG) bit field in the Interrupt Control (BOD.INTCTRL) register



The VLM interrupt will not be executed if the CPU is halted in Debug mode.

When an interrupt condition occurs, the corresponding interrupt flag is set in the peripheral's Interrupt Flags (*peripheral*.INTFLAGS) register.

An interrupt source is enabled or disabled by writing to the corresponding enable bit in the peripheral's Interrupt Control (*peripheral*.INTCTRL) register.

An interrupt request is generated when the corresponding interrupt source is enabled, and the interrupt flag is set. The interrupt request remains active until the interrupt flag is cleared. See the peripheral's INTFLAGS register for details on how to clear interrupt flags.

### 18.3.3 Sleep Mode Operation

The BOD configuration in the different sleep modes is defined by fuses. The mode used in Active mode and Idle sleep mode is defined by the ACTIVE fuses in FUSE.BODCFG, which is loaded into the ACTIVE bit field in the Control A (BOD.CTRLA) register. The mode used in Standby sleep mode and Power-Down sleep mode is defined by SLEEP in FUSE.BODCFG, which is loaded into the SLEEP bit field in the Control A (BOD.CTRLA) register.

The operating mode in Active mode and Idle sleep mode (i.e., ACTIVE in BOD.CTRLA) cannot be altered by software. The operating mode in Standby sleep mode and Power-Down sleep mode can be altered by writing to the SLEEP bit field in the Control A (BOD.CTRLA) register.

When the device is going into Standby or Power-Down sleep mode, the BOD will change the operation mode as defined by SLEEP in BOD.CTRLA. When the device is waking up from Standby or Power-Down sleep mode, the BOD will operate in the mode defined by the ACTIVE bit field in the Control A (BOD.CTRLA) register.

### 18.3.4 Configuration Change Protection

This peripheral has registers that are under Configuration Change Protection (CCP). To write to these registers, a certain key must first be written to the CPU.CCP register, followed by a write access to the protected bits within four CPU instructions.

Attempting to write to a protected register without following the appropriate CCP unlock sequence leaves the protected register unchanged.

The following registers are under CCP:

**Table 18-2. Registers Under Configuration Change Protection**

Register	Key
The SLEEP and SAMPFREQ bits in the BOD.CTRLA register	IOREG

## 18.4 Register Summary

Offset	Name	Bit Pos.	7	6	5	4	3	2	1	0
0x00	<a href="#">CTRLA</a>	7:0				SAMPFREQ		ACTIVE[1:0]		SLEEP[1:0]
0x01	<a href="#">CTRLB</a>	7:0								LVL[2:0]
0x02	Reserved									
...										
0x07										
0x08		<a href="#">VLMCTRL</a>	7:0							
0x09	<a href="#">INTCTRL</a>	7:0							VLMCFG[1:0]	VLMIE
0x0A	<a href="#">INTFLAGS</a>	7:0								VLMIIF
0x0B	<a href="#">STATUS</a>	7:0								VLMS

## 18.5 Register Description

### 18.5.1 Control A

**Name:** CTRLA  
**Offset:** 0x00  
**Reset:** 0x00  
**Property:** Configuration Change Protection

Bit	7	6	5	4	3	2	1	0
				SAMPFREQ	ACTIVE[1:0]		SLEEP[1:0]	
Access				R	R	R	R/W	R/W
Reset				0	0	0	0	0

#### Bit 4 – SAMPFREQ Sample Frequency

This bit controls the BOD sample frequency.

The Reset value is loaded from the SAMPFREQ bit in FUSE.BODCFG.

This bit is not under Configuration Change Protection (CCP).

Value	Description
0x0	Sample frequency is 128 Hz
0x1	Sample frequency is 32 Hz

#### Bits 3:2 – ACTIVE[1:0] Active

These bits select the BOD operation mode when the device is in Active mode or Idle sleep mode.

The Reset value is loaded from the ACTIVE bits in FUSE.BODCFG.

These bits are not under Configuration Change Protection (CCP).

Value	Name	Description
0x0	DIS	Disabled
0x1	ENABLED	Enabled in Continuous mode
0x2	SAMPLE	Enabled in Sampled mode
0x3	ENWAKE	Enabled in Continuous mode. Execution is halted at wake-up until BOD is running.

#### Bits 1:0 – SLEEP[1:0] Sleep

These bits select the BOD operation mode when the device is in Standby or Power-Down sleep mode. The Reset value is loaded from the SLEEP bits in FUSE.BODCFG.

Value	Name	Description
0x0	DIS	Disabled
0x1	ENABLED	Enabled in Continuous mode
0x2	SAMPLED	Enabled in Sampled mode
0x3	-	Reserved

## 18.5.2 Control B

**Name:** CTRLB  
**Offset:** 0x01  
**Reset:** Loaded from fuse  
**Property:** -

Bit	7	6	5	4	3	2	1	0
							LVL[2:0]	
Access	R	R	R	R	R	R	R	R
Reset	0	0	0	0	0	x	x	x

**Bits 2:0 – LVL[2:0]** BOD Level

This bit field controls the BOD threshold level.

The Reset value is loaded from the BOD Level (LVL) bits in the BOD Configuration Fuse (FUSE.BODCFG).

Value	Name	Typical Values
0x0	BODLEVEL0	1.9V
0x1	BODLEVEL1	2.45V
0x2	BODLEVEL2	2.7V
0x3	BODLEVEL3	2.85V
Other	—	Reserved

**Note:** Refer to the *Reset, WDT, Oscillator, Start-up Timer, Power-up Timer, Brown-out Detector Specifications* section for BOD level characterization.

## 18.5.3 VLM Control

**Name:** VLMCTRL  
**Offset:** 0x08  
**Reset:** 0x00  
**Property:** -

Bit	7	6	5	4	3	2	1	0
							VLMVL[1:0]	
Access							R/W	R/W
Reset							0	0

**Bits 1:0 – VLMVL[1:0]** VLM Level

These bits select the VLM threshold relative to the BOD threshold (LVL in BOD.CTRLB).

Value	Name	Description
0x00	OFF	VLM disabled
0x01	5ABOVE	VLM threshold 5% above the BOD threshold
0x02	15ABOVE	VLM threshold 15% above the BOD threshold
0x03	25ABOVE	VLM threshold 25% above the BOD threshold

### 18.5.4 Interrupt Control

**Name:** INTCTRL  
**Offset:** 0x09  
**Reset:** 0x00  
**Property:** -

Bit	7	6	5	4	3	2	1	0
						VLMCFG[1:0]		VLMIE
Access						R/W	R/W	R/W
Reset						0	0	0

#### Bits 2:1 – VLMCFG[1:0] VLM Configuration

These bits select which incidents will trigger a VLM interrupt.

Value	Name	Description
0x0	FALLING	$V_{DD}$ falls below VLM threshold
0x1	RISING	$V_{DD}$ rises above VLM threshold
0x2	BOTH	$V_{DD}$ crosses VLM threshold
Other	-	Reserved

#### Bit 0 – VLMIE VLM Interrupt Enable

Writing a '1' to this bit enables the VLM interrupt.

### 18.5.5 VLM Interrupt Flags

**Name:** INTFLAGS  
**Offset:** 0x0A  
**Reset:** 0x00  
**Property:** -

Bit	7	6	5	4	3	2	1	0
								VLMIF
Access								R/W
Reset								0

**Bit 0 – VLMIF** VLM Interrupt Flag

This flag is set when a trigger from the VLM is given, as configured by the VLMCFG bit in the BOD.INTCTRL register. The flag is only updated when the BOD is enabled.

### 18.5.6 VLM Status

**Name:** STATUS  
**Offset:** 0x0B  
**Reset:** 0x00  
**Property:** -

Bit	7	6	5	4	3	2	1	0
								VLMS
Access								R/W
Reset								0

#### Bit 0 – VLMS VLM Status

This bit is only valid when the BOD is enabled.

Value	Name	Description
0	ABOVE	The voltage is above the VLM threshold level
1	BELOW	The voltage is below the VLM threshold level



## 19. VREF - Voltage Reference

### 19.1 Features

- Programmable Voltage Reference Sources:
  - One reference for Analog-to-Digital Converter 0 (ADC0)
  - One reference for Digital-to-Analog Converter 0 (DAC0)
  - One reference shared between all Analog Comparators (ACs)
- Each Reference Source Supports the Following Voltages:
  - 1.024V
  - 2.048V
  - 4.096V
  - 2.500V
  - VDD
  - VREFA

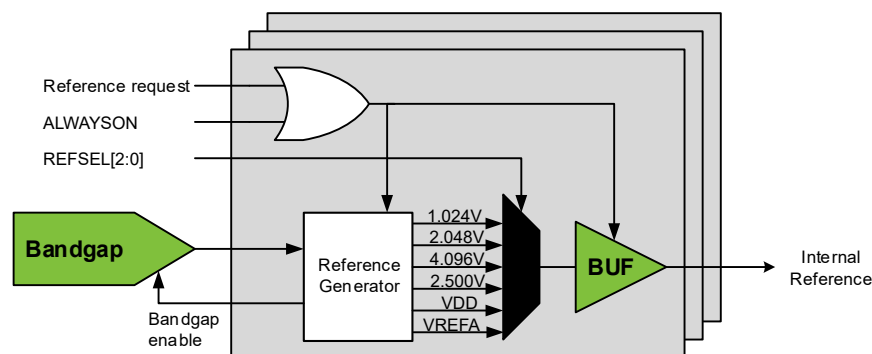
### 19.2 Overview

The Voltage Reference (VREF) peripheral provides control registers for the voltage reference sources used by several peripherals. The user can select the reference voltages for the ADC0, DAC0 and ACs by writing to the appropriate registers in the VREF peripheral.

A voltage reference source is enabled automatically when requested by a peripheral. The user can enable the reference voltage sources, and thus, override the automatic disabling of unused sources by writing to the respective ALWAYSON bit in VREF.ADC0REF, VREF.DAC0REF and VREF.ACREF. This will decrease the start-up time at the cost of increased power consumption.

#### 19.2.1 Block Diagram

Figure 19-1. VREF Block Diagram



## 19.3 Functional Description

### 19.3.1 Initialization

The default configuration will enable the respective source when the ADC0, DAC0, or any of the ACs are requesting a reference voltage. The default reference voltage is 1.024V but can be configured by writing to the respective Reference Select (REFSEL) bit field in the ADC0 Reference (ADC0REF), DAC0 Reference (DAC0REF) or Analog Comparators (ACREF) registers.

**19.4 Register Summary**

Offset	Name	Bit Pos.	7	6	5	4	3	2	1	0
0x00	ADCOREF	7:0	ALWAYSON						REFSEL[2:0]	
0x01	Reserved									
0x02	DACOREF	7:0	ALWAYSON						REFSEL[2:0]	
0x03	Reserved									
0x04	ACREF	7:0	ALWAYSON						REFSEL[2:0]	

**19.5 Register Description**

## 19.5.1 ADC0 Reference

**Name:** ADC0REF  
**Offset:** 0x00  
**Reset:** 0x00  
**Property:** -

Bit	7	6	5	4	3	2	1	0
	ALWAYSON					REFSEL[2:0]		
Access	R/W					R/W	R/W	R/W
Reset	0					0	0	0

**Bit 7 – ALWAYSON** Reference Always On

This bit controls whether the ADC0 reference is always on or not.

Value	Description
0	The reference is automatically enabled when needed
1	The reference is always on

**Bits 2:0 – REFSEL[2:0]** Reference Select

This bit field controls the reference voltage level for ADC0.

Value	Name	Description
0x0	1V024	Internal 1.024V reference <sup>(1)</sup>
0x1	2V048	Internal 2.048V reference <sup>(1)</sup>
0x2	4V096	Internal 4.096V reference <sup>(1)</sup>
0x3	2V500	Internal 2.500V reference <sup>(1)</sup>
0x4	-	Reserved
0x5	VDD	VDD as reference
0x6	VREFA	External reference from the VREFA pin
0x7	-	Reserved

**Note:**

- The values given for internal references are only typical. Refer to the *Electrical Characteristics* section for further details.

### 19.5.2 DAC0 Reference

**Name:** DAC0REF  
**Offset:** 0x02  
**Reset:** 0x00  
**Property:** -

Bit	7	6	5	4	3	2	1	0
	ALWAYSON					REFSEL[2:0]		
Access	R/W					R/W	R/W	R/W
Reset	0					0	0	0

#### Bit 7 – ALWAYSON Reference Always On

This bit controls whether the DAC0 reference is always on or not.

Value	Description
0	The reference is automatically enabled when needed
1	The reference is always on

#### Bits 2:0 – REFSEL[2:0] Reference Select

This bit field controls the reference voltage level for DAC0.

Value	Name	Description
0x0	1V024	Internal 1.024V reference <sup>(1)</sup>
0x1	2V048	Internal 2.048V reference <sup>(1)</sup>
0x2	4V096	Internal 4.096V reference <sup>(1)</sup>
0x3	2V500	Internal 2.500V reference <sup>(1)</sup>
0x4	-	Reserved
0x5	VDD	VDD as reference
0x6	VREFA	External reference from the VREFA pin
0x7	-	Reserved

#### Note:

- The values given for internal references are only typical. Refer to the *Electrical Characteristics* section for further details.

## 19.5.3 Analog Comparator Reference

**Name:** ACREF  
**Offset:** 0x04  
**Reset:** 0x00  
**Property:** -

Bit	7	6	5	4	3	2	1	0
	ALWAYSON					REFSEL[2:0]		
Access	R/W					R/W	R/W	R/W
Reset	0					0	0	0

**Bit 7 – ALWAYSON** Reference Always On

This bit controls whether the ACs reference is always on or not.

Value	Description
0	The reference is automatically enabled when needed
1	The reference is always on

**Bits 2:0 – REFSEL[2:0]** Reference Select

This bit field controls the reference voltage level for ACs.

Value	Name	Description
0x0	1V024	Internal 1.024V reference <sup>(1)</sup>
0x1	2V048	Internal 2.048V reference <sup>(1)</sup>
0x2	4V096	Internal 4.096V reference <sup>(1)</sup>
0x3	2V500	Internal 2.500V reference <sup>(1)</sup>
0x4	-	Reserved
0x5	VDD	VDD as reference
0x6	VREFA	External reference from the VREFA pin
0x7	-	Reserved

**Note:**

- The values given for internal references are only typical. Refer to the *Electrical Characteristics* section for further details.

## 20. WDT - Watchdog Timer

### 20.1 Features

- Issues a System Reset if the Watchdog Timer is not Cleared Before its Time-out Period
- Operates Asynchronously from the Peripheral Clock Using an Independent Oscillator
- Uses the 1.024 kHz Output of the 32.768 kHz Ultra Low-Power Oscillator (OSC32K)
- 11 Selectable Time-out Periods, from 8 ms to 8s
- Two Operation Modes:
  - Normal mode
  - Window mode
- Configuration Lock to Prevent Unwanted Changes

### 20.2 Overview

The Watchdog Timer (WDT) is a system function for monitoring the correct program operation. When enabled, the WDT is a constantly running timer with a configurable time-out period. If the WDT is not reset within the time-out period, it will issue a system Reset. This allows the system to recover from situations such as runaway or deadlocked code. The WDT is reset by executing the `WDR` (Watchdog Timer Reset) instruction from software.

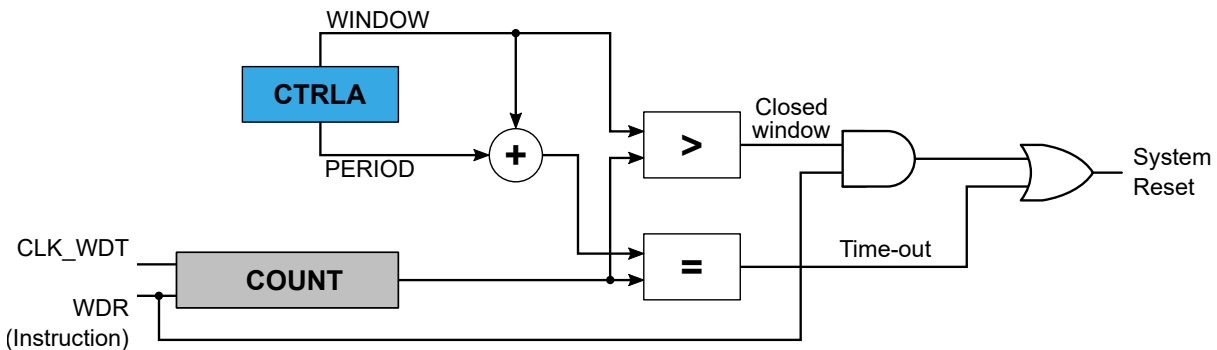
In addition to the Normal mode as described above, the WDT has a Window mode. The Window mode defines a time slot or “window” inside the time-out period during which the WDT must be reset. If the WDT is reset outside this window, either too early or too late, a system Reset will be issued. Compared to the Normal mode, the Window mode can catch situations where a code error causes constant `WDR` execution.

When enabled, the WDT will run in Active mode and all sleep modes. Since it is asynchronous (that is running from a CPU independent clock source), it will continue to operate and be able to issue a system Reset, even if the main clock fails.

The WDT has a Configuration Change Protection (CCP) mechanism and a lock functionality, ensuring the WDT settings cannot be changed by accident.

#### 20.2.1 Block Diagram

Figure 20-1. WDT Block Diagram



### 20.3 Functional Description

#### 20.3.1 Initialization

1. The WDT is enabled when a non-zero value is written to the Period (PERIOD) bit field in the Control A (WDT.CTRLA) register.

- Optional: Write a non-zero value to the Window (WINDOW) bit field in WDT.CTRLA to enable the Window mode operation.

All bits in the Control A register and the Lock (LOCK) bit in the Status (WDT.STATUS) register are write-protected by the Configuration Change Protection (CCP) mechanism.

A fuse (FUSE.WDTCFG) defines the Reset value of the WDT.CTRLA register. If the value of the PERIOD bit field in the FUSE.WDTCFG fuse is different than zero, the WDT is enabled and the LOCK bit in the WDT.STATUS register is set at boot time.

### 20.3.2 Clocks

A 1.024 kHz clock (CLK\_WDT) is sourced from the internal Ultra Low-Power Oscillator, OSC32K. Due to the ultra low-power design, the oscillator is less accurate than other oscillators featured in the device, and hence the exact time-out period may vary from device to device. This variation must be taken into consideration when designing software that uses the WDT, to ensure that the time-out periods used are valid for all devices. Refer to the *Electrical Characteristics* section for more specific information.

The WDT clock (CLK\_WDT) is asynchronous to the peripheral clock. Due to this asynchronicity, writing to the WDT Control A (WDT.CTRLA) register will require synchronization between the clock domains. Refer to [20.3.6 Synchronization](#) for further details.

### 20.3.3 Operation

#### 20.3.3.1 Normal Mode

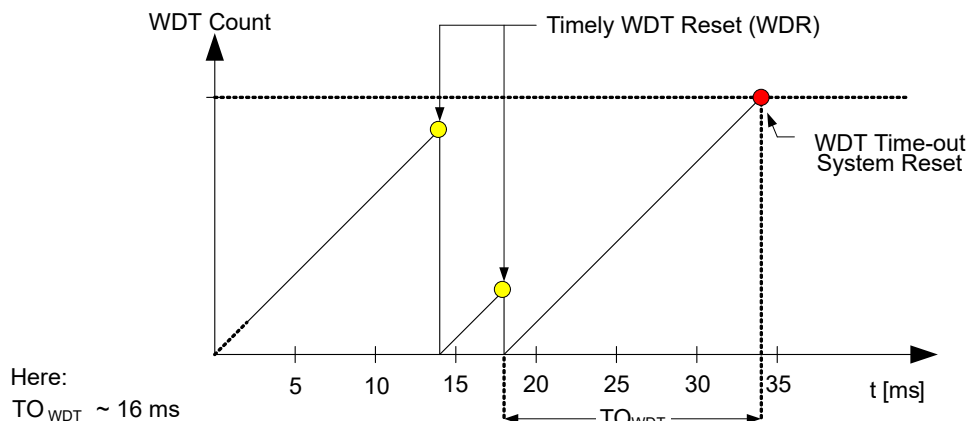
In the Normal mode operation, a single time-out period is set for the WDT. If the WDT is not reset from software using the `WDR` instruction during the defined time-out period, the WDT will issue a system Reset.

A new WDT time-out period starts each time the WDT is reset by software using the `WDR` instruction.

There are 11 possible WDT time-out periods ( $TO_{WDT}$ ), selectable from 8 ms to 8s by writing to the Period (PERIOD) bit field in the Control A (WDT.CTRLA) register.

The figure below shows a typical timing scheme for the WDT operating in Normal mode.

**Figure 20-2. Normal Mode Operation**



The Normal mode is enabled as long as the Window (WINDOW) bit field in the WDT.CTRLA register is '0x0'.

#### 20.3.3.2 Window Mode

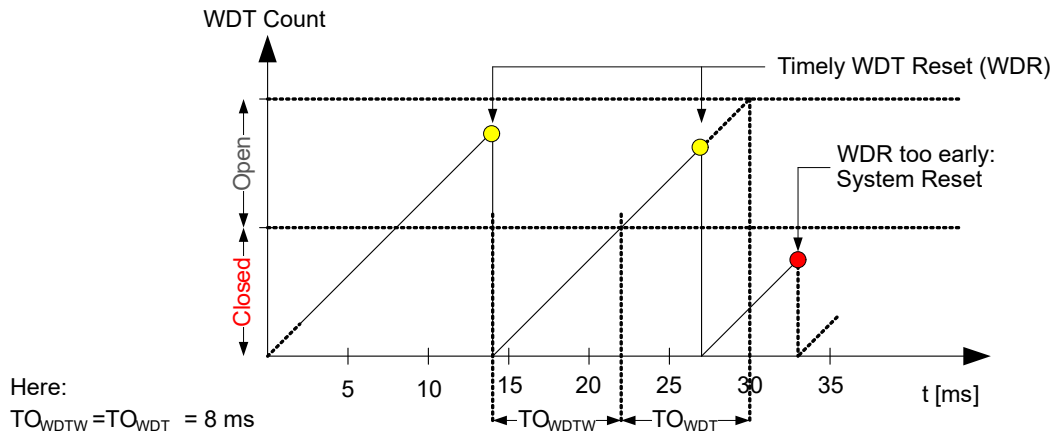
In the Window mode operation, the WDT uses two different time-out periods:

- The closed window time-out period ( $TO_{WDTW}$ ) defines a duration, from 8 ms to 8s, where the WDT cannot be reset. If the WDT is reset during this period, the WDT will issue a system Reset.
- The open window time-out period ( $TO_{WDT}$ ), which is also 8 ms to 8s, defines the duration of the open period during which the WDT can (and needs to) be reset. The open period will always follow the closed period, so the total duration of the time-out period is the sum of the closed window and the open window time-out periods.

When enabling the Window mode or when going out of the Debug mode, the window is activated after the first WDR instruction.

The figure below shows a typical timing scheme for the WDT operating in Window mode.

**Figure 20-3. Window Mode Operation**



The Window mode is enabled by writing a non-zero value to the Window (WINDOW) bit field in the Control A (WDT.CTRLA) register. The Window mode is disabled by writing the WINDOW bit field to '0x0'.

### 20.3.3.3 Preventing Unintentional Changes

The WDT provides two security mechanisms to avoid unintentional changes to the WDT settings:

- The CCP mechanism, employing a timed write procedure for changing the WDT control registers. Refer to [20.3.7 Configuration Change Protection](#) for further details.
- Locking the configuration by writing a '1' to the Lock (LOCK) bit in the Status (WDT.STATUS) register. When this bit is '1', the Control A (WDT.CTRLA) register cannot be changed. The LOCK bit can only be written to '1' in software, while the device needs to be in Debug mode to be able to write it to '0'. Consequently, the WDT cannot be disabled from software.

**Note:** The WDT configuration is loaded from fuses after Reset. If the PERIOD bit field is set to a non-zero value, the LOCK bit is automatically set in WDT.STATUS.

### 20.3.4 Sleep Mode Operation

The WDT will continue to operate in any sleep mode where the source clock is active.

### 20.3.5 Debug Operation

When run-time debugging, this peripheral will continue normal operation. Halting the CPU in Debugging mode will halt the normal operation of the peripheral.

When halting the CPU in Debug mode, the WDT counter is reset.

When starting the CPU and when the WDT is operating in Window mode, the first closed window time-out period will be disabled, and a Normal mode time-out period is executed.

### 20.3.6 Synchronization

The Control A (WDT.CTRLA) register is synchronized when written, due to the asynchronicity between the WDT clock domain and the peripheral clock domain. The Synchronization Busy (SYNCBUSY) flag in the STATUS (WDT.STATUS) register indicates if there is an ongoing synchronization.

Writing to WDT.CTRLA while SYNCBUSY = 1 is not allowed.

The following bit fields must be synchronized when written:

- The Period (PERIOD) bit field in Control A (WDT.CTRLA) register
- The Window (WINDOW) bit field in Control A (WDT.CTRLA) register

The WDR instruction will need two to three cycles of the WDT clock to be synchronized.



### **20.3.7 Configuration Change Protection**

This peripheral has registers that are under Configuration Change Protection (CCP). To write to these registers, a certain key must first be written to the CPU.CCP register, followed by a write access to the protected bits within four CPU instructions.

Attempting to write to a protected register without following the appropriate CCP unlock sequence leaves the protected register unchanged.

The following registers are under CCP:

**Table 20-1. WDT - Registers Under Configuration Change Protection**

<b>Register</b>	<b>Key</b>
WDT.CTRLA	IOREG
LOCK bit in WDT.STATUS	IOREG

20.4 Register Summary

Offset	Name	Bit Pos.	7	6	5	4	3	2	1	0
0x00	<a href="#">CTRLA</a>	7:0	WINDOW[3:0]				PERIOD[3:0]			
0x01	<a href="#">STATUS</a>	7:0	LOCK							SYNCBUSY

20.5 Register Description

### 20.5.1 Control A

**Name:** CTRLA  
**Offset:** 0x00  
**Reset:** From FUSE.WDTCFG  
**Property:** Configuration Change Protection

Bit	7	6	5	4	3	2	1	0
	WINDOW[3:0]				PERIOD[3:0]			
Access	R/W	R/W	R/W	R/W	R/W	R/W	R/W	R/W
Reset	x	x	x	x	x	x	x	x

#### Bits 7:4 – WINDOW[3:0] Window

Writing a non-zero value to these bits enables the Window mode and selects the duration of the closed period accordingly.

The bits are optionally lock-protected:

- If the LOCK bit in WDT.STATUS is '1', all bits are change-protected (Access = R)
- If the LOCK bit in WDT.STATUS is '0', all bits can be changed (Access = R/W)

Value	Name	Description
0x0	OFF	-
0x1	8CLK	7.8125 ms
0x2	16CLK	15.625 ms
0x3	32CLK	31.25 ms
0x4	64CLK	62.5 ms
0x5	128CLK	0.125s
0x6	256CLK	0.250s
0x7	512CLK	0.500s
0x8	1KCLK	1.0s
0x9	2KCLK	2.0s
0xA	4KCLK	4.0s
0xB	8KCLK	8.0s
Other	-	Reserved

**Note:** Refer to the *Electrical Characteristics* section for specific information regarding the accuracy of the 32.768 kHz Ultra Low-Power Oscillator (OSC32K).

#### Bits 3:0 – PERIOD[3:0] Period

Writing a non-zero value to this bit enables the WDT and selects the time-out period in the Normal mode accordingly. In the Window mode, these bits select the duration of the open window.

The bits are optionally lock-protected:

- If the LOCK bit in WDT.STATUS is '1', all bits are change-protected (Access = R)
- If the LOCK bit in WDT.STATUS is '0', all bits can be changed (Access = R/W)

Value	Name	Description
0x0	OFF	-
0x1	8CLK	7.8125 ms
0x2	16CLK	15.625 ms
0x3	32CLK	31.25 ms
0x4	64CLK	62.5 ms
0x5	128CLK	0.125s
0x6	256CLK	0.250s
0x7	512CLK	0.500s
0x8	1KCLK	1.0s
0x9	2KCLK	2.0s
0xA	4KCLK	4.0s

**AVR128DA28/32/48/64**  
**WDT - Watchdog Timer**

---

---

Value	Name	Description
0xB	8KCLK	8.0s
Other	-	Reserved

**Note:** Refer to the *Electrical Characteristics* section for specific information regarding the accuracy of the 32.768 kHz Ultra Low-Power Oscillator (OSC32K).

**20.5.2 Status**

**Name:** STATUS  
**Offset:** 0x01  
**Reset:** 0x00  
**Property:** Configuration Change Protection

Bit	7	6	5	4	3	2	1	0
	LOCK							SYNCBUSY
Access	R/W							R
Reset	0							0

**Bit 7 – LOCK** Lock

Writing this bit to '1' write-protects the WDT.CTRLA register.

It is only possible to write this bit to '1'. This bit can be cleared in Debug mode only.

If the PERIOD bits in WDT.CTRLA are different from zero after boot code, the lock will automatically be set.

This bit is under CCP.

**Bit 0 – SYNCBUSY** Synchronization Busy

This bit is set after writing to the WDT.CTRLA register, while the data is being synchronized from the peripheral clock domain to the WDT clock domain.

This bit is cleared after the synchronization is finished.

This bit is not under CCP.

## 21. TCA - 16-bit Timer/Counter Type A

### 21.1 Features

- 16-Bit Timer/Counter
- Three Compare Channels
- Double-Buffered Timer Period Setting
- Double-Buffered Compare Channels
- Waveform Generation:
  - Frequency generation
  - Single-slope PWM (Pulse-Width Modulation)
  - Dual-slope PWM
- Count on Event
- Timer Overflow Interrupts/Events
- One Compare Match per Compare Channel
- Two 8-Bit Timer/Counters in Split Mode

### 21.2 Overview

The flexible 16-bit PWM Timer/Counter type A (TCA) provides accurate program execution timing, frequency and waveform generation, and command execution.

A TCA consists of a base counter and a set of compare channels. The base counter can be used to count clock cycles or events, or let events control how it counts clock cycles. It has direction control and period setting that can be used for timing. The compare channels can be used together with the base counter to do compare match control, frequency generation, and pulse-width waveform modulation.

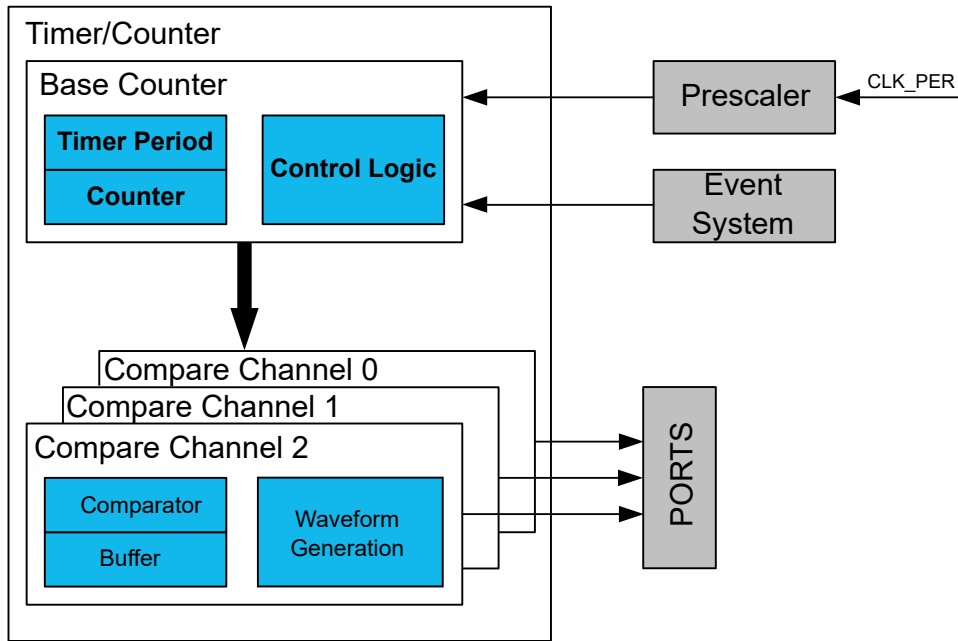
Depending on the mode of operation, the counter is cleared, reloaded, incremented, or decremented at each timer/counter clock or event input.

A timer/counter can be clocked and timed from the peripheral clock, with optional prescaling, or from the Event System. The Event System can also be used for direction control or to synchronize operations.

By default, the TCA is a 16-bit timer/counter. The timer/counter has a Split mode feature that splits it into two 8-bit timer/counters with three compare channels each.

A block diagram of the 16-bit timer/counter with closely related peripheral modules (in grey) is shown in the figure below.

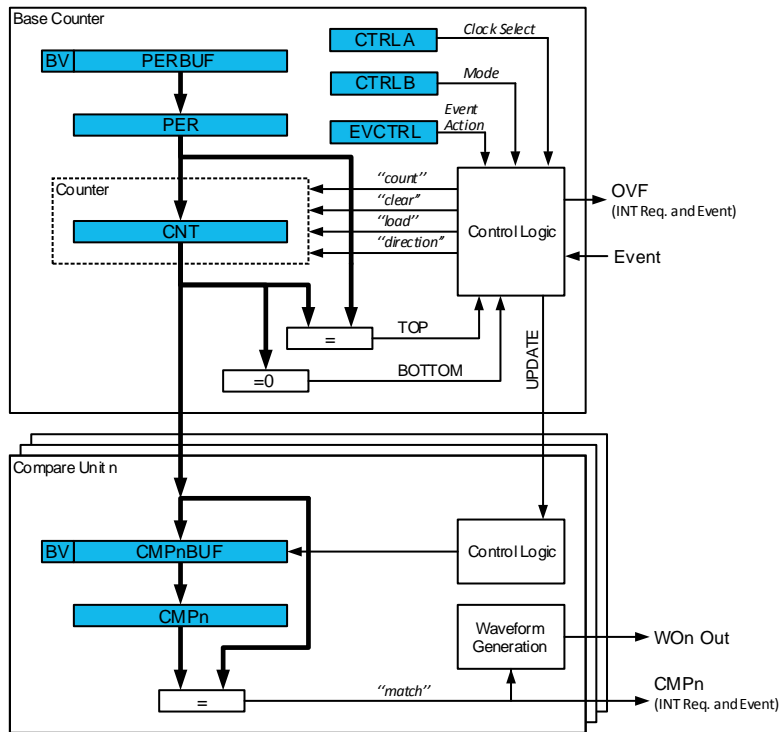
Figure 21-1. 16-bit Timer/Counter and Closely Related Peripherals



21.2.1 Block Diagram

The figure below shows a detailed block diagram of the timer/counter.

Figure 21-2. Timer/Counter Block Diagram



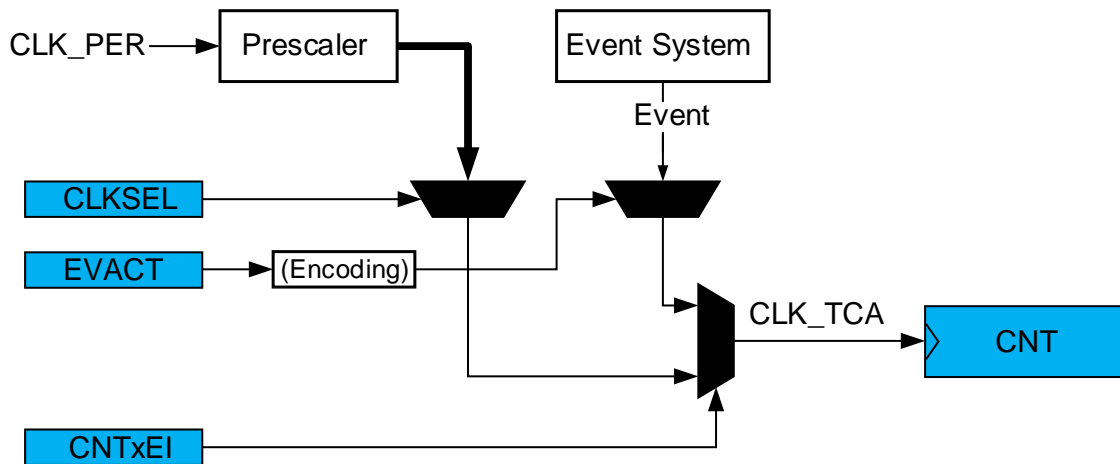
The Counter (TCA<sub>n</sub>.CNT) register, Period and Compare (TCA<sub>n</sub>.PER and TCA<sub>n</sub>.CMP<sub>n</sub>) registers, and their corresponding buffer registers (TCA<sub>n</sub>.PERBUF and TCA<sub>n</sub>.CMP<sub>n</sub>BUF) are 16-bit registers. All buffer registers have a Buffer Valid (BV) flag that indicates when the buffer contains a new value.

During normal operation, the counter value is continuously compared to zero and the period (PER) value to determine whether the counter has reached TOP or BOTTOM. The counter value can also be compared to the TCA<sub>n</sub>.CMP<sub>n</sub> registers.

The timer/counter can generate interrupt requests, events, or change the waveform output after being triggered by the Counter (TCA<sub>n</sub>.CNT) register reaching TOP, BOTTOM, or CMP<sub>n</sub>. The interrupt requests, events, or waveform output changes will occur on the next CLK\_TCA cycle after the triggering.

CLK\_TCA is either the prescaled peripheral clock or events from the Event System, as shown in the figure below.

**Figure 21-3. Timer/Counter Clock Logic**



### 21.2.2 Signal Description

Signal	Description	Type
WOn	Digital output	Waveform output

## 21.3 Functional Description

### 21.3.1 Definitions

The following definitions are used throughout the documentation:

**Table 21-1. Timer/Counter Definitions**

Name	Description
BOTTOM	The counter reaches BOTTOM when it becomes 0x0000.
MAX	The counter reaches MAXimum when it becomes all ones.
TOP	The counter reaches TOP when it becomes equal to the highest value in the count sequence.
UPDATE	The update condition is met when the timer/counter reaches BOTTOM or TOP, depending on the Waveform Generator mode. Buffered registers with valid buffer values will be updated unless the Lock Update (LUPD) bit in the TCA <sub>n</sub> .CTRL <sub>E</sub> register has been set.



.....continued	
Name	Description
CNT	Counter register value.
CMP	Compare register value.
PER	Period register value.

In general, the term timer is used when the timer/counter is counting periodic clock ticks. The term counter is used when the input signal has sporadic or irregular ticks. The latter can be the case when counting events.

### 21.3.2 Initialization

To start using the timer/counter in a basic mode, follow these steps:

1. Write a TOP value to the Period (TCAn.PER) register.
2. Enable the peripheral by writing a '1' to the Enable (ENABLE) bit in the Control A (TCAn.CTRLA) register. The counter will start counting clock ticks according to the prescaler setting in the Clock Select (CLKSEL) bit field in TCAn.CTRLA.
3. Optional: By writing a '1' to the Enable Counter Event Input A (CNTAEI) bit in the Event Control (TCAn.EVCTRL) register, events are counted instead of clock ticks.
4. The counter value can be read from the Counter (CNT) bit field in the Counter (TCAn.CNT) register.

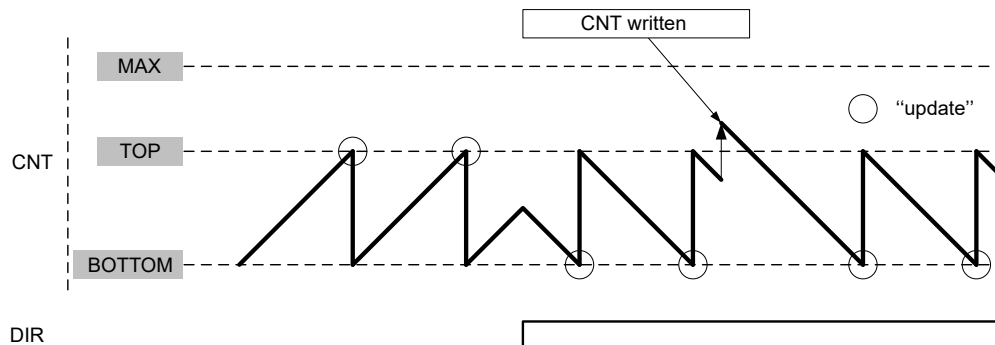
### 21.3.3 Operation

#### 21.3.3.1 Normal Operation

In normal operation, the counter is counting clock ticks in the direction selected by the Direction (DIR) bit in the Control E (TCAn.CTRLE) register, until it reaches TOP or BOTTOM. The clock ticks are given by the peripheral clock (CLK\_PER), prescaled according to the Clock Select (CLKSEL) bit field in the Control A (TCAn.CTRLA) register.

When TOP is reached while the counter is counting up, the counter will wrap to '0' at the next clock tick. When counting down, the counter is reloaded with the Period (TCAn.PER) register value when BOTTOM is reached.

**Figure 21-4. Normal Operation**



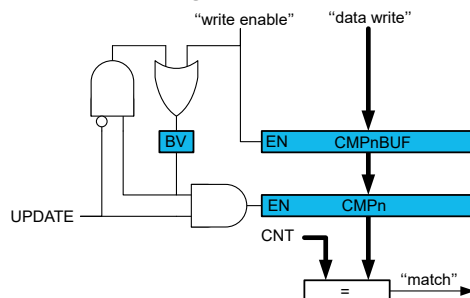
It is possible to change the counter value in the Counter (TCAn.CNT) register when the counter is running. The write access to TCAn.CNT has higher priority than count, clear or reload, and will be immediate. The direction of the counter can also be changed during normal operation by writing to DIR in TCAn.CTRLE.

#### 21.3.3.2 Double Buffering

The Period (TCAn.PER) register value and the Compare n (TCAn.CMPn) register values are all double-buffered (TCAn.PERBUF and TCAn.CMPnBUF).

Each buffer register has a Buffer Valid (BV) flag (PERBV, CMPnBV) in the Control F (TCAn.CTRLF) register, which indicates that the buffer register contains a valid (new) value that can be copied into the corresponding Period or Compare register. When the Period register and Compare n registers are used for a compare operation, the BV flag is set when data are written to the buffer register and cleared on an UPDATE condition. This is shown for a Compare (CMPn) register in the figure below.

Figure 21-5. Period and Compare Double Buffering



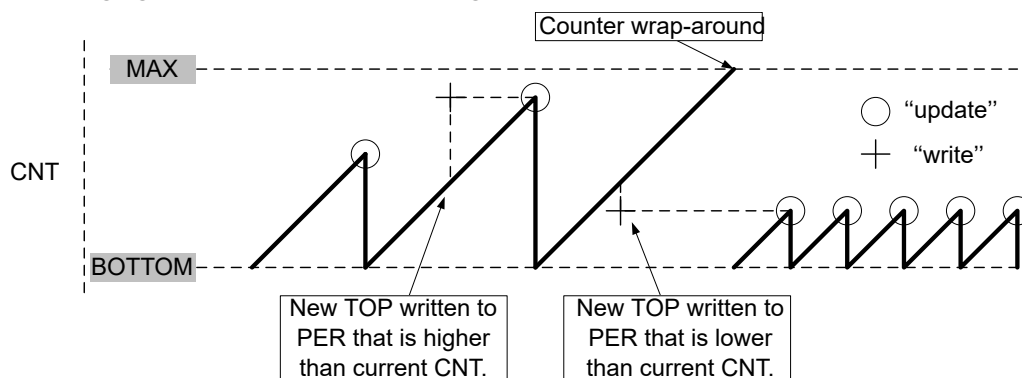
Both the TCA<sub>n</sub>.CMP<sub>n</sub> and TCA<sub>n</sub>.CMP<sub>n</sub>BUF registers are available as I/O registers. This allows initialization and bypassing of the buffer register and the double-buffering function.

### 21.3.3.3 Changing the Period

The Counter period is changed by writing a new TOP value to the Period (TCA<sub>n</sub>.PER) register.

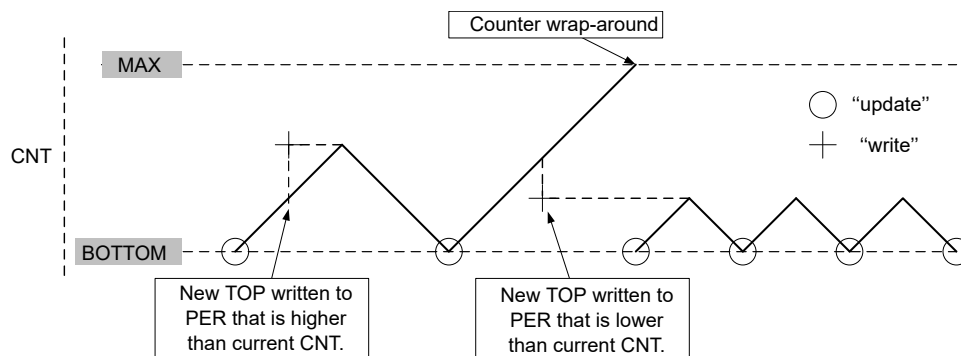
**No Buffering:** If double-buffering is not used, any period update is immediate.

Figure 21-6. Changing the Period Without Buffering



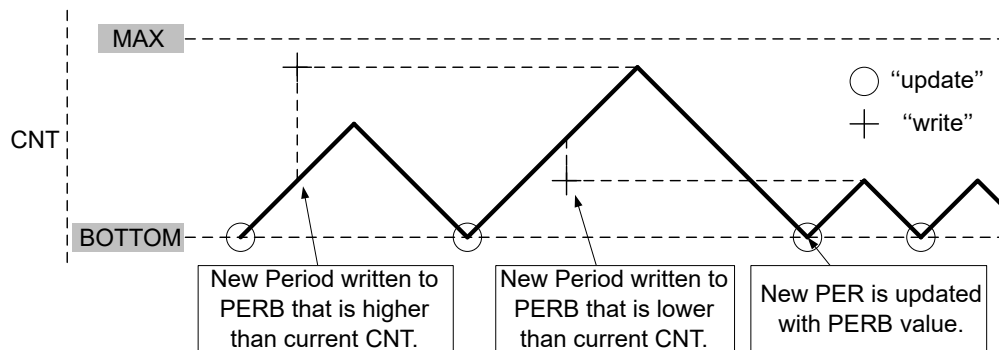
A counter wrap-around can occur in any mode of operation when counting up without buffering, as the TCA<sub>n</sub>.CNT and TCA<sub>n</sub>.PER registers are continuously compared. If a new TOP value is written to TCA<sub>n</sub>.PER that is lower than the current TCA<sub>n</sub>.CNT, the counter will wrap first, before a compare match occurs.

Figure 21-7. Unbuffered Dual-Slope Operation



**With Buffering:** When double-buffering is used, the buffer can be written at any time and still maintain correct operation. The TCA<sub>n</sub>.PER is always updated on the UPDATE condition, as shown for dual-slope operation in the figure below. This prevents wrap-around and the generation of odd waveforms.

Figure 21-8. Changing the Period Using Buffering



**Note:** Buffering is used in figures illustrating TCA operation if not otherwise specified.

### 21.3.3.4 Compare Channel

Each Compare Channel *n* continuously compares the counter value (TCA<sub>n</sub>.CNT) with the Compare *n* (TCA<sub>n</sub>.CMP<sub>n</sub>) register. If TCA<sub>n</sub>.CNT equals TCA<sub>n</sub>.CMP<sub>n</sub>, the Comparator *n* signals a match. The match will set the Compare Channel's interrupt flag at the next timer clock cycle, and the optional interrupt is generated.

The Compare *n* Buffer (TCA<sub>n</sub>.CMP<sub>n</sub>BUF) register provides double-buffer capability equivalent to that for the period buffer. The double-buffering synchronizes the update of the TCA<sub>n</sub>.CMP<sub>n</sub> register with the buffer value to either the TOP or BOTTOM of the counting sequence, according to the UPDATE condition. The synchronization prevents the occurrence of odd-length, non-symmetrical pulses for glitch-free output.

The value in CMP<sub>n</sub>BUF is moved to CMP<sub>n</sub> at the UPDATE condition and is compared to the counter value (TCA<sub>n</sub>.CNT) from the next count.

#### 21.3.3.4.1 Waveform Generation

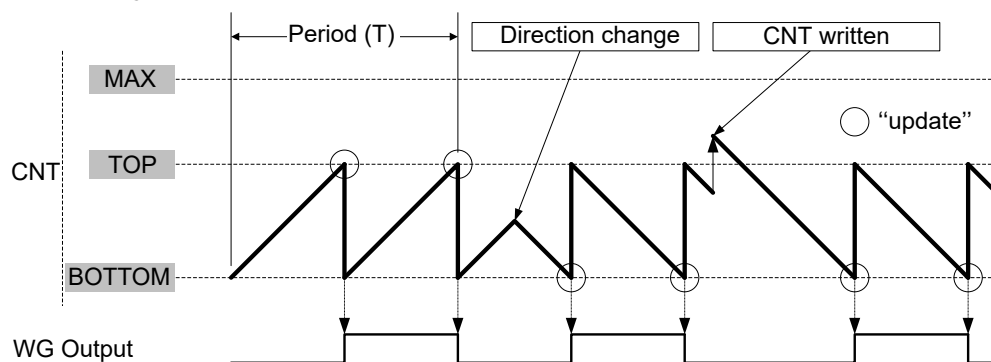
The compare channels can be used for waveform generation on the corresponding port pins. The following requirements must be met to make the waveform visible on the connected port pin:

1. A Waveform Generation mode must be selected by writing the Waveform Generation Mode (WGMODE) bit field in the TCA<sub>n</sub>.CTRLB register.
2. The compare channels used must be enabled (CMP<sub>n</sub>EN = 1 in TCA<sub>n</sub>.CTRLB). This will override the output value for the corresponding pin. An alternative pin can be selected by configuring the Port Multiplexer (PORTMUX). Refer to the *PORTMUX* section for details.
3. The direction for the associated port pin *n* must be configured in the Port peripheral as an output.
4. Optional: Enable the inverted waveform output for the associated port pin *n*. Refer to the *PORT* section for details.

#### 21.3.3.4.2 Frequency (FRQ) Waveform Generation

For frequency generation, the period time (*T*) is controlled by the TCA<sub>n</sub>.CMP0 register instead of the Period (TCA<sub>n</sub>.PER) register. The corresponding waveform generator output is toggled on each compare match between the TCA<sub>n</sub>.CNT and TCA<sub>n</sub>.CMP<sub>n</sub> registers.

Figure 21-9. Frequency Waveform Generation



The waveform frequency ( $f_{FRQ}$ ) is defined by the following equation:

$$f_{FRQ} = \frac{f_{CLK\_PER}}{2N(CMPn+1)}$$

where  $N$  represents the prescaler divider used (see the CLKSEL bit field in the TCA $n$ .CTRLA register), and  $f_{CLK\_PER}$  is the peripheral clock frequency.

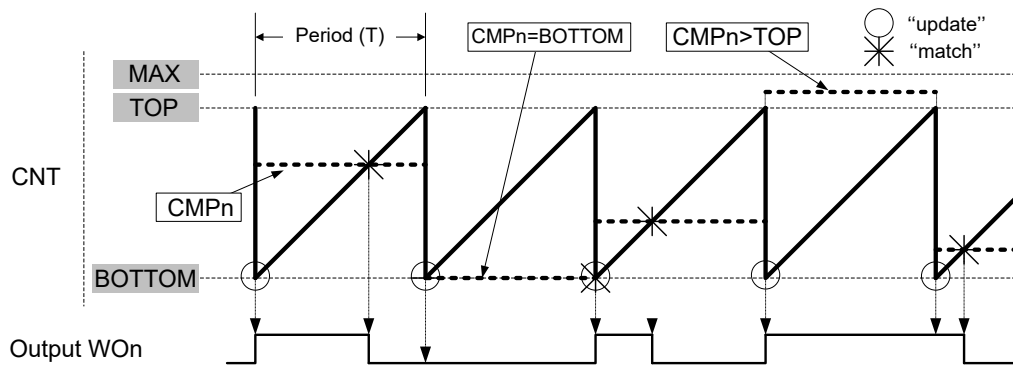
The maximum frequency of the waveform generated is half of the peripheral clock frequency ( $f_{CLK\_PER}/2$ ) when TCA $n$ .CMP0 is written to 0x0000 and no prescaling is used ( $N = 1$ , CLKSEL = 0x0 in TCA $n$ .CTRLA).

#### 21.3.3.4.3 Single-Slope PWM Generation

For single-slope Pulse-Width Modulation (PWM) generation the period ( $T$ ) is controlled by the TCA $n$ .PER register, while the values of the TCA $n$ .CMP $n$  registers control the duty cycles of the generated waveforms. The figure below shows how the counter counts from BOTTOM to TOP and then restarts from BOTTOM. The waveform generator output is set at BOTTOM and cleared on the compare match between the TCA $n$ .CNT and TCA $n$ .CMP $n$  registers.

CMP $n$  = BOTTOM will produce a static low signal on WOn while CMP $n$  > TOP will produce a static high signal on WOn.

**Figure 21-10. Single-Slope Pulse-Width Modulation**



**Note:** The representation in the figure above is valid for when CMP $n$  is updated using CMPnBUF.

The TCA $n$ .PER register defines the PWM resolution. The minimum resolution is 2 bits (TCA $n$ .PER = 0x0002), and the maximum resolution is 16 bits (TCA $n$ .PER = MAX-1).

The following equation calculates the exact resolution in bits for single-slope PWM ( $R_{PWM\_SS}$ ):

$$R_{PWM\_SS} = \frac{\log(PER+2)}{\log(2)}$$

The single-slope PWM frequency ( $f_{PWM\_SS}$ ) depends on the period setting (TCA $n$ .PER), the peripheral clock frequency  $f_{CLK\_PER}$  and the TCA prescaler (the CLKSEL bit field in the TCA $n$ .CTRLA register). It is calculated by the following equation where  $N$  represents the prescaler divider used:

$$f_{PWM\_SS} = \frac{f_{CLK\_PER}}{N(PER+1)}$$

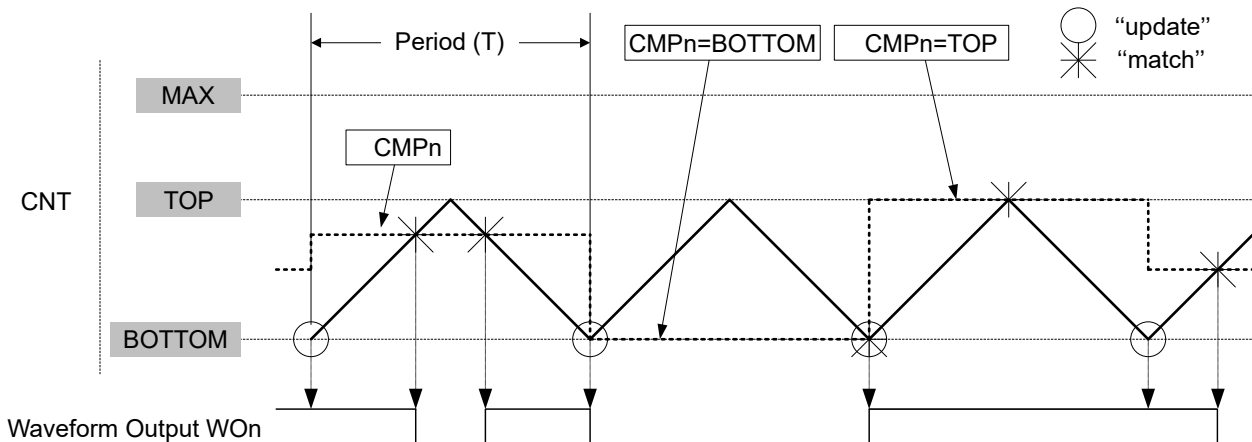
#### 21.3.3.4.4 Dual-Slope PWM

For dual-slope PWM generation, the period ( $T$ ) is controlled by TCA $n$ .PER, while the values of TCA $n$ .CMP $n$  control the duty cycle of the WG output.

The figure below shows how, for dual-slope PWM, the counter counts repeatedly from BOTTOM to TOP and then from TOP to BOTTOM. The waveform generator output is set at BOTTOM, cleared on compare match when up-counting and set on compare match when down-counting.

CMP $n$  = BOTTOM will produce a static low signal on WOn, while CMP $n$  = TOP will produce a static high signal on WOn.

Figure 21-11. Dual-Slope Pulse-Width Modulation



**Note:** The representation in the figure above is valid for when CMPn is updated using CMPnBUF.

Using dual-slope PWM results in half the maximum operation frequency compared to single-slope PWM operation, due to twice the number of timer increments per period.

The Period (TCA<sub>n</sub>.PER) register defines the PWM resolution. The minimum resolution is 2 bits (TCA<sub>n</sub>.PER = 0x0003), and the maximum resolution is 16 bits (TCA<sub>n</sub>.PER = MAX).

The following equation calculates the exact resolution in bits for dual-slope PWM ( $R_{PWM\_DS}$ ):

$$R_{PWM\_DS} = \frac{\log(PER+1)}{\log(2)}$$

The PWM frequency depends on the period setting in the TCA<sub>n</sub>.PER register, the peripheral clock frequency ( $f_{CLK\_PER}$ ) and the prescaler divider selected in the CLKSEL bit field in the TCA<sub>n</sub>.CTRLA register. It is calculated by the following equation:

$$f_{PWM\_DS} = \frac{f_{CLK\_PER}}{2N \cdot PER}$$

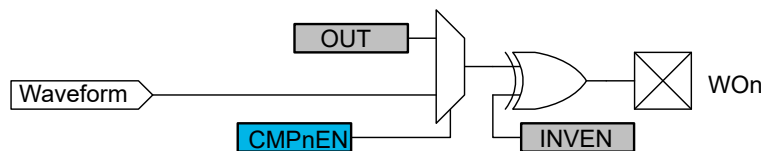
$N$  represents the prescaler divider used.

#### 21.3.3.4.5 Port Override for Waveform Generation

To make the waveform generation available on the port pins, the corresponding port pin direction must be set as output (PORT<sub>x</sub>.DIR[n] = 1). The TCA will override the port pin values when the compare channel is enabled (CMPnEN = 1 in TCA<sub>n</sub>.CTRLB) and a Waveform Generation mode is selected.

The figure below shows the port override for TCA. The timer/counter compare channel will override the port pin output value (OUT) on the corresponding port pin. Enabling inverted I/O on the port pin (INVEN = 1 in PORT.PINn) inverts the corresponding WG output.

Figure 21-12. Port Override for Timer/Counter Type A



#### 21.3.3.5 Timer/Counter Commands

A set of commands can be issued by software to immediately change the state of the peripheral. These commands give direct control of the UPDATE, RESTART and RESET signals. A command is issued by writing the respective value to the Command (CMD) bit field in the Control E (TCA<sub>n</sub>.CTRLESET) register.

An UPDATE command has the same effect as when an UPDATE condition occurs, except that the UPDATE command is not affected by the state of the Lock Update (LUPD) bit in the Control E (TCA<sub>n</sub>.CTRLE) register.

The software can force a restart of the current waveform period by issuing a RESTART command. In this case, the counter, direction, and all compare outputs are set to '0'.

A RESET command will set all timer/counter registers to their initial values. A RESET command can be issued only when the timer/counter is not running (ENABLE = 0 in the TCAn.CTRLA register).

### 21.3.3.6 Split Mode - Two 8-Bit Timer/Counters

#### Split Mode Overview

To double the number of timers and PWM channels in the TCA, a Split mode is provided. In this Split mode, the 16-bit timer/counter acts as two separate 8-bit timers, which each have three compare channels for PWM generation. The Split mode will only work with single-slope down-count. Event controlled operation is not supported in Split mode.

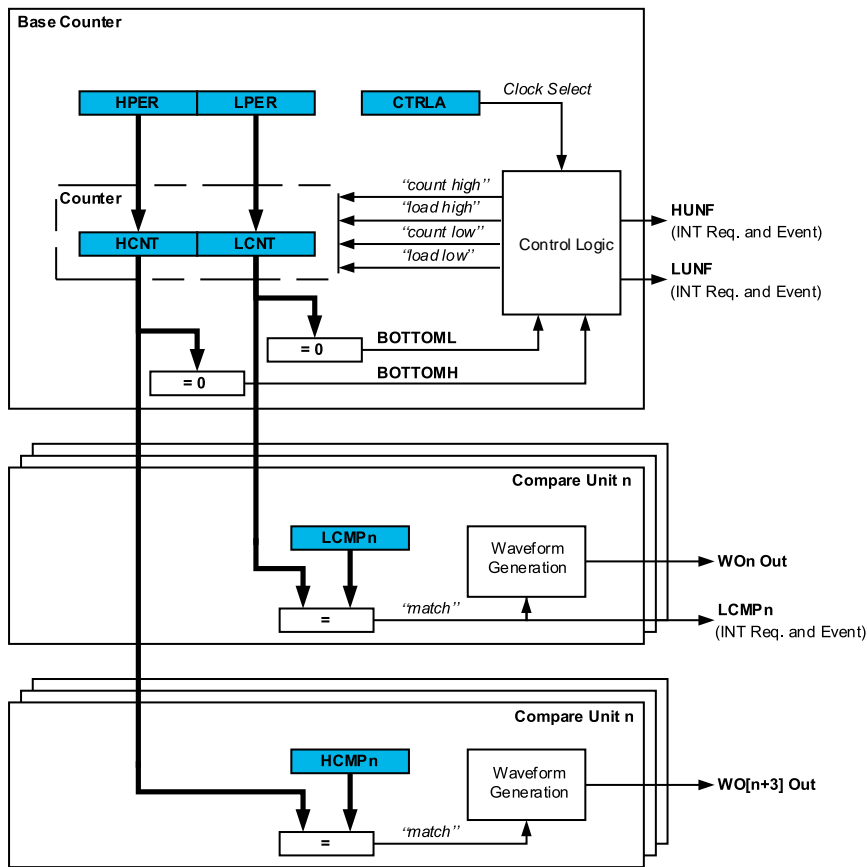
Activating Split mode results in changes to the functionality of some registers and register bits. The modifications are described in a separate register map (see [21.6 Register Summary - Split Mode](#)).

#### Split Mode Differences Compared to Normal Mode

- Count:
  - Down-count only
  - Low Byte Timer Counter (TCAn.LCNT) register and High Byte Timer Counter (TCAn.HCNT) register are independent
- Waveform Generation:
  - Single-slope PWM only (WGMODE = SINGLESLOPE in TCAn.CTRLB)
- Interrupt:
  - No change for Low Byte Timer Counter (TCAn.LCNT) register
  - Underflow interrupt for High Byte Timer Counter (TCAn.HCNT) register
  - No compare interrupt or flag for High Byte Compare n (TCAn.HCMPn) register
- Event Actions: Not Compatible
- Buffer Registers and Buffer Valid Flags: Unused
- Register Access: Byte Access to All Registers

Block Diagram

Figure 21-13. Timer/Counter Block Diagram Split Mode



**Split Mode Initialization**

When shifting between Normal mode and Split mode, the functionality of some registers and bits changes, but their values do not. For this reason, disabling the peripheral (ENABLE = 0 in TCAn.CTRLA) and doing a hard Reset (CMD = RESET in TCAn.CTRLESET) is recommended when changing the mode to avoid unexpected behavior.

To start using the timer/counter in basic Split mode after a hard Reset, follow these steps:

1. Enable Split mode by writing a '1' to the Split mode enable (SPLITM) bit in the Control D (TCAn.CTRLD) register.
2. Write a TOP value to the Period (TCAn.PER) registers.
3. Enable the peripheral by writing a '1' to the Enable (ENABLE) bit in the Control A (TCAn.CTRLA) register. The counter will start counting clock ticks according to the prescaler setting in the Clock Select (CLKSEL) bit field in the TCAn.CTRLA register.
4. The counter values can be read from the Counter bit field in the Counter (TCAn.CNT) registers.

**21.3.4 Events**

The TCA can generate the events described in the table below. All event generators except TCAn\_HUNF are shared between Normal mode and Split mode operation, and the generator name indicates what specific signal the generator represents in each mode in the following way: OVF\_LUNF corresponds to overflow in Normal mode and Low byte timer underflow in Split mode. The same applies to CMPn\_LCMPn.

**Table 21-2. Event Generators in TCA**

Generator Name		Description	Event Type	Generating Clock Domain	Length of Event
Peripheral	Event				
TCA <sub>n</sub>	OVF_LUNF	Normal mode: Overflow Split mode: Low byte timer underflow	Pulse	CLK_PER	One CLK_PER period
	HUNF	Normal mode: Not available Split mode: High byte timer underflow	Pulse	CLK_PER	One CLK_PER period
	CMP0_LCMP0	Normal mode: Compare Channel 0 match Split mode: Low byte timer Compare Channel 0 match	Pulse	CLK_PER	One CLK_PER period
	CMP1_LCMP1	Normal mode: Compare Channel 1 match Split mode: Low byte timer Compare Channel 1 match	Pulse	CLK_PER	One CLK_PER period
	CMP2_LCMP2	Normal mode: Compare Channel 2 match Split mode: Low byte timer Compare Channel 2 match	Pulse	CLK_PER	One CLK_PER period

The conditions for generating an event are identical to those that will raise the corresponding interrupt flag in the TCA<sub>n</sub>.INTFLAGS register for both Normal mode and Split mode.

The TCA has two event users for detecting and acting upon input events. The table below describes the event users and their associated functionality.

**Table 21-3. Event Users in TCA**

User Name		Description	Input Detection	Async/Sync
Peripheral	Input			
TCA <sub>n</sub>	CNTA	Count on a positive event edge	Edge	Sync
		Count on any event edge	Edge	Sync
		Count while the event signal is high	Level	Sync
		The event level controls the count direction, up when low and down when high	Level	Sync
	CNTB	The event level controls count direction, up when low and down when high	Level	Sync
		Restart counter on a positive event edge	Edge	Sync
		Restart counter on any event edge	Edge	Sync
		Restart counter while the event signal is high	Level	Sync

The specific actions described in the table above are selected by writing to the Event Action (EVACTA, EVACTB) bits in the Event Control (TCA<sub>n</sub>.EVCTRL) register. Input events are enabled by writing a '1' to the Enable Counter Event Input (CNTAEI and CNTBEI) bits in the TCA<sub>n</sub>.EVCTRL register.



If both EVACTA and EVACTB are configured to control the count direction, the event signals will be OR'ed to determine the count direction. Both event inputs must then be low for the counter to count upwards.

Event inputs are not used in Split mode.

Refer to the *Event System (EVSYS)* section for more details regarding event types and Event System configuration.

### 21.3.5 Interrupts

**Table 21-4. Available Interrupt Vectors and Sources in Normal Mode**

Name	Vector Description	Conditions
OVF	Overflow or underflow interrupt	The counter has reached TOP or BOTTOM
CMP0	Compare Channel 0 interrupt	Match between the counter value and the Compare 0 register
CMP1	Compare Channel 1 interrupt	Match between the counter value and the Compare 1 register
CMP2	Compare Channel 2 interrupt	Match between the counter value and the Compare 2 register

**Table 21-5. Available Interrupt Vectors and Sources in Split Mode**

Name	Vector Description	Conditions
LUNF	Low-byte Underflow interrupt	Low byte timer reaches BOTTOM
HUNF	High-byte Underflow interrupt	High byte timer reaches BOTTOM
LCMP0	Compare Channel 0 interrupt	Match between the counter value and the low byte of the Compare 0 register
LCMP1	Compare Channel 1 interrupt	Match between the counter value and the low byte of the Compare 1 register
LCMP2	Compare Channel 2 interrupt	Match between the counter value and the low byte of the Compare 2 register

When an interrupt condition occurs, the corresponding interrupt flag is set in the peripheral's Interrupt Flags (*peripheral.INTFLAGS*) register.

An interrupt source is enabled or disabled by writing to the corresponding enable bit in the peripheral's Interrupt Control (*peripheral.INTCTRL*) register.

An interrupt request is generated when the corresponding interrupt source is enabled, and the interrupt flag is set. The interrupt request remains active until the interrupt flag is cleared. See the peripheral's INTFLAGS register for details on how to clear interrupt flags.

### 21.3.6 Sleep Mode Operation

TCA is by default disabled in Standby sleep mode. It will be halted as soon as the sleep mode is entered.

The module can stay fully operational in Standby sleep mode if the Run Standby (RUNSTDBY) bit in the TCA<sub>n</sub>.CTRLA register is written to '1'.

All operation is halted in Power-Down sleep mode.

## 21.4 Register Summary - Normal Mode

Offset	Name	Bit Pos.	7	6	5	4	3	2	1	0
0x00	CTRLA	7:0	RUNSTDBY					CLKSEL[2:0]		ENABLE
0x01	CTRLB	7:0		CMP2EN	CMP1EN	CMP0EN	ALUPD	WGMODE[2:0]		
0x02	CTRLC	7:0						CMP2OV	CMP1OV	CMP0OV
0x03	CTRLD	7:0								SPLITM
0x04	CTRLECLR	7:0					CMD[1:0]		LUPD	DIR
0x05	CTRLESET	7:0					CMD[1:0]		LUPD	DIR
0x06	CTRLFCLR	7:0					CMP2BV	CMP1BV	CMP0BV	PERBV
0x07	CTRLFSET	7:0					CMP2BV	CMP1BV	CMP0BV	PERBV
0x08	Reserved									
0x09	EVCTRL	7:0		EVACTB[2:0]		CNTBEI	EVACTA[2:0]			CNTAEI
0x0A	INTCTRL	7:0		CMP2	CMP1	CMP0				OVF
0x0B	INTFLAGS	7:0		CMP2	CMP1	CMP0				OVF
0x0C	Reserved									
...	Reserved									
0x0D	Reserved									
0x0E	DBGCTRL	7:0								DBGRUN
0x0F	TEMP	7:0	TEMP[7:0]							
0x10	Reserved									
...	Reserved									
0x1F	Reserved									
0x20	CNT	7:0	CNT[7:0]							
		15:8	CNT[15:8]							
0x22	Reserved									
...	Reserved									
0x25	Reserved									
0x26	PER	7:0	PER[7:0]							
		15:8	PER[15:8]							
0x28	CMP0	7:0	CMP[7:0]							
		15:8	CMP[15:8]							
0x2A	CMP1	7:0	CMP[7:0]							
		15:8	CMP[15:8]							
0x2C	CMP2	7:0	CMP[7:0]							
		15:8	CMP[15:8]							
0x2E	Reserved									
...	Reserved									
0x35	Reserved									
0x36	PERBUF	7:0	PERBUF[7:0]							
		15:8	PERBUF[15:8]							
0x38	CMP0BUF	7:0	CMPBUF[7:0]							
		15:8	CMPBUF[15:8]							
0x3A	CMP1BUF	7:0	CMPBUF[7:0]							
		15:8	CMPBUF[15:8]							
0x3C	CMP2BUF	7:0	CMPBUF[7:0]							
		15:8	CMPBUF[15:8]							

## 21.5 Register Description - Normal Mode

### 21.5.1 Control A

**Name:** CTRLA  
**Offset:** 0x00  
**Reset:** 0x00  
**Property:** -

	7	6	5	4	3	2	1	0
	RUNSTDBY					CLKSEL[2:0]		ENABLE
Access	R/W				R/W	R/W	R/W	R/W
Reset	0				0	0	0	0

**Bit 7 – RUNSTDBY** Run Standby

Writing a '1' to this bit will enable the peripheral to run in Standby sleep mode.

**Bits 3:1 – CLKSEL[2:0]** Clock Select

These bits select the clock frequency for the timer/counter.

Value	Name	Description
0x0	DIV1	$f_{TCA} = f_{CLK\_PER}$
0x1	DIV2	$f_{TCA} = f_{CLK\_PER}/2$
0x2	DIV4	$f_{TCA} = f_{CLK\_PER}/4$
0x3	DIV8	$f_{TCA} = f_{CLK\_PER}/8$
0x4	DIV16	$f_{TCA} = f_{CLK\_PER}/16$
0x5	DIV64	$f_{TCA} = f_{CLK\_PER}/64$
0x6	DIV256	$f_{TCA} = f_{CLK\_PER}/256$
0x7	DIV1024	$f_{TCA} = f_{CLK\_PER}/1024$

**Bit 0 – ENABLE** Enable

Value	Description
0	The peripheral is disabled
1	The peripheral is enabled

### 21.5.2 Control B - Normal Mode

**Name:** CTRLB  
**Offset:** 0x01  
**Reset:** 0x00  
**Property:** -

Bit	7	6	5	4	3	2	1	0
		CMP2EN	CMP1EN	CMP0EN	ALUPD	WGMODE[2:0]		
Access		R/W	R/W	R/W	R/W	R/W	R/W	R/W
Reset		0	0	0	0	0	0	0

#### Bits 4, 5, 6 – CMPEN Compare n Enable

In the FRQ and PWM Waveform Generation modes the Compare n Enable (CMPnEN) bits will make the waveform output available on the pin corresponding to WOn, overriding the value in the corresponding PORT output register. The corresponding pin direction must be configured as an output in the PORT peripheral.

Value	Description
0	Waveform output WOn will not be available on the corresponding pin
1	Waveform output WOn will override the output value of the corresponding pin

#### Bit 3 – ALUPD Auto-Lock Update

The Auto-Lock Update bit controls the Lock Update (LUPD) bit in the TCA.CTRLE register. When ALUPD is written to '1', LUPD will be set to '1' until the Buffer Valid (CMPnBV) bits of all enabled compare channels are '1'. This condition will clear LUPD.

It will remain cleared until the next UPDATE condition, where the buffer values will be transferred to the CMPn registers and LUPD will be set to '1' again. This makes sure that the CMPnBUF register values are not transferred to the CMPn registers until all enabled compare buffers are written.

Value	Description
0	LUPD in TCA.CTRLE is not altered by the system
1	LUPD in TCA.CTRLE is set and cleared automatically

#### Bits 2:0 – WGMODE[2:0] Waveform Generation Mode

These bits select the Waveform Generation mode and control the counting sequence of the counter, TOP value, UPDATE condition, Interrupt condition, and the type of waveform generated.

No waveform generation is performed in the Normal mode of operation. For all other modes, the waveform generator output will only be directed to the port pins if the corresponding CMPnEN bit has been set. The port pin direction must be set as output.

**Table 21-6. Timer Waveform Generation Mode**

Value	Group Configuration	Mode of Operation	TOP	UPDATE	OVF
0x0	NORMAL	Normal	PER	TOP <sup>(1)</sup>	TOP <sup>(1)</sup>
0x1	FRQ	Frequency	CMP0	TOP <sup>(1)</sup>	TOP <sup>(1)</sup>
0x2	-	Reserved	-	-	-
0x3	SINGLESLOPE	Single-slope PWM	PER	BOTTOM	BOTTOM
0x4	-	Reserved	-	-	-
0x5	DSTOP	Dual-slope PWM	PER	BOTTOM	TOP
0x6	DSBOTH	Dual-slope PWM	PER	BOTTOM	TOP and BOTTOM
0x7	DSBOTTOM	Dual-slope PWM	PER	BOTTOM	BOTTOM

**Note:**

1. When counting up.

**21.5.3 Control C - Normal Mode**

**Name:** CTRLC  
**Offset:** 0x02  
**Reset:** 0x00  
**Property:** -

	7	6	5	4	3	2	1	0
Access						CMP2OV	CMP1OV	CMP0OV
Reset						R/W	R/W	R/W
						0	0	0

**Bit 2 – CMP2OV** Compare Output Value 2  
 See CMP0OV.

**Bit 1 – CMP1OV** Compare Output Value 1  
 See CMP0OV.

**Bit 0 – CMP0OV** Compare Output Value 0  
 The CMPnOV bits allow direct access to the waveform generator’s output compare value when the timer/counter is not enabled. This is used to set or clear the WG output value when the timer/counter is not running.

21.5.4 Control D

Name: CTRLD  
Offset: 0x03  
Reset: 0x00  
Property: -

Bit	7	6	5	4	3	2	1	0
Access								SPLITM
Reset								0

**Bit 0 – SPLITM** Enable Split Mode

This bit sets the timer/counter in Split mode operation. It will then work as two 8-bit timer/counters. The register map will change compared to normal 16-bit mode.

### 21.5.5 Control Register E Clear - Normal Mode

**Name:** CTRLECLR  
**Offset:** 0x04  
**Reset:** 0x00  
**Property:** -

This register can be used instead of a Read-Modify-Write (RMW) to clear individual bits by writing a '1' to its bit location.

	7	6	5	4	3	2	1	0
					CMD[1:0]		LUPD	DIR
Access					R/W	R/W	R/W	R/W
Reset					0	0	0	0

#### Bits 3:2 – CMD[1:0] Command

These bits are used for software control of update, restart and Reset of the timer/counter. The command bits are always read as '0'.

Value	Name	Description
0x0	NONE	No command
0x1	UPDATE	Force update
0x2	RESTART	Force restart
0x3	RESET	Force hard Reset (ignored if the timer/counter is enabled)

#### Bit 1 – LUPD Lock Update

Lock update can be used to ensure that all buffers are valid before an update is performed.

Value	Description
0	The buffered registers are updated as soon as an UPDATE condition has occurred
1	No update of the buffered registers is performed, even though an UPDATE condition has occurred

#### Bit 0 – DIR Counter Direction

Normally this bit is controlled in hardware by the Waveform Generation mode or by event actions, but it can also be changed from software.

Value	Description
0	The counter is counting up (incrementing)
1	The counter is counting down (decrementing)

### 21.5.6 Control Register E Set - Normal Mode

**Name:** CTRLSET  
**Offset:** 0x05  
**Reset:** 0x00  
**Property:** -

This register can be used instead of a Read-Modify-Write (RMW) to set individual bits by writing a '1' to its bit location.

	7	6	5	4	3	2	1	0
					CMD[1:0]		LUPD	DIR
Access					R/W	R/W	R/W	R/W
Reset					0	0	0	0

#### Bits 3:2 – CMD[1:0] Command

These bits are used for software control of update, restart and Reset the timer/counter. The command bits are always read as '0'.

Value	Name	Description
0x0	NONE	No command
0x1	UPDATE	Force update
0x2	RESTART	Force restart
0x3	RESET	Force hard Reset (ignored if the timer/counter is enabled)

#### Bit 1 – LUPD Lock Update

Locking the update ensures that all buffers are valid before an update is performed.

Value	Description
0	The buffered registers are updated as soon as an UPDATE condition has occurred
1	No update of the buffered registers is performed, even though an UPDATE condition has occurred

#### Bit 0 – DIR Counter Direction

Normally this bit is controlled in hardware by the Waveform Generation mode or by event actions, but it can also be changed from software.

Value	Description
0	The counter is counting up (incrementing)
1	The counter is counting down (decrementing)



### 21.5.7 Control Register F Clear

**Name:** CTRLFCLR  
**Offset:** 0x06  
**Reset:** 0x00  
**Property:** -

This register can be used instead of a Read-Modify-Write (RMW) to clear individual bits by writing a '1' to its bit location.

	7	6	5	4	3	2	1	0
					CMP2BV	CMP1BV	CMP0BV	PERBV
Access					R/W	R/W	R/W	R/W
Reset					0	0	0	0

**Bit 3 – CMP2BV** Compare 2 Buffer Valid  
 See CMP0BV.

**Bit 2 – CMP1BV** Compare 1 Buffer Valid  
 See CMP0BV.

**Bit 1 – CMP0BV** Compare 0 Buffer Valid  
 The CMPnBV bits are set when a new value is written to the corresponding TCAn.CMPnBUF register. These bits are automatically cleared on an UPDATE condition.

**Bit 0 – PERBV** Period Buffer Valid  
 This bit is set when a new value is written to the TCAn.PERBUF register. This bit is automatically cleared on an UPDATE condition.

### 21.5.8 Control Register F Set

**Name:** CTRLFSET  
**Offset:** 0x07  
**Reset:** 0x00  
**Property:** -

This register can be used instead of a Read-Modify-Write (RMW) to set individual bits by writing a '1' to its bit location.

	7	6	5	4	3	2	1	0
					CMP2BV	CMP1BV	CMP0BV	PERBV
Access					R/W	R/W	R/W	R/W
Reset					0	0	0	0

**Bit 3 – CMP2BV** Compare 2 Buffer Valid  
 See CMP0BV.

**Bit 2 – CMP1BV** Compare 1 Buffer Valid  
 See CMP0BV.

**Bit 1 – CMP0BV** Compare 0 Buffer Valid  
 The CMPnBV bits are set when a new value is written to the corresponding TCAn.CMPnBUF register. These bits are automatically cleared on an UPDATE condition.

**Bit 0 – PERBV** Period Buffer Valid  
 This bit is set when a new value is written to the TCAn.PERBUF register. This bit is automatically cleared on an UPDATE condition.

### 21.5.9 Event Control

**Name:** EVCTRL  
**Offset:** 0x09  
**Reset:** 0x00  
**Property:** -

Bit	7	6	5	4	3	2	1	0
	EVACTB[2:0]			CNTBEI	EVACTA[2:0]			CNTAEI
Access	R/W	R/W	R/W	R/W	R/W	R/W	R/W	R/W
Reset	0	0	0	0	0	0	0	0

#### Bits 7:5 – EVACTB[2:0] Event Action B

These bits define what action the counter will take upon certain event conditions.

Value	Name	Description
0x0	NONE	No action
0x1	-	Reserved
0x2	-	Reserved
0x3	UPDOWN	Count prescaled clock cycles or count events according to setting for event input A. The event signal controls the count direction, up when low and down when high.
0x4	RESTART_POSEDGE	Restart counter on positive event edge
0x5	RESTART_ANYEDGE	Restart counter on any event edge
0x6	RESTART_HIGHLVL	Restart counter while the event signal is high
Other	-	Reserved

#### Bit 4 – CNTBEI Enable Counter Event Input B

Value	Description
0	Counter Event input B is disabled
1	Counter Event input B is enabled according to EVACTB bit field

#### Bits 3:1 – EVACTA[2:0] Event Action A

These bits define what action the counter will take upon certain event conditions.

Value	Name	Description
0x0	CNT_POSEDGE	Count on positive event edge
0x1	CNT_ANYEDGE	Count on any event edge
0x2	CNT_HIGHLVL	Count prescaled clock cycles while the event signal is high
0x3	UPDOWN	Count prescaled clock cycles. The event signal controls the count direction, up when low and down when high.
Other		Reserved

#### Bit 0 – CNTAEI Enable Counter Event Input A

Value	Description
0	Counter Event input A is disabled
1	Counter Event input A is enabled according to EVACTA bit field

**21.5.10 Interrupt Control Register - Normal Mode**

**Name:** INTCTRL  
**Offset:** 0x0A  
**Reset:** 0x00  
**Property:** -

	7	6	5	4	3	2	1	0
		CMP2	CMP1	CMP0				OVF
Access		R/W	R/W	R/W				R/W
Reset		0	0	0				0

**Bit 6 – CMP2** Compare Channel 2 Interrupt Enable  
 See CMP0.

**Bit 5 – CMP1** Compare Channel 1 Interrupt Enable  
 See CMP0.

**Bit 4 – CMP0** Compare Channel 0 Interrupt Enable  
 Writing the CMPn bit to '1' enables the interrupt from Compare Channel n.

**Bit 0 – OVF** Timer Overflow/Underflow Interrupt Enable  
 Writing the OVF bit to '1' enables the overflow/underflow interrupt.

### 21.5.11 Interrupt Flag Register - Normal Mode

**Name:** INTFLAGS  
**Offset:** 0x0B  
**Reset:** 0x00  
**Property:** -

	7	6	5	4	3	2	1	0
Bit	CMP2		CMP1	CMP0				OVF
Access	R/W		R/W	R/W				R/W
Reset	0		0	0				0

**Bit 6 – CMP2** Compare Channel 2 Interrupt Flag  
 See the CMP0 flag description.

**Bit 5 – CMP1** Compare Channel 1 Interrupt Flag  
 See the CMP0 flag description.

**Bit 4 – CMP0** Compare Channel 0 Interrupt Flag  
 The Compare Interrupt (CMPn) flag is set on a compare match on the corresponding compare channel. For all modes of operation, the CMPn flag will be set when a compare match occurs between the Count (CNT) register and the corresponding Compare n (CMPn) register. The CMPn flag is not cleared automatically. It will be cleared only by writing a '1' to its bit location.

**Bit 0 – OVF** Overflow/Underflow Interrupt Flag  
 This flag is set either on a TOP (overflow) or BOTTOM (underflow) condition, depending on the WG MODE setting. The OVF flag is not cleared automatically. It will be cleared only by writing a '1' to its bit location.

**21.5.12 Debug Control Register**

**Name:** DBGCTRL  
**Offset:** 0x0E  
**Reset:** 0x00  
**Property:** -



**Bit 0 – DBGRUN** Run in Debug

Value	Description
0	The peripheral is halted in Break Debug mode and ignores events
1	The peripheral will continue to run in Break Debug mode when the CPU is halted

**21.5.13 Temporary Bits for 16-Bit Access**

**Name:** TEMP  
**Offset:** 0x0F  
**Reset:** 0x00  
**Property:** -

The Temporary register is used by the CPU for 16-bit single-cycle access to the 16-bit registers of this peripheral. The register is common for all the 16-bit registers of this peripheral and can be read and written by software. For more details on reading and writing 16-bit registers, refer to *Accessing 16-Bit Registers* in the *Memories* section.

Bit	7	6	5	4	3	2	1	0
	TEMP[7:0]							
Access	R/W	R/W	R/W	R/W	R/W	R/W	R/W	R/W
Reset	0	0	0	0	0	0	0	0

**Bits 7:0 – TEMP[7:0]** Temporary Bits for 16-bit Access

**21.5.14 Counter Register - Normal Mode**

**Name:** CNT  
**Offset:** 0x20  
**Reset:** 0x00  
**Property:** -

The TCA<sub>n</sub>.CNTL and TCA<sub>n</sub>.CNTH register pair represents the 16-bit value, TCA<sub>n</sub>.CNT. The low byte [7:0] (suffix L) is accessible at the original offset. The high byte [15:8] (suffix H) can be accessed at offset + 0x01.

CPU and UPDI write access has priority over internal updates of the register.

	Bit	15	14	13	12	11	10	9	8
		CNT[15:8]							
Access		R/W	R/W	R/W	R/W	R/W	R/W	R/W	R/W
Reset		0	0	0	0	0	0	0	0
	Bit	7	6	5	4	3	2	1	0
		CNT[7:0]							
Access		R/W	R/W	R/W	R/W	R/W	R/W	R/W	R/W
Reset		0	0	0	0	0	0	0	0

**Bits 15:8 – CNT[15:8]** Counter High Byte  
 These bits hold the MSB of the 16-bit Counter register.

**Bits 7:0 – CNT[7:0]** Counter Low Byte  
 These bits hold the LSB of the 16-bit Counter register.



**21.5.15 Period Register - Normal Mode**

**Name:** PER  
**Offset:** 0x26  
**Reset:** 0xFFFF  
**Property:** -

TCA<sub>n</sub>.PER contains the 16-bit TOP value in the timer/counter in all modes of operation, except Frequency Waveform Generation (FRQ).

The TCA<sub>n</sub>.PERL and TCA<sub>n</sub>.PERH register pair represents the 16-bit value, TCA<sub>n</sub>.PER. The low byte [7:0] (suffix L) is accessible at the original offset. The high byte [15:8] (suffix H) can be accessed at offset + 0x01.

	Bit	15	14	13	12	11	10	9	8
		PER[15:8]							
Access		R/W	R/W	R/W	R/W	R/W	R/W	R/W	R/W
Reset		1	1	1	1	1	1	1	1
	Bit	7	6	5	4	3	2	1	0
		PER[7:0]							
Access		R/W	R/W	R/W	R/W	R/W	R/W	R/W	R/W
Reset		1	1	1	1	1	1	1	1

**Bits 15:8 – PER[15:8]** Periodic High Byte  
 These bits hold the MSB of the 16-bit Period register.

**Bits 7:0 – PER[7:0]** Periodic Low Byte  
 These bits hold the LSB of the 16-bit Period register.

### 21.5.16 Compare n Register - Normal Mode

**Name:** CMPn  
**Offset:** 0x28 + n\*0x02 [n=0..2]  
**Reset:** 0x00  
**Property:** -

This register is continuously compared to the counter value. Normally, the outputs from the comparators are used to generate waveforms.

TCA<sub>n</sub>.CMP<sub>n</sub> registers are updated with the buffer value from their corresponding TCA<sub>n</sub>.CMP<sub>n</sub>BUF register when an UPDATE condition occurs.

The TCA<sub>n</sub>.CMP<sub>n</sub>L and TCA<sub>n</sub>.CMP<sub>n</sub>H register pair represents the 16-bit value, TCA<sub>n</sub>.CMP<sub>n</sub>. The low byte [7:0] (suffix L) is accessible at the original offset. The high byte [15:8] (suffix H) can be accessed at offset + 0x01.

Bit	15	14	13	12	11	10	9	8
	CMP[15:8]							
Access	R/W	R/W	R/W	R/W	R/W	R/W	R/W	R/W
Reset	0	0	0	0	0	0	0	0
Bit	7	6	5	4	3	2	1	0
	CMP[7:0]							
Access	R/W	R/W	R/W	R/W	R/W	R/W	R/W	R/W
Reset	0	0	0	0	0	0	0	0

**Bits 15:8 – CMP[15:8]** Compare High Byte  
 These bits hold the MSB of the 16-bit Compare register.

**Bits 7:0 – CMP[7:0]** Compare Low Byte  
 These bits hold the LSB of the 16-bit Compare register.

### 21.5.17 Period Buffer Register

**Name:** PERBUF  
**Offset:** 0x36  
**Reset:** 0xFFFF  
**Property:** -

This register serves as the buffer for the Period (TCAn.PER) register. Writing to this register from the CPU or UPDI will set the Period Buffer Valid (PERBV) bit in the TCAn.CTRLF register.

The TCAn.PERBUFH and TCAn.PERBUFL register pair represents the 16-bit value, TCAn.PERBUF. The low byte [7:0] (suffix L) is accessible at the original offset. The high byte [15:8] (suffix H) can be accessed at offset + 0x01.

Bit	15	14	13	12	11	10	9	8
	PERBUF[15:8]							
Access	R/W	R/W	R/W	R/W	R/W	R/W	R/W	R/W
Reset	1	1	1	1	1	1	1	1
Bit	7	6	5	4	3	2	1	0
	PERBUF[7:0]							
Access	R/W	R/W	R/W	R/W	R/W	R/W	R/W	R/W
Reset	1	1	1	1	1	1	1	1

**Bits 15:8 – PERBUF[15:8]** Period Buffer High Byte  
 These bits hold the MSB of the 16-bit Period Buffer register.

**Bits 7:0 – PERBUF[7:0]** Period Buffer Low Byte  
 These bits hold the LSB of the 16-bit Period Buffer register.

### 21.5.18 Compare n Buffer Register

**Name:** CMPnBUF  
**Offset:** 0x38 + n\*0x02 [n=0..2]  
**Reset:** 0x00  
**Property:** -

This register serves as the buffer for the associated Compare n (TCAn.CMPn) register. Writing to this register from the CPU or UPDI will set the Compare Buffer valid (CMPnBV) bit in the TCAn.CTRLF register.

The TCAn.CMPnBUFL and TCAn.CMPnBUFH register pair represents the 16-bit value, TCAn.CMPnBUF. The low byte [7:0] (suffix L) is accessible at the original offset. The high byte [15:8] (suffix H) can be accessed at offset + 0x01.

	Bit	15	14	13	12	11	10	9	8
		CMPBUF[15:8]							
Access		R/W	R/W	R/W	R/W	R/W	R/W	R/W	R/W
Reset		0	0	0	0	0	0	0	0
	Bit	7	6	5	4	3	2	1	0
		CMPBUF[7:0]							
Access		R/W	R/W	R/W	R/W	R/W	R/W	R/W	R/W
Reset		0	0	0	0	0	0	0	0

**Bits 15:8 – CMPBUF[15:8]** Compare High Byte  
 These bits hold the MSB of the 16-bit Compare Buffer register.

**Bits 7:0 – CMPBUF[7:0]** Compare Low Byte  
 These bits hold the LSB of the 16-bit Compare Buffer register.

## 21.6 Register Summary - Split Mode

Offset	Name	Bit Pos.	7	6	5	4	3	2	1	0	
0x00	<a href="#">CTRLA</a>	7:0	RUNSTDBY					CLKSEL[2:0]		ENABLE	
0x01	<a href="#">CTRLB</a>	7:0		HCMP2EN	HCMP1EN	HCMP0EN		LCMP2EN	LCMP1EN	LCMP0EN	
0x02	<a href="#">CTRLC</a>	7:0		HCMP2OV	HCMP1OV	HCMP0OV		LCMP2OV	LCMP1OV	LCMP0OV	
0x03	<a href="#">CTRLD</a>	7:0								SPLITM	
0x04	<a href="#">CTRLECLR</a>	7:0					CMD[1:0]		CMDEN[1:0]		
0x05	<a href="#">CTRLESET</a>	7:0					CMD[1:0]		CMDEN[1:0]		
0x06	Reserved										
...											
0x09											
0x0A	<a href="#">INTCTRL</a>	7:0		LCMP2	LCMP1	LCMP0			HUNF	LUNF	
0x0B	<a href="#">INTFLAGS</a>	7:0		LCMP2	LCMP1	LCMP0			HUNF	LUNF	
0x0C	Reserved										
...											
0x0D											
0x0E	<a href="#">DBGCTRL</a>	7:0								DBGRUN	
0x0F	Reserved										
...											
0x1F											
0x20	<a href="#">LCNT</a>	7:0	LCNT[7:0]								
0x21	<a href="#">HCNT</a>	7:0	HCNT[7:0]								
0x22	Reserved										
...											
0x25											
0x26		<a href="#">LPER</a>	7:0	LPER[7:0]							
0x27	<a href="#">HPER</a>	7:0	HPER[7:0]								
0x28	<a href="#">LCMP0</a>	7:0	LCMP[7:0]								
0x29	<a href="#">HCMP0</a>	7:0	HCMP[7:0]								
0x2A	<a href="#">LCMP1</a>	7:0	LCMP[7:0]								
0x2B	<a href="#">HCMP1</a>	7:0	HCMP[7:0]								
0x2C	<a href="#">LCMP2</a>	7:0	LCMP[7:0]								
0x2D	<a href="#">HCMP2</a>	7:0	HCMP[7:0]								

## 21.7 Register Description - Split Mode

### 21.7.1 Control A

**Name:** CTRLA  
**Offset:** 0x00  
**Reset:** 0x00  
**Property:** -

	Bit	7	6	5	4	3	2	1	0
		RUNSTDBY					CLKSEL[2:0]		ENABLE
Access		R/W				R/W	R/W	R/W	R/W
Reset		0				0	0	0	0

**Bit 7 – RUNSTDBY** Run Standby

Writing a '1' to this bit will enable the peripheral to run in Standby sleep mode.

**Bits 3:1 – CLKSEL[2:0]** Clock Select

These bits select the clock frequency for the timer/counter.

Value	Name	Description
0x0	DIV1	$f_{TCA} = f_{CLK\_PER}$
0x1	DIV2	$f_{TCA} = f_{CLK\_PER}/2$
0x2	DIV4	$f_{TCA} = f_{CLK\_PER}/4$
0x3	DIV8	$f_{TCA} = f_{CLK\_PER}/8$
0x4	DIV16	$f_{TCA} = f_{CLK\_PER}/16$
0x5	DIV64	$f_{TCA} = f_{CLK\_PER}/64$
0x6	DIV256	$f_{TCA} = f_{CLK\_PER}/256$
0x7	DIV1024	$f_{TCA} = f_{CLK\_PER}/1024$

**Bit 0 – ENABLE** Enable

Value	Description
0	The peripheral is disabled
1	The peripheral is enabled

**21.7.2 Control B - Split Mode**

**Name:** CTRLB  
**Offset:** 0x01  
**Reset:** 0x00  
**Property:** -

	7	6	5	4	3	2	1	0
		HCMP2EN	HCMP1EN	HCMP0EN		LCMP2EN	LCMP1EN	LCMP0EN
Access		R/W	R/W	R/W		R/W	R/W	R/W
Reset		0	0	0		0	0	0

**Bit 6 – HCMP2EN** High byte Compare 2 Enable  
 See HCMP0EN.

**Bit 5 – HCMP1EN** High byte Compare 1 Enable  
 See HCMP0EN.

**Bit 4 – HCMP0EN** High byte Compare 0 Enable  
 Setting the HCMPnEN bit in the FRQ or PWM Waveform Generation mode of operation will override the port output register for the corresponding WO[n+3] pin.

**Bit 2 – LCMP2EN** Low byte Compare 2 Enable  
 See LCMP0EN.

**Bit 1 – LCMP1EN** Low byte Compare 1 Enable  
 See LCMP0EN.

**Bit 0 – LCMP0EN** Low byte Compare 0 Enable  
 Setting the LCMPnEN bit in the FRQ or PWM Waveform Generation mode of operation will override the port output register for the corresponding WOn pin.

### 21.7.3 Control C - Split Mode

**Name:** CTRLC  
**Offset:** 0x02  
**Reset:** 0x00  
**Property:** -

	7	6	5	4	3	2	1	0
Bit		HCMP2OV	HCMP1OV	HCMP0OV		LCMP2OV	LCMP1OV	LCMP0OV
Access		R/W	R/W	R/W		R/W	R/W	R/W
Reset		0	0	0		0	0	0

**Bit 6 – HCMP2OV** High byte Compare 2 Output Value  
 See HCMP0OV.

**Bit 5 – HCMP1OV** High byte Compare 1 Output Value  
 See HCMP0OV.

**Bit 4 – HCMP0OV** High byte Compare 0 Output Value  
 The HCMPnOV bit allows direct access to the output compare value of the waveform generator when the timer/counter is not enabled. This is used to set or clear the WO[n+3] output value when the timer/counter is not running.

**Bit 2 – LCMP2OV** Low byte Compare 2 Output Value  
 See LCMP0OV.

**Bit 1 – LCMP1OV** Low byte Compare 1 Output Value  
 See LCMP0OV.

**Bit 0 – LCMP0OV** Low byte Compare 0 Output Value  
 The LCMPnOV bit allows direct access to the output compare value of the waveform generator when the timer/counter is not enabled. This is used to set or clear the WOn output value when the timer/counter is not running.



21.7.4 Control D

Name: CTRLD  
Offset: 0x03  
Reset: 0x00  
Property: -

Bit	7	6	5	4	3	2	1	0
Access								SPLITM
Reset								0

**Bit 0 – SPLITM** Enable Split Mode

This bit sets the timer/counter in Split mode operation. It will then work as two 8-bit timer/counters. The register map will change compared to normal 16-bit mode.

### 21.7.5 Control Register E Clear - Split Mode

**Name:** CTRLCLR  
**Offset:** 0x04  
**Reset:** 0x00  
**Property:** -

This register can be used instead of a Read-Modify-Write (RMW) to clear individual bits by writing a '1' to its bit location.

	7	6	5	4	3	2	1	0
					CMD[1:0]		CMDEN[1:0]	
Access					R/W	R/W	R/W	R/W
Reset					0	0	0	0

#### Bits 3:2 – CMD[1:0] Command

These bits are used for software control of restart and reset of the timer/counter. The command bits are always read as '0'.

Value	Name	Description
0x0	NONE	No command
0x1	-	Reserved
0x2	RESTART	Force restart
0x3	RESET	Force hard Reset (ignored if the timer/counter is enabled)

#### Bits 1:0 – CMDEN[1:0] Command Enable

These bits configure what timer/counters the command given by the CMD-bits will be applied to.

Value	Name	Description
0x0	NONE	None
0x1	-	Reserved
0x2	-	Reserved
0x3	BOTH	Command (CMD) will be applied to both low byte and high byte timer/counter

### 21.7.6 Control Register E Set - Split Mode

**Name:** CTRLRESET  
**Offset:** 0x05  
**Reset:** 0x00  
**Property:** -

This register can be used instead of a Read-Modify-Write (RMW) to set individual bits by writing a '1' to its bit location.

	7	6	5	4	3	2	1	0
					CMD[1:0]		CMDEN[1:0]	
Access					R/W	R/W	R/W	R/W
Reset					0	0	0	0

#### Bits 3:2 – CMD[1:0] Command

This bit field used for software control of restart and reset of the timer/counter. The command bits are always read as '0'. The CMD bit field must be used together with the Command Enable (CMDEN) bits. Using the RESET command requires that both low byte and high byte timer/counter are selected with CMDEN.

Value	Name	Description
0x0	NONE	No command
0x1	-	Reserved
0x2	RESTART	Force restart
0x3	RESET	Force hard Reset (ignored if the timer/counter is enabled)

#### Bits 1:0 – CMDEN[1:0] Command Enable

These bits configure what timer/counters the command given by the CMD-bits will be applied to.

Value	Name	Description
0x0	NONE	None
0x1	-	Reserved
0x2	-	Reserved
0x3	BOTH	Command (CMD) will be applied to both low byte and high byte timer/counter

**21.7.7 Interrupt Control Register - Split Mode**

**Name:** INTCTRL  
**Offset:** 0x0A  
**Reset:** 0x00  
**Property:** -

	7	6	5	4	3	2	1	0
Access		LCMP2	LCMP1	LCMP0			HUNF	LUNF
Reset		R/W	R/W	R/W			R/W	R/W
		0	0	0			0	0

**Bit 6 – LCMP2** Low byte Compare Channel 2 Interrupt Enable  
 See LCMP0.

**Bit 5 – LCMP1** Low byte Compare Channel 1 Interrupt Enable  
 See LCMP0.

**Bit 4 – LCMP0** Low byte Compare Channel 0 Interrupt Enable  
 Writing the LCMPn bit to '1' enables the low byte Compare Channel n interrupt.

**Bit 1 – HUNF** High byte Underflow Interrupt Enable  
 Writing the HUNF bit to '1' enables the high byte underflow interrupt.

**Bit 0 – LUNF** Low byte Underflow Interrupt Enable  
 Writing the LUNF bit to '1' enables the low byte underflow interrupt.

### 21.7.8 Interrupt Flag Register - Split Mode

**Name:** INTFLAGS  
**Offset:** 0x0B  
**Reset:** 0x00  
**Property:** -

	7	6	5	4	3	2	1	0
		LCMP2	LCMP1	LCMP0			HUNF	LUNF
Access		R/W	R/W	R/W			R/W	R/W
Reset		0	0	0			0	0

**Bit 6 – LCMP2** Low byte Compare Channel 2 Interrupt Flag  
 See LCMP0 flag description.

**Bit 5 – LCMP1** Low byte Compare Channel 1 Interrupt Flag  
 See LCMP0 flag description.

**Bit 4 – LCMP0** Low byte Compare Channel 0 Interrupt Flag  
 The Low byte Compare Interrupt (LCMPn) flag is set on a compare match on the corresponding compare channel in the low byte timer.  
 For all modes of operation, the LCMPn flag will be set when a compare match occurs between the Low Byte Timer Counter (TCA<sub>n</sub>.LCNT) register and the corresponding Compare n (TCA<sub>n</sub>.LCMPn) register. The LCMPn flag will not be cleared automatically and has to be cleared by software. This is done by writing a '1' to its bit location.

**Bit 1 – HUNF** High byte Underflow Interrupt Flag  
 This flag is set on a high byte timer BOTTOM (underflow) condition. HUNF is not automatically cleared and needs to be cleared by software. This is done by writing a '1' to its bit location.

**Bit 0 – LUNF** Low byte Underflow Interrupt Flag  
 This flag is set on a low byte timer BOTTOM (underflow) condition. LUNF is not automatically cleared and needs to be cleared by software. This is done by writing a '1' to its bit location.

**21.7.9 Debug Control Register**

**Name:** DBGCTRL  
**Offset:** 0x0E  
**Reset:** 0x00  
**Property:** -



**Bit 0 – DBGRUN** Run in Debug

Value	Description
0	The peripheral is halted in Break Debug mode and ignores events
1	The peripheral will continue to run in Break Debug mode when the CPU is halted

**21.7.10 Low Byte Timer Counter Register - Split Mode**

**Name:** LCNT  
**Offset:** 0x20  
**Reset:** 0x00  
**Property:** -

TCA<sub>n</sub>.LCNT contains the counter value for the low byte timer. CPU and UPDI write access has priority over count, clear or reload of the counter.

Bit	7	6	5	4	3	2	1	0
	LCNT[7:0]							
Access	R/W	R/W	R/W	R/W	R/W	R/W	R/W	R/W
Reset	0	0	0	0	0	0	0	0

**Bits 7:0 – LCNT[7:0]** Counter Value for Low Byte Timer  
 These bits define the counter value of the low byte timer.

**21.7.11 High Byte Timer Counter Register - Split Mode**

**Name:** HCNT  
**Offset:** 0x21  
**Reset:** 0x00  
**Property:** -

TCA<sub>n</sub>.HCNT contains the counter value for the high byte timer. CPU and UPDI write access has priority over count, clear or reload of the counter.

Bit	7	6	5	4	3	2	1	0
	HCNT[7:0]							
Access	R/W	R/W	R/W	R/W	R/W	R/W	R/W	R/W
Reset	0	0	0	0	0	0	0	0

**Bits 7:0 – HCNT[7:0]** Counter Value for High Byte Timer  
 These bits define the counter value in high byte timer.



**21.7.12 Low Byte Timer Period Register - Split Mode**

**Name:** LPER  
**Offset:** 0x26  
**Reset:** 0xFF  
**Property:** -

The TCAn.LPER register contains the TOP value for the low byte timer.

	7	6	5	4	3	2	1	0
	LPER[7:0]							
Access	R/W	R/W	R/W	R/W	R/W	R/W	R/W	R/W
Reset	1	1	1	1	1	1	1	1

**Bits 7:0 – LPER[7:0]** Period Value Low Byte Timer  
 These bits hold the TOP value for the low byte timer.

**21.7.13 High Byte Period Register - Split Mode**

**Name:** HPER  
**Offset:** 0x27  
**Reset:** 0xFF  
**Property:** -

The TCA<sub>n</sub>.HPER register contains the TOP value for the high byte timer.

Bit	7	6	5	4	3	2	1	0
	HPER[7:0]							
Access	R/W	R/W	R/W	R/W	R/W	R/W	R/W	R/W
Reset	1	1	1	1	1	1	1	1

**Bits 7:0 – HPER[7:0]** Period Value High Byte Timer  
 These bits hold the TOP value for the high byte timer.

**21.7.14 Compare Register n For Low Byte Timer - Split Mode**

**Name:** LCMPn  
**Offset:** 0x28 + n\*0x02 [n=0..2]  
**Reset:** 0x00  
**Property:** -

The TCAn.LCMPn register represents the compare value of Compare Channel n for the low byte timer. This register is continuously compared to the counter value of the low byte timer, TCAn.LCNT. Normally, the outputs from the comparators are then used to generate waveforms.

Bit	7	6	5	4	3	2	1	0
	LCMP[7:0]							
Access	R/W	R/W	R/W	R/W	R/W	R/W	R/W	R/W
Reset	0	0	0	0	0	0	0	0

**Bits 7:0 – LCMP[7:0]** Compare Value of Channel n  
 These bits hold the compare value of channel n that is compared to TCAn.LCNT.

**21.7.15 High Byte Compare Register n - Split Mode**

**Name:** HCMPn  
**Offset:** 0x29 + n\*0x02 [n=0..2]  
**Reset:** 0x00  
**Property:** -

The TCAn.HCMPn register represents the compare value of Compare Channel n for the high byte timer. This register is continuously compared to the counter value of the high byte timer, TCAn.HCNT. Normally, the outputs from the comparators are then used to generate waveforms.

Bit	7	6	5	4	3	2	1	0
	HCMP[7:0]							
Access	R/W	R/W	R/W	R/W	R/W	R/W	R/W	R/W
Reset	0	0	0	0	0	0	0	0

**Bits 7:0 – HCMP[7:0]** Compare Value of Channel n  
 These bits hold the compare value of channel n that is compared to TCAn.HCNT.

## **22. TCB - 16-bit Timer/Counter Type B**

### **22.1 Features**

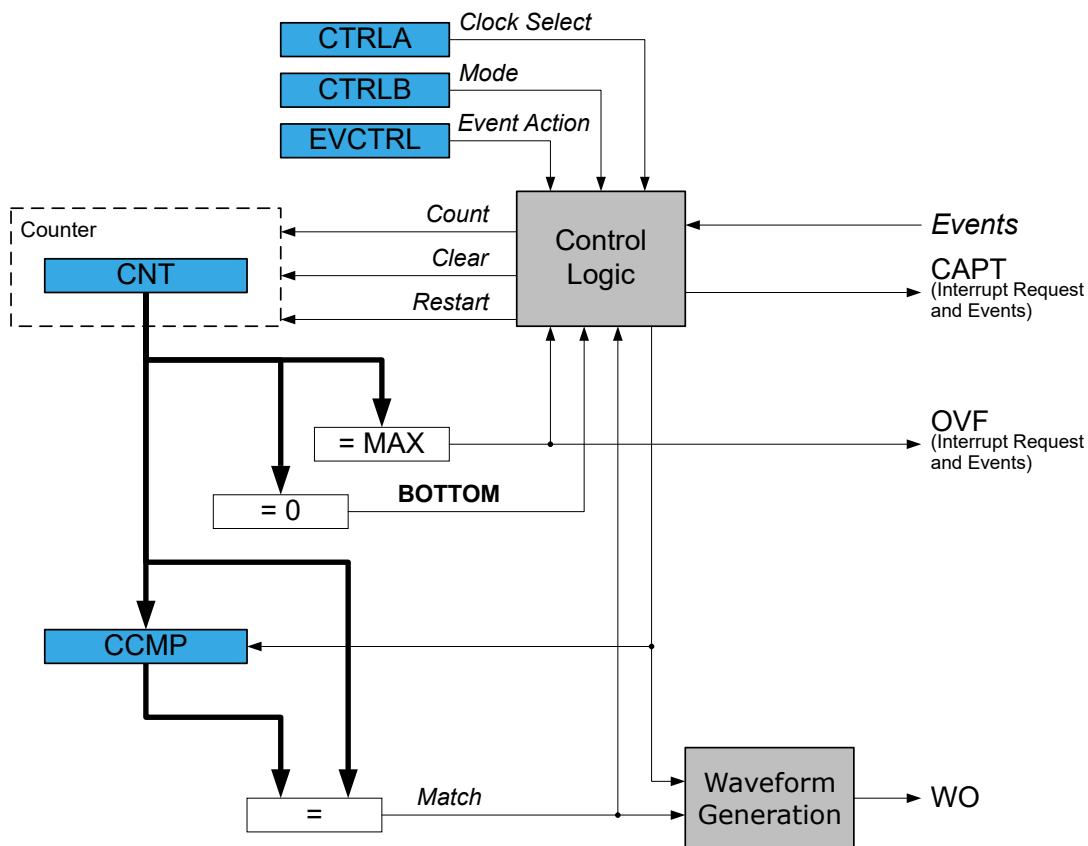
- 16-bit Counter Operation Modes:
  - Periodic interrupt
  - Time-out check
  - Input capture
    - On event
    - Frequency measurement
    - Pulse-width measurement
    - Frequency and pulse-width measurement
    - 32-bit capture
  - Single-shot
  - 8-bit Pulse-Width Modulation (PWM)
- Noise Canceler on Event Input
- Synchronize Operation with TCAn

### **22.2 Overview**

The capabilities of the 16-bit Timer/Counter type B (TCB) include frequency and waveform generation, and input capture on event with time and frequency measurement of digital signals. The TCB consists of a base counter and control logic that can be set in one of eight different modes, each mode providing unique functionality. The base counter is clocked by the peripheral clock with optional prescaling.

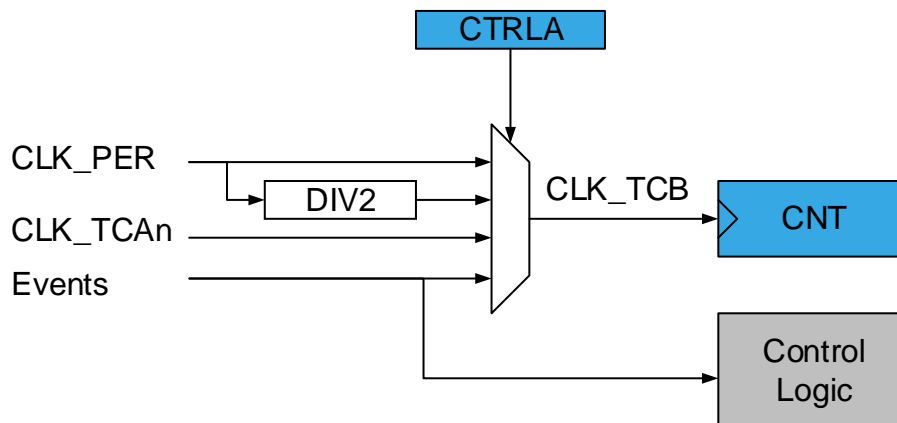
22.2.1 Block Diagram

Figure 22-1. Timer/Counter Type B Block Diagram



The timer/counter can be clocked from the Peripheral Clock (CLK\_PER), from a 16-bit Timer/Counter type A (CLK\_TCA<sub>n</sub>) or the Event System (EVSYS).

Figure 22-2. Timer/Counter Clock Logic



The Clock Select (CLKSEL) bit field in the Control A (TCBn.CTRLA) register selects one of the prescaler outputs directly, or an event channel as the clock (CLK\_TCB) input.

Setting the timer/counter to use the clock from a TCAn allows the timer/counter to run in sync with that TCAn.

By using the EVSYS, any event source, such as an external clock signal on any I/O pin, may be used as the counter clock input or as a control logic input. When an event action controlled operation is used, the clock selection must be set to use an event channel as the counter input.

### 22.2.2 Signal Description

Signal	Description	Type
WO	Digital Asynchronous Output	Waveform Output

## 22.3 Functional Description

### 22.3.1 Definitions

The following definitions are used throughout the documentation:

**Table 22-1. Timer/Counter Definitions**

Name	Description
BOTTOM	The counter reaches BOTTOM when it becomes 0x0000
MAX	The counter reaches the maximum when it becomes 0xFFFF
TOP	The counter reaches TOP when it becomes equal to the highest value in the count sequence
CNT	Count (TCBn.CNT) register value
CCMP	Capture/Compare (TCBn.CCMP) register value

**Note:** In general, the term ‘timer’ is used when the timer/counter is counting periodic clock ticks. The term ‘counter’ is used when the input signal has sporadic or irregular ticks.

### 22.3.2 Initialization

By default, the TCB is in Periodic Interrupt mode. Follow these steps to start using it:

1. Write a TOP value to the Compare/Capture (TCBn.CCMP) register.
2. Optional: Write the Compare/Capture Output Enable (CCMPEN) bit in the Control B (TCBn.CTRLB) register to ‘1’. This will make the waveform output available on the corresponding pin, overriding the value in the corresponding PORT output register. The corresponding pin direction must be configured as an output in the PORT peripheral.
3. Enable the counter by writing a ‘1’ to the ENABLE bit in the Control A (TCBn.CTRLA) register. The counter will start counting clock ticks according to the prescaler setting in the Clock Select (CLKSEL) bit field in the Control A (TCBn.CTRLA) register.
4. The counter value can be read from the Count (TCBn.CNT) register. The peripheral will generate a CAPT interrupt and event when the CNT value reaches TOP.
  - 4.1. If the Compare/Capture register is modified to a value lower than the current CNT, the peripheral will count to MAX and wrap around.
  - 4.2. At MAX, an OVF interrupt and event will be generated.

### 22.3.3 Operation

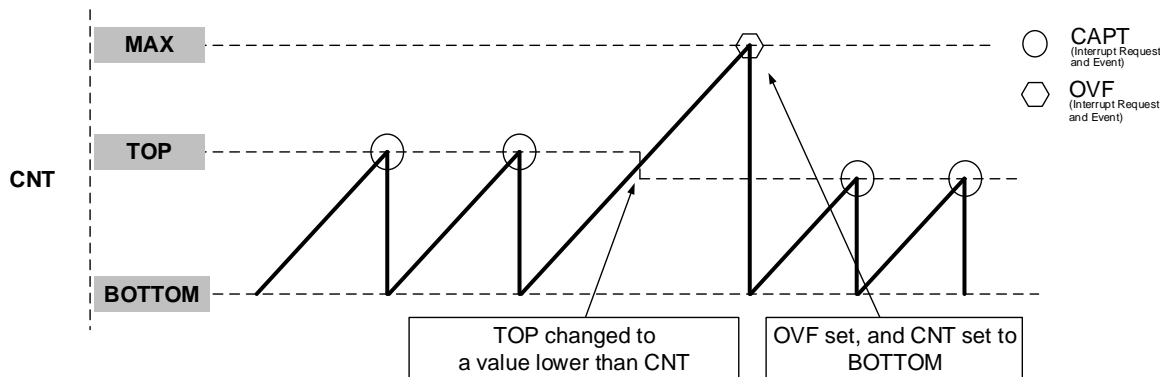
#### 22.3.3.1 Modes

The timer can be configured to run in one of the eight different modes described in the sections below. The event pulse needs to be longer than one peripheral clock cycle to ensure edge detection.

### 22.3.3.1.1 Periodic Interrupt Mode

In the Periodic Interrupt mode, the counter counts to the capture value and restarts from BOTTOM. A CAPT interrupt and event is generated when the CNT is equal to TOP. If TOP is updated to a value lower than CNT, upon reaching MAX, an OVF interrupt and event is generated, and the counter restarts from BOTTOM.

Figure 22-3. Periodic Interrupt Mode



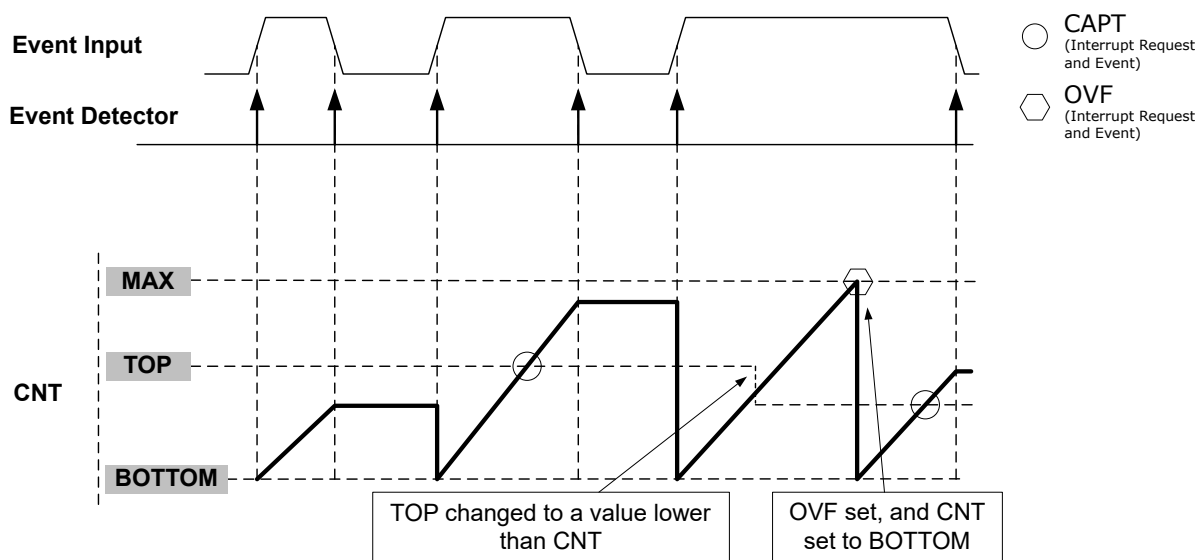
### 22.3.3.1.2 Time-Out Check Mode

In the Time-Out Check mode, the peripheral starts counting on the first signal edge and stops on the next signal edge detected on the event input channel. CNT remains stationary after the Stop edge (Freeze state). In Freeze state, the counter will restart on a new Start edge.

This mode requires TCB to be configured as an event user, and is explained in Events section.

Start or Stop edge is determined by the Event Edge (EDGE) bit in the Event Control (TCBn.EVCTRL) register. If CNT reaches TOP before the second edge, a CAPT interrupt and event will be generated. If TOP is updated to a value lower than the CNT upon reaching MAX, an OVF interrupt and the simultaneous event is generated, and the counter restarts from BOTTOM. In Freeze state, reading the Count (TCBn.CNT) register or Compare/Capture (TCBn.CCMP) register, or writing the Run (RUN) bit in the Status (TCBn.STATUS) register has no effect.

Figure 22-4. Time-Out Check Mode





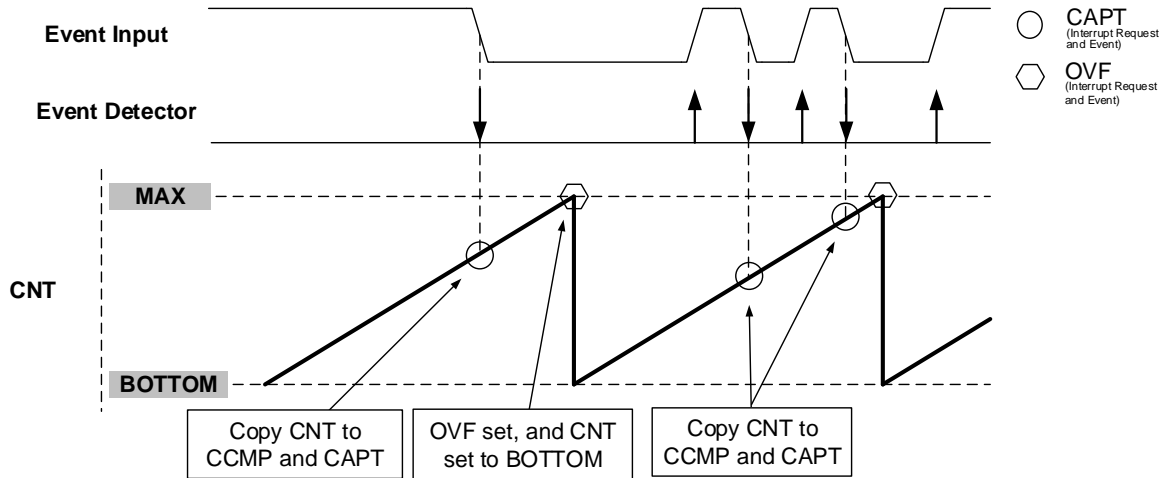
### 22.3.3.1.3 Input Capture on Event Mode

In the Input Capture on Event mode, the counter will count from BOTTOM to MAX continuously. When an event is detected, the CNT is transferred to the Capture/Compare (TCBn.CCMP) register, and a CAPT interrupt and event is generated. The Event edge detector can be configured to trigger a capture on either rising or falling edges.

This mode requires TCB to be configured as an event user, and is explained in Events section.

The figure below shows the input capture unit configured to capture on the falling edge of the event input signal. The CAPT Interrupt flag is automatically cleared after the low byte of the Compare/Capture (TCBn.CCMP) register has been read. An OVF interrupt and event is generated when the CNT is MAX.

Figure 22-5. Input Capture on Event



**Important:** It is recommended to write 0x0000 to the Count (TCBn.CNT) register when entering this mode from any other mode.

### 22.3.3.1.4 Input Capture Frequency Measurement Mode

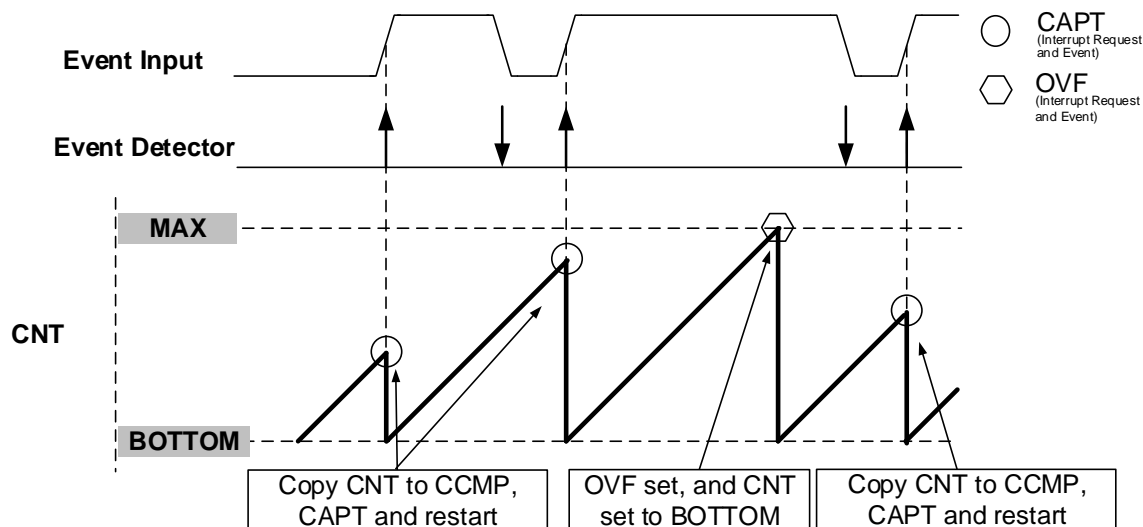
In the Input Capture Frequency Measurement mode, the TCB captures the counter value and restarts on either a positive or negative edge of the event input signal.

This mode requires TCB to be configured as an event user, and is explained in Events section.

The CAPT Interrupt flag is automatically cleared after the low byte of the Compare/Capture (TCBn.CCMP) register has been read. An OVF interrupt and event is generated when the CNT value is MAX.

The figure below illustrates this mode when configured to act on a rising edge.

Figure 22-6. Input Capture Frequency Measurement

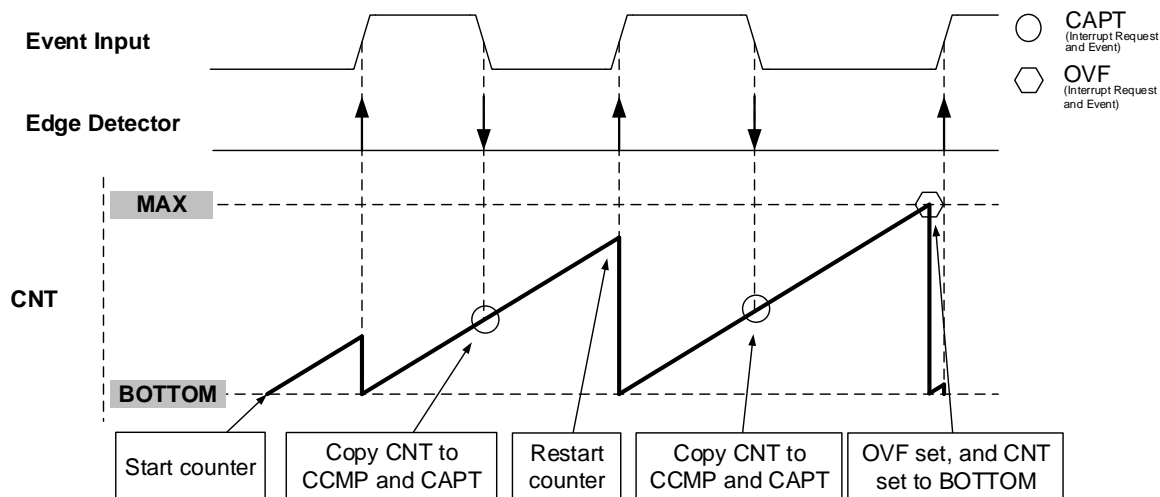


#### 22.3.3.1.5 Input Capture Pulse-Width Measurement Mode

In the Input Capture Pulse-Width Measurement mode, the input capture pulse-width measurement will restart the counter on a positive edge, and capture on the next falling edge before an interrupt request is generated. The CAPT Interrupt flag is automatically cleared after the low byte of the Compare/Capture (TCBn.CCMP) register has been read. An OVF interrupt and event is generated when the CNT is MAX. The timer will automatically switch between rising and falling edge detection, but a minimum edge separation of two clock cycles is required for correct behavior.

This mode requires TCB to be configured as an event user, and is explained in Events section.

Figure 22-7. Input Capture Pulse-Width Measurement



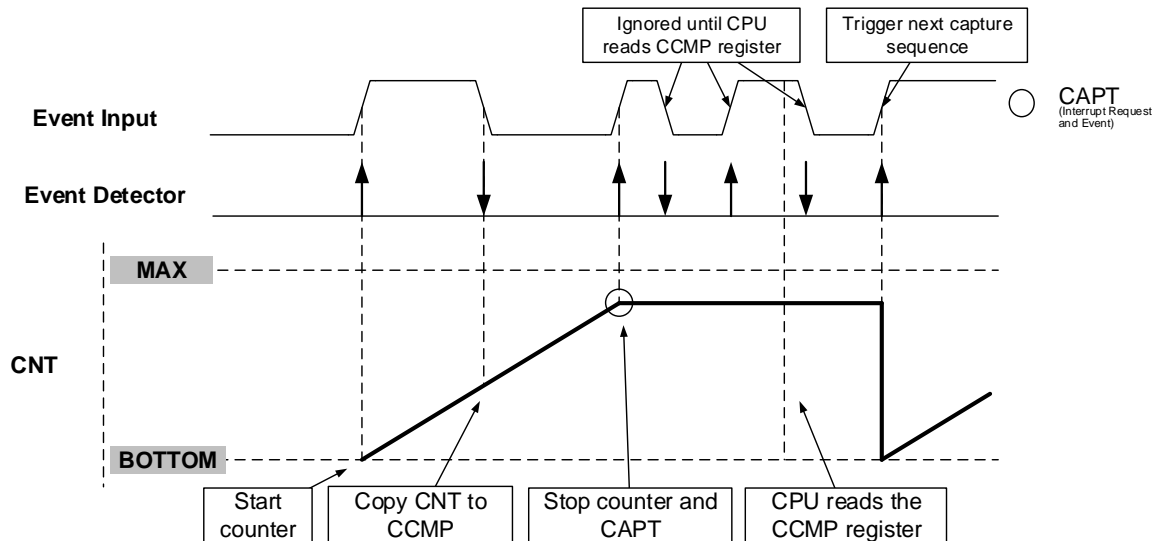
#### 22.3.3.1.6 Input Capture Frequency and Pulse-Width Measurement Mode

In the Input Capture Frequency and Pulse-Width Measurement mode, the timer will start counting when a positive edge is detected on the event input signal. The count value is captured on the following falling edge. The counter stops when the second rising edge of the event input signal is detected. This will set the CAPT interrupt flag.

This mode requires TCB to be configured as an event user, and is explained in Events section.

The CAPT Interrupt flag is automatically cleared after the low byte of the Compare/Capture (TCBn.CCMP) register has been read, and the timer/counter is ready for a new capture sequence. Therefore, the Count (TCBn.CNT) register must be read before the Compare/Capture (TCBn.CCMP) register, since it is reset to BOTTOM at the next positive edge of the event input signal. An OVF interrupt and event is generated when the CNT value is MAX.

**Figure 22-8. Input Capture Frequency and Pulse-Width Measurement**



### 22.3.3.1.7 Single-Shot Mode

The Single-Shot mode can be used to generate a pulse with a duration defined by the Compare (TCBn.CCMP) register, every time a rising or falling edge is observed on a connected event channel.

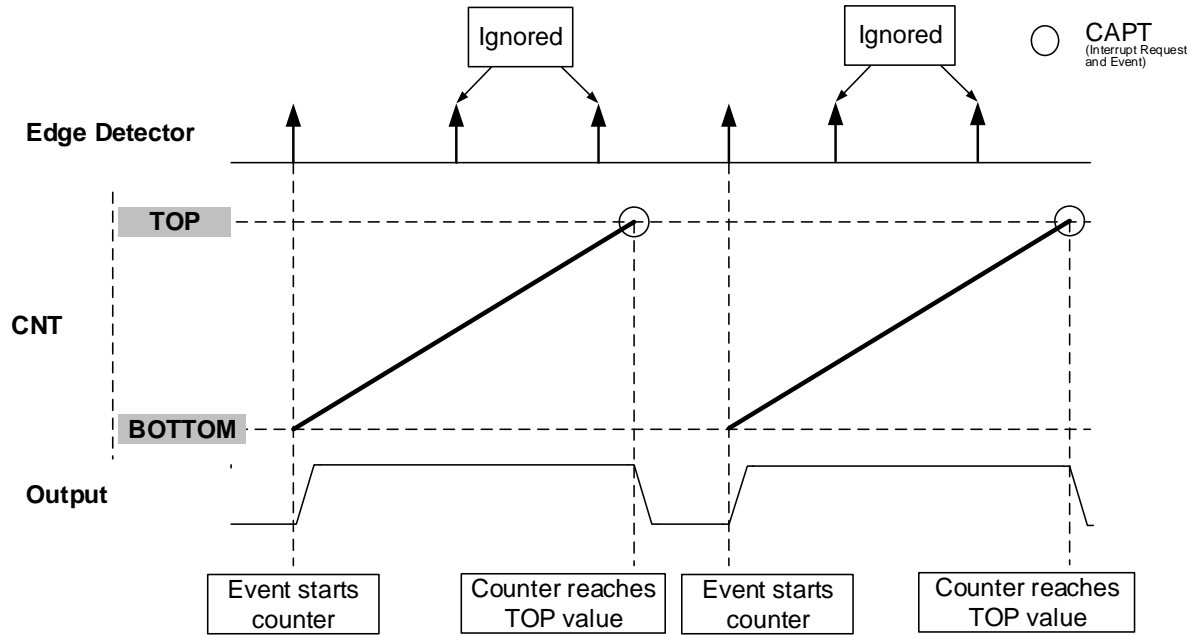
This mode requires TCB to be configured as an event user, and is explained in Events section.

When the counter is stopped, the output pin is set low. If an event is detected on the connected event channel, the timer will reset and start counting from BOTTOM to TOP while driving its output high. The RUN bit in the Status (TCBn.STATUS) register can be read to see if the counter is counting or not. When CNT reaches the CCMP register value, the counter will stop, and the output pin will go low for at least one counter clock cycle (TCB\_CLK), and a new event arriving during this time will be ignored. After this, there is a delay of two peripheral clock cycles (PER\_CLK) from when a new event is received until the output is set high.

The counter will start counting as soon as the peripheral is enabled, even without triggering by an event, or if the Event Edge (EDGE) bit in the Event Control (TCBn.EVCTRL) register is modified while the peripheral is enabled. This is prevented by writing TOP to the Counter register. Similar behavior is seen if the Event Edge (EDGE) bit in the Event Control (TCBn.EVCTRL) register is '1' while the module is enabled. Writing TOP to the Counter register prevents this as well.

If the Event Asynchronous (ASYNC) bit in the Control B (TCBn.CTRLB) register is written to '1', the timer will react asynchronously to an incoming event. An edge on the event will immediately cause the output signal to be set. The counter will still start counting two clock cycles after the event is received.

Figure 22-9. Single-Shot Mode

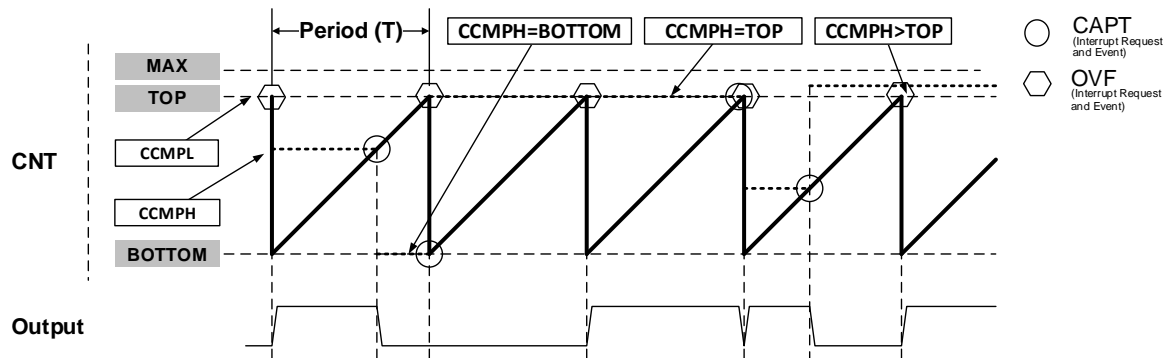


### 22.3.3.1.8 8-Bit PWM Mode

The TCB can be configured to run in 8-bit PWM mode, where each of the register pairs in the 16-bit Compare/Capture (TCBn.CCMPH and TCBn.CCMPL) register are used as individual Compare registers. The period (T) is controlled by CCMPL, while CCMPH controls the duty cycle of the waveform. The counter will continuously count from BOTTOM to CCMPL, and the output will be set at BOTTOM and cleared when the counter reaches CCMPH.

CCMPH is the number of cycles for which the output will be driven high. CCMPL+1 is the period of the output pulse.

Figure 22-10. 8-Bit PWM Mode



### 22.3.3.2 Output

Timer synchronization and output logic level are dependent on the selected Timer Mode (CNTMODE) bit field in Control B (TCBn.CTRLB) register. In Single-Shot mode, the timer/counter can be configured so that the signal generation happens asynchronously to an incoming event (ASYNC = 1 in TCBn.CTRLB). The output signal is then set immediately at the incoming event instead of being synchronized to the TCB clock. Even though the output is set immediately, it will take two to three CLK\_TCB cycles before the counter starts counting.

Writing the Compare/Capture Output Enable (CCMPEN) bit in TCBn.CTRLB to '1' enables the waveform output. This will make the waveform output available on the corresponding pin, overriding the value in the corresponding PORT output register. The corresponding pin direction must be configured as an output in the PORT peripheral.

The different configurations and their impact on the output are listed in the table below.

**Table 22-2. Output Configuration**

CCMPEN	CNTMODE	ASYNC	Output
1	Single-Shot mode	0	The output is high when the <u>counter starts</u> , and the output is low when the counter stops
		1	The output is high when the <u>event arrives</u> , and the output is low when the counter stops
	8-bit PWM mode	Not applicable	8-bit PWM mode
	Other modes	Not applicable	The Compare/Capture Pin Initial Value bit (CCMPINIT) in the Control B (TCBn.CTRLB) register selects the initial output level
0	Not applicable	Not applicable	No output

It is not recommended to change modes while the peripheral is enabled, as this can produce an unpredictable output. There is a possibility that an interrupt flag is set during the timer configuration. It is recommended to clear the Timer/Counter Interrupt Flags (TCBn.INTFLAGS) register after configuring the peripheral.

### 22.3.3.3 32-Bit Input Capture

Two 16-bit Timer/Counter Type B (TCBn) can be combined to work as a true 32-bit input capture:

One TCB is counting the two LSBs. Once this counter reaches MAX, an overflow (OVF) event is generated, and the counter wraps around. The second TCB is configured to count these OVF events and thus provides the two MSBs. The 32-bit counter value is concatenated from the two counter values.

To function as a 32-bit counter, the two TCBs and the system have to be set up as described in the following paragraphs.

#### System Configuration

- Configure a source (TCA, events, CLK\_PER) for the count input for the LSB TCB, according to the application requirements
- Configure the event system to route the OVF events from the LSB TCB (event generator) to the TCB intended for counting the MSB (event user)
- Configure the event system to route the same capture event (CAPT) generator to both TCBs

#### Configuration of the LSB Counter

- Select the configured count input by writing the Clock Select (CLKSEL) bit field in the Control A (CTRLA) register
- Write the Timer Mode (CNTMODE) bit field in the Control B (CTRLB) register to select the Input Capture on Event mode
- Ensure that the Cascade Two Timer/Counters (CASCADE) bit in CTRLA is '0'

#### Configuration of the MSB Counter

- Enable the 32-bit mode by writing the Cascade Two Timer/Counters bit (CASCADE) in CTRLA to '1'
- Select events as clock input by writing to the Clock Select (CLKSEL) bit field in the Control A (CTRLA) register
- Write the Timer Mode (CNTMODE) bit field in the Control B (CTRLB) register to select the Input Capture on Event mode

### Capturing a 32-Bit Counter Value

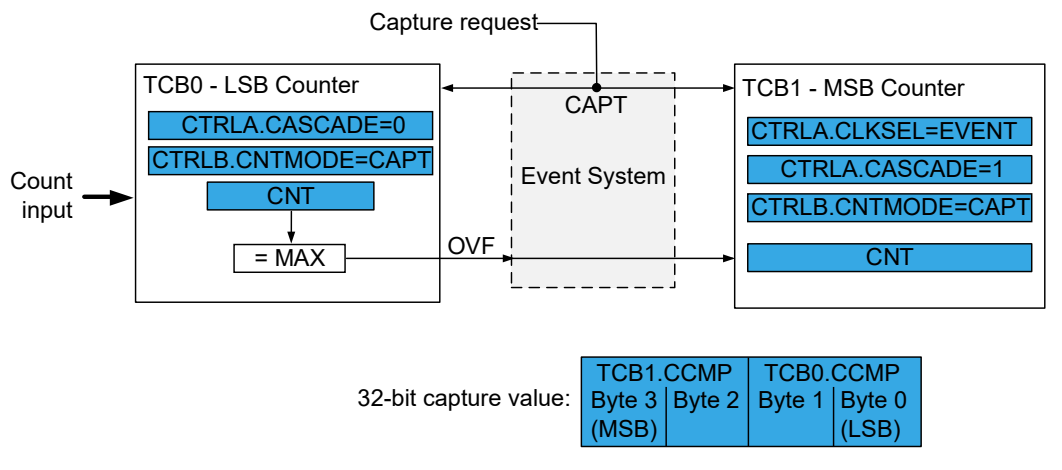
To acquire a 32-bit counter value, send a CAPT event to both TCBs. Both TCBs are running in Input Capture on Event mode, so each will capture the current counter value (CNT) in the respective Capture/Compare (CCMP) register. The 32-bit capture value is formed by concatenating the two CCMP registers.

#### Example 22-1. Using TCB0 as LSB Counter and TCB1 as MSB Counter

TCB0 is counting the count input, and TCB1 is counting the OVF signals from TCB0.

A CAPT event is generated and causes both TCB0 and TCB1 to copy their current CNT values to their respective CCMP registers. The two different CASCADE bit values allow correct timing of the CAPT event.

The captured 32-bit value is concatenated from TCB1.CCMP (MSB) and TCB0.CCMP (LSB).



#### 22.3.3.4 Noise Canceler

The Noise Canceler improves the noise immunity by using a simple digital filter scheme. When the Noise Filter (FILTER) bit in the Event Control (TCBn.EVCTRL) register is enabled, the peripheral monitors the event channel and keeps a record of the last four observed samples. If four consecutive samples are equal, the input is considered to be stable, and the signal is fed to the edge detector.

When enabled, the Noise Canceler introduces an additional delay of four peripheral clock cycles between a change applied to the input and the update of the Input Compare register.

The Noise Canceler uses the peripheral clock and is, therefore, not affected by the prescaler.

#### 22.3.3.5 Synchronized with Timer/Counter Type A

The TCB can be configured to use the clock (CLK\_TCA) of a Timer/Counter type A (TCAn) by writing to the Clock Select bit field (CLKSEL) in the Control A register (TCBn.CTRLA). In this setting, the TCB will count on the same clock source as selected in TCAn.

When the Synchronize Update (SYNCUPD) bit in the Control A (TCBn.CTRLA) register is written to '1', the TCB counter will restart when the TCAn counter restarts.

#### 22.3.4 Events

The TCB can generate the events described in the following table:

**Table 22-3. Event Generators in TCB**

Generator Name		Description	Event Type	Generating Clock Domain	Length of Event
Peripheral	Event				
TCBn	CAPT	CAPT flag set	Pulse	CLK_PER	One CLK_PER period
	OVF	OVF flag set			

The conditions for generating the CAPT and OVF events are identical to those that will raise the corresponding interrupt flags in the Timer/Counter Interrupt Flags (TCBn.INTFLAGS) register. Refer to the *Event System* section for more details regarding event users and Event System configuration.

The TCB can receive the events described in the following table:

**Table 22-4. Event Users and Available Event Actions in TCB**

User Name		Description	Input Detection	Async/Sync
Peripheral	Input			
TCBn	CAPT	Time-Out Check Count mode	Edge	Sync
		Input Capture on Event Count mode		
		Input Capture Frequency Measurement Count mode		
		Input Capture Pulse-Width Measurement Count mode		
		Input Capture Frequency and Pulse-Width Measurement Count mode		
		Single-Shot Count mode		
	COUNT	Event as clock source in combination with a count mode		Sync

CAPT and COUNT are TCB event users that detect and act upon input events.

The COUNT event user is enabled on the peripheral by modifying the Clock Select (CLKSEL) bit field in the Control A (TCBn.CTRLA) register to EVENT and setting up the Event System accordingly.

If the Capture Event Input Enable (CAPTEI) bit in the Event Control (TCBn.EVCTRL) register is written to '1', incoming events will result in an event action as defined by the Event Edge (EDGE) bit in Event Control (TCBn.EVCTRL) register and the Timer Mode (CNTMODE) bit field in Control B (TCBn.CTRLB) register. The event needs to last for at least one CLK\_PER cycle to be recognized.

If the Asynchronous mode is enabled for Single-Shot mode, the event is edge-triggered and will capture changes on the event input shorter than one peripheral clock cycle.

### 22.3.5 Interrupts

**Table 22-5. Available Interrupt Vectors and Sources**

Name	Vector Description	Conditions
CAPT	TCB interrupt	Depending on the operating mode. See the description of the CAPT bit in the TCBn.INTFLAG register.
OVF		The timer/counter overflows from MAX to BOTTOM.

When an interrupt condition occurs, the corresponding interrupt flag is set in the peripheral's Interrupt Flags (*peripheral*.INTFLAGS) register.

An interrupt source is enabled or disabled by writing to the corresponding enable bit in the peripheral's Interrupt Control (*peripheral*.INTCTRL) register.

An interrupt request is generated when the corresponding interrupt source is enabled, and the interrupt flag is set. The interrupt request remains active until the interrupt flag is cleared. See the peripheral's INTFLAGS register for details on how to clear interrupt flags.

### 22.3.6 Sleep Mode Operation

TCBn is, by default, disabled in Standby sleep mode. It will be halted as soon as the sleep mode is entered.

The module can stay fully operational in the Standby sleep mode if the Run Standby (RUNSTDBY) bit in the TCBn.CTRLA register is written to '1'.

All operations are halted in Power-Down sleep mode.



## 22.4 Register Summary

Offset	Name	Bit Pos.	7	6	5	4	3	2	1	0
0x00	<a href="#">CTRLA</a>	7:0		RUNSTDBY	CASCADE	SYNCUPD		CLKSEL[2:0]		ENABLE
0x01	<a href="#">CTRLB</a>	7:0		ASYNC	CCMPINIT	CCMPEN		CNTMODE[2:0]		
0x02	Reserved									
0x03										
0x04	<a href="#">EVCTRL</a>	7:0		FILTER		EDGE				CAPTEI
0x05	<a href="#">INTCTRL</a>	7:0							OVF	CAPT
0x06	<a href="#">INTFLAGS</a>	7:0							OVF	CAPT
0x07	<a href="#">STATUS</a>	7:0								RUN
0x08	<a href="#">DBGCTRL</a>	7:0								DBGRUN
0x09	<a href="#">TEMP</a>	7:0	TEMP[7:0]							
0x0A	<a href="#">CNT</a>	7:0	CNT[7:0]							
		15:8	CNT[15:8]							
0x0C	<a href="#">CCMP</a>	7:0	CCMP[7:0]							
		15:8	CCMP[15:8]							

## 22.5 Register Description

### 22.5.1 Control A

**Name:** CTRLA  
**Offset:** 0x00  
**Reset:** 0x00  
**Property:** -

	7	6	5	4	3	2	1	0
		RUNSTDBY	CASCADE	SYNCUPD		CLKSEL[2:0]		ENABLE
Access		R/W	R/W	R/W	R/W	R/W	R/W	R/W
Reset		0	0	0	0	0	0	0

**Bit 6 – RUNSTDBY** Run Standby  
 Writing a ‘1’ to this bit will enable the peripheral to run in Standby sleep mode.

**Bit 5 – CASCADE** Cascade Two Timer/Counters  
 Writing this bit to ‘1’ enables cascading of two 16-bit Timer/Counters type B (TCBn) for 32-bit operation using the Event System. This bit must be ‘1’ for the timer/counter used for the two Most Significant Bytes (MSB). When this bit is ‘1’, the selected event source for capture (CAPT) is delayed by one peripheral clock cycle. This compensates the carry propagation delay when cascading two counters via the Event System.

**Bit 4 – SYNCUPD** Synchronize Update  
 When this bit is written to ‘1’, the TCB will restart whenever TCA<sub>n</sub> is restarted or overflows. This can be used to synchronize capture with the PWM period. If TCA<sub>n</sub> is selected as the clock source, the TCB will restart when that TCA<sub>n</sub> is restarted. For other clock selections, it will restart together with TCA<sub>0</sub>.

**Bits 3:1 – CLKSEL[2:0]** Clock Select  
 Writing these bits selects the clock source for this peripheral.

Value	Name	Description
0x0	DIV1	CLK_PER
0x1	DIV2	CLK_PER / 2
0x2	TCA0	CLK_TCA from TCA0
0x3	TCA1	CLK_TCA from TCA1
0x4	-	Reserved
0x5	-	Reserved
0x6	-	Reserved
0x07	EVENT	Positive edge on event input

**Bit 0 – ENABLE** Enable  
 Writing this bit to ‘1’ enables the Timer/Counter type B peripheral.

## 22.5.2 Control B

**Name:** CTRLB  
**Offset:** 0x01  
**Reset:** 0x00  
**Property:** -

Bit	7	6	5	4	3	2	1	0
		ASYNC	CCMPINIT	CCMPEN		CNTMODE[2:0]		
Access		R/W	R/W	R/W		R/W	R/W	R/W
Reset		0	0	0		0	0	0

### Bit 6 – ASYNC Asynchronous Enable

Writing this bit to '1' will allow asynchronous updates of the TCB output signal in Single-Shot mode.

Value	Description
0	The output will go HIGH when the counter starts after synchronization
1	The output will go HIGH when an event arrives

### Bit 5 – CCMPINIT Compare/Capture Pin Initial Value

This bit is used to set the initial output value of the pin when a pin output is used. This bit has no effect in 8-bit PWM mode and Single-Shot mode.

Value	Description
0	Initial pin state is LOW
1	Initial pin state is HIGH

### Bit 4 – CCMPEN Compare/Capture Output Enable

Writing this bit to '1' enables the waveform output. This will make the waveform output available on the corresponding pin, overriding the value in the corresponding PORT output register. The corresponding pin direction must be configured as an output in the PORT peripheral.

Value	Description
0	Waveform output is not enabled on the corresponding pin.
1	Waveform output will override the output value of the corresponding pin.

### Bits 2:0 – CNTMODE[2:0] Timer Mode

Writing to this bit field selects the Timer mode.

Value	Name	Description
0x0	INT	Periodic Interrupt mode
0x1	TIMEOUT	Time-out Check mode
0x2	CAPT	Input Capture on Event mode
0x3	FRQ	Input Capture Frequency Measurement mode
0x4	PW	Input Capture Pulse-Width Measurement mode
0x5	FRQPW	Input Capture Frequency and Pulse-Width Measurement mode
0x6	SINGLE	Single-Shot mode
0x7	PWM8	8-Bit PWM mode

### 22.5.3 Event Control

**Name:** EVCTRL  
**Offset:** 0x04  
**Reset:** 0x00  
**Property:** -

	7	6	5	4	3	2	1	0
		FILTER		EDGE				CAPTEI
Access		R/W		R/W				R/W
Reset		0		0				0

**Bit 6 – FILTER** Input Capture Noise Cancellation Filter  
 Writing this bit to '1' enables the Input Capture Noise Cancellation unit.

**Bit 4 – EDGE** Event Edge  
 This bit is used to select the event edge. The effect of this bit is dependent on the selected Count Mode (CNTMODE) bit field in TCBn.CTRLB. “—” means that an event or edge has no effect in this mode.

Count Mode	EDGE	Positive Edge	Negative Edge
Periodic Interrupt mode	0	—	—
	1	—	—
Timeout Check mode	0	Start counter	Stop counter
	1	Stop counter	Start counter
Input Capture on Event mode	0	Input Capture, interrupt	—
	1	—	Input Capture, interrupt
Input Capture Frequency Measurement mode	0	Input Capture, clear and restart counter, interrupt	—
	1	—	Input Capture, clear and restart counter, interrupt
Input Capture Pulse-Width Measurement mode	0	Clear and restart counter	Input Capture, interrupt
	1	Input Capture, interrupt	Clear and restart counter
Input Capture Frequency and Pulse Width Measurement mode	0	<ul style="list-style-type: none"> <li>• On the 1<sup>st</sup> Positive: Clear and restart counter</li> <li>• On the following Negative: Input Capture</li> <li>• On the 2<sup>nd</sup> Positive: Stop counter, interrupt</li> </ul>	
	1	<ul style="list-style-type: none"> <li>• On the 1<sup>st</sup> Negative: Clear and restart counter</li> <li>• On the following Positive: Input Capture</li> <li>• On the 2<sup>nd</sup> Negative: Stop counter, interrupt</li> </ul>	
Single-Shot mode	0	Start counter	—
	1	—	Start counter
8-Bit PWM mode	0	—	—
	1	—	—

**Bit 0 – CAPTEI** Capture Event Input Enable  
 Writing this bit to '1' enables the input capture event.

22.5.4 Interrupt Control

Name: INTCTRL  
Offset: 0x05  
Reset: 0x00  
Property: -

Bit	7	6	5	4	3	2	1	0
Access							OVF	CAPT
Reset							R/W 0	R/W 0

**Bit 1 – OVF** Overflow Interrupt Enable  
Writing this bit to '1' enables interrupt on overflow.

**Bit 0 – CAPT** Capture Interrupt Enable  
Writing this bit to '1' enables interrupt on capture.

### 22.5.5 Interrupt Flags

**Name:** INTFLAGS  
**Offset:** 0x06  
**Reset:** 0x00  
**Property:** -

	7	6	5	4	3	2	1	0
Access							OVF	CAPT
Reset							R/W	R/W
							0	0

**Bit 1 – OVF** Overflow Interrupt Flag

This bit is set when an overflow interrupt occurs. The flag is set whenever the timer/counter wraps from MAX to BOTTOM.

The bit is cleared by writing a ‘1’ to the bit position.

**Bit 0 – CAPT** Capture Interrupt Flag

This bit is set when a capture interrupt occurs. The interrupt conditions are dependent on the Counter Mode (CNTMODE) bit field in the Control B (TCBn.CTRLB) register.

This bit is cleared by writing a ‘1’ to it or when the Capture register is read in Capture mode.

**Table 22-6. Interrupt Sources Set Conditions by Counter Mode**

Counter Mode	Interrupt Set Condition	TOP Value	CAPT
Periodic Interrupt mode	Set when the counter reaches TOP	CCMP	CNT == TOP
Timeout Check mode	Set when the counter reaches TOP		
Single-Shot mode	Set when the counter reaches TOP		
Input Capture Frequency Measurement mode	Set on edge when the Capture register is loaded and the counter restarts; the flag clears when the capture is read	--	On Event, copy CNT to CCMP, and restart counting (CNT == BOTTOM)
Input Capture on Event mode	Set when an event occurs and the Capture register is loaded; the flag clears when the capture is read		
Input Capture Pulse-Width Measurement mode	Set on edge when the Capture register is loaded; the previous edge initialized the count; the flag clears when the capture is read		
Input Capture Frequency and Pulse-Width Measurement mode	Set on the second edge (positive or negative) when the counter is stopped; the flag clears when the capture is read		
8-Bit PWM mode	Set when the counter reaches CCMH	CCML	CNT == CCMH

**22.5.6 Status**

**Name:** STATUS  
**Offset:** 0x07  
**Reset:** 0x00  
**Property:** -

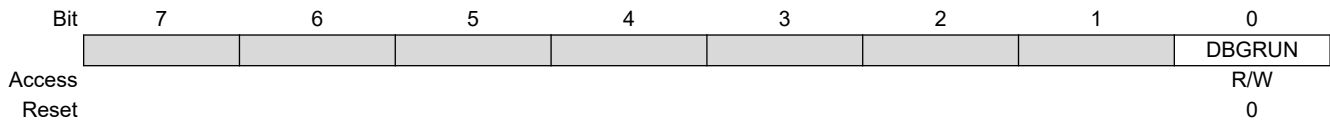
Bit	7	6	5	4	3	2	1	0
								RUN
Access								R
Reset								0

**Bit 0 – RUN** Run

When the counter is running, this bit is set to '1'. When the counter is stopped, this bit is cleared to '0'.  
The bit is read-only and cannot be set by UPDI.

**22.5.7 Debug Control**

**Name:** DBGCTRL  
**Offset:** 0x08  
**Reset:** 0x00  
**Property:** -



**Bit 0 – DBGRUN** Debug Run

Value	Description
0	The peripheral is halted in Break Debug mode and ignores events
1	The peripheral will continue to run in Break Debug mode when the CPU is halted



**22.5.8 Temporary Value**

**Name:** TEMP  
**Offset:** 0x09  
**Reset:** 0x00  
**Property:** -

The Temporary register is used by the CPU for 16-bit single-cycle access to the 16-bit registers of this peripheral. The register is common for all the 16-bit registers of this peripheral and can be read and written by software. For more details on reading and writing 16-bit registers, refer to *Accessing 16-Bit Registers* in the *Memories* section.

Bit	7	6	5	4	3	2	1	0
	TEMP[7:0]							
Access	R/W	R/W	R/W	R/W	R/W	R/W	R/W	R/W
Reset	0	0	0	0	0	0	0	0

**Bits 7:0 – TEMP[7:0]** Temporary Value

### 22.5.9 Count

**Name:** CNT  
**Offset:** 0x0A  
**Reset:** 0x00  
**Property:** -

The TCBn.CNTL and TCBn.CNTH register pair represents the 16-bit value TCBn.CNT. The low byte [7:0] (suffix L) is accessible at the original offset. The high byte [15:8] (suffix H) can be accessed at offset + 0x01.

CPU and UPDI write access has priority over internal updates of the register.

	Bit	15	14	13	12	11	10	9	8
		CNT[15:8]							
Access		R/W	R/W	R/W	R/W	R/W	R/W	R/W	R/W
Reset		0	0	0	0	0	0	0	0
	Bit	7	6	5	4	3	2	1	0
		CNT[7:0]							
Access		R/W	R/W	R/W	R/W	R/W	R/W	R/W	R/W
Reset		0	0	0	0	0	0	0	0

**Bits 15:8 – CNT[15:8]** Count Value High  
 These bits hold the MSB of the 16-bit Counter register.

**Bits 7:0 – CNT[7:0]** Count Value Low  
 These bits hold the LSB of the 16-bit Counter register.

### 22.5.10 Capture/Compare

**Name:** CCMP  
**Offset:** 0x0C  
**Reset:** 0x00  
**Property:** -

The TCBn.CCMPL and TCBn.CCMPH register pair represents the 16-bit value TCBn.CCMP. The low byte [7:0] (suffix L) is accessible at the original offset. The high byte [15:8] (suffix H) can be accessed at offset + 0x01.

This register has different functions depending on the mode of operation:

- For Capture operation, these registers contain the captured value of the counter at the time the capture occurs
- In Periodic Interrupt/Time-Out and Single-Shot mode, this register acts as the TOP value
- In 8-bit PWM mode, TCBn.CCMPL and TCBn.CCMPH act as two independent registers: The period of the waveform is controlled by CCMPH, while CCMPH controls the duty cycle.

Bit	15	14	13	12	11	10	9	8
	CCMP[15:8]							
Access	R/W	R/W	R/W	R/W	R/W	R/W	R/W	R/W
Reset	0	0	0	0	0	0	0	0
Bit	7	6	5	4	3	2	1	0
	CCMP[7:0]							
Access	R/W	R/W	R/W	R/W	R/W	R/W	R/W	R/W
Reset	0	0	0	0	0	0	0	0

**Bits 15:8 – CCMP[15:8]** Capture/Compare Value High Byte

These bits hold the MSB of the 16-bit compare, capture, and top value.

**Bits 7:0 – CCMP[7:0]** Capture/Compare Value Low Byte

These bits hold the LSB of the 16-bit compare, capture, and top value.

## **23. TCD - 12-Bit Timer/Counter Type D**

### **23.1 Features**

- 12-bit Timer/Counter
- Programmable Prescaler
- Double-Buffered Compare Registers
- Waveform Generation:
  - One Ramp mode
  - Two Ramp mode
  - Four Ramp mode
  - Dual Slope mode
- Two Separate Input Channels
- Software and Input Based Capture
- Programmable Filter for Input Events
- Conditional Waveform Generation on External Events:
  - Fault handling
  - Input blanking
  - Overload protection
  - Fast emergency stop by hardware
- Half-Bridge and Full-Bridge Output Support

### **23.2 Overview**

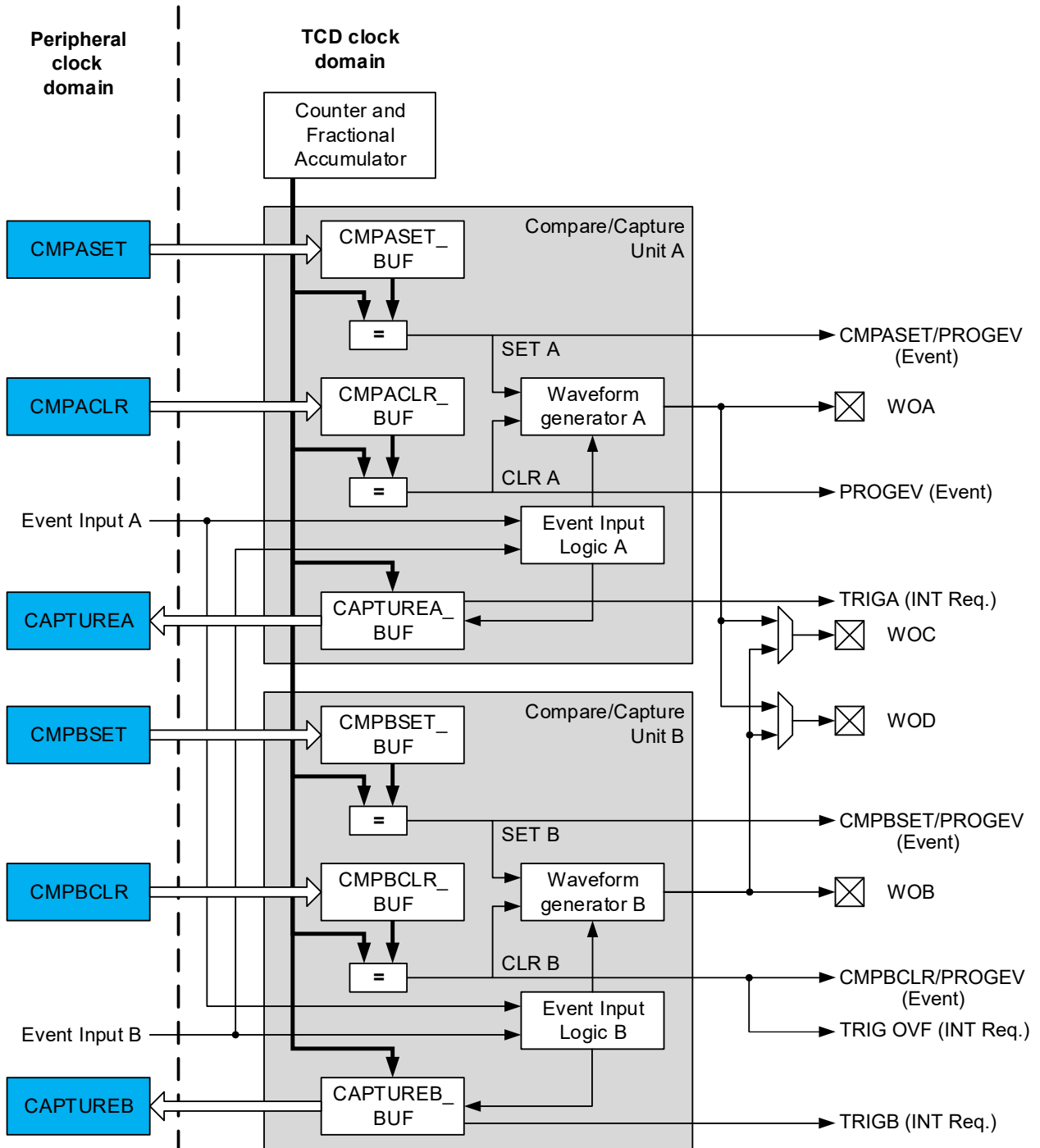
The Timer/Counter type D (TCD) is a high-performance waveform generator that consists of an asynchronous counter, a prescaler, and compare, capture and control logic.

The TCD contains a counter that can run on a clock which is asynchronous to the peripheral clock. It contains compare logic that generates two independent outputs with optional dead time. It is connected to the Event System for capture and deterministic Fault control. The timer/counter can generate interrupts and events on compare match and overflow.

This device provides one instance of the TCD peripheral, TCD0.

23.2.1 Block Diagram

Figure 23-1. Timer/Counter Block Diagram



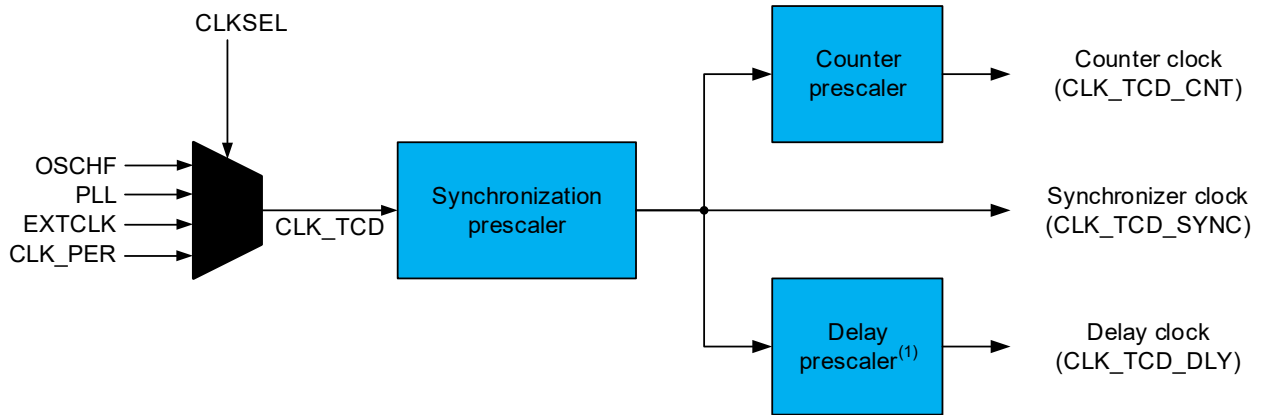
The TCD core is asynchronous to the peripheral clock. The timer/counter consists of two compare/capture units, each with a separate waveform output. There are also two extra waveform outputs which can be equal to the output from one of the units. For each compare/capture unit, there is a pair of compare registers which are stored in the respective peripheral registers (TCDn.CMPASET, TCDn.CMPACLR, TCDn.CMPBSET, TCDn.CMPBCLR).

During normal operation, the counter value is continuously compared to the compare registers. This is used to generate both interrupts and events.

The TCD can use the input events in ten different input modes, selected separately for the two input events. The input mode defines how the input events will affect the outputs, and where in the TCD cycle the counter must go when an event occurs.

The TCD can select between four different clock sources that can be prescaled. There are three different prescalers with separate controls, as shown below.

**Figure 23-2. Clock Selection and Prescalers Overview**



1. Used by input blanking/delay event out.

The TCD synchronizer clock is separate from the other module clocks, enabling faster synchronization between the TCD domain and the I/O domain.

The total prescaling for the counter is:

$$\text{SYNCPRESC\_division\_factor} \times \text{CNTPRESC\_division\_factor}$$

The delay prescaler is used to prescale the clock used for the input blanking/delayed event output functionality. The prescaler can be configured independently allowing separate range and accuracy settings from the counter functionality. The synchronization prescaler and counter prescaler can be configured from the Control A (TCDn.CTRLA) register, while the delay prescaler can be configured from the Delay Control (TCDn.DLYCTRL) register.

### 23.2.2 Signal Description

Signal	Description	Type
WOA	TCD waveform output A	Digital output
WOB	TCD waveform output B	Digital output
WOC	TCD waveform output C	Digital output
WOD	TCD waveform output D	Digital output

## 23.3 Functional Description

### 23.3.1 Definitions

The following definitions are used throughout the documentation:

**Table 23-1. Timer/Counter Definitions**

Name	Description
TCD cycle	The sequence of four states that the counter needs to go through before it has returned to the same position

.....continued

Name	Description
Input blanking	The functionality to ignore an event input for a programmable time in a selectable part of the TCD cycle
Asynchronous output control	Allows the event to override the output instantly when an event occurs. It is used for handling non-recoverable Faults
One ramp	The counter is reset to zero once during a TCD cycle
Two ramp	The counter is reset to zero two times during a TCD cycle
Four ramp	The counter is reset to zero four times during a TCD cycle
Dual ramp	The counter counts both up and down between zero and a selected top value during a TCD cycle
Input mode	A predefined setting that changes the output characteristics, based on the given input events

### 23.3.2 Initialization

To initialize the TCD:

1. Select the clock source and the prescaler from the Control A (TCDn.CTRLA) register.
2. Select the Waveform Generation Mode from the Control B (TCDn.CTRLB) register.
3. Optional: Configure the other static registers to the desired functionality.
4. Write the initial values in the Compare (TCDn.CMPxSET/CLR) registers.
5. Optional: Write the desired values to the other double-buffered registers.
6. Ensure that the Enable Ready (ENRDY) bit in the Status (TCDn.STATUS) register is set to '1'.
7. Enable the TCD by writing a '1' to the ENABLE bit in the Control A (TCDn.CTRLA) register.

### 23.3.3 Operation

#### 23.3.3.1 Register Synchronization Categories

Most of the I/O registers need to be synchronized to the TCD core clock domain. This is done differently for different register categories.

**Table 23-2. Categorization of Registers**

Enable and Command Registers	Double-Buffered Registers	Static Registers	Read-Only Registers	Normal I/O Registers
TCDn.CTRLA (ENABLE bit)	TCDn.DLYCTRL	TCDn.CTRLA <sup>(1)</sup> (All bits except ENABLE bit)	TCDn.STATUS	TCDn.INTCTRL
TCDn.CTRLE	TCDn.DLYVAL	TCDn.CTRLB	TCDn.CAPTUREA	TCDn.INTFLAGS
	TCDn.DITCTRL	TCDn.CTRLC	TCDn.CAPTUREB	
	TCDn.DITVAL	TCDn.CTRLD		
	TCDn.DBGCTRL	TCDn.EVCTRLA		
	TCDn.CMPASET	TCDn.EVCTRLB		
	TCDn.CMPACLAR	TCDn.INPUTCTRLA		
	TCDn.CMPBSET	TCDn.INPUTCTRLB		
	TCDn.CMPBCLR	TCDn.FAULTCTRL <sup>(2)</sup>		

**Notes:**

1. The bits in the Control A (TCDn.CTRLA) register are enable-protected, except the ENABLE bit. They can only be written when ENABLE is written to '0' first.
2. This register is protected by the Configuration Change Protection Mechanism, requiring a timed write procedure for changing its value settings.

**Enable and Command Registers**

Because of the synchronization between the clock domains, it is only possible to change the ENABLE bit in the Control A (TCDn.CTRLA) register, while the Enable Ready (ENRDY) bit in the Status (TCDn.STATUS) register is '1'.

The Control E (TCDn.CTRLE) register is automatically synchronized to the TCD core domain when the TCD is enabled and as long as no synchronization is ongoing already. Check if the Command Ready (CCMDRDY) bit in TCDn.STATUS is '1' to ensure that it is possible to issue a new command. TCDn.CTRLE is a strobe register that will clear itself when the command is sent.

**Double-Buffered Registers**

The double-buffered registers can be updated in normal I/O writes, while TCD is enabled and no synchronization between the two clock domains is ongoing. Check that the CMDRDY bit in TCDn.STATUS is '1' to ensure that it is possible to update the double-buffered registers. The values will be synchronized to the TCD core domain when a synchronization command is sent or when TCD is enabled.

**Table 23-3. Issuing Synchronization Command**

Synchronization Issuing Bit	Double Register Update
CTRLC.AUPDATE	Every time the CMPBCLR register is written, the synchronization occurs at the end of the TCD cycle
CTRLE.SYNC <sup>(1)</sup>	Occurs once, as soon as the SYNC bit is synchronized with the TDC domain
CTRLE.SYNCEOC <sup>(1)</sup>	Occurs once at the end of the next TCD cycle

**Note:**

1. If synchronization is already ongoing, the action has no effect.

**Static Registers**

Static registers cannot be updated while TCD is enabled. Therefore, these registers must be configured before enabling TCD. To see if TCD is enabled, check if ENABLE in TCDn.CTRLA is read as '1'.

**Normal I/O and Read-Only Registers**

Normal I/O and read-only registers are not constrained by any synchronization between the domains. The read-only registers inform about synchronization status and values synchronized from the core domain.

**23.3.3.2 Waveform Generation Modes**

The TCD provides four different Waveform Generation modes controlled by the Waveform Generation Mode (WGMODE) bit field in the Control B (TCDn.CTRLB) register. The Waveform Generation modes are:

- One Ramp mode
- Two Ramp mode
- Four Ramp mode
- Dual Slope mode

The Waveform Generation modes determine how the counter is counting during a TCD cycle and how the compare values influence the waveform. A TCD cycle is split into these states:

- Dead time WOA (DTA)
- On time WOA (OTA)
- Dead time WOB (DTB)



- On time WOB (OTB)

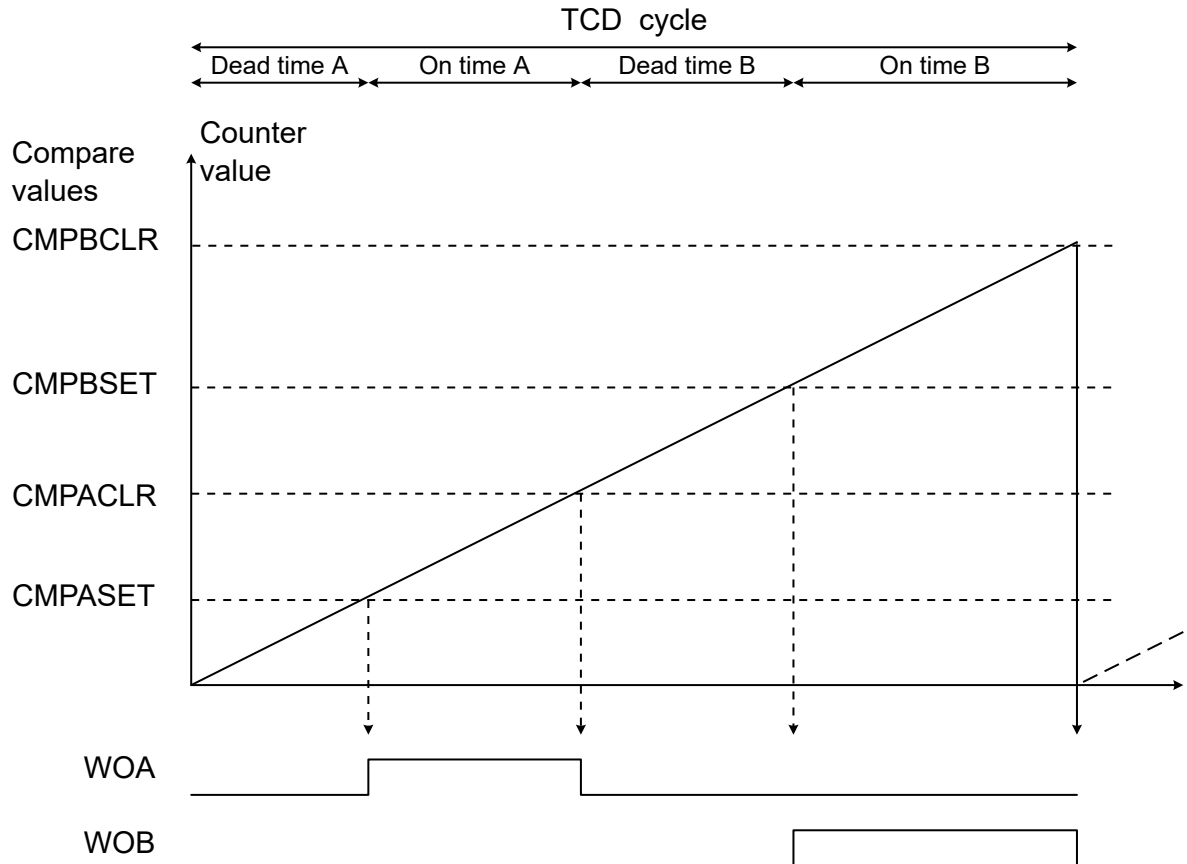
The Compare A Set (CMPASET), Compare A Clear (CMPACLR), Compare B Set (CMPBSET) and Compare B Clear (CMPBCLR) compare values define when each state ends and the next begins.

**23.3.3.2.1 One Ramp Mode**

In One Ramp mode, the TCD counter counts up until it reaches the CMPBCLR value. Then, the TCD cycle is completed, and the counter restarts from 0x000, beginning a new TCD cycle. The TCD cycle period is:

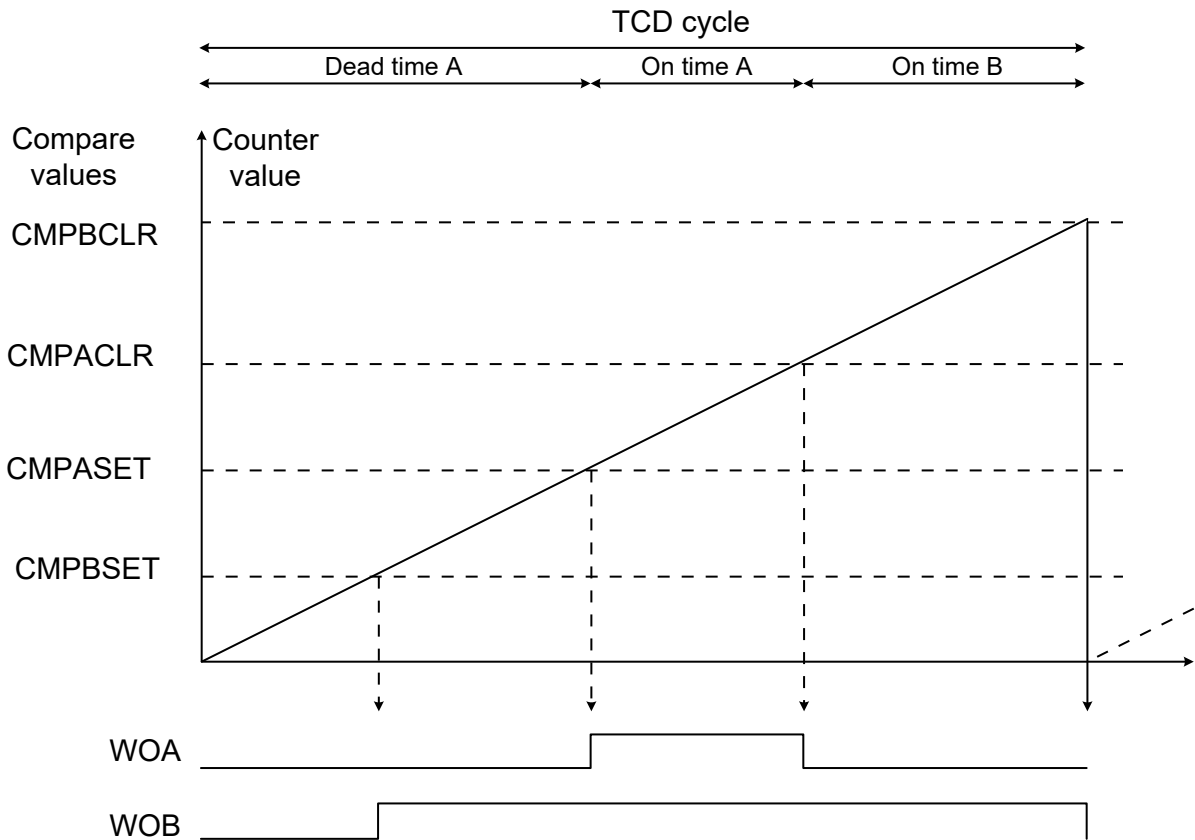
$$T_{TCD\_cycle} = \frac{(CMPBCLR + 1)}{f_{CLK\_TCD\_CNT}}$$

**Figure 23-3. One Ramp Mode**



In the figure above,  $CMPASET < CMPACLR < CMPBSET < CMPBCLR$ . In One Ramp mode, this is required to avoid overlapping outputs during the on time. The figure below is an example where  $CMPBSET < CMPASET < CMPACLR < CMPBCLR$ , which has overlapping outputs during the on time.

Figure 23-4. One Ramp Mode with  $CMPBSET < CMPASET$



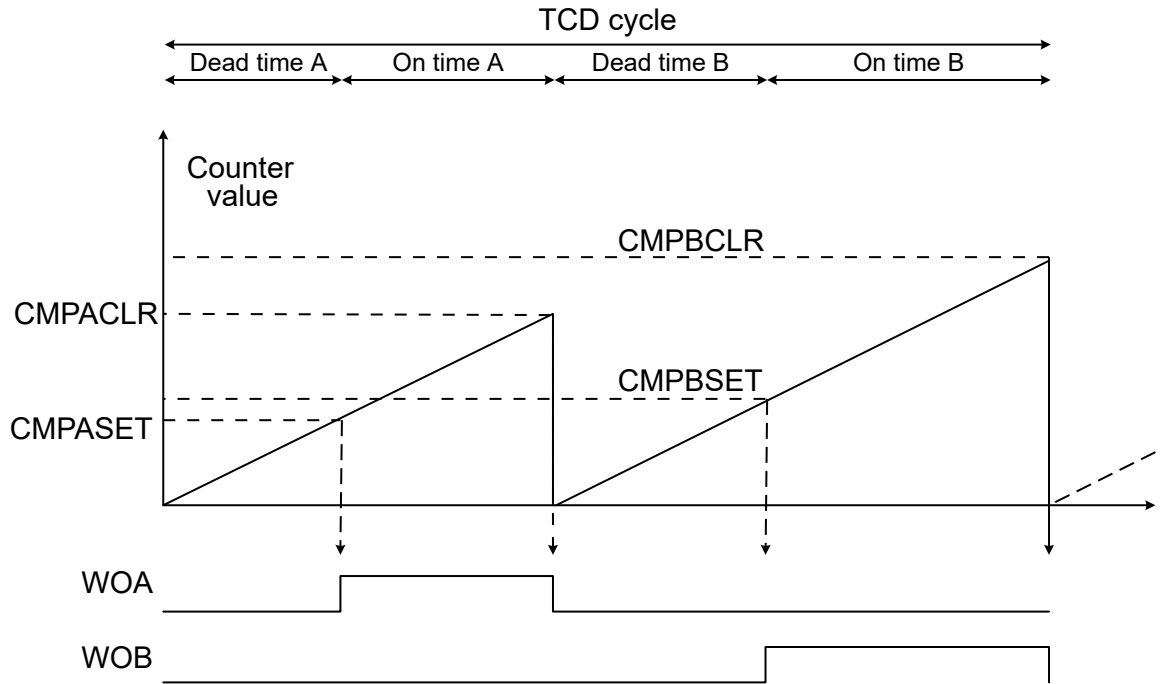
A match with  $CMPBCLR$  will always result in all outputs being cleared. If any of the other compare values are bigger than  $CMPBCLR$ , their associated effect will never occur. If the  $CMPACL R$  is smaller than the  $CMPASET$  value, the clear value will not have any effect.

### 23.3.3.2.2 Two Ramp Mode

In Two Ramp mode, the TCD counter counts up until it reaches the  $CMPACL R$  value, then it resets and counts up until it reaches the  $CMPBCLR$  value. Then, the TCD cycle is completed, and the counter restarts from  $0 \times 000$ , beginning a new TCD cycle. The TCD cycle period is given by:

$$T_{TCD\_cycle} = \frac{(CMPACL R + 1 + CMPBCLR + 1)}{f_{CLK\_TCD\_CNT}}$$

**Figure 23-5. Two Ramp Mode**



In the figure above,  $CMPASET < CMPACLR$  and  $CMPBSET < CMPBCLR$ . This causes the outputs to go high. There are no restrictions on the  $CMPASET$  and  $CMPACLR$  compared to the  $CMPBSET$  and  $CMPBCLR$  values.

In Two Ramp mode, it is not possible to get overlapping outputs without using the override feature. Even if  $CMPASET/CMPBSET > CMPACLR/CMPBCLR$ , the counter resets at  $CMPACLR/CMPBCLR$  and will never reach  $CMPASET/CMPBSET$ .

#### 23.3.3.2.3 Four Ramp Mode

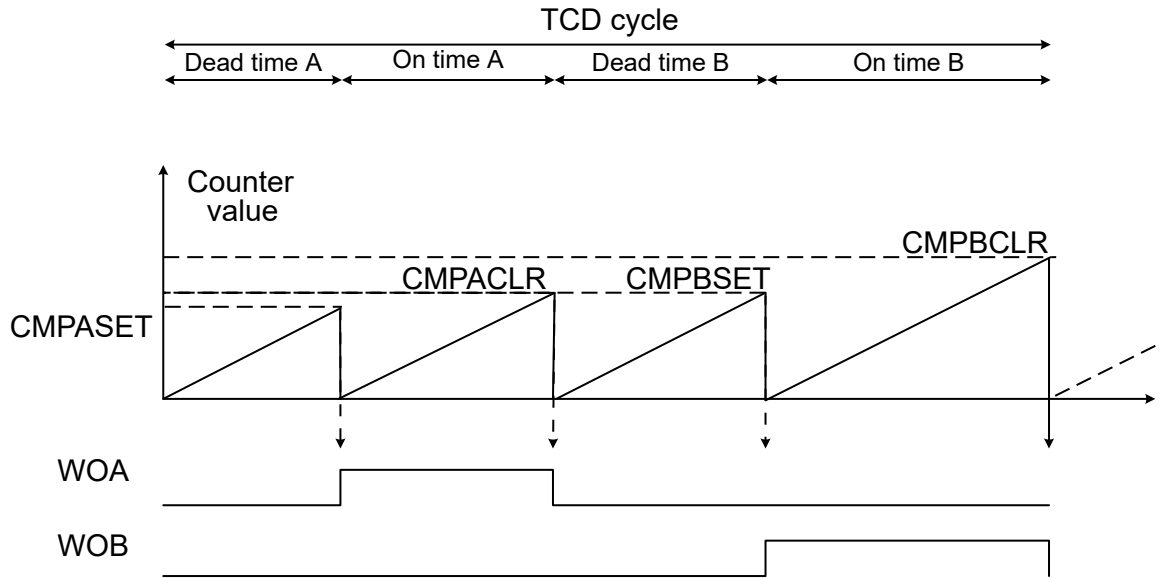
In Four Ramp mode, the TCD cycle follows this pattern:

1. A TCD cycle begins with the TCD counter counting up from zero until it reaches the  $CMPASET$  value, and resets to zero.
2. The counter counts up until it reaches the  $CMPACLR$  value, and resets to zero.
3. The counter counts up until it reaches the  $CMPBSET$  value, and resets to zero.
4. The counter counts up until it reaches the  $CMPBCLR$  value, and ends the TCD cycle by resetting to zero.

The TCD cycle period is given by:

$$T_{TCD\_cycle} = \frac{(CMPASET + 1) + (CMPACLR + 1) + (CMPBSET + 1) + (CMPBCLR + 1)}{f_{CLK\_TCD\_CNT}}$$

Figure 23-6. Four Ramp Mode



There are no restrictions regarding the compare values, because there are no dependencies between them.

In Four Ramp mode, it is not possible to get overlapping outputs without using the override feature.

#### 23.3.3.2.4 Dual Slope Mode

In Dual Slope mode, a TCD cycle consists of the TCD counter counting down from CMPBCLR value to zero, and up again to the CMPBCLR value. This gives a TCD cycle period:

$$T_{\text{TCD\_cycle}} = \frac{2 \times (\text{CMPBCLR} + 1)}{f_{\text{CLK\_TCD\_CNT}}}$$

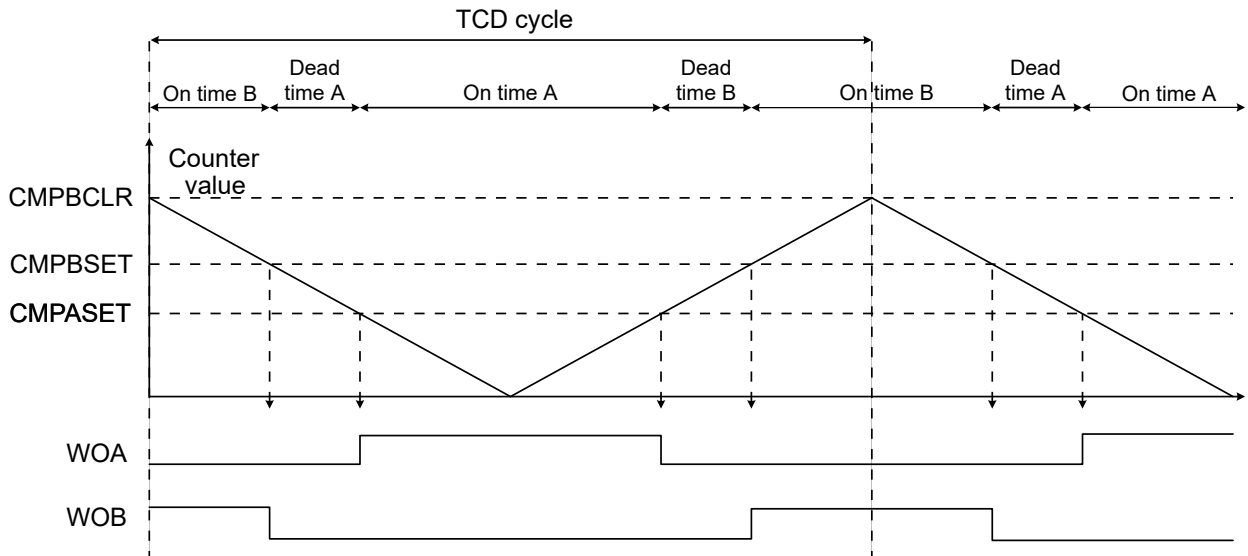
The WOA output is set when the TCD counter counts down and matches the CMPASET value. WOA is cleared when the TCD counter counts up and matches the CMPASET value.

The WOB output is set when the TCD counter counts up and matches the CMPBSET value. WOB is cleared when the TCD counter counts down and matches the CMPBSET value.

The outputs will overlap if  $\text{CMPASET} > \text{CMPBSET}$ .

CMPACL R is not used in Dual Slope mode. Writing a value to CMPACL R has no effect.

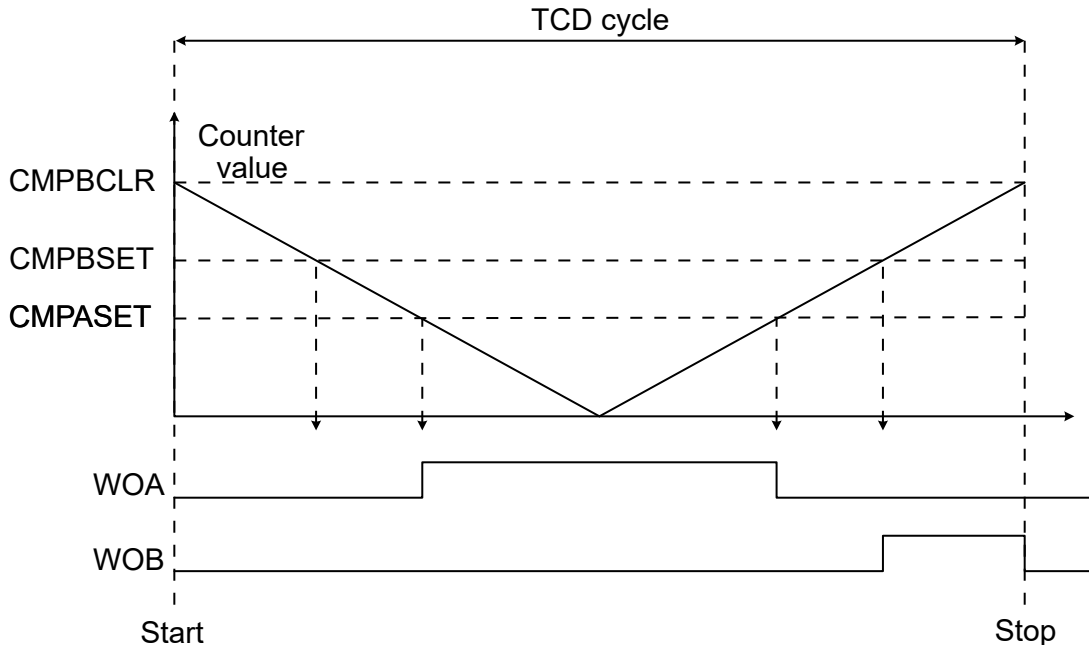
Figure 23-7. Dual Slope Mode



When starting the TCD in Dual Slope mode, the TCD counter starts at the CMPBCLR value and counts down. In the first cycle, the WOB will not be set until the TCD counter matches the CMPBSET value when counting up.

When the Disable at End of Cycle Strobe (DISEOC) bit in the Control E (TCDn.CTRLE) register is set, the TCD will automatically be disabled at the end of the TCD cycle.

**Figure 23-8. Dual Slope Mode Starting and Stopping**



### 23.3.3.3 Disabling TCD

Disabling the TCD can be done in two different ways:

1. By writing a '0' to the ENABLE bit in the Control A (TCDn.CTRLA) register. This disables the TCD instantly when synchronized to the TCD core domain.
2. By writing a '1' to the Disable at End of Cycle Strobe (DISEOC) bit in the Control E (TCDn.CTRLE) register. This disables the TCD at the end of the TCD cycle.

### 23.3.3.4 TCD Inputs

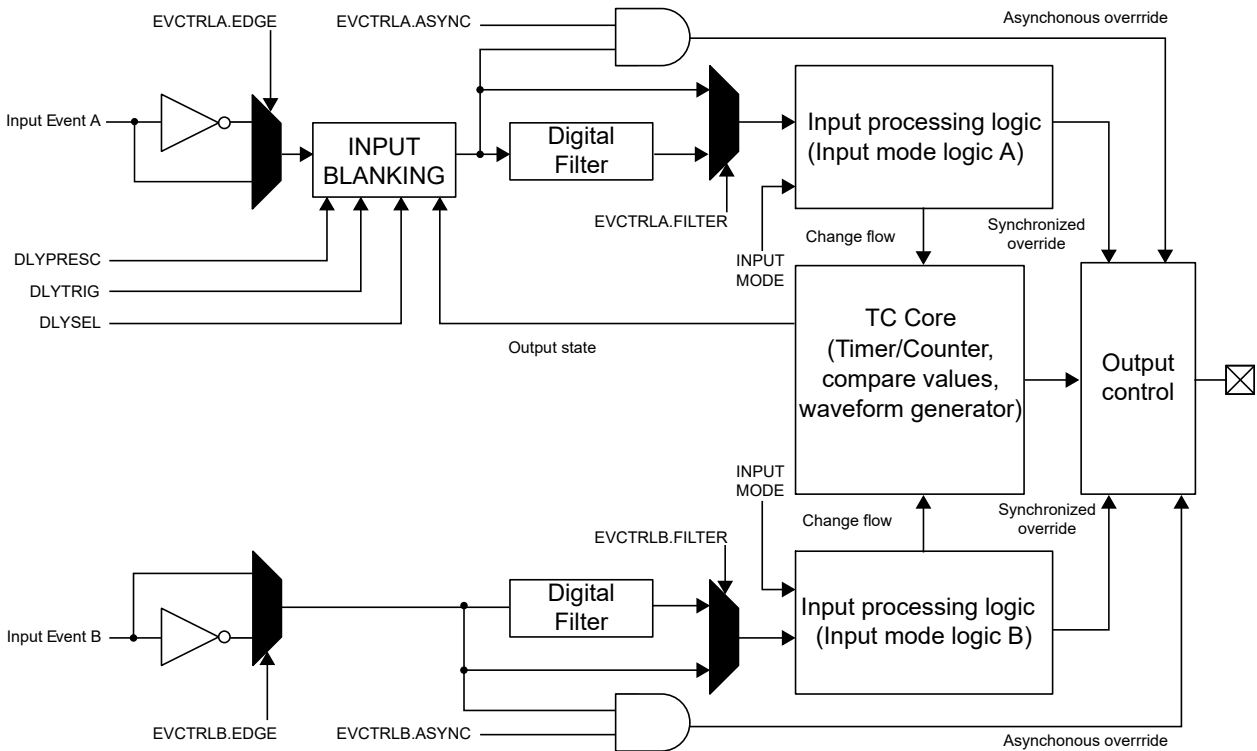
The TCD has two inputs connected to the Event System: input A and input B. Each input has a functionality connected to the corresponding output (WOA and WOB). This functionality is controlled by the Event Control (TCDn.EVCTRLA and TCDn.EVCTRLB) registers and the Input Control (TCDn.INPUTCTRLA and TCDn.INPUTCTRLB) registers.

To enable the input events, write a '1' to the Trigger Event Input Enable (TRIGEI) bit in the corresponding Event Control (TCDn.EVCTRLA or TCDn.EVCTRLB) register. The inputs will be used as a Fault detect by default, but they can also be used as a capture trigger. To enable a capture trigger, write a '1' to the ACTION bit in the corresponding Event Control (TCDn.EVCTRLA or TCDn.EVCTRLB) register. To disable Fault detect, the INPUTMODE bit field in the corresponding Input Control (TCDn.INPUTCTRLA or TCDn.INPUTCTRLB) register must be written to '0'.

There are ten different input modes for the Fault detection. The two inputs have the same functionality, except for input blanking which is only supported by input A. Input blanking is configured by the Delay Control (TCDn.DLYCTRL) register and the Delay Value (TCDn.DLYVAL) register.

The inputs are connected to the Event System. The connections between the event source and the TCD input must be configured in the Event System.

Figure 23-9. TCD Input Overview



There is a delay of two/three clock cycles on the TCD synchronizer clock between receiving the input event, processing it, and overriding the outputs. If using the asynchronous event detection, the outputs will override instantly outside the input processing.

#### 23.3.3.4.1 Input Blanking

Input blanking functionality masks out the input events for a programmable time in a selectable part of the TCD cycle. Input blanking can be used to mask out 'false' input events triggered right after changes on the outputs occur.

Input blanking can be enabled by configuring the Delay Select (DLYSEL) bit field in the Delay Control (TCDn.DLYCTRL) register. The trigger source is selected by the Delay Trigger (DLYTRIG) bit field in TCDn.DLYCTRL.

Input blanking uses the delay clock. After a trigger, a counter counts up until the Delay Value (DLYVAL) bit field in the Delay Value (TCDn.DLYVAL) register is reached. Afterward, input blanking is turned off. The TCD delay clock is a prescaled version of the synchronizer clock (CLK\_TCD\_SYNC). The division factor is set by the Delay Prescaler (DLYPRESC) bit field in the Delay Control (TCDn.DLYCTRL) register. The duration of the input blanking is given by:

$$t_{\text{BLANK}} = \frac{\text{DLYPRESC\_division\_factor} \times \text{DLYVAL}}{f_{\text{CLK\_TCD\_SYNC}}}$$

Input blanking uses the same logic as the programmable output event. For this reason, it is not possible to use both at the same time.

#### 23.3.3.4.2 Digital Filter

The digital filter for event input *x* is enabled by writing a '1' to the FILTER bit in the corresponding Event Control (TCDn.EVCTRLA or TCDn.EVCTRLB) register. When the digital filter is enabled, any pulse lasting less than four counter clock cycles will be filtered out. Any change on the incoming event will, therefore, take four counter clock cycles before it affects the input processing logic.

#### 23.3.3.4.3 Asynchronous Event Detection

To enable asynchronous event detection on an input event, the Event Configuration (CFG) bit field in the corresponding Event Control (TCDn.EVCTRLA or TCDn.EVCTRLB) register must be configured accordingly.

The asynchronous event detection makes it possible to asynchronously override the output when the input event occurs. What the input event will do depends on the input mode. The outputs have direct override while the counter flow will be changed when the event is synchronized to the synchronizer clock (CLK\_TCD\_SYNC).

It is not possible to use asynchronous event detection and digital filter at the same time.

#### 23.3.3.4.4 Software Commands

The following table displays the commands for the TCD module.

**Table 23-4. Software Commands**

Trigger	Software Command
The SYNCEOC bit in the TCDn.CTRLA register	Update the double-buffered registers at the end of the TCD cycle
The SYNC bit in the TCDn.CTRLA register	Update the double-buffered registers
The RESTART bit in the TCDn.CTRLA register	Restart the TCD counter
The SCAPTUREA bit in the TCDn.CTRLA register	Capture to Capture A (TCDn.CAPTUREA/H) register
The SCAPTUREB bit in the TCDn.CTRLA register	Capture to Capture B (TCDn.CAPTUREB/H) register

#### 23.3.3.4.5 Input Modes

The user can select between ten input modes. The selection is done by writing to the Input Mode (INPUTMODE) bit field in the Input Control (TCDn.INPUTCTRLA and TCDn.INPUTCTRLB) registers.

##### **Input Modes Validity**

Not all input modes work in all Waveform Generation modes. The table below shows the Waveform Generation modes in which the different input modes are valid.

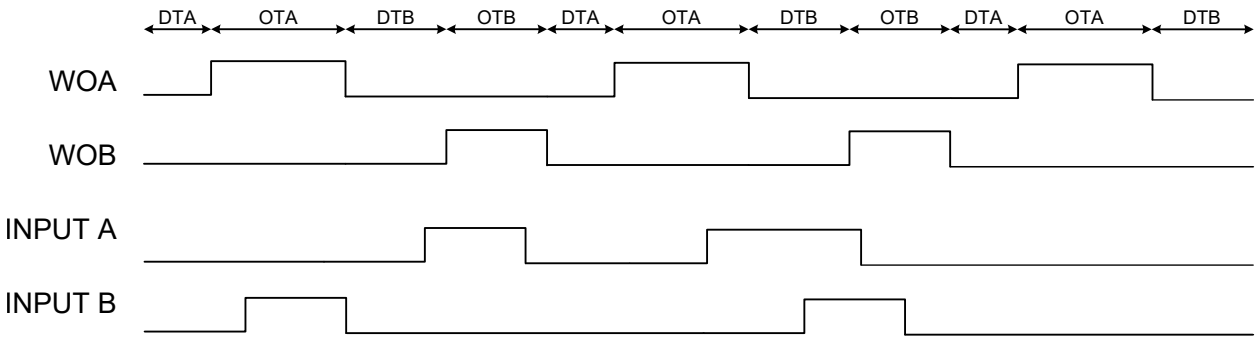
**Table 23-5. Input Modes Validity**

INPUTMODE	One Ramp Mode	Two Ramp Mode	Four Ramp Mode	Dual Slope Mode
0	Valid	Valid	Valid	Valid
1	Valid	Valid	Valid	Do not use
2	Do not use	Valid	Valid	Do not use
3	Do not use	Valid	Valid	Do not use
4	Valid	Valid	Valid	Valid
5	Do not use	Valid	Valid	Do not use
6	Do not use	Valid	Valid	Do not use
7	Valid	Valid	Valid	Valid
8	Valid	Valid	Valid	Do not use
9	Valid	Valid	Valid	Do not use
10	Valid	Valid	Valid	Do not use

##### **Input Mode 0: Input Has No Action**

In Input mode 0, the inputs do not affect the outputs, but they can still trigger captures and interrupts if enabled.

**Figure 23-10. Input Mode 0**

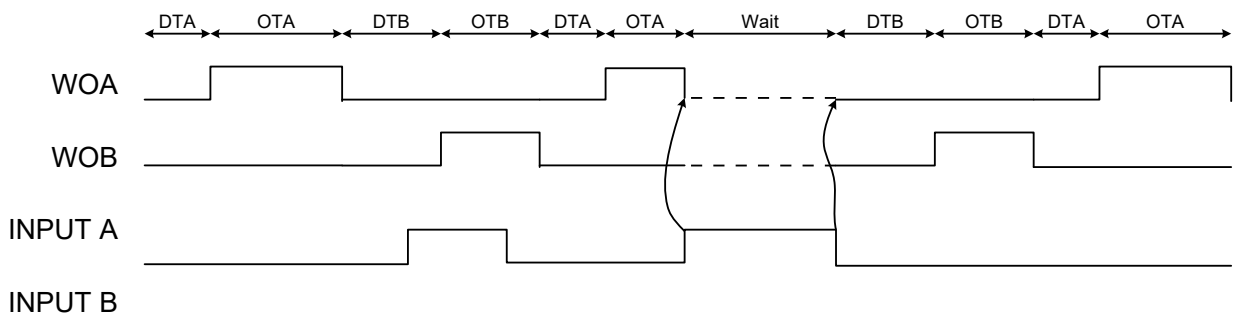


**Input Mode 1: Stop Output, Jump to Opposite Compare Cycle, and Wait**

An input event in Input mode 1 will stop the output signal, jump to the opposite dead time, and wait until the input event goes low before the TCD counter continues.

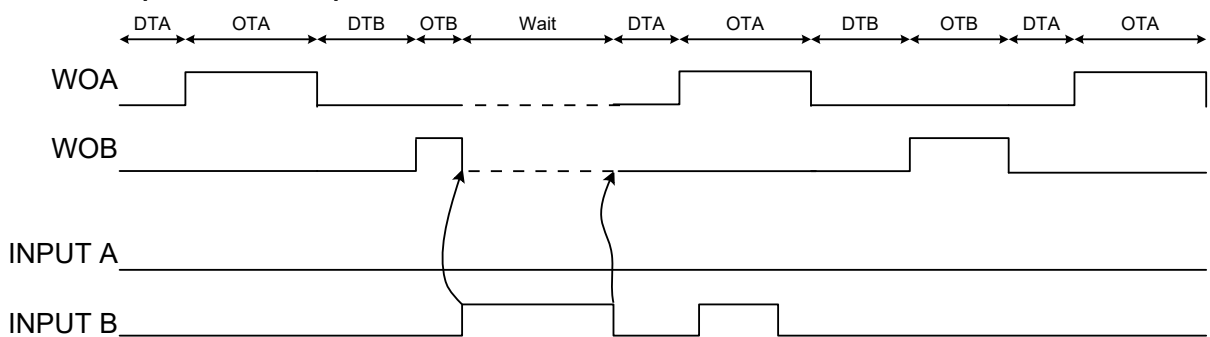
If Input mode 1 is used on input A, an event will only have an effect if the TCD is in dead time A or on time A, and it will only affect the WOA output. When the event is done, the TCD counter starts at dead time B.

**Figure 23-11. Input Mode 1 on Input A**



If Input mode 1 is used on input B, an event will only have an effect if the TCD is in dead time B or on time B, and it will only affect the WOB output. When the event is done, the TCD counter starts at dead time A.

**Figure 23-12. Input Mode 1 on Input B**



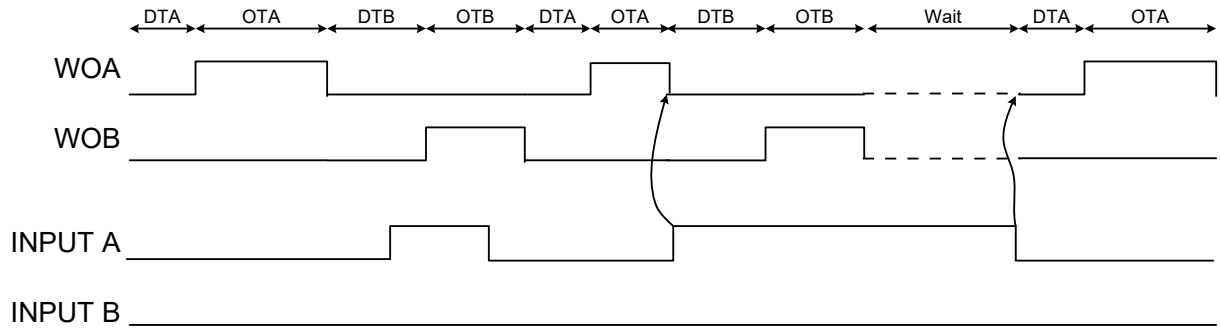
**Input Mode 2: Stop Output, Execute Opposite Compare Cycle, and Wait**

An input event in Input mode 2 will stop the output signal, execute to the opposite dead time and on time, and then wait until the input event goes low before the TCD counter continues. If the input is done before the opposite dead time and on time have finished, there will be no waiting, but the opposite dead time and on time will continue.

If Input mode 2 is used on input A, an event will only have an effect if the TCD is in dead time A or on time A, and will only affect the WOA output.

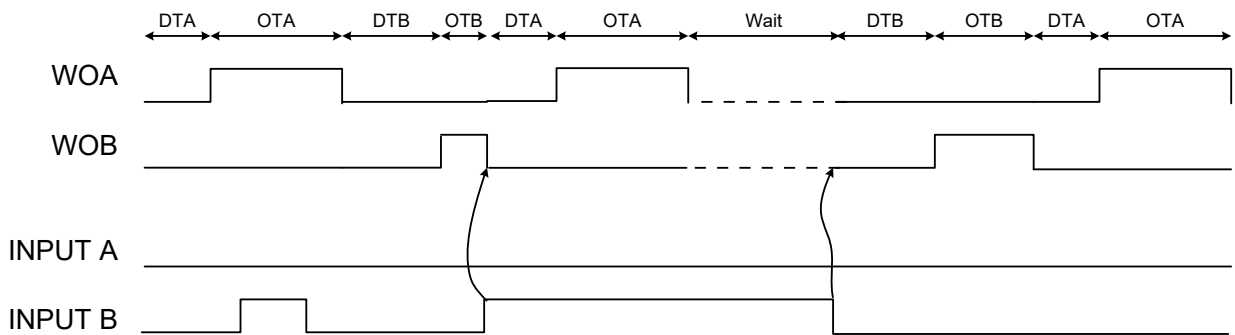


Figure 23-13. Input Mode 2 on Input A



If Input mode 2 is used on input B, an event will only have an effect if the TCD is in dead time B or on time B, and it will only affect the WOB output.

Figure 23-14. Input Mode 2 on Input B

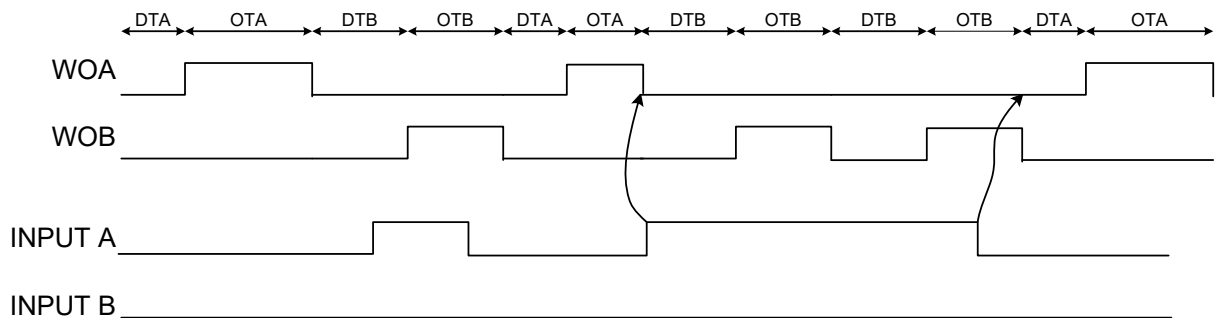


**Input Mode 3: Stop Output, Execute Opposite Compare Cycle while Fault Active**

An input event in Input mode 3 will stop the output signal and start executing the opposite dead time and on time repetitively, as long as the Fault/input is active. When the input is released, the ongoing dead time and/or on time will finish, and then the normal flow will start.

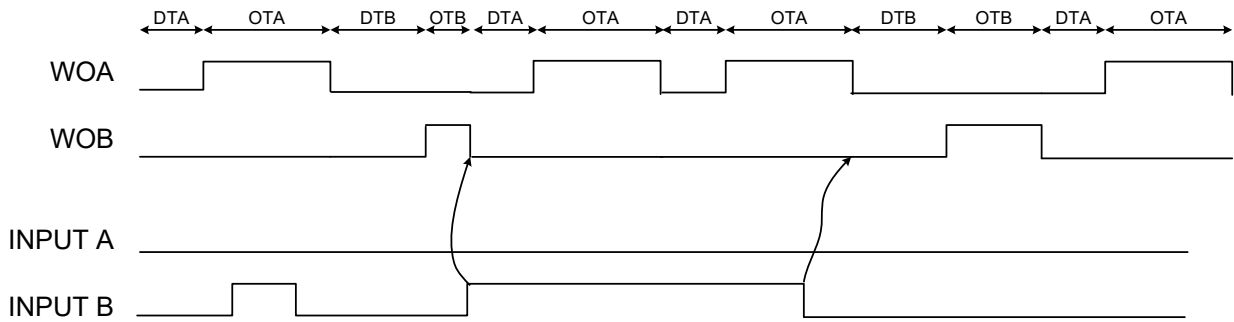
If Input mode 3 is used on input A, an event will only have an effect if the TCD is in dead time A or on time A.

Figure 23-15. Input Mode 3 on Input A



If Input mode 3 is used on input B, an event will only have an effect if the TCD is in dead time B or on time B.

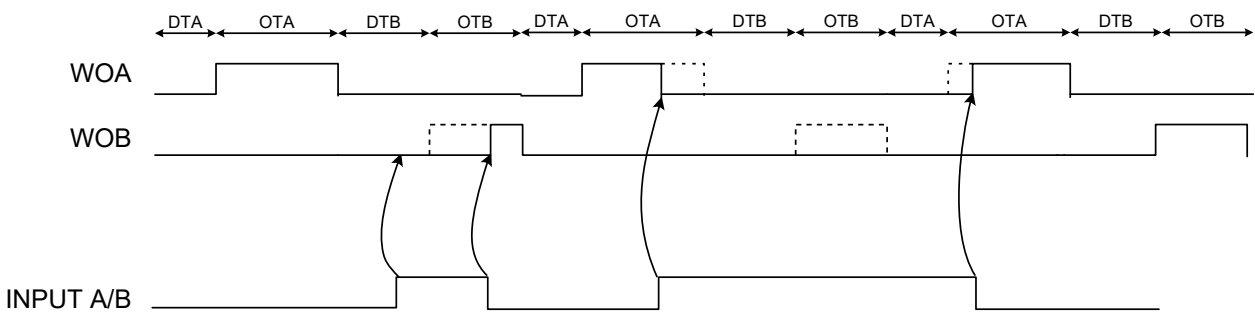
Figure 23-16. Input Mode 3 on Input B



**Input Mode 4: Stop all Outputs, Maintain Frequency**

When Input mode 4 is used, both input A and input B will give the same functionality. An input event will deactivate the outputs as long as the event is active. The TCD counter will not be affected by events in this input mode.

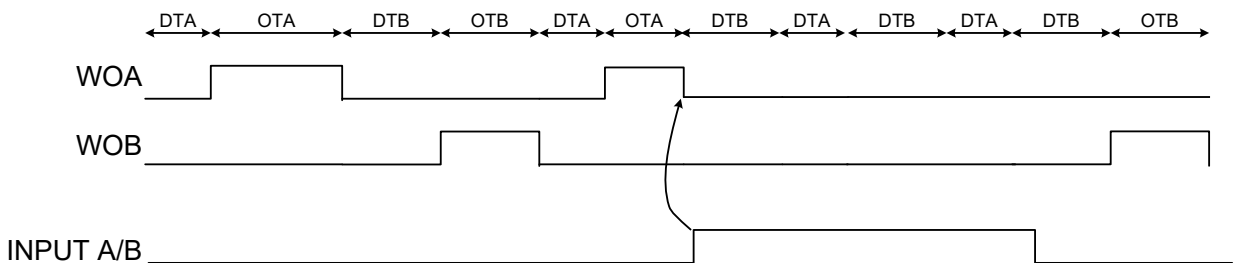
Figure 23-17. Input Mode 4



**Input Mode 5: Stop all Outputs, Execute Dead Time while Fault Active**

When Input mode 5 is used, both input A and input B give the same functionality. The input event stops the outputs and starts on the opposite dead time if it occurs during an on time. If the event occurs during dead time, the dead time will continue until the next on time is scheduled to start. Though, if the input is still active, the cycle will continue with the other dead time. As long as the input event is active, alternating dead times will occur. When the input event stops, the ongoing dead time will finish, and the next on time will continue in the normal flow.

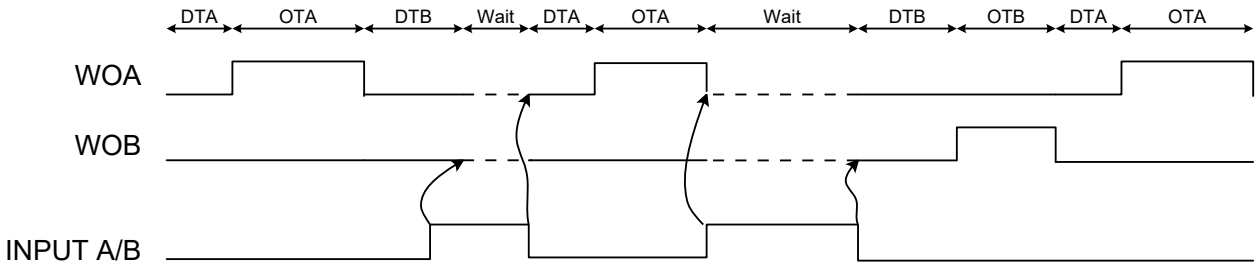
Figure 23-18. Input Mode 5



**Input Mode 6: Stop All Outputs, Jump to Next Compare Cycle, and Wait**

When Input mode 6 is used, both input A and input B will give the same functionality. The input event stops the outputs and jumps to the opposite dead time if it occurs during an on time. If the event occurs during dead time, the dead time will continue until the next on time is scheduled to start. As long as the input event is active, the TCD counter will wait. When the input event stops, the next dead time will start, and normal flow will continue.

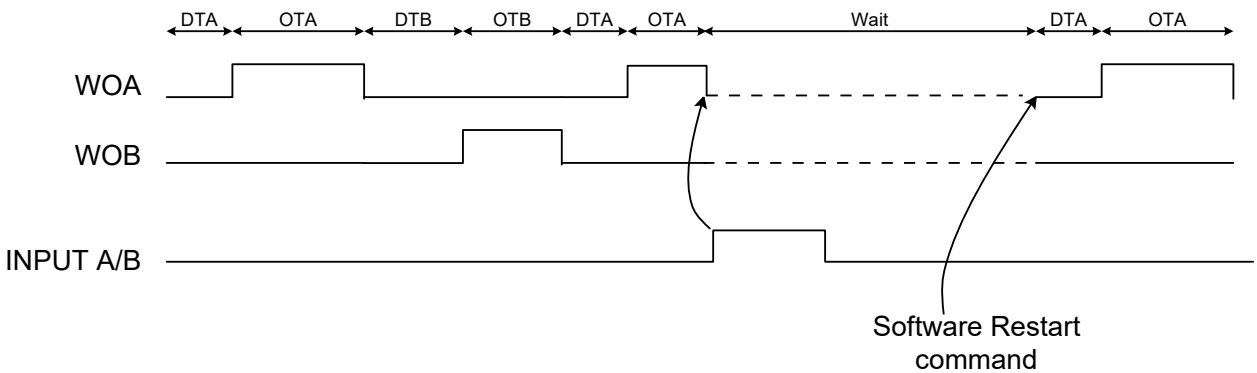
Figure 23-19. Input Mode 6



**Input Mode 7: Stop all Outputs, Wait for Software Action**

When Input mode 7 is used, both input A and input B will give the same functionality. The input events stop the outputs and the TCD counter. It will be stopped until a Restart command is given. If the input event is still high when the Restart command (RESTART bit in TCDn.CTRLB register) is given, it will stop again. When the TCD counter restarts, it will always start on dead time A.

Figure 23-20. Input Mode 7

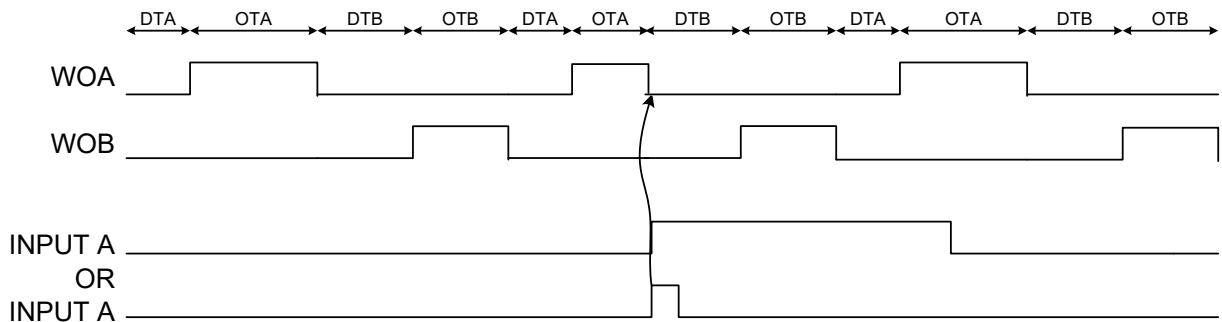


**Input Mode 8: Stop Output on Edge, Jump to Next Compare Cycle**

In Input mode 8, a positive edge on the input event while the corresponding output is ON will cause the output to stop and the TCD counter to jump to the opposite dead time.

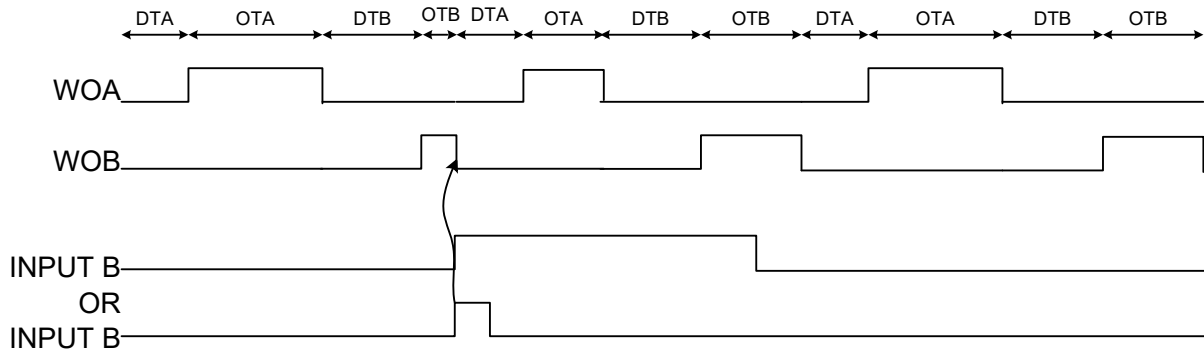
If Input mode 8 is used on input A and a positive edge on the input event occurs while in on time A, the TCD counter jumps to dead time B.

Figure 23-21. Input Mode 8 on Input A



If Input mode 8 is used on input B and a positive edge on the input event occurs while in on time B, the TCD counter jumps to dead time A.

Figure 23-22. Input Mode 8 on Input B

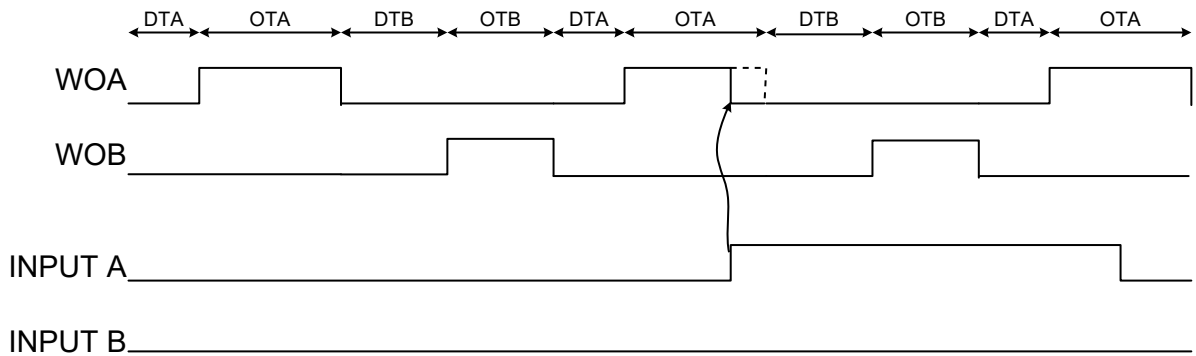


**Input Mode 9: Stop Output on Edge, Maintain Frequency**

In Input mode 9, a positive edge on the input event while the corresponding output is ON will cause the output to stop during the rest of the on time. The TCD counter will not be affected by the event, only the output.

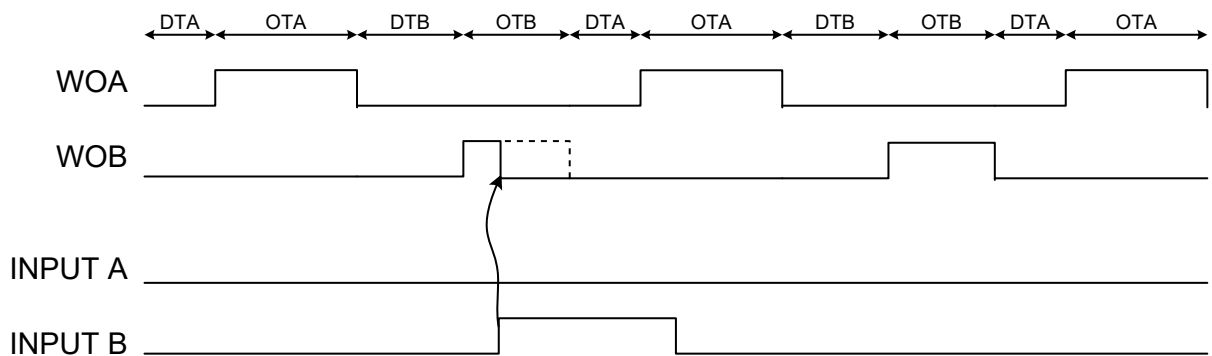
If Input mode 9 is used on input A and a positive edge on the input event occurs while in on time A, the output will be OFF for the rest of the on time.

Figure 23-23. Input Mode 9 on Input A



If Input mode 9 is used on input B and a positive edge on the input event occurs while in on time B, the output will be OFF for the rest of the on time.

Figure 23-24. Input Mode 9 on Input B

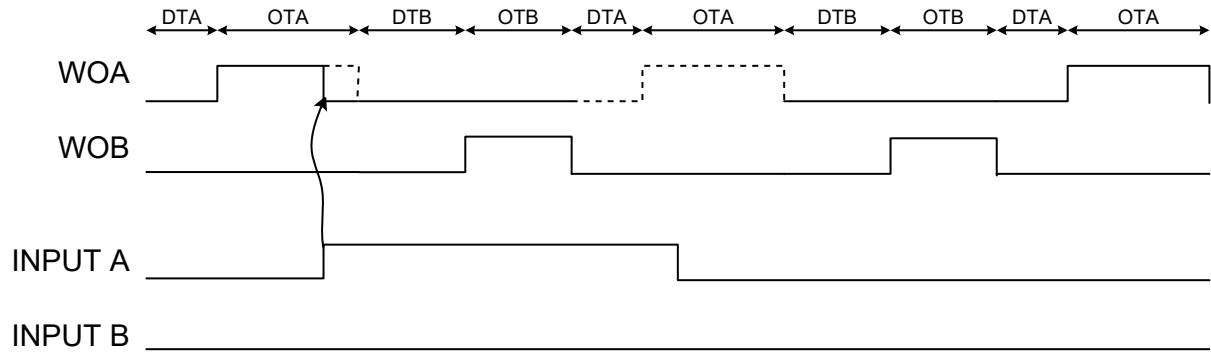


**Input Mode 10: Stop Output at Level, Maintain Frequency**

In Input mode 10, the input event will cause the corresponding output to stop, as long as the input is active. If the input goes low while there must have been an on time on the corresponding output, the output will be deactivated for the rest of the on time. The TCD counter is not affected by the event, only the output.

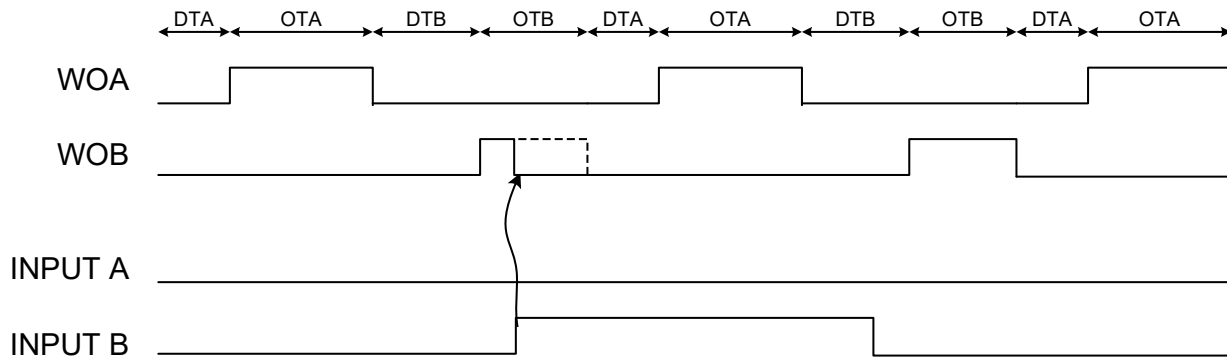
If Input mode 10 is used on input A and an input event occurs, the WOA will be OFF as long as the event lasts. If released during an on time, it will be OFF for the rest of the on time.

Figure 23-25. Input Mode 10 on Input A



If Input mode 10 is used on input B and an input event occurs, the WOB will be OFF as long as the event lasts. If released during an on time, it will be OFF for the rest of the on time.

Figure 23-26. Input Mode 10 on Input B



**Input Mode Summary**

Table 23-6 summarizes the conditions, as illustrated in the timing diagrams of the preceding sections.

Table 23-6. Input Mode Summary

INPUTMODE	Trigger → Output Affected	Fault On/Active	Fault Release/Inactive
0	-	No action	No action
1	Input A→WOA	End the current on time and wait	Start with dead time for the other compare
	Input B→WOB		
2	Input A→WOA	End the current on time, execute the other compare cycle and wait	Start with dead time for the current compare
	Input B→WOB		
3	Input A→WOA	Execute the current on time, then execute the other compare cycle repetitively	Re-enable the current compare cycle
	Input B→WOB		
4	Input A→{WOA, WOB}	Deactivate the outputs	
	Input B→{WOA, WOB}		
5	Input A→{WOA, WOB}	Execute dead time only	
	Input B→{WOA, WOB}		
6	Input A→{WOA, WOB}	End on time and wait	Start with dead time for the other compare
	Input B→{WOA, WOB}		

.....continued

INPUTMODE	Trigger → Output Affected	Fault On/Active	Fault Release/Inactive
7	Input A→{WOA, WOB}	End on time and wait for software action	Start with dead time for the current compare
	Input B→{WOA, WOB}		
8	Input A→WOA	End the current on time and continue with the other off time	
	Input B→WOB		
9	Input A→WOA	Block the current on time and continue the sequence	
	Input B→WOB		
10	Input A→WOA	Deactivate on time until the end of the sequence while the trigger is active	
	Input B→WOB		
other	-	-	-

**Note:** When using different modes on each event input, take into consideration possible conflicts, keeping in mind that TCD has a single counter, to avoid unexpected results.

### 23.3.3.5 Dithering

If it is not possible to achieve the desired frequency because of the prescaler/period selection limitations, dithering can be used to approximate the desired frequency and reduce the waveform drift.

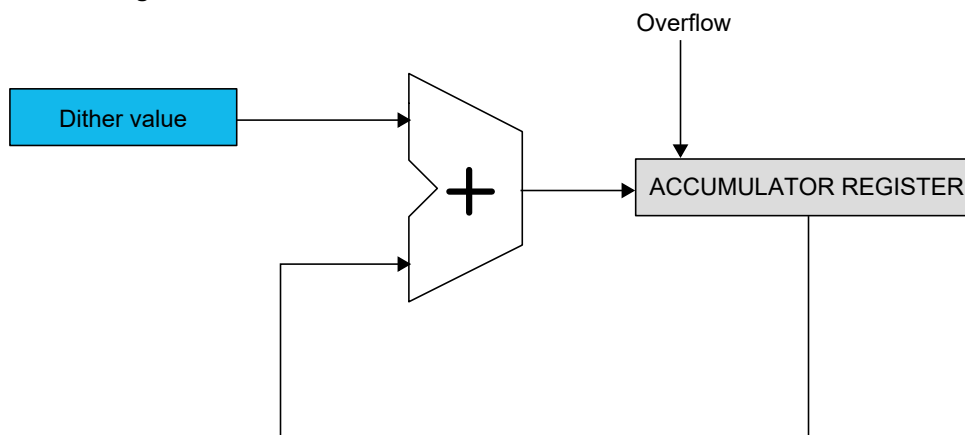
The dither accumulates the fractional error of the counter clock for each cycle. When the fractional error overflows, an additional clock cycle is added to the selected part of the TCD cycle.

**Example 23-1. Generate 75 kHz from a 10 MHz Clock**

If the timer clock frequency is 10 MHz, it will give the timer a resolution of 100 ns. The desired output frequency is 75 kHz, which means a period of 13333 ns. This period cannot be achieved with a 100 ns resolution as it would require 133.33 cycles. The output period can be set to either 133 cycles (75.188 kHz) or 134 cycles (74.626 kHz).

It is possible to change the period between the two frequencies manually in the firmware to get an average output frequency of 75 kHz (change every third period to 134 cycles). The dither can do this automatically by accumulating the error (0.33 cycles). The accumulator calculates when the accumulated error is larger than one clock cycle. When that happens, an additional cycle is added to the timer period.

**Figure 23-27. Dither Logic**



The user can select where in the TCD cycle the dither will be added by writing to the Dither Selection (DITHERSEL) bits in the Dither Control (TCDn.DITCTRL) register:

- On time B
- On time A and B
- Dead time B
- Dead time A and B

How much the dithering will affect the TCD cycle time depends on what Waveform Generation mode is used (see [Table 23-7](#)). Dithering is not supported in Dual Slope mode.

**Table 23-7. Mode-Dependent Dithering Additions to TCD Cycle**

WAVEGEN	DITHERSEL in TCDn.DITCTRL	Additional TCD Clock Cycles to TCD Cycle
One Ramp mode	On time B	1
	On time A and B	1
	Dead time B	0
	Dead time A and B	0
Two Ramp mode	On time B	1
	On time A and B	2
	Dead time B	0
	Dead time A and B	0
Four Ramp mode	On time B	1
	On time A and B	2
	Dead time B	1
	Dead time A and B	2
Dual Slope mode	On time B	Not supported
	On time A and B	Not supported
	Dead time B	Not supported
	Dead time A and B	Not supported

The differences in the number of TCD clock cycles added to the TCD cycle are caused by the different number of compare values used by the TCD cycle. For example, in One Ramp mode, only CMPBCLR affects the TCD cycle time.

For DITHERSEL configurations where no extra cycles are added to the TCD cycles, compensation is reached by shortening the following output state.

**Example 23-2. DITHERSEL in One Ramp Mode**

In One Ramp mode with DITHERSEL selecting dead time B, the dead time B will be increased by one cycle when dither overflow occurs, reducing on time B by one cycle.

**23.3.3.6 TCD Counter Capture**

The TCD counter is asynchronous to the peripheral clock, so it is not possible to read out the counter value directly. It is possible to capture the TCD counter value, synchronized to the I/O clock domain, in two ways:

- Capture value on input events
- Software capture

The capture logic contains two separate capture blocks, CAPTUREA and CAPTUREB, that can capture and synchronize the TCD counter value to the I/O clock domain. CAPTUREA/B can be triggered by input event A/B or by software.

The capture values can be obtained by reading first TCDn.CAPTUREAL/TCDn.CAPTUREBL and then TCDn.CAPTUREAH/TCDn.CAPTUREBH registers.

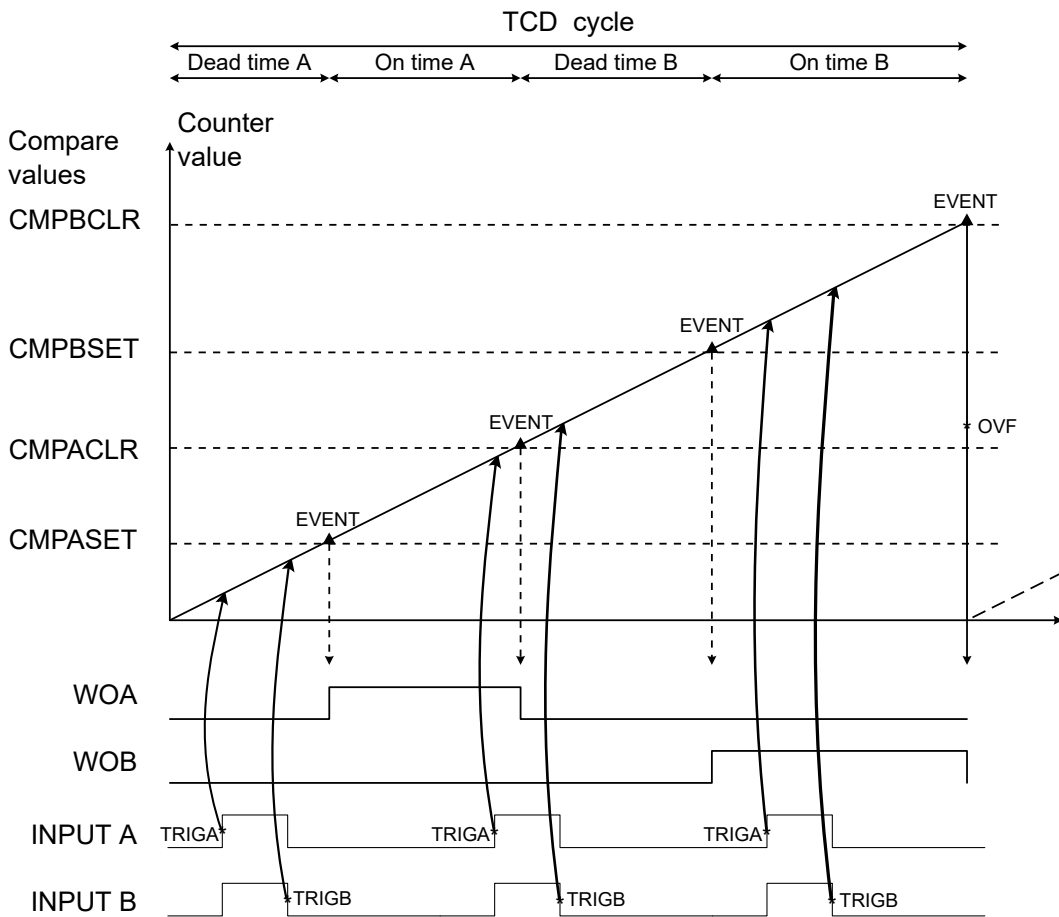
### Captures Triggered by Input Events

To enable the capture on an input event, write a '1' to the ACTION bit in the respective Event Control (TCDn.EVCTRLA or TCDn.EVCTRLB) register when configuring an event input.

When a capture has occurred, the TRIGA/B flag is raised in the Interrupt Flags (TCDn.INTFLAGS) register. The corresponding TRIGA/B interrupt can be enabled by writing a '1' to the respective Trigger Interrupt Enable (TRIGA or TRIGB) bit in the Interrupt Control (TCDn.INTCTRL) register. By polling TRIGA or TRIGB in TCDn.INTFLAGS, the user knows that a CAPTURE value is available, and can read out the value by reading first the TCDn.CAPTUREAL or TCDn.CAPTUREBL register and then the TCDn.CAPTUREAH or TCDn.CAPTUREBH register.

#### Example 23-3. PWM Capture

To perform a PWM capture, connect both event A and event B to the same asynchronous event channel that contains the PWM signal. To get information on the PWM signal, configure one event input to capture the rising edge of the signal. Configure the other event input to capture the falling edge of the signal.



**Note:**

▲ Event trigger

\* Interrupt trigger

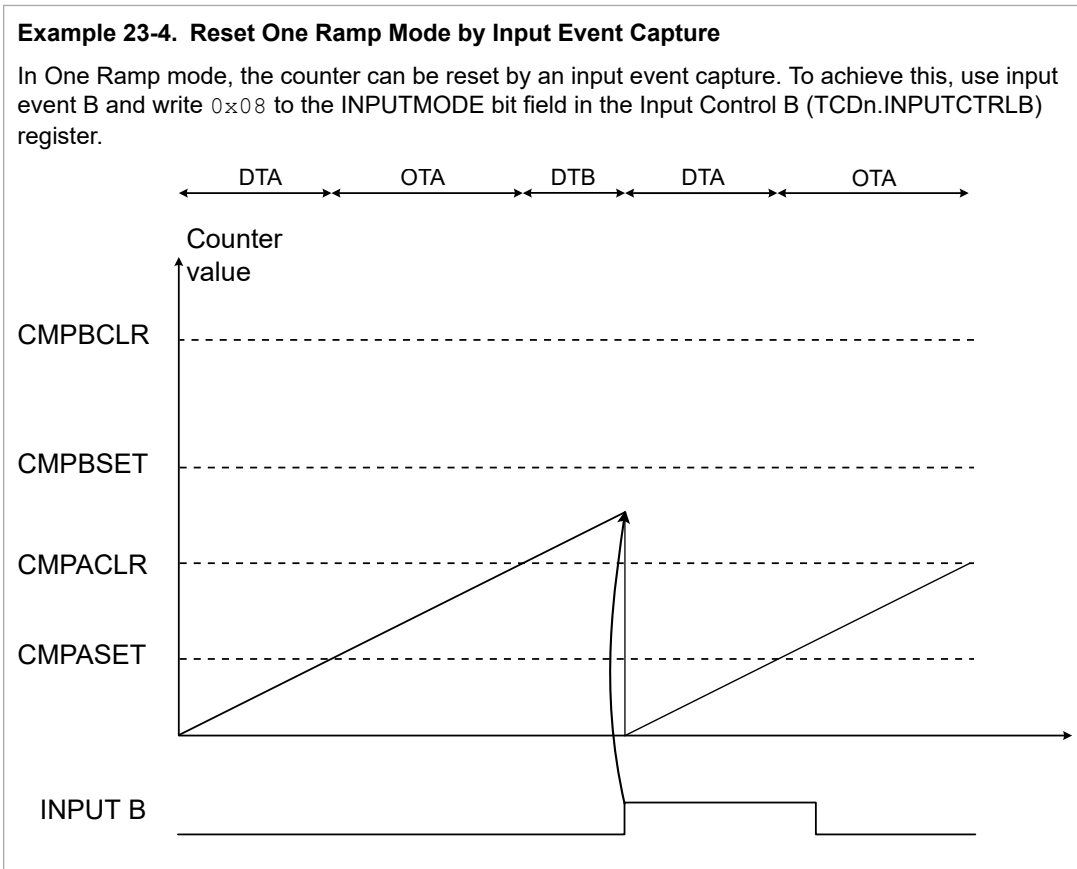


**Capture Triggered by Software**

The software can capture the TCD value by writing a '1' to the respective Software Capture A/B Strobe (SCAPTUREx) bit in the Control E (TCDn.CTRLE) register. When this command is executed and the Command Ready (CMDRDY) bit in the Status (TCDn.STATUS) register reads '1' again, the CAPTUREA/B value is available. It can now be read by reading first the TCDn.CAPTUREAL or TCDn.CAPTUREBL register and then the TCDn.CAPTUREAH or TCDn.CAPTUREBH register.

**Using Capture Together with Input Modes**

The capture functionality can be used together with input modes. The same event will then both capture the counter value and trigger a change in the counter flow, depending on the input mode selected.



**23.3.3.7 Output Control**

The outputs are configured by writing to the Fault Control (TCDn.FAULTCTRL) register.

The Compare x Enable (CMPxEN) bits in TCDn.FAULTCTRL enable the different outputs. The CMPx bits in TCDn.FAULTCTRL set the output values when a Fault is triggered.

The TCD itself generates two different outputs, WOA and WOB. The two additional outputs, WOC and WOD, can be configured by software to be connected to either WOA or WOB by writing the Compare C/D Output Select (CMPCSEL and CMPDSEL) bits in the Control C (TCDn.CTRL C) register.

The user can override the outputs based on the TCD counter state by writing a '1' to the Compare Output Value Override (CMPOVR) bit in the Control C (TCDn.CTRL C) register. The user can then select the output values in the different dead and on times by writing to the Compare Value (CMPAVAL and CMPBVAL) bit fields in the Control D (TCDn.CTRL D) register.

When used in One Ramp mode, WOA will only use the setup for dead time A (DTA) and on time A (OTA) to set the output. WOB will only use dead time B (DTB) and on time B (OTB) values to set the output.

When using the override feature together with Faults detection (input modes), the CMPA (and CMPC/D if WOC/D equals WOA) bit in TCDn.FAULTCTRL must be equal to CMPAVAL[0] and [2] in CTRL. If not, the first cycle after a

Fault is detected can have the wrong polarity on the outputs. The same applies to CMPB in the TCDn.FAULTCTRL (and CMPC/D if WOC/D equals WOB) bit, which must be equal to CMPBVAL[0] and [2] in TCDn.CTRLD.

Due to the asynchronous nature of the TCD and that input events can immediately affect the output signal, there is a risk of nanosecond spikes occurring on the output without any load on the pin. The case occurs in any input mode different from '0' and when an input event is triggering. The spike value will always be in the direction of the CMPx values given by the TCDn.FAULTCTRL register.

### 23.3.4 Events

The TCD can generate the events described in the following table:

**Table 23-8. Event Generators in TCD**

Generator Name		Description	Event Type	Generating Clock Domain	Length of Event
Peripheral	Event				
TCDn	CMPBCLR	The counter matches CMPBCLR	Pulse	CLK_TCD	One CLK_TCD_CNT period
	CMPASET	The counter matches CMPASET			
	CMPBSET	The counter matches CMPBSET			
	PROGEV	Programmable event output <sup>(1)</sup>			One CLK_TCD_SYNC period

**Note:**

1. The user can select the trigger and all the compare matches (including CMPACLR). Also, it is possible to delay the output event from 0 to 255 TCD delay cycles.

The three events based on the counter match directly generate event strobes that last for one clock cycle on the TCD counter clock. The programmable output event generates an event strobe that lasts for one clock cycle on the TCD synchronizer clock.

The TCD can receive the events described in the following table:

**Table 23-9. Event Users and Available Event Actions in TCD**

User Name		Description	Input Detection	Async/Sync
Peripheral	Input			
TCDn	Input A/ Input B	Stop the output, jump to the opposite compare cycle and wait.	Level	Both
		Stop the output, execute the opposite compare cycle and wait.		
		Stop the output, execute the opposite compare cycle while the Fault is active.		
		Stop all outputs, maintain the frequency.		
		Stop all outputs, execute dead time while the Fault is active.		
		Stop all outputs, jump to the next compare cycle and wait.		
		Stop all outputs, wait for software action.		
		Stop the output on the edge, jump to the next compare cycle.	Edge	
		Stop the output on the edge, maintain the frequency.		
		Stop the output at level, maintain the frequency.	Level	

Input A and Input B are TCD event users that detect and act upon the input events. Additional information about input events and how to configure them can be found in the [23.3.3.4 TCD Inputs](#) section. Refer to the Event System (EVSYS) section for more details regarding event types and Event System configuration.

### 23.3.4.1 Programmable Output Events

The Programmable Output Event (PROGEV) uses the same logic as the input blanking for trigger selection and delay. Therefore, it is not possible to configure the functionalities independently. If the input blanking functionality is used, the output event cannot be delayed, and the trigger used for input blanking will also be used for the output event.

PROGEV is configured in the TCDn.DLYCTRL and TCDn.DLYVAL registers. It is possible to delay the output event by 0 to 255 TCD delay clock cycles. The delayed output event functionality uses the TCD delay clock and counts until the DLYVAL value is reached before the trigger is sent out as an event. The TCD delay clock is a prescaled version of the TCD synchronizer clock (CLK\_TCD\_SYNC), and the division factor is set by the DLYPRESC bits in the TCDn.DLYCTRL register. The output event will be delayed by the TCD clock period x DLYPRESC division factor x DLYVAL.

### 23.3.5 Interrupts

**Table 23-10. Available Interrupt Vectors and Sources**

Name	Vector Description	Conditions
OVF	Overflow interrupt	The TCD finishes one TCD cycle
TRIG	Trigger interrupt	<ul style="list-style-type: none"> <li>• TRIGA: On event input A</li> <li>• TRIGB: On event input B</li> </ul>

When an interrupt condition occurs, the corresponding interrupt flag is set in the Interrupt Flags (TCDn.INTFLAGS) register.

An interrupt source is enabled or disabled by writing to the corresponding enable bit in the Interrupt Control (TCDn.INTCTRL) register.

An interrupt request is generated when the corresponding interrupt source is enabled, and the interrupt flag is set. The interrupt request remains active until the interrupt flag is cleared. See the peripheral's INTFLAGS register for details on how to clear interrupt flags.

When several interrupt request conditions are supported by an interrupt vector, the interrupt requests are ORed together into one combined interrupt request to the interrupt controller. The user must read the peripheral's INTFLAGS register to determine which of the interrupt conditions are present.

### 23.3.6 Sleep Mode Operation

The TCD operates in Idle sleep mode and is stopped when entering Standby and Power-Down sleep modes.

### 23.3.7 Debug Operation

Halting the CPU in Debugging mode will halt the normal operation of the peripheral. This peripheral can be forced to operate with the CPU halted by writing a '1' to the Debug Run (DBG RUN) bit in the Debug Control (TCDn.DBGCTRL) register.

When the Fault Detection (FAULTDET) bit in TCDn.DBGCTRL is written to '1', and the CPU is halted in Debug mode, an event/Fault is created on both input event channels. These events/Faults last as long as the break and can serve as a safeguard in Debug mode, for example, by forcing external components off.

If the peripheral is configured to require periodic service by the CPU through interrupts or similar, improper operation or data loss may result during halted debugging.

### 23.3.8 Configuration Change Protection

This peripheral has registers that are under Configuration Change Protection (CCP). To write to these registers, a certain key must first be written to the CPU.CCP register, followed by a write access to the protected bits within four CPU instructions.

Attempting to write to a protected register without following the appropriate CCP unlock sequence leaves the protected register unchanged.

The following registers are under CCP:

**Table 23-11. Registers under Configuration Change Protection in TCD**

Register	Key
TCDn.FAULTCTRL	IOREG

## 23.4 Register Summary

Offset	Name	Bit Pos.	7	6	5	4	3	2	1	0
0x00	<a href="#">CTRLA</a>	7:0		CLKSEL[1:0]		CNTPRES[1:0]		SYNCPRES[1:0]		ENABLE
0x01	<a href="#">CTRLB</a>	7:0						WGMODE[1:0]		
0x02	<a href="#">CTRLC</a>	7:0	CMPDSEL	CMPCSEL			FIFTY		AUPDATE	CMPOVR
0x03	<a href="#">CTRLD</a>	7:0	CMPBVAL[3:0]			CMPAVAL[3:0]				
0x04	<a href="#">CTRL E</a>	7:0	DISEOC			SCAPTUREB	SCAPTUREA	RESTART	SYNC	SYNCEOC
0x05	...									
0x07	Reserved									
0x08	<a href="#">EVCTRLA</a>	7:0	CFG[1:0]			EDGE		ACTION		TRIGEI
0x09	<a href="#">EVCTRLB</a>	7:0	CFG[1:0]			EDGE		ACTION		TRIGEI
0x0A	...									
0x0B	Reserved									
0x0C	<a href="#">INTCTRL</a>	7:0					TRIGB	TRIGA		OVF
0x0D	<a href="#">INTFLAGS</a>	7:0					TRIGB	TRIGA		OVF
0x0E	<a href="#">STATUS</a>	7:0	PWMACTB	PWMACTA					CMDRDY	ENRDY
0x0F	Reserved									
0x10	<a href="#">INPUTCTRLA</a>	7:0					INPUTMODE[3:0]			
0x11	<a href="#">INPUTCTRLB</a>	7:0					INPUTMODE[3:0]			
0x12	<a href="#">FAULTCTRL</a>	7:0	CMPDxEN	CMPCxEN	CMPBxEN	CMPAxEN	CMPDx	CMPCx	CMPBx	CMPAx
0x13	Reserved									
0x14	<a href="#">DLYCTRL</a>	7:0			DLYPRESC[1:0]		DLYTRIG[1:0]		DLYSEL[1:0]	
0x15	<a href="#">DLYVAL</a>	7:0	DLYVAL[7:0]							
0x16	...									
0x17	Reserved									
0x18	<a href="#">DITCTRL</a>	7:0						DITHERSEL[1:0]		
0x19	<a href="#">DITVAL</a>	7:0					DITHER[3:0]			
0x1A	...									
0x1D	Reserved									
0x1E	<a href="#">DBGCTRL</a>	7:0						FAULTDET		DBGRUN
0x1F	...									
0x21	Reserved									
0x22	<a href="#">CAPTUREA</a>	7:0	CAPTUREA[7:0]							
		15:8	CAPTUREA[11:8]							
0x24	<a href="#">CAPTUREB</a>	7:0	CAPTUREB[7:0]							
		15:8	CAPTUREB[11:8]							
0x26	...									
0x27	Reserved									
0x28	<a href="#">CMPASET</a>	7:0	CMPASET[7:0]							
		15:8	CMPASET[11:8]							
0x2A	<a href="#">CMPACLR</a>	7:0	CMPACLR[7:0]							
		15:8	CMPACLR[11:8]							
0x2C	<a href="#">CMPBSET</a>	7:0	CMPBSET[7:0]							
		15:8	CMPBSET[11:8]							
0x2E	<a href="#">CMPBCLR</a>	7:0	CMPBCLR[7:0]							
		15:8	CMPBCLR[11:8]							

## 23.5 Register Description

### 23.5.1 Control A

**Name:** CTRLA  
**Offset:** 0x00  
**Reset:** 0x00  
**Property:** Enable-protected

Bit	7	6	5	4	3	2	1	0
		CLKSEL[1:0]		CNTPRES[1:0]		SYNCPRES[1:0]		ENABLE
Access		R/W	R/W	R/W	R/W	R/W	R/W	R/W
Reset		0	0	0	0	0	0	0

#### Bits 6:5 – CLKSEL[1:0] Clock Select

The Clock Select bits select the clock source of the TCD clock.

Value	Name	Description
0x0	OSCHF	Internal High-Frequency Oscillator
0x1	PLL	PLL
0x2	EXTCLK	External clock
0x3	CLK_PER	Peripheral clock

#### Bits 4:3 – CNTPRES[1:0] Counter Prescaler

The Counter Prescaler bits select the division factor of the TCD counter clock.

Value	Name	Description
0x0	DIV1	Division factor 1
0x1	DIV4	Division factor 4
0x2	DIV32	Division factor 32
0x3	-	Reserved

#### Bits 2:1 – SYNCPRES[1:0] Synchronization Prescaler

The Synchronization Prescaler bits select the division factor of the TCD clock.

Value	Name	Description
0x0	DIV1	Division factor 1
0x1	DIV2	Division factor 2
0x2	DIV4	Division factor 4
0x3	DIV8	Division factor 8

#### Bit 0 – ENABLE Enable

When writing to this bit, it will automatically be synchronized to the TCD clock domain.

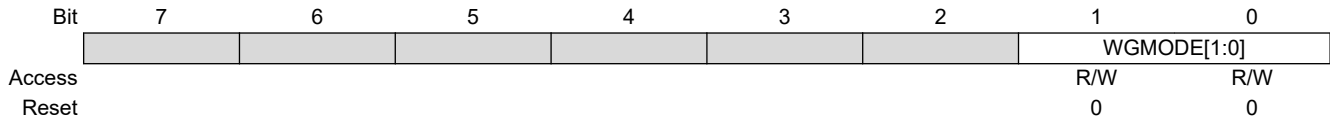
This bit can be changed as long as the synchronization of this bit is not ongoing. See the Enable Ready (ENRDY) bit in the Status (TCDn.STATUS) register.

This bit is not enable-protected.

Value	Name	Description
0	NO	The TCD is disabled.
1	YES	The TCD is enabled and running.

**23.5.2 Control B**

**Name:** CTRLB  
**Offset:** 0x01  
**Reset:** 0x00  
**Property:** -



**Bits 1:0 – WGMODE[1:0]** Waveform Generation Mode  
 These bits select the waveform generation.

Value	Name	Description
0x0	ONERAMP	One Ramp mode
0x1	TWORAMP	Two Ramp mode
0x2	FOURRAMP	Four Ramp mode
0x3	DS	Dual Slope mode

**23.5.3 Control C**

**Name:** CTRLC  
**Offset:** 0x02  
**Reset:** 0x00  
**Property:** -

	7	6	5	4	3	2	1	0
	CMPDSEL	CMPCSEL			FIFTY		AUPDATE	CMPOVR
Access	R/W	R/W			R/W		R/W	R/W
Reset	0	0			0		0	0

**Bit 7 – CMPDSEL** Compare D Output Select  
 This bit selects which waveform will be connected to output D.

Value	Name	Description
0	PWMA	Waveform A
1	PWMB	Waveform B

**Bit 6 – CMPCSEL** Compare C Output Select  
 This bit selects which waveform will be connected to output C.

Value	Name	Description
0	PWMA	Waveform A
1	PWMB	Waveform B

**Bit 3 – FIFTY** Fifty Percent Waveform  
 If the two waveforms have identical characteristics, this bit can be written to '1'. This will cause any values written to the TCDn.CMPBSET/TCDn.CLR register to also be written to the TCDn.CMPASET/TCDn.CLR register.

**Bit 1 – AUPDATE** Automatically Update  
 If this bit is written to '1', synchronization at the end of the TCD cycle is automatically requested after the Compare B Clear High (TCDn.CMPBCLR) register is written.  
 If the fifty percent waveform is enabled by setting the FIFTY bit in this register, writing the Compare A Clear High register will also request a synchronization at the end of the TCD cycle if the AUPDATE bit is set.

**Bit 0 – CMPOVR** Compare Output Value Override  
 When this bit is written to '1', default values of the Waveform Outputs A and B are overridden by the values written in the Compare x Value in Active state bit fields in the Control D register. See the [23.5.4 CTRLD](#) register description for more details.



**23.5.4 Control D**

**Name:** CTRLD  
**Offset:** 0x03  
**Reset:** 0x00  
**Property:** -

	Bit	7	6	5	4	3	2	1	0
		CMPBVAL[3:0]				CMPAVAL[3:0]			
Access		R/W	R/W	R/W	R/W	R/W	R/W	R/W	R/W
Reset		0	0	0	0	0	0	0	0

**Bits 0:3, 4:7 – CMPVAL** Compare x Value (in Active state)

These bits set the logical value of the PWMx signal for the corresponding states in the TCD cycle.

These settings are valid only if the Compare Output Value Override (CMPOVR) bit in the Control C (TCDn.CTRLC) register is written to '1'.

**Table 23-12. Two and Four Ramp Mode**

CMPxVAL	DTA	OTA	DTB	OTB
PWMA	CMPAVAL[0]	CMPAVAL[1]	CMPAVAL[2]	CMPAVAL[3]
PWMB	CMPBVAL[0]	CMPBVAL[1]	CMPBVAL[2]	CMPBVAL[3]

When used in One Ramp mode, WOA will only use the setup for dead time A (DTA) and on time A (OTA) to set the output. WOB will only use dead time B (DTB) and on time B (OTB) values to set the output.

**Table 23-13. One Ramp Mode**

CMPxVAL	DTA	OTA	DTB	OTB
PWMA	CMPAVAL[1]	CMPAVAL[0]	-	-
PWMB	-	-	CMPBVAL[3]	CMPBVAL[2]

### 23.5.5 Control E

**Name:** CTRLA  
**Offset:** 0x04  
**Reset:** 0x00  
**Property:** -

	7	6	5	4	3	2	1	0
	DISEOC			SCAPTUREB	SCAPTUREA	RESTART	SYNC	SYNCEOC
Access	R/W			R/W	R/W	R/W	R/W	R/W
Reset	0			0	0	0	0	0

**Bit 7 – DISEOC** Disable at End of TCD Cycle Strobe

When this bit is written to '1', the TCD will automatically disable at the end of the TCD cycle.

Note that ENRDY in TCDn.STATUS will stay low until the TCD is disabled.

Writing to this bit has effect only if there is no ongoing synchronization of the ENABLE value in TCDn.CTRLA with the TCD domain. See also the ENRDY bit in TCDn.STATUS.

**Bit 4 – SCAPTUREB** Software Capture B Strobe

When this bit is written to '1', a software capture to the Capture B (TCDn.CAPTUREBL/H) register is triggered as soon as synchronization to the TCD clock domain occurs.

Writing to this bit has effect only if there is no ongoing synchronization of a command. See also the CMDRDY bit in TCDn.STATUS.

**Bit 3 – SCAPTUREA** Software Capture A Strobe

When this bit is written to '1', a software capture to the Capture A (TCDn.CAPTUREAL/H) register is triggered as soon as synchronization to the TCD clock domain occurs.

Writing to this bit has effect only if there is no ongoing synchronization of a command. See also the CMDRDY bit in TCDn.STATUS.

**Bit 2 – RESTART** Restart Strobe

When this bit is written to '1', a restart of the TCD counter is executed as soon as this bit is synchronized to the TCD domain.

Writing to this bit has effect only if there is no ongoing synchronization of a command. See also the CMDRDY bit in TCDn.STATUS.

**Bit 1 – SYNC** Synchronize Strobe

When this bit is written to '1', the double-buffered registers will be loaded to the TCD domain as soon as this bit is synchronized to the TCD domain.

Writing to this bit has effect only if there is no ongoing synchronization of a command. See also the CMDRDY bit in TCDn.STATUS.

**Bit 0 – SYNCEOC** Synchronize End of TCD Cycle Strobe

When this bit is written to '1', the double-buffered registers will be loaded to the TCD domain at the end of the next TCD cycle.

Writing to this bit has effect only if there is no ongoing synchronization of a command. See also the CMDRDY bit in TCDn.STATUS.

### 23.5.6 Event Control A

**Name:** EVCTRLA  
**Offset:** 0x08  
**Reset:** 0x00  
**Property:** -

	7	6	5	4	3	2	1	0
	CFG[1:0]			EDGE		ACTION		TRIGEI
Access	R/W	R/W		R/W		R/W		R/W
Reset	0	0		0		0		0

#### Bits 7:6 – CFG[1:0] Event Configuration

When the input capture noise canceler is activated (FILTERON), the event input is filtered. The filter function requires four successive equal valued samples of the trigger pin to change its output. The input capture is, therefore, delayed by four clock cycles when the noise canceler is enabled (FILTERON).

When the Asynchronous Event is enabled (ASYNCON), the event input will affect the output directly.

Value	Name	Description
0x0	NEITHER	Neither filter nor asynchronous event is enabled.
0x1	FILTERON	Input capture noise cancellation filter enabled.
0x2	ASYNCON	Asynchronous event output qualification enabled.
other	-	Reserved.

#### Bit 4 – EDGE Edge Selection

This bit is used to select the active edge or level for the event input.

Value	Name	Description
0	FALL_LOW	The falling edge or low level of the event input triggers a Capture or Fault action.
1	RISE_HIGH	The rising edge or high level of the event input triggers a Capture or Fault action.

#### Bit 2 – ACTION Event Action

This bit enables capturing on the event input. By default, the input will trigger a Fault, depending on the Input Control register's Input mode. It is also possible to trigger a capture on the event input.

Value	Name	Description
0	FAULT	Event triggers a Fault.
1	CAPTURE	Event triggers a Fault and capture.

#### Bit 0 – TRIGEI Trigger Event Input Enable

Writing this bit to '1' enables event as the trigger for input A.

### 23.5.7 Event Control B

**Name:** EVCTRLB  
**Offset:** 0x09  
**Reset:** 0x00  
**Property:** -

	7	6	5	4	3	2	1	0
	CFG[1:0]			EDGE		ACTION		TRIGEI
Access	R/W	R/W		R/W		R/W		R/W
Reset	0	0		0		0		0

#### Bits 7:6 – CFG[1:0] Event Configuration

When the input capture noise canceler is activated (FILTERON), the event input is filtered. The filter function requires four successive equal valued samples of the trigger pin to change its output. The input capture is, therefore, delayed by four clock cycles when the noise canceler is enabled (FILTERON).

When the Asynchronous Event is enabled (ASYNCON), the event input will affect the output directly.

Value	Name	Description
0x0	NEITHER	Neither filter nor asynchronous event is enabled.
0x1	FILTERON	Input capture noise cancellation filter enabled.
0x2	ASYNCON	Asynchronous event output qualification enabled.
other	-	Reserved.

#### Bit 4 – EDGE Edge Selection

This bit is used to select the active edge or level for the event input.

Value	Name	Description
0	FALL_LOW	The falling edge or low level of the event input triggers a Capture or Fault action.
1	RISE_HIGH	The rising edge or high level of the event input triggers a Capture or Fault action.

#### Bit 2 – ACTION Event Action

This bit enables capturing on the event input. By default, the input will trigger a Fault, depending on the Input Control register's Input mode. It is also possible to trigger a capture on the event input.

Value	Name	Description
0	FAULT	Event triggers a Fault.
1	CAPTURE	Event triggers a Fault and capture.

#### Bit 0 – TRIGEI Trigger Event Input Enable

Writing this bit to '1' enables event as a trigger for input B.

**23.5.8 Interrupt Control**

**Name:** INTCTRL  
**Offset:** 0x0C  
**Reset:** 0x00  
**Property:** -

	7	6	5	4	3	2	1	0
					TRIGB	TRIGA		OVF
Access					R/W	R/W		R/W
Reset					0	0		0

**Bit 3 – TRIGB** Trigger B Interrupt Enable  
 Writing this bit to '1' enables the interrupt when trigger input B is received.

**Bit 2 – TRIGA** Trigger A Interrupt Enable  
 Writing this bit to '1' enables the interrupt when trigger input A is received.

**Bit 0 – OVF** Counter Overflow  
 Writing this bit to '1' enables the restart-of-sequence interrupt or overflow interrupt.

### 23.5.9 Interrupt Flags

**Name:** INTFLAGS  
**Offset:** 0x0D  
**Reset:** 0x00  
**Property:** -

	7	6	5	4	3	2	1	0
					TRIGB	TRIGA		OVF
Access					R/W	R/W		R/W
Reset					0	0		0

**Bit 3 – TRIGB** Trigger B Interrupt Flag

The Trigger B Interrupt (TRIGB) flag is set on a Trigger B or Capture B condition. The flag is cleared by writing a '1' to its bit location.

**Bit 2 – TRIGA** Trigger A Interrupt Flag

The Trigger A Interrupt (TRIGA) flag is set on a Trigger A or Capture A condition. The flag is cleared by writing a '1' to its bit location.

**Bit 0 – OVF** Overflow Interrupt Flag

The Overflow Flag (OVF) is set at the end of a TCD cycle. The flag is cleared by writing a '1' to its bit location.

### 23.5.10 Status

**Name:** STATUS  
**Offset:** 0x0E  
**Reset:** 0x00  
**Property:** -

	Bit	7	6	5	4	3	2	1	0
		PWMACTB	PWMACTA					CMDRDY	ENRDY
Access		R/W	R/W					R	R
Reset		0	0					0	0

**Bit 7 – PWMACTB** PWM Activity on B

This bit is set by hardware each time the WOB output toggles from '0' to '1' or from '1' to '0'.  
 This status bit must be cleared by software by writing a '1' to it before new PWM activity can be detected.

**Bit 6 – PWMACTA** PWM Activity on A

This bit is set by hardware each time the WOA output toggles from '0' to '1' or from '1' to '0'.  
 This status bit must be cleared by software by writing a '1' to it before new PWM activity can be detected.

**Bit 1 – CMDRDY** Command Ready

This status bit tells when a command is synced to the TCD domain and the system is ready to receive new commands.

The following actions clear the CMDRDY bit:

1. TCDn.CTRLE SYNCEOC strobe.
2. TCDn.CTRLE SYNC strobe.
3. TCDn.CTRLE RESTART strobe.
4. TCDn.CTRLE SCAPTUREA Capture A strobe.
5. TCDn.CTRLE SCAPTUREB Capture B strobe.
6. TCDn.CTRLC AUPDATE written to '1' and writing to the TCDn.CMPBCLRH register.

**Bit 0 – ENRDY** Enable Ready

This status bit tells when the ENABLE value in TCDn.CTRLA is synced to the TCD domain and is ready to be written to again.

The following actions clear the ENRDY bit:

1. Writing to the ENABLE bit in TCDn.CTRLA.
2. TCDn.CTRLE DISEOC strobe.
3. Going into BREAK in an On-Chip Debugging (OCD) session while the Debug Run (DBGCTRL) bit in TCDn.DBGCTRL is '0'.

### 23.5.11 Input Control A

**Name:** INPUTCTRLA  
**Offset:** 0x10  
**Reset:** 0x00  
**Property:** -

	7	6	5	4	3	2	1	0
	INPUTMODE[3:0]							
Access					R/W	R/W	R/W	R/W
Reset					0	0	0	0

**Bits 3:0 – INPUTMODE[3:0] Input Mode**

Value	Name	Description
0x0	NONE	The input has no action
0x1	JMPWAIT	Stop the output, jump to the opposite compare cycle, and wait
0x2	EXECWAIT	Stop the output, execute the opposite compare cycle, and wait
0x3	EXECFAULT	Stop the output, execute the opposite compare cycle while the Fault is active
0x4	FREQ	Stop all outputs, maintain the frequency
0x5	EXECDT	Stop all outputs, execute dead time while the Fault is active
0x6	WAIT	Stop all outputs, jump to the next compare cycle, and wait
0x7	WAITSW	Stop all outputs, wait for software action
0x8	EDGETRIG	Stop the output on the edge, jump to the next compare cycle
0x9	EDGETRIGFREQ	Stop the output on the edge, maintain the frequency
0xA	LVLTRIGFREQ	Stop the output at level, maintain the frequency



### 23.5.12 Input Control B

**Name:** INPUTCTRLB  
**Offset:** 0x11  
**Reset:** 0x00  
**Property:** -

	7	6	5	4	3	2	1	0
	INPUTMODE[3:0]							
Access					R/W	R/W	R/W	R/W
Reset					0	0	0	0

**Bits 3:0 – INPUTMODE[3:0] Input Mode**

Value	Name	Description
0x0	NONE	The input has no action
0x1	JMPWAIT	Stop the output, jump to the opposite compare cycle, and wait
0x2	EXECWAIT	Stop the output, execute the opposite compare cycle, and wait
0x3	EXECFAULT	Stop the output, execute the opposite compare cycle while the Fault is active
0x4	FREQ	Stop all outputs, maintain the frequency
0x5	EXECDT	Stop all outputs, execute dead time while the Fault is active
0x6	WAIT	Stop all outputs, jump to the next compare cycle, and wait
0x7	WAITSW	Stop all outputs, wait for software action
0x8	EDGETRIG	Stop the output on the edge, jump to the next compare cycle
0x9	EDGETRIGFREQ	Stop the output on the edge, maintain the frequency
0xA	LVLTRIGFREQ	Stop the output at level, maintain the frequency

**23.5.13 Fault Control**

**Name:** FAULTCTRL  
**Offset:** 0x12  
**Reset:** 0x00  
**Property:** Configuration Change Protection

Bit	7	6	5	4	3	2	1	0
	CMPDxEN	CMPCxEN	CMPBxEN	CMPAxEN	CMPDx	CMPCx	CMPBx	CMPAx
Access	R/W	R/W	R/W	R/W	R/W	R/W	R/W	R/W
Reset	0	0	0	0	0	0	0	0

**Bits 4, 5, 6, 7 – CMPxEN** Compare x Enable  
 These bits enable the waveform from compare as output on the pin.

**Bits 0, 1, 2, 3 – CMPx** Compare x Value  
 These bits set the default state of the compare waveform output.

### 23.5.14 Delay Control

**Name:** DLYCTRL  
**Offset:** 0x14  
**Reset:** 0x00  
**Property:** -

	7	6	5	4	3	2	1	0
			DLYPRESC[1:0]		DLYTRIG[1:0]		DLYSEL[1:0]	
Access			R/W	R/W	R/W	R/W	R/W	R/W
Reset			0	0	0	0	0	0

#### Bits 5:4 – DLYPRESC[1:0] Delay Prescaler

These bits control the prescaler settings for the blanking or output event delay.

Value	Name	Description
0x0	DIV1	Prescaler division factor 1
0x1	DIV2	Prescaler division factor 2
0x2	DIV4	Prescaler division factor 4
0x3	DIV8	Prescaler division factor 8

#### Bits 3:2 – DLYTRIG[1:0] Delay Trigger

These bits control the trigger of the blanking or output event delay.

Value	Name	Description
0x0	CMPASET	CMPASET triggers delay
0x1	CMPACLR	CMPACLR triggers delay
0x2	CMPBSET	CMPBSET triggers delay
0x3	CMPBCLR	CMPASET triggers delay (end of cycle)

#### Bits 1:0 – DLYSEL[1:0] Delay Select

These bits control what function must be used by the delay trigger, the blanking or output event delay.

Value	Name	Description
0x0	OFF	Delay functionality not used
0x1	INBLANK	Input blanking enabled
0x2	EVENT	Event delay enabled
0x3	-	Reserved

**23.5.15 Delay Value**

**Name:** DLYVAL  
**Offset:** 0x15  
**Reset:** 0x00  
**Property:** -

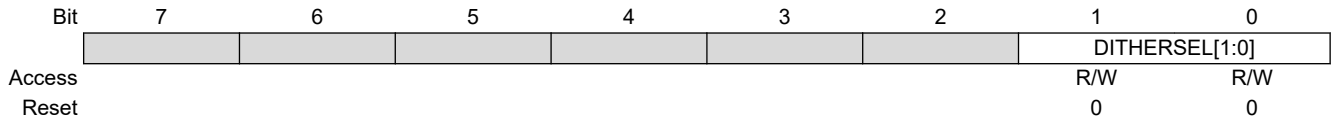
	7	6	5	4	3	2	1	0
	DLYVAL[7:0]							
Access	R/W	R/W	R/W	R/W	R/W	R/W	R/W	R/W
Reset	0	0	0	0	0	0	0	0

**Bits 7:0 – DLYVAL[7:0] Delay Value**

These bits configure the blanking/output event delay time or event output synchronization delay in a number of prescaled TCD cycles.

### 23.5.16 Dither Control

**Name:** DITCTRL  
**Offset:** 0x18  
**Reset:** 0x00  
**Property:** -



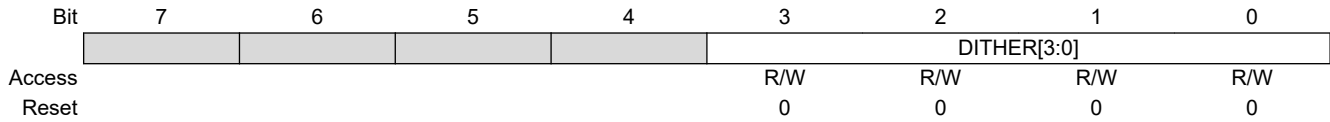
**Bits 1:0 – DITHERSEL[1:0]** Dither Select

This bit field selects which state of the TCD cycle will benefit from the dither function. See the [23.3.3.5 Dithering](#) section.

Value	Name	Description
0x0	ONTIMEB	On time ramp B
0x1	ONTIMEAB	On time ramp A and B
0x2	DEADTIMEB	Dead time ramp B
0x3	DEADTIMEAB	Dead time ramp A and B

**23.5.17 Dither Value**

**Name:** DITVAL  
**Offset:** 0x19  
**Reset:** 0x00  
**Property:** -

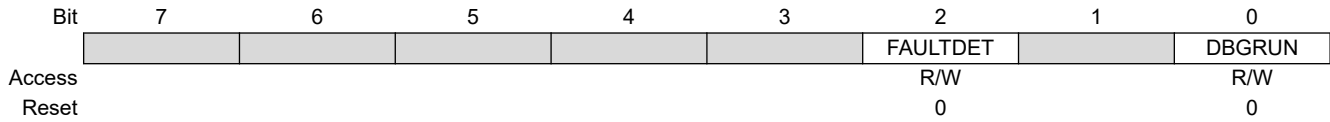


**Bits 3:0 – DITHER[3:0] Dither Value**

These bits configure the fractional adjustment of the on time or off time, according to the Dither Selection (DITHERSEL) bits in the Dither Control (TCDn.DITCTRL) register. The DITHER value is added to a 4-bit accumulator at the end of each TCD cycle. When the accumulator overflows, the frequency adjustment will occur. The DITHER bits are double-buffered, so the new value is copied when an update condition occurs.

**23.5.18 Debug Control**

**Name:** DBGCTRL  
**Offset:** 0x1E  
**Reset:** 0x00  
**Property:** -



**Bit 2 – FAULTDET** Fault Detection

This bit defines how the peripheral behaves when stopped in Debug mode.

Value	Name	Description
0	NONE	No Fault is generated if TCD is stopped in Debug mode
1	FAULT	A Fault is generated, and both trigger flags are set, if TCD is halted in Debug mode

**Bit 0 – DBGRUN** Debug Run

When written to '1', the peripheral will continue operating in Debug mode when the CPU is halted.

Value	Description
0	The peripheral is halted in Break Debug mode and ignores events
1	The peripheral will continue to run in Break Debug mode when the CPU is halted

### 23.5.19 Capture A

**Name:** CAPTUREA  
**Offset:** 0x22  
**Reset:** 0x00  
**Property:** -

The TCDn.CAPTUREAL and TCDn.CAPTUREAH register pair represents the 12-bit TCDn.CAPTUREA value.

For capture operation, these registers constitute the second buffer level and access point for the CPU. The TCDn.CAPTUREA registers are updated with the buffer value when an update condition occurs. The CAPTURE A register contains the TCD counter value when a trigger A or software capture A occurs.

The TCD counter value is synchronized to CAPTUREA by either software or an event.

The capture register is blocked for an update of new capture data until the higher byte of this register is read.

	15	14	13	12	11	10	9	8
	CAPTUREA[11:8]							
Access					R	R	R	R
Reset					0	0	0	0
	7	6	5	4	3	2	1	0
	CAPTUREA[7:0]							
Access	R	R	R	R	R	R	R	R
Reset	0	0	0	0	0	0	0	0

**Bits 11:0 – CAPTUREA[11:0]** Capture A Value



### 23.5.20 Capture B

**Name:** CAPTUREB  
**Offset:** 0x24  
**Reset:** 0x00  
**Property:** -

The TCDn.CAPTUREBL and TCDn.CAPTUREBH register pair represents the 12-bit TCDn.CAPTUREB value.

For capture operation, these registers constitute the second buffer level and access point for the CPU. The TCDn.CAPTUREB registers are updated with the buffer value when an update condition occurs. The CAPTURE B register contains the TCD counter value when a trigger B or software capture B occurs.

The TCD counter value is synchronized to CAPTUREB by either software or an event.

The capture register is blocked for an update of new capture data until the higher byte of this register is read.

	15	14	13	12	11	10	9	8
	CAPTUREB[11:8]							
Access					R	R	R	R
Reset					0	0	0	0
	7	6	5	4	3	2	1	0
	CAPTUREB[7:0]							
Access	R	R	R	R	R	R	R	R
Reset	0	0	0	0	0	0	0	0

**Bits 11:0 – CAPTUREB[11:0]** Capture B Value

**23.5.21 Compare Set A**

**Name:** CMPASET  
**Offset:** 0x28  
**Reset:** 0x00  
**Property:** -

The TCDn.CMPASETL and TCDn.CMPASETH register pair represents the 12-bit TCDn.CMPASET value. This register is continuously compared to the counter value. Then, the outputs from the comparators are used for generating waveforms.

Bit	15	14	13	12	11	10	9	8
	CMPASET[11:8]							
Access					R/W	R/W	R/W	R/W
Reset					0	0	0	0
Bit	7	6	5	4	3	2	1	0
	CMPASET[7:0]							
Access	R/W	R/W	R/W	R/W	R/W	R/W	R/W	R/W
Reset	0	0	0	0	0	0	0	0

**Bits 11:0 – CMPASET[11:0]** Compare A Set  
 These bits hold the value of the compare register.

**23.5.22 Compare Set B**

**Name:** CMPBSET  
**Offset:** 0x2C  
**Reset:** 0x00  
**Property:** -

The TCDn.CMPBSETL and TCDn.CMPBSETH register pair represents the 12-bit TCDn.CMPBSET value. This register is continuously compared to the counter value. Then, the outputs from the comparators are used for generating waveforms.

Bit	15	14	13	12	11	10	9	8
	CMPBSET[11:8]							
Access					R/W	R/W	R/W	R/W
Reset					0	0	0	0
Bit	7	6	5	4	3	2	1	0
	CMPBSET[7:0]							
Access	R/W	R/W	R/W	R/W	R/W	R/W	R/W	R/W
Reset	0	0	0	0	0	0	0	0

**Bits 11:0 – CMPBSET[11:0]** Compare B Set  
 These bits hold the value of the compare register.

**23.5.23 Compare Clear A**

**Name:** CMPACLR  
**Offset:** 0x2A  
**Reset:** 0x00  
**Property:** -

The TCDn.CMPACLRH and TCDn.CMPACLRH register pair represents the 12-bit TCDn.CMPACLR value. This register is continuously compared to the counter value. Then, the outputs from the comparators are used for generating waveforms.

Bit	15	14	13	12	11	10	9	8
	CMPACLR[11:8]							
Access					R/W	R/W	R/W	R/W
Reset					0	0	0	0
Bit	7	6	5	4	3	2	1	0
	CMPACLR[7:0]							
Access	R/W	R/W	R/W	R/W	R/W	R/W	R/W	R/W
Reset	0	0	0	0	0	0	0	0

**Bits 11:0 – CMPACLR[11:0]** Compare A Clear  
 These bits hold the value of the compare register.

**23.5.24 Compare Clear B**

**Name:** CMPBCLR  
**Offset:** 0x2E  
**Reset:** 0x00  
**Property:** -

The TCDn.CMPBCLRL and TCDn.CMPBCLRH register pair represents the 12-bit TCDn.CMPBCLR value. This register is continuously compared to the counter value. Then, the outputs from the comparators are used for generating waveforms.

Bit	15	14	13	12	11	10	9	8
	CMPBCLR[11:8]							
Access					R/W	R/W	R/W	R/W
Reset					0	0	0	0
Bit	7	6	5	4	3	2	1	0
	CMPBCLR[7:0]							
Access	R/W	R/W	R/W	R/W	R/W	R/W	R/W	R/W
Reset	0	0	0	0	0	0	0	0

**Bits 11:0 – CMPBCLR[11:0]** Compare B Clear  
 These bits hold the value of the compare register.

## 24. RTC - Real-Time Counter

### 24.1 Features

- 16-bit Resolution
- Selectable Clock Sources
- Programmable 15-bit Clock Prescaling
- One Compare Register
- One Period Register
- Clear Timer on Period Overflow
- Optional Interrupt/Event on Overflow and Compare Match
- Periodic Interrupt and Event
- Crystal Error Correction

### 24.2 Overview

The RTC peripheral offers two timing functions: the Real-Time Counter (RTC) and a Periodic Interrupt Timer (PIT).

The PIT functionality can be enabled independently of the RTC functionality.

#### RTC - Real-Time Counter

The RTC counts (prescaled) clock cycles in a Counter register and compares the content of the Counter register to a Period register and a Compare register.

The RTC can generate both interrupts and events on compare match or overflow. It will generate a compare interrupt and/or event at the first count after the counter equals the Compare register value, and an overflow interrupt and/or event at the first count after the counter value equals the Period register value. The overflow will reset the counter value to zero.

The RTC peripheral typically runs continuously, including in Low-Power sleep modes, to keep track of time. It can wake up the device from sleep modes and/or interrupt the device at regular intervals.

The reference clock is typically the 32.768 kHz output from an external crystal. The RTC can also be clocked from an external clock signal, the 32.768 kHz Internal Oscillator (OSC32K), or the OSC32K divided by 32.

The RTC peripheral includes a 15-bit programmable prescaler that can scale down the reference clock before it reaches the counter. A wide range of resolutions and time-out periods can be configured for the RTC. With a 32.768 kHz clock source, the maximum resolution is 30.5  $\mu$ s, and time-out periods can be up to two seconds. With a resolution of 1s, the maximum time-out period is more than 18 hours (65536 seconds).

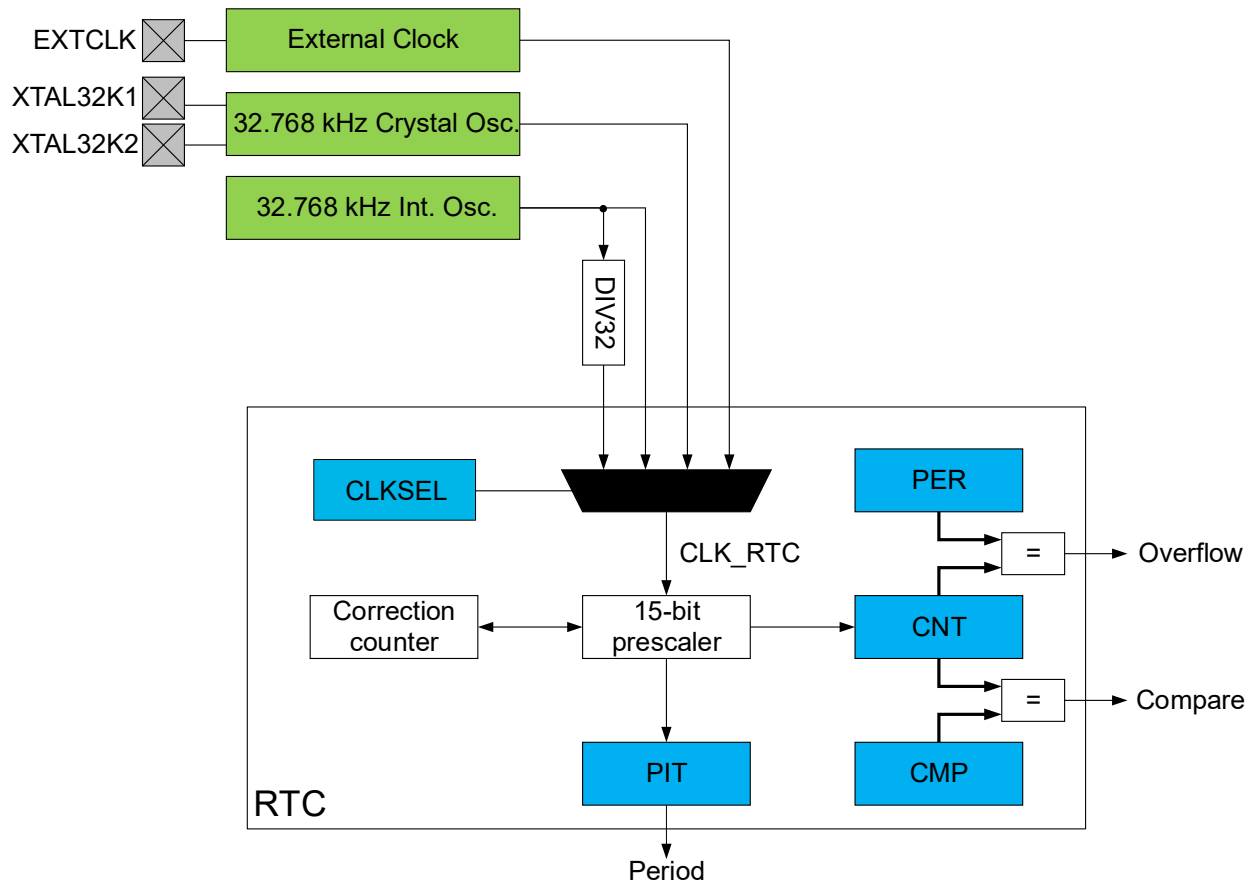
The RTC also supports crystal error correction when operated using external crystal selection. An externally calibrated value will be used for correction. The RTC can be adjusted by software with an accuracy of  $\pm 1$  PPM, and the maximum adjustment is  $\pm 127$  PPM. The RTC correction operation will either speed up (by skipping count) or slow down (by adding extra count) the prescaler to account for the crystal error.

#### PIT - Periodic Interrupt Timer

The PIT uses the same clock source (CLK\_RTC) as the RTC function and can generate an interrupt request or a level event on every  $n^{\text{th}}$  clock period. The  $n$  can be selected from {4, 8, 16,... 32768} for interrupts and from {64, 128, 256,... 8192} for events.

## 24.2.1 Block Diagram

Figure 24-1. Block Diagram



## 24.3 Clocks

The peripheral clock (CLK\_PER) is required to be at least four times faster than the RTC clock (CLK\_RTC) for reading the counter value, regardless of the prescaler setting.

A 32.768 kHz crystal can be connected to the XTAL32K1 or XTAL32K2 pins, along with any required load capacitors. Alternatively, an external digital clock can be connected to the XTAL32K1 pin.

## 24.4 RTC Functional Description

The RTC peripheral offers two timing functions: the Real-Time Counter (RTC) and a Periodic Interrupt Timer (PIT). This subsection describes the RTC.

### 24.4.1 Initialization

Before enabling the RTC peripheral and the desired actions (interrupt requests and output events), the source clock for the RTC counter must be configured to operate the RTC.

#### 24.4.1.1 Configure the Clock CLK\_RTC

To configure the CLK\_RTC, follow these steps:

1. Configure the desired oscillator to operate as required, in the Clock Controller (CLKCTRL) peripheral.
2. Write the Clock Select (CLKSEL) bit field in the Clock Selection (RTC.CLKSEL) register accordingly.

---

The CLK\_RTC clock configuration is used by both RTC and PIT functionality.

#### 24.4.1.2 Configure RTC

To operate the RTC, follow these steps:

1. Set the compare value in the Compare (RTC.CMP) register, and/or the overflow value in the Period (RTC.PER) register.
2. Enable the desired interrupts by writing to the respective interrupt enable bits (CMP, OVF) in the Interrupt Control (RTC.INTCTRL) register.
3. Configure the RTC internal prescaler by writing the desired value to the Prescaler (PRESCALER) bit field in the Control A (RTC.CTRLA) register.
4. Enable the RTC by writing a '1' to the RTC Peripheral Enable (RTCEM) bit in the RTC.CTRLA register.

**Note:** The RTC peripheral is used internally during device start-up. Always check the Synchronization Busy bits in the Status (RTC.STATUS) and Periodic Interrupt Timer Status (RTC.PITSTATUS) registers, and on the initial configuration.

### 24.4.2 Operation - RTC

#### 24.4.2.1 Enabling and Disabling

The RTC is enabled by writing the RTC Peripheral Enable (RTCEM) bit in the Control A (RTC.CTRLA) register to '1'. The RTC is disabled by writing the RTC Peripheral Enable (RTCEM) bit in RTC.CTRLA to '0'.

## 24.5 PIT Functional Description

The RTC peripheral offers two timing functions: the Real-Time Counter (RTC) and a Periodic Interrupt Timer (PIT). This subsection describes the PIT.

#### 24.5.1 Initialization

To operate the PIT, follow these steps:

1. Configure the RTC clock CLK\_RTC as described in section [24.4.1.1 Configure the Clock CLK\\_RTC](#).
2. Enable the interrupt by writing a '1' to the Periodic Interrupt (PI) bit in the PIT Interrupt Control (RTC.PITINTCTRL) register.
3. Select the period for the interrupt by writing the desired value to the Period (PERIOD) bit field in the Periodic Interrupt Timer Control A (RTC.PITCTRLA) register.
4. Enable the PIT by writing a '1' to the Periodic Interrupt Timer Enable (PITEN) bit in the RTC.PITCTRLA register.

**Note:** The RTC peripheral is used internally during device start-up. Always check the Synchronization Busy bits in the RTC.STATUS and RTC.PITSTATUS registers, and on the initial configuration.

#### 24.5.2 Operation - PIT

##### 24.5.2.1 Enabling and Disabling

The PIT is enabled by writing the Periodic Interrupt Timer Enable (PITEN) bit in the Periodic Interrupt Timer Control A (RTC.PITCTRLA) register to '1'. The PIT is disabled by writing the Periodic Interrupt Timer Enable (PITEN) bit in RTC.PITCTRLA to '0'.

##### 24.5.2.2 PIT Interrupt Timing

###### Timing of the First Interrupt

The PIT function and the RTC function are running from the same counter inside the prescaler and can be configured as described below:

- The RTC interrupt period is configured by writing the Period (RTC.PER) register
- The PIT interrupt period is configured by writing the Period (PERIOD) bit field in Periodic Interrupt Timer Control A (RTC.PITCTRLA) register



The prescaler is OFF when both functions are OFF (RTC Peripheral Enable (RTCEN) bit in RTC.CTRLA and the Periodic Interrupt Timer Enable (PITEN) bit in RTC.PITCTRLA are '0'), but it is running (that is, its internal counter is counting) when either function is enabled. For this reason, the timing of the first PIT interrupt and the first RTC count tick will be unknown (anytime between enabling and a full period).

### Continuous Operation

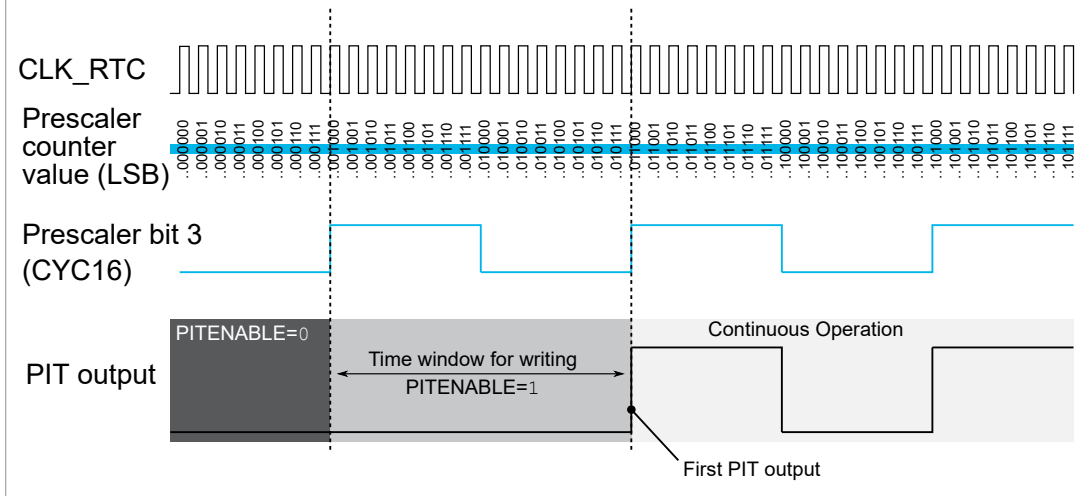
After the first interrupt, the PIT will continue toggling every  $\frac{1}{2}$  PIT period resulting in a full PIT period signal.

#### Example 24-1. PIT Timing Diagram for PERIOD=CYC16

For PERIOD=CYC16 in RTC.PITCTRLA, the PIT output effectively follows the state of the prescaler counter bit 3, so the resulting interrupt output has a period of 16 CLK\_RTC cycles.

The time between writing PITEN to '1' and the first PIT interrupt can vary between virtually zero and a full PIT period of 16 CLK\_RTC cycles. The precise delay between enabling the PIT and its first output depends on the prescaler's counting phase: the first interrupt shown below is produced by writing PITEN to '1' at any time inside the leading time window.

Figure 24-2. Timing Between PIT Enable and First Interrupt



## 24.6 Crystal Error Correction

The prescaler for the RTC and PIT can do internal frequency correction of the crystal clock by using the PPM error value from the Crystal Frequency Calibration (CALIB) register when the Frequency Correction Enable (CORREN) bit in the RTC.CTRLA register is '1'.

The CALIB register must be written by the user, based on the information about the frequency error. The correction operation is performed by adding or removing a number of cycles equal to the value given in the Error Correction Value (ERROR) bit field in the CALIB register spread throughout a million-cycle interval.

The correction of the clock will be reflected in the RTC count value available through the Count (RTC.CNT) registers or in the PIT intervals.

If disabling the correction feature, an ongoing correction cycle will be completed before the function is disabled.

**Note:** If using this feature with a negative correction, the minimum prescaler configuration is DIV2.

## 24.7 Events

The RTC can generate the events described in the following table:

**Table 24-1. RTC Event Generators**

Generator Name		Description	Event Type	Clock Domain	Length of the Event
Module	Event				
RTC	OVF	Overflow	Pulse	CLK_RTC	One CLK_RTC period
	CMP	Compare Match			One CLK_RTC period
	PIT_DIV8192	Prescaled RTC clock divided by 8192	Level		Given by prescaled RTC clock divided by 8192
	PIT_DIV4096	Prescaled RTC clock divided by 4096			Given by prescaled RTC clock divided by 4096
	PIT_DIV2048	Prescaled RTC clock divided by 2048			Given by prescaled RTC clock divided by 2048
	PIT_DIV1024	Prescaled RTC clock divided by 1024			Given by prescaled RTC clock divided by 1024
	PIT_DIV512	Prescaled RTC clock divided by 512			Given by prescaled RTC clock divided by 512
	PIT_DIV256	Prescaled RTC clock divided by 256			Given by prescaled RTC clock divided by 256
	PIT_DIV128	Prescaled RTC clock divided by 128			Given by prescaled RTC clock divided by 128
	PIT_DIV64	Prescaled RTC clock divided by 64			Given by prescaled RTC clock divided by 64

The conditions for generating the OVF and CMP events are identical to those that will raise the corresponding interrupt flags in the RTC.INTFLAGS register.

Refer to the (*EVSYS*) *Event System* section for more details regarding event users and Event System configuration.

## 24.8 Interrupts

**Table 24-2. Available Interrupt Vectors and Sources**

Name	Vector Description	Conditions
RTC	Real-Time Counter overflow and compare match interrupt	<ul style="list-style-type: none"> <li>• Overflow (OVF): The counter has reached the value from the RTC.PER register and wrapped to zero</li> <li>• Compare (CMP): Match between the value from the Counter (RTC.CNT) register and the value from the Compare (RTC.CMP) register</li> </ul>
PIT	Periodic Interrupt Timer interrupt	A time period has passed, as configured by the PERIOD bit field in RTC.PITCTRLA

When an interrupt condition occurs, the corresponding interrupt flag is set in the peripheral's Interrupt Flags (*peripheral*.INTFLAGS) register.

An interrupt source is enabled or disabled by writing to the corresponding enable bit in the peripheral's Interrupt Control (*peripheral*.INTCTRL) register.

An interrupt request is generated when the corresponding interrupt source is enabled, and the interrupt flag is set. The interrupt request remains active until the interrupt flag is cleared. See the peripheral's INTFLAGS register for details on how to clear interrupt flags.

Note that:

- The RTC has two INTFLAGS registers: RTC.INTFLAGS and RTC.PITINTFLAGS.
- The RTC has two INTCTRL registers: RTC.INTCTRL and RTC.PITINTCTRL.

## 24.9 Sleep Mode Operation

The RTC will continue to operate in Idle sleep mode. It will run in Standby sleep mode if the Run in Standby (RUNSTDBY) bit in RTC.CTRLA is set.

The PIT will continue to operate in any sleep mode.

## 24.10 Synchronization

Both the RTC and the PIT are asynchronous, operating from a different clock source (CLK\_RTC) independently of the peripheral clock (CLK\_PER). For Control and Count register updates, it will take some RTC and/or peripheral clock cycles before an updated register value is available in a register or until a configuration change affects the RTC or PIT, respectively. This synchronization time is described for each register in the *Register Description* section.

For some RTC registers, a Synchronization Busy flag is available (CMPBUSY, PERBUSY, CNTBUSY, CTRLABUSY) in the Status (RTC.STATUS) register.

For the RTC.PITCTRLA register, a Synchronization Busy flag is available (CTRLBUSY) in the Periodic Interrupt Timer Status (RTC.PITSTATUS) register.

Check these flags before writing to the mentioned registers.

## 24.11 Debug Operation

If the Debug Run (DBGRUN) bit in the Debug Control (RTC.DBGCTRL) register is '1', the RTC will continue normal operation. If DBGRUN is '0' and the CPU is halted, the RTC will halt the operation and ignore any incoming events.

If the Debug Run (DBGRUN) bit in the Periodic Interrupt Timer Debug Control (RTC.PITDBGCTRL) register is '1', the PIT will continue normal operation. If DBGRUN is '0' in the Debug mode and the CPU is halted, the PIT output will be low. When the PIT output is high at the time, a new positive edge occurs to set the interrupt flag when restarting from a break. The result is an additional PIT interrupt that would not happen during normal operation. If the PIT output is low at the break, the PIT will resume low without additional interrupt.

## 24.12 Register Summary

Offset	Name	Bit Pos.	7	6	5	4	3	2	1	0
0x00	<a href="#">CTRLA</a>	7:0	RUNSTDBY	PRESCALER[3:0]				CORREN		RTCEN
0x01	<a href="#">STATUS</a>	7:0					CMPBUSY	PERBUSY	CNTBUSY	CTRLABUSY
0x02	<a href="#">INTCTRL</a>	7:0							CMP	OVF
0x03	<a href="#">INTFLAGS</a>	7:0							CMP	OVF
0x04	<a href="#">TEMP</a>	7:0	TEMP[7:0]							
0x05	<a href="#">DBGCTRL</a>	7:0								DBGRUN
0x06	<a href="#">CALIB</a>	7:0	SIGN	ERROR[6:0]						
0x07	<a href="#">CLKSEL</a>	7:0							CLKSEL[1:0]	
0x08	<a href="#">CNT</a>	7:0	CNT[7:0]							
		15:8	CNT[15:8]							
0x0A	<a href="#">PER</a>	7:0	PER[7:0]							
		15:8	PER[15:8]							
0x0C	<a href="#">CMP</a>	7:0	CMP[7:0]							
		15:8	CMP[15:8]							
0x0E ... 0x0F	Reserved									
0x10	<a href="#">PITCTRLA</a>	7:0		PERIOD[3:0]						PITEN
0x11	<a href="#">PITSTATUS</a>	7:0								CTRLBUSY
0x12	<a href="#">PITINTCTRL</a>	7:0								PI
0x13	<a href="#">PITINTFLAGS</a>	7:0								PI
0x14	Reserved									
0x15	<a href="#">PITDBGCTRL</a>	7:0								DBGRUN

## 24.13 Register Description

## 24.13.1 Control A

**Name:** CTRLA  
**Offset:** 0x00  
**Reset:** 0x00  
**Property:** -

Bit	7	6	5	4	3	2	1	0
	RUNSTDBY	PRESCALER[3:0]				CORREN		RTCEN
Access	R/W	R/W	R/W	R/W	R/W	R/W		R/W
Reset	0	0	0	0	0	0		0

**Bit 7 – RUNSTDBY** Run in Standby

Value	Description
0	RTC disabled in Standby sleep mode
1	RTC enabled in Standby sleep mode

**Bits 6:3 – PRESCALER[3:0]** Prescaler

These bits define the prescaling of the CLK\_RTC clock signal. Due to synchronization between the RTC clock and the peripheral clock, there is a latency of two RTC clock cycles from updating the register until this has an effect. Application software needs to check that the CTRLABUSY flag in RTC.STATUS register is cleared before writing to this register.

Value	Name	Description
0x0	DIV1	RTC clock/1 (no prescaling)
0x1	DIV2	RTC clock/2
0x2	DIV4	RTC clock/4
0x3	DIV8	RTC clock/8
0x4	DIV16	RTC clock/16
0x5	DIV32	RTC clock/32
0x6	DIV64	RTC clock/64
0x7	DIV128	RTC clock/128
0x8	DIV256	RTC clock/256
0x9	DIV512	RTC clock/512
0xA	DIV1024	RTC clock/1024
0xB	DIV2048	RTC clock/2048
0xC	DIV4096	RTC clock/4096
0xD	DIV8192	RTC clock/8192
0xE	DIV16384	RTC clock/16384
0xF	DIV32768	RTC clock/32768

**Bit 2 – CORREN** Frequency Correction Enable

Value	Description
0	Frequency correction is disabled
1	Frequency correction is enabled

**Bit 0 – RTCEN** RTC Peripheral Enable

Value	Description
0	RTC peripheral is disabled
1	RTC peripheral is enabled

**24.13.2 Status**

**Name:** STATUS  
**Offset:** 0x01  
**Reset:** 0x00  
**Property:** -

Bit	7	6	5	4	3	2	1	0
					CMPBUSY	PERBUSY	CNTBUSY	CTRLABUSY
Access					R	R	R	R
Reset					0	0	0	0

**Bit 3 – CMPBUSY** Compare Synchronization Busy

This bit is '1' when the RTC is busy synchronizing the Compare (RTC.CMP) register in the RTC clock domain.

**Bit 2 – PERBUSY** Period Synchronization Busy

This bit is '1' when the RTC is busy synchronizing the Period (RTC.PER) register in the RTC clock domain.

**Bit 1 – CNTBUSY** Counter Synchronization Busy

This bit is '1' when the RTC is busy synchronizing the Count (RTC.CNT) register in the RTC clock domain.

**Bit 0 – CTRLABUSY** Control A Synchronization Busy

This bit is '1' when the RTC is busy synchronizing the Control A (RTC.CTRLA) register in the RTC clock domain.

## 24.13.3 Interrupt Control

**Name:** INTCTRL  
**Offset:** 0x02  
**Reset:** 0x00  
**Property:** -

Bit	7	6	5	4	3	2	1	0
							CMP	OVF
Access							R/W	R/W
Reset							0	0

**Bit 1 – CMP** Compare Match Interrupt Enable

Enable interrupt-on-compare match (that is, when the value from the Count (RTC.CNT) register matches the value from the Compare (RTC.CMP) register).

Value	Description
0	The compare match interrupt is disabled
1	The compare match interrupt is enabled

**Bit 0 – OVF** Overflow Interrupt Enable

Enable interrupt-on-counter overflow (that is, when the value from the Count (RTC.CNT) register matched the value from the Period (RTC.PER) register and wraps around to zero).

Value	Description
0	The overflow interrupt is disabled
1	The overflow interrupt is enabled

**24.13.4 Interrupt Flag**

**Name:** INTFLAGS  
**Offset:** 0x03  
**Reset:** 0x00  
**Property:** -

Bit	7	6	5	4	3	2	1	0
							CMP	OVF
Access							R/W	R/W
Reset							0	0

**Bit 1 – CMP** Compare Match Interrupt Flag

This flag is set when the value from the Count (RTC.CNT) register matches the value from the Compare (RTC.CMP) register.

Writing a '1' to this bit clears the flag.

**Bit 0 – OVF** Overflow Interrupt Flag

This flag is set when the value from the Count (RTC.CNT) register has reached the value from the Period (RTC.PER) register and wrapped to zero.

Writing a '1' to this bit clears the flag.



### 24.13.5 Temporary

**Name:** TEMP  
**Offset:** 0x4  
**Reset:** 0x00  
**Property:** -

The Temporary register is used by the CPU for 16-bit single-cycle access to the 16-bit registers of this peripheral. The register is common for all the 16-bit registers of this peripheral and can be read and written by software. For more details on reading and writing 16-bit registers, refer to *Accessing 16-Bit Registers* in the *Memories* section.

Bit	7	6	5	4	3	2	1	0
	TEMP[7:0]							
Access	R/W	R/W	R/W	R/W	R/W	R/W	R/W	R/W
Reset	0	0	0	0	0	0	0	0

#### Bits 7:0 – TEMP[7:0] Temporary

Temporary register for read/write operations in 16-bit registers.

**24.13.6 Debug Control**

**Name:** DBGCTRL  
**Offset:** 0x05  
**Reset:** 0x00  
**Property:** -

Bit	7	6	5	4	3	2	1	0
								DBGRUN
Access								R/W
Reset								0

**Bit 0 – DBGRUN** Debug Run

Value	Description
0	The peripheral is halted in Break Debug mode and ignores events
1	The peripheral will continue to run in Break Debug mode when the CPU is halted

**24.13.7 Crystal Frequency Calibration**

**Name:** CALIB  
**Offset:** 0x06  
**Reset:** 0x00  
**Property:** -

This register stores the error value and the type of correction to be done. This register is written by software with an error value based on external calibration and/or temperature correction/s.

Bit	7	6	5	4	3	2	1	0
	SIGN	ERROR[6:0]						
Access	R/W	R/W	R/W	R/W	R/W	R/W	R/W	R/W
Reset	0	0	0	0	0	0	0	0

**Bit 7 – SIGN** Error Correction Sign Bit

This bit shows the direction of the correction.

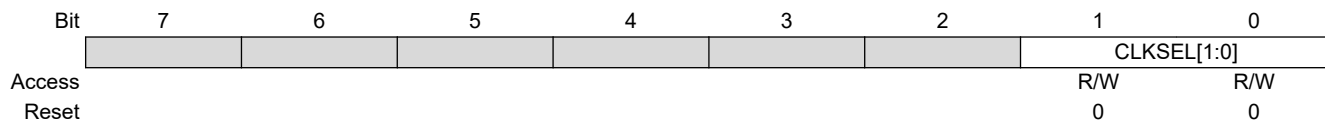
Value	Description
0x0	Positive correction causing the prescaler to count slower
0x1	Negative correction causing the prescaler to count faster. This requires that the minimum prescaler configuration is DIV2

**Bits 6:0 – ERROR[6:0]** Error Correction Value

The number of correction clocks for each million RTC clock cycles interval (PPM).

### 24.13.8 Clock Selection

**Name:** CLKSEL  
**Offset:** 0x07  
**Reset:** 0x00  
**Property:** -



#### Bits 1:0 – CLKSEL[1:0] Clock Select

Writing these bits select the source for the RTC clock (CLK\_RTC).

Value	Name	Description
0x00	OSC32K	32.768 kHz from OSC32K
0x01	OSC1K	1.024 kHz from OSC32K
0x02	XTAL32K	32.768 kHz from XOSC32K or external clock from XTAL32K1 pin
0x03	EXTCLK	External clock from the EXTCLK pin

**24.13.9 Count**

**Name:** CNT  
**Offset:** 0x08  
**Reset:** 0x0000  
**Property:** -

The RTC.CNTL and RTC.CNTH register pair represents the 16-bit value, RTC.CNT. The low byte [7:0] (suffix L) is accessible at the original offset. The high byte [15:8] (suffix H) can be accessed at offset + 0x01.

Due to the synchronization between the RTC clock and main clock domains, there is a latency of two RTC clock cycles from updating the register until this has an effect. The application software needs to check that the CNTBUSY flag in RTC.STATUS is cleared before writing to this register.

Bit	15	14	13	12	11	10	9	8
	CNT[15:8]							
Access	R/W	R/W	R/W	R/W	R/W	R/W	R/W	R/W
Reset	0	0	0	0	0	0	0	0
Bit	7	6	5	4	3	2	1	0
	CNT[7:0]							
Access	R/W	R/W	R/W	R/W	R/W	R/W	R/W	R/W
Reset	0	0	0	0	0	0	0	0

**Bits 15:8 – CNT[15:8] Counter High Byte**

These bits hold the MSB of the 16-bit Counter register.

**Bits 7:0 – CNT[7:0] Counter Low Byte**

These bits hold the LSB of the 16-bit Counter register.

**24.13.10 Period**

**Name:** PER  
**Offset:** 0x0A  
**Reset:** 0xFFFF  
**Property:** -

The RTC.PERL and RTC.PERH register pair represents the 16-bit value, RTC.PER. The low byte [7:0] (suffix L) is accessible at the original offset. The high byte [15:8] (suffix H) can be accessed at offset + 0x01.

Due to the synchronization between the RTC clock and main clock domains, there is a latency of two RTC clock cycles from updating the register until this has an effect. The application software needs to check that the PERBUSY flag in RTC.STATUS is cleared before writing to this register.

Bit	15	14	13	12	11	10	9	8
	PER[15:8]							
Access	R/W	R/W	R/W	R/W	R/W	R/W	R/W	R/W
Reset	1	1	1	1	1	1	1	1
Bit	7	6	5	4	3	2	1	0
	PER[7:0]							
Access	R/W	R/W	R/W	R/W	R/W	R/W	R/W	R/W
Reset	1	1	1	1	1	1	1	1

**Bits 15:8 – PER[15:8]** Period High Byte

These bits hold the MSB of the 16-bit Period register.

**Bits 7:0 – PER[7:0]** Period Low Byte

These bits hold the LSB of the 16-bit Period register.

### 24.13.11 Compare

**Name:** CMP  
**Offset:** 0x0C  
**Reset:** 0x0000  
**Property:** -

The RTC.CMPL and RTC.CMPH register pair represents the 16-bit value, RTC.CMP. The low byte [7:0] (suffix L) is accessible at the original offset. The high byte [15:8] (suffix H) can be accessed at offset + 0x01.

Bit	15	14	13	12	11	10	9	8
	CMP[15:8]							
Access	R/W	R/W	R/W	R/W	R/W	R/W	R/W	R/W
Reset	0	0	0	0	0	0	0	0
Bit	7	6	5	4	3	2	1	0
	CMP[7:0]							
Access	R/W	R/W	R/W	R/W	R/W	R/W	R/W	R/W
Reset	0	0	0	0	0	0	0	0

**Bits 15:8 – CMP[15:8]** Compare High Byte  
 These bits hold the MSB of the 16-bit Compare register.

**Bits 7:0 – CMP[7:0]** Compare Low Byte  
 These bits hold the LSB of the 16-bit Compare register.

## 24.13.12 Periodic Interrupt Timer Control A

**Name:** PITCTRLA  
**Offset:** 0x10  
**Reset:** 0x00  
**Property:** -

Bit	7	6	5	4	3	2	1	0
	PERIOD[3:0]							PITEN
Access		R/W	R/W	R/W	R/W			R/W
Reset		0	0	0	0			0

**Bits 6:3 – PERIOD[3:0]** Period

Writing this bit field selects the number of RTC clock cycles between each interrupt.

Value	Name	Description
0x0	OFF	No interrupt
0x1	CYC4	4 cycles
0x2	CYC8	8 cycles
0x3	CYC16	16 cycles
0x4	CYC32	32 cycles
0x5	CYC64	64 cycles
0x6	CYC128	128 cycles
0x7	CYC256	256 cycles
0x8	CYC512	512 cycles
0x9	CYC1024	1024 cycles
0xA	CYC2048	2048 cycles
0xB	CYC4096	4096 cycles
0xC	CYC8192	8192 cycles
0xD	CYC16384	16384 cycles
0xE	CYC32768	32768 cycles
0xF	-	Reserved

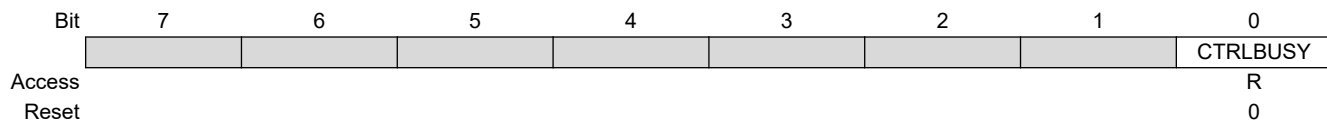
**Bit 0 – PITEN** Periodic Interrupt Timer Enable

Value	Description
0	Periodic Interrupt Timer disabled
1	Periodic Interrupt Timer enabled



### 24.13.13 Periodic Interrupt Timer Status

**Name:** PITSTATUS  
**Offset:** 0x11  
**Reset:** 0x00  
**Property:** -

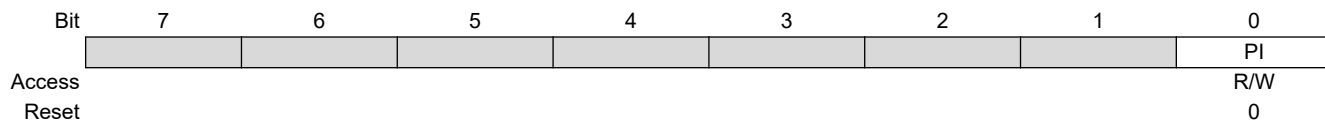


**Bit 0 – CTRLBUSY** PITCTRLA Synchronization Busy

This bit is '1' when the RTC is busy synchronizing the Periodic Interrupt Timer Control A (RTC.PITCTRLA) register in the RTC clock domain.

### 24.13.14 PIT Interrupt Control

**Name:** PITINTCTRL  
**Offset:** 0x12  
**Reset:** 0x00  
**Property:** -

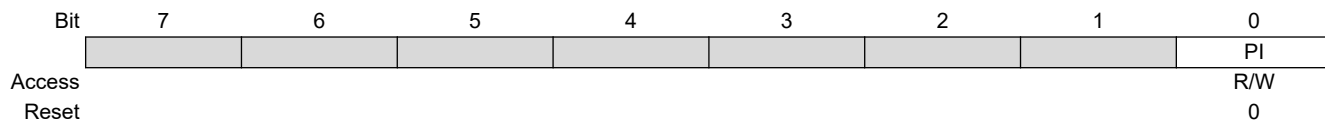


#### Bit 0 – PI Periodic Interrupt

Value	Description
0	The periodic interrupt is disabled
1	The periodic interrupt is enabled

### 24.13.15 PIT Interrupt Flag

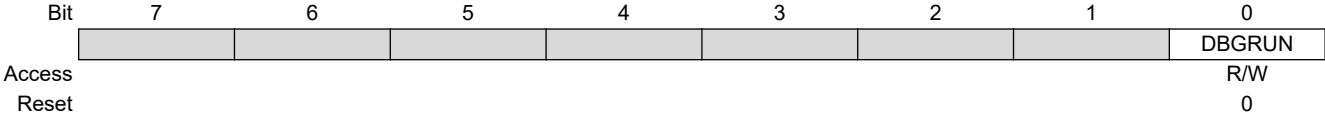
**Name:** PITINTFLAGS  
**Offset:** 0x13  
**Reset:** 0x00  
**Property:** -



**Bit 0 – PI** Periodic Interrupt Flag  
 This flag is set when a periodic interrupt is issued.  
 Writing a '1' clears the flag.

**24.13.16 Periodic Interrupt Timer Debug Control**

**Name:** PITDBGCTRL  
**Offset:** 0x15  
**Reset:** 0x00  
**Property:** -



**Bit 0 – DBGRUN** Debug Run

Value	Description
0	The peripheral is halted in Break Debug mode and ignores events
1	The peripheral will continue to run in Break Debug mode when the CPU is halted

## 25. USART - Universal Synchronous and Asynchronous Receiver and Transmitter

### 25.1 Features

- Full-Duplex Operation
- Half-Duplex Operation:
  - One-Wire mode
  - RS-485 mode
- Asynchronous or Synchronous Operation
- Supports Serial Frames with Five, Six, Seven, Eight or Nine Data Bits and One or Two Stop Bits
- Fractional Baud Rate Generator:
  - Can generate the desired baud rate from any peripheral clock frequency
  - No need for an external oscillator
- Built-In Error Detection and Correction Schemes:
  - Odd or even parity generation and parity check
  - Buffer overflow and frame error detection
  - Noise filtering including false Start bit detection and digital low-pass filter
- Separate Interrupts for:
  - Transmit complete
  - Transmit Data register empty
  - Receive complete
- Master SPI Mode
- Multiprocessor Communication Mode
- Start-of-Frame Detection
- IRCOM Module for IrDA® Compliant Pulse Modulation/Demodulation
- LIN Slave Support

### 25.2 Overview

The Universal Synchronous and Asynchronous serial Receiver and Transmitter (USART) is a fast and flexible serial communication peripheral. The USART supports a number of different modes of operation that can accommodate multiple types of applications and communication devices. For example, the One-Wire Half-Duplex mode is useful when low pin count applications are desired. The communication is frame-based, and the frame format can be customized to support a wide range of standards.

The USART is buffered in both directions, enabling continued data transmission without any delay between frames. Separate interrupts for receive and transmit completion allow fully interrupt-driven communication.

The transmitter consists of a single-write buffer, a Shift register, and control logic for different frame formats. The receiver consists of a two-level receive buffer and a Shift register. The status information of the received data is available for error checking. Data and clock recovery units ensure robust synchronization and noise filtering during asynchronous data reception.

25.2.1 Block Diagram

Figure 25-1. USART Block Diagram



25.2.2 Signal Description

Signal	Type	Description
XCK	Output/input	Clock for synchronous operation
XDIR	Output	Transmit enable for RS-485
TxD	Output/input	Transmitting line (and receiving line in One-Wire mode)
RxD	Input	Receiving line

25.3 Functional Description

25.3.1 Initialization

Full Duplex Mode:

1. Set the baud rate (USARTn.BAUD).
2. Set the frame format and mode of operation (USARTn.CTRLA).
3. Configure the TXD pin as an output.
4. Enable the transmitter and the receiver (USARTn.CTRLB).

Notes:

- For interrupt-driven USART operation, global interrupts must be disabled during the initialization
- Before doing a reinitialization with a changed baud rate or frame format, be sure that there are no ongoing transmissions while the registers are changed

One-Wire Half Duplex Mode:

1. Internally connect the TXD to the USART receiver (the LBME bit in the USARTn.CTRLA register).
2. Enable internal pull-up for the RX/TX pin (the PULLUPEN bit in the PORTx.PINnCTRL register).

3. Enable Open-Drain mode (the ODME bit in the USARTn.CTRLB register).
4. Set the baud rate (USARTn.BAUD).
5. Set the frame format and mode of operation (USARTn.CTRLA).
6. Enable the transmitter and the receiver (USARTn.CTRLB).

**Notes:**

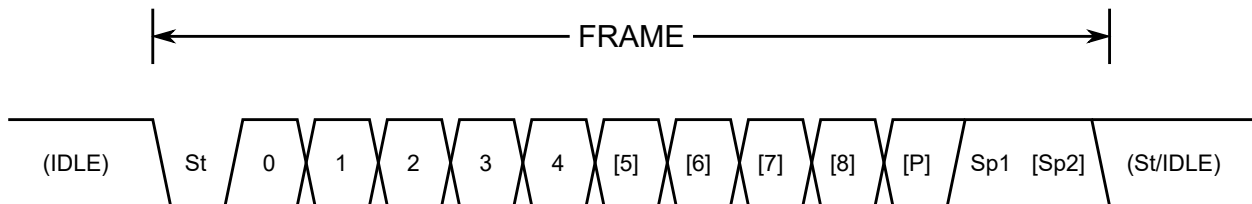
- When Open-Drain mode is enabled, the TXD pin is automatically set to output by hardware
- For interrupt-driven USART operation, global interrupts must be disabled during the initialization
- Before doing a reinitialization with a changed baud rate or frame format, be sure that there are no ongoing transmissions while the registers are changed

**25.3.2 Operation****25.3.2.1 Frame Formats**

The USART data transfer is frame-based. A frame starts with a Start bit followed by one character of data bits. If enabled, the Parity bit is inserted after the data bits and before the first Stop bit. After the Stop bit(s) of a frame, either the next frame can follow immediately, or the communication line can return to the Idle (high) state. The USART accepts all combinations of the following as valid frame formats:

- 1 Start bit
- 5, 6, 7, 8, or 9 data bits
- No, even, or odd Parity bit
- 1 or 2 Stop bits

The figure below illustrates the possible combinations of frame formats. Bits inside brackets are optional.

**Figure 25-2. Frame Formats**

**St** Start bit, always low

**(n)** Data bits (0 to 8)

**P** Parity bit, may be odd or even

**Sp** Stop bit, always high

**IDLE** No transfer on the communication line (RxD or TxD). The Idle state is always high.

**25.3.2.2 Clock Generation**

The clock used for shifting and sampling data bits is generated internally by the fractional baud rate generator or externally from the Transfer Clock (XCK) pin.

Figure 25-3. Clock Generation Logic Block Diagram



25.3.2.2.1 The Fractional Baud Rate Generator

In modes where the USART is not using the XCK input as a clock source, the fractional Baud Rate Generator is used to generate the clock. Baud rate is given in terms of bits per second (bps) and is configured by writing the USARTn.BAUD register. The baud rate ( $f_{BAUD}$ ) is generated by dividing the peripheral clock ( $f_{CLK\_PER}$ ) by a division factor decided by the BAUD register.

The fractional Baud Rate Generator features hardware that accommodates cases where  $f_{CLK\_PER}$  is not divisible by  $f_{BAUD}$ . Usually, this situation would lead to a rounding error. The fractional Baud Rate Generator expects the BAUD register to contain the desired division factor left shifted by six bits, as implemented by the equations in Table 25-1. The six LSBs will then hold the fractional part of the desired divisor. The fractional part of the BAUD register is used to dynamically adjust  $f_{BAUD}$  to achieve a closer approximation to the desired baud rate.

Since the baud rate cannot be higher than  $f_{CLK\_PER}$ , the integer part of the BAUD register needs to be at least 1. Since the result is left shifted by six bits, the corresponding minimum value of the BAUD register is 64. The valid range is, therefore, 64 to 65535.

In Synchronous mode, only the 10-bit integer part of the BAUD register (BAUD[15:6]) determines the baud rate, and the fractional part (BAUD[5:0]) must, therefore, be written to zero.

The table below lists equations for translating baud rates into input values for the BAUD register. The equations take fractional interpretation into consideration, so the BAUD values calculated with these equations can be written directly to USARTn.BAUD without any additional scaling.

Table 25-1. Equations for Calculating Baud Rate Register Setting

Operating Mode	Conditions	Baud Rate (Bits Per Seconds)	USART.BAUD Register Value Calculation
Asynchronous	$f_{BAUD} \leq \frac{f_{CLK\_PER}}{S}$ $USART.BAUD \geq 64$	$f_{BAUD} = \frac{64 \times f_{CLK\_PER}}{S \times BAUD}$	$BAUD = \frac{64 \times f_{CLK\_PER}}{S \times f_{BAUD}}$
Synchronous Master	$f_{BAUD} \leq \frac{f_{CLK\_PER}}{S}$ $USART.BAUD \geq 64$	$f_{BAUD} = \frac{f_{CLK\_PER}}{S \times BAUD[15:6]}$	$BAUD[15:6] = \frac{f_{CLK\_PER}}{S \times f_{BAUD}}$



S is the number of samples per bit

- Asynchronous Normal mode: S = 16
- Asynchronous Double-Speed mode: S = 8
- Synchronous mode: S = 2

### 25.3.2.3 Data Transmission

The USART transmitter sends data by periodically driving the transmission line low. The data transmission is initiated by loading the transmit buffer (USARTn.TXDATA) with the data to be sent. The data in the transmit buffer is moved to the Shift register once it is empty and ready to send a new frame. After the Shift register is loaded with data, the data frame will be transmitted.

When the entire frame in the Shift register has been shifted out, and there are no new data present in the transmit buffer, the Transmit Complete Interrupt Flag (the TXCIF bit in the USARTn.STATUS register) is set, and the interrupt is generated if it is enabled.

TXDATA can only be written when the Data Register Empty Interrupt Flag (the DREIF bit in the USARTn.STATUS register) is set, indicating that the register is empty and ready for new data.

When using frames with fewer than eight bits, the Most Significant bits (MSb) written to TXDATA are ignored. If 9-bit characters are used, the DATA[8] bit in the USARTn.TXDATAH register has to be written before the DATA[7:0] bits in the USARTn.TXDATAL register.

#### 25.3.2.3.1 Disabling the Transmitter

When disabling the transmitter, the operation will not become effective until ongoing and pending transmissions are completed (that is, when the Transmit Shift register and Transmit Buffer register do not contain data to be transmitted). When the transmitter is disabled, it will no longer override the TXD pin, and the PORT module regains control of the pin. The pin is automatically configured as an input by hardware regardless of its previous setting. The pin can now be used as a normal I/O pin with no port override from the USART.

### 25.3.2.4 Data Reception

The USART receiver samples the reception line to detect and interpret the received data. The direction of the pin must, therefore, be configured as an input by writing a '0' to the corresponding bit in the Direction register (PORTx.DIRn).

The receiver accepts data when a valid Start bit is detected. Each bit that follows the Start bit will be sampled at the baud rate or XCK clock and shifted into the Receive Shift register until the first Stop bit of a frame is received. A second Stop bit will be ignored by the receiver. When the first Stop bit is received, and a complete serial frame is present in the Receive Shift register, the contents of the Shift register will be moved into the receive buffer. The Receive Complete Interrupt Flag (the RXCIF bit in the USARTn.STATUS register) is set, and the interrupt is generated if enabled.

The RXDATA registers are the part of the double-buffered RX buffer that can be read by the application software when RXCIF is set. If only one frame has been received, the data and status bits for that frame are pushed to the RXDATA registers directly. If two frames are present in the RX buffer, the RXDATA registers contain the data for the oldest frame.

The buffer shifts out the data either when RXDATAL or RXDATAH is read, depending on the configuration. The register, which does not lead to data being shifted, should be read first to be able to read both bytes before shifting. When the Character Size (CHSIZE) bits in the Control C (USARTn.CTRLA) register is configured to 9-bit (low byte first), a read of RXDATAH shifts the receive buffer. Otherwise, RXDATAL shifts the buffer.

#### 25.3.2.4.1 Receiver Error Flags

The USART receiver features error detection mechanisms that uncover corruption of the transmission. These mechanisms include the following:

- Frame Error detection - controls whether the received frame is valid
- Buffer Overflow detection - indicates data loss due to the receiver buffer being full and overwritten by the new data
- Parity Error detection - checks the validity of the incoming frame by calculating its parity and comparing it to the Parity bit

Each error detection mechanism controls one error flag that can be read in the RXDATAH register:

- Frame Error (FERR)

- Buffer Overflow (BUFOVF)
- Parity Error (PERR)

The error flags are located in the RX buffer together with their corresponding frame. The RXDATAH register that contains the error flags must be read before the RXDATAL register, since reading the RXDATAL register will trigger the RX buffer to shift out the RXDATA bytes.

**Note:** If the Character Size bit field (the CHSIZE bits in the USARTn.CTRLC register) is set to nine bits, low byte first (9BITL), the RXDATAH register will, instead of the RXDATAL register, trigger the RX buffer to shift out the RXDATA bytes. The RXDATAL register must, in that case, be read before the RXDATAH register.

**25.3.2.4.2 Disabling the Receiver**

When disabling the receiver, the operation is immediate. The receiver buffer will be flushed, and data from ongoing receptions will be lost.

**25.3.2.4.3 Flushing the Receive Buffer**

If the RX buffer has to be flushed during normal operation, repeatedly read the DATA location (USARTn.RXDATAH and USARTn.RXDATAL registers) until the Receive Complete Interrupt Flag (the RXCIF bit in the USARTn.RXDATAH register) is cleared.

**25.3.3 Communication Modes**

The USART is a flexible peripheral that supports multiple different communication protocols. The available modes of operation can be split into two groups: Synchronous and asynchronous communication.

The synchronous communication relies on one device on the bus to be the master, providing the rest of the devices with a clock signal through the XCK pin. All the devices use this common clock signal for both transmission and reception, requiring no additional synchronization mechanism.

The device can be configured to run either as a master or a slave on the synchronous bus.

The asynchronous communication does not use a common clock signal. Instead, it relies on the communicating devices to be configured with the same baud rate. When receiving a transmission, the hardware synchronization mechanisms are used to align the incoming transmission with the receiving device peripheral clock.

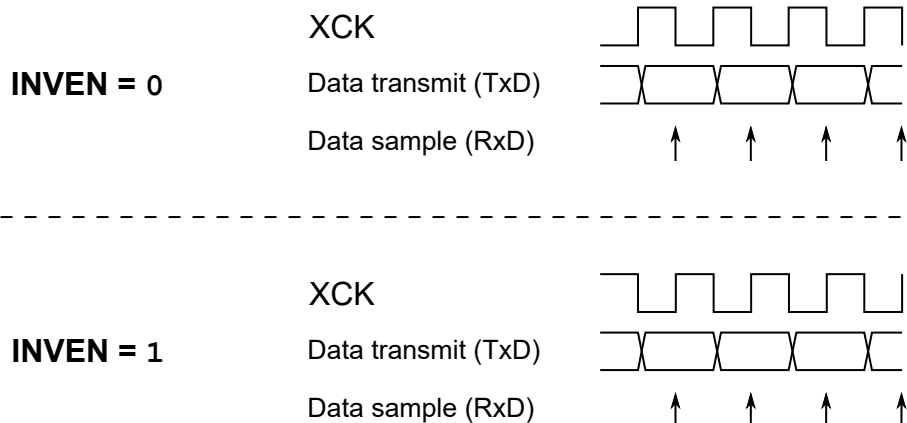
Four different modes of reception are available when communicating asynchronously. One of these modes can receive transmissions at twice the normal speed, sampling only eight times per bit instead of the normal 16. The other three operating modes use variations of synchronization logic, all receiving at normal speed.

**25.3.3.1 Synchronous Operation**

**25.3.3.1.1 Clock Operation**

The XCK pin direction controls whether the transmission clock is an input (Slave mode) or an output (Master mode). The corresponding port pin direction must be set to output for Master mode or to input for Slave mode (PORTx.DIRn). The data input (on RXD) is sampled at the XCK clock edge which is opposite the edge where data are transmitted (on TXD) as shown in the figure below.

**Figure 25-4. Synchronous Mode XCK Timing**



The I/O pin can be inverted by writing a '1' to the Inverted I/O Enable (INVEN) bit in the Pin n Control register of the port peripheral (PORTx.PINnCTRL). Using the inverted I/O setting for the corresponding XCK port pin, the XCK clock edges used for sampling RxD and transmitting on TxD can be selected. If the inverted I/O is disabled (INVEN = 0), the rising XCK clock edge represents the start of a new data bit, and the received data will be sampled at the falling XCK clock edge. If inverted I/O is enabled (INVEN = 1), the falling XCK clock edge represents the start of a new data bit, and the received data will be sampled at the rising XCK clock edge.

**25.3.3.1.2 External Clock Limitations**

When the USART is configured in Synchronous Slave mode, the XCK signal must be provided externally by the master device. Since the clock is provided externally, configuring the BAUD register will have no impact on the transfer speed. Successful clock recovery requires the clock signal to be sampled at least twice for each rising and falling edge. The maximum XCK speed in Synchronous Operation mode,  $f_{Slave\_XCK}$ , is therefore limited by:

$$f_{Slave\_XCK} < \frac{f_{CLK\_PER}}{4}$$

If the XCK clock has jitter, or if the high/low period duty cycle is not 50/50, the maximum XCK clock speed must be reduced accordingly to ensure that XCK is sampled a minimum of two times for each edge.

**25.3.3.1.3 USART in Master SPI Mode**

The USART may be configured to function with multiple different communication interfaces, and one of these is the Serial Peripheral Interface (SPI) where it can function as the master device. The SPI is a four-wire interface that enables a master device to communicate with one or multiple slaves.

**Frame Formats**

The serial frame for the USART in Master SPI mode always contains eight Data bits. The Data bits can be configured to be transmitted with either the LSb or MSb first, by writing to the Data Order bit (UDORD) in the Control C register (USARTn.CTRLC).

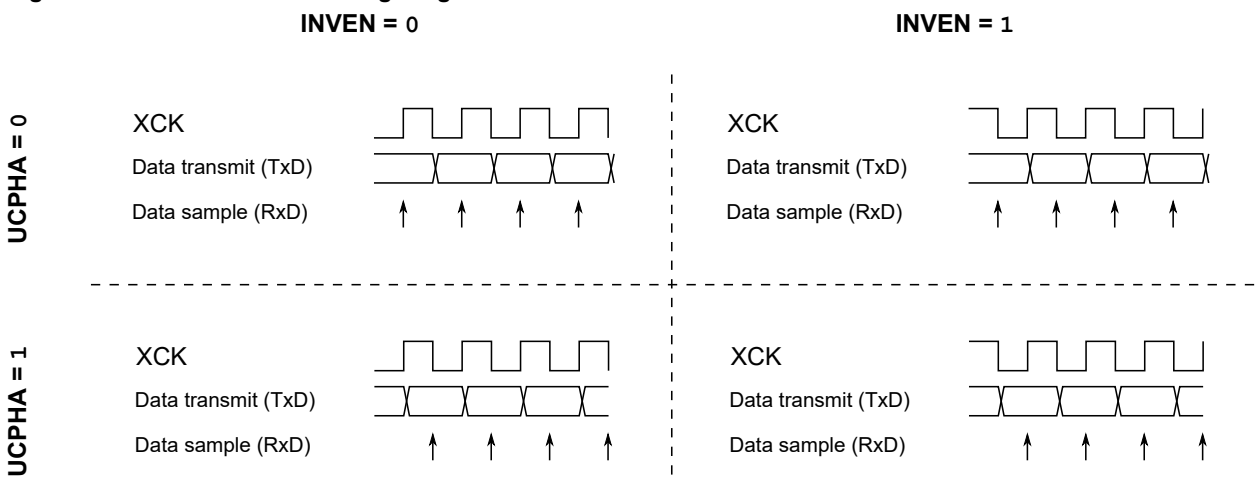
SPI does not use Start, Stop, or Parity bits, so the transmission frame can only consist of the Data bits.

**Clock Generation**

Being a master device in a synchronous communication interface, the USART in Master SPI mode must generate the interface clock to be shared with the slave devices. The interface clock is generated using the fractional Baud Rate Generator, which is described in [25.3.2.2.1 The Fractional Baud Rate Generator](#).

Each Data bit is transmitted by pulling the data line high or low for one full clock period. The receiver will sample bits in the middle of the transmitter hold period as shown in the figure below. It also shows how the timing scheme can be configured using the Inverted I/O Enable (INVEN) bit in the PORTx.PINnCTRL register and the USART Clock Phase (UCPHA) bit in the USARTn.CTRLC register.

**Figure 25-5. Data Transfer Timing Diagrams**



The table below further explains the figure above.

Table 25-2. Functionality of INVEN and UCPHA Bits

INVEN	UCPHA	Leading Edge <sup>(1)</sup>	Trailing Edge <sup>(1)</sup>
0	0	Rising, sample	Falling, transmit
0	1	Rising, transmit	Falling, sample
1	0	Falling, sample	Rising, transmit
1	1	Falling, transmit	Rising, sample

**Note:**

1. The leading edge is the first clock edge of a clock cycle. The trailing edge is the last clock edge of a clock cycle.

**Data Transmission**

Data transmission in Master SPI mode is functionally identical to general USART operation as described in the *Operation* section. The transmitter interrupt flags and corresponding USART interrupts are also identical. See [25.3.2.3 Data Transmission](#) for further description.

**Data Reception**

Data reception in Master SPI mode is identical in function to general USART operation as described in the *Operation* section. The receiver interrupt flags and the corresponding USART interrupts are also identical, aside from the receiver error flags that are not in use and always read as '0'. See [25.3.2.4 Data Reception](#) for further description.

**USART in Master SPI Mode vs. SPI**

The USART in Master SPI mode is fully compatible with a stand-alone SPI peripheral. Their data frame and timing configurations are identical. Some SPI specific special features are, however, not supported with the USART in Master SPI mode:

- Write Collision Flag Protection
- Double-Speed mode
- Multi-Master support

A comparison of the pins used with USART in Master SPI mode and with SPI is shown in the table below.

Table 25-3. Comparison of USART in Master SPI Mode and SPI Pins

USART	SPI	Comment
TXD	MOSI	Master out
RXD	MISO	Master in
XCK	SCK	Functionally identical
-	SS	Not supported by USART in Master SPI mode <sup>(1)</sup>

**Note:**

1. For the stand-alone SPI peripheral, this pin is used with the Multi-Master function or as a dedicated Slave Select pin. The Multi-Master function is not available with the USART in Master SPI mode, and no dedicated Slave Select pin is available.

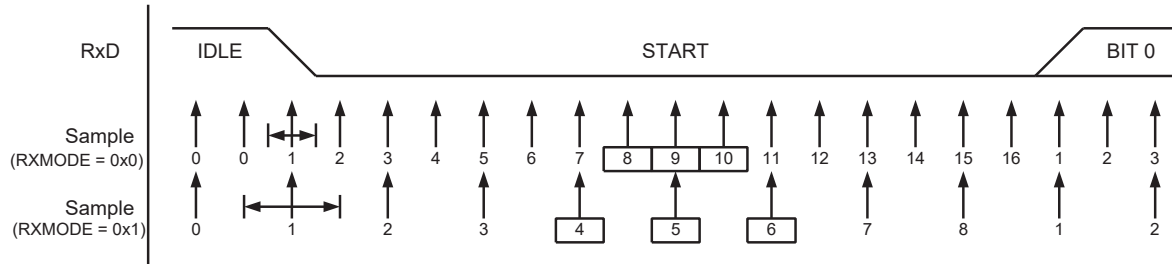
**25.3.3.2 Asynchronous Operation****25.3.3.2.1 Clock Recovery**

Since there is no common clock signal when using Asynchronous mode, each communicating device generates separate clock signals. These clock signals must be configured to run at the same baud rate for the communication to take place. The devices, therefore, run at the same speed, but their timing is skewed in relation to each other. To accommodate this, the USART features a hardware clock recovery unit which synchronizes the incoming asynchronous serial frames with the internally generated baud rate clock.

The figure below illustrates the sampling process for the Start bit of an incoming frame. It shows the timing scheme for both Normal and Double-Speed mode (the RXMODE bits in the USARTn.CTRLB register configured respectively

to 0x00 and 0x01). The sample rate for Normal mode is 16 times the baud rate, while the sample rate for Double-Speed mode is eight times the baud rate (see 25.3.3.2.4 Double-Speed Operation for more details). The horizontal arrows show the maximum synchronization error. Note that the maximum synchronization error is larger in Double-Speed mode.

Figure 25-6. Start Bit Sampling

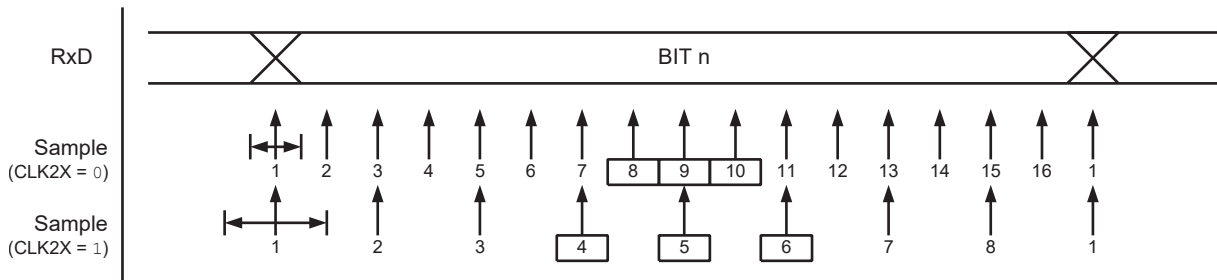


When the clock recovery logic detects a falling edge from Idle (high) state to the Start bit (low), the Start bit detection sequence is initiated. In the figure above, sample 1 denotes the first sample reading '0'. The clock recovery logic then uses three subsequent samples (samples 8, 9, and 10 in Normal mode, and samples 4, 5, 6 in Double-Speed mode) to decide if a valid Start bit is received. If two or three samples read '0', the Start bit is accepted. The clock recovery unit is synchronized, and the data recovery can begin. If less than two samples read '0', the Start bit is rejected. This process is repeated for each Start bit.

25.3.3.2.2 Data Recovery

As with clock recovery, the data recovery unit samples at a rate 8 or 16 times faster than the baud rate depending on whether it is running in Double-Speed or Normal mode, respectively. The figure below shows the sampling process for reading a bit in a received frame.

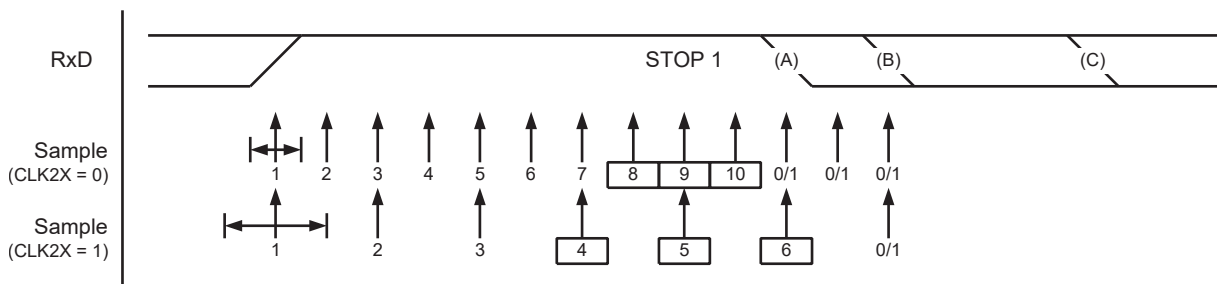
Figure 25-7. Sampling of Data and Parity Bits



A majority voting technique is, like with clock recovery, used on the three center samples for deciding the logic level of the received bit. The process is repeated for each bit until a complete frame is received.

The data recovery unit will only receive the first Stop bit while ignoring the rest if there are more. If the sampled Stop bit is read '0', the Frame Error flag will be set. The figure below shows the sampling of a Stop bit. It also shows the earliest possible beginning of the next frame's Start bit.

Figure 25-8. Stop Bit and Next Start Bit Sampling



A new high-to-low transition indicating the Start bit of a new frame can come right after the last of the bits used for majority voting. For Normal-Speed mode, the first low-level sample can be at the point marked (A) in the figure above. For Double-Speed mode the first low level must be delayed to point (B), being the first sample after the majority vote samples. Point (C) marks a Stop bit of full length at the nominal baud rate.

**25.3.3.2.3 Error Tolerance**

The speed of the internally generated baud rate and the externally received data rate should ideally be identical, but due to natural clock source error, this is normally not the case. The USART is tolerant of such error, and the limits of this tolerance make up what is sometimes known as the Operational Range.

The following tables list the operational range of the USART, being the maximum receiver baud rate error that can be tolerated. Note that Normal-Speed mode has higher toleration of baud rate variations than Double-Speed mode.

**Table 25-4. Recommended Maximum Receiver Baud Rate Error for Normal Speed Mode**

D	R <sub>slow</sub> [%]	R <sub>fast</sub> [%]	Maximum Total Error [%]	Recommended Max. Receiver Error [%]
5	93.20	106.67	-6.80/+6.67	±3.0
6	94.12	105.79	-5.88/+5.79	±2.5
7	94.81	105.11	-5.19/+5.11	±2.0
8	95.36	104.58	-4.54/+4.58	±2.0
9	95.81	104.14	-4.19/+4.14	±1.5
10	96.17	103.78	-3.83/+3.78	±1.5

**Notes:**

- D: The sum of character size and parity size (D = 5 to 10 bits)
- R<sub>SLOW</sub>: The ratio of the slowest incoming data rate that can be accepted in relation to the receiver baud rate
- R<sub>FAST</sub>: The ratio of the fastest incoming data rate that can be accepted in relation to the receiver baud rate

**Table 25-5. Recommended Maximum Receiver Baud Rate Error for Double Speed Mode**

D	R <sub>slow</sub> [%]	R <sub>fast</sub> [%]	Maximum Total Error [%]	Recommended Max. Receiver Error [%]
5	94.12	105.66	-5.88/+5.66	±2.5
6	94.92	104.92	-5.08/+4.92	±2.0
7	95.52	104.35	-4.48/+4.35	±1.5
8	96.00	103.90	-4.00/+3.90	±1.5
9	96.39	103.53	-3.61/+3.53	±1.5
10	96.70	103.23	-3.30/+3.23	±1.0

**Notes:**

- D: The sum of character size and parity size (D = 5 to 10 bits)
- R<sub>SLOW</sub>: The ratio of the slowest incoming data rate that can be accepted in relation to the receiver baud rate
- R<sub>FAST</sub>: The ratio of the fastest incoming data rate that can be accepted in relation to the receiver baud rate

The recommendations of the maximum receiver baud rate error were made under the assumption that the receiver and transmitter equally divide the maximum total error.

The following equations are used to calculate the maximum ratio of the incoming data rate and the internal receiver baud rate.

$R_{SLOW} = \frac{S(D+1)}{S(D+1) + S_F - 1}$	$R_{FAST} = \frac{S(D+2)}{S(D+1) + S_M}$
--	--

- D: The sum of character size and parity size (D = 5 to 10 bits)
- S: Samples per bit. S = 16 for Normal Speed mode and S = 8 for Double-Speed mode.
- S<sub>F</sub>: First sample number used for majority voting. SF = 8 for Normal-Speed mode and SF = 4 for Double-Speed mode.

- $S_M$ : Middle sample number used for majority voting.  $SM = 9$  for Normal-Speed mode and  $SM = 5$  for Double-Speed mode.
- $R_{SLOW}$ : The ratio of the slowest incoming data rate that can be accepted in relation to the receiver baud rate
- $R_{FAST}$ : The ratio of the fastest incoming data rate that can be accepted in relation to the receiver baud rate

#### 25.3.3.2.4 Double-Speed Operation

Double-speed operation allows for higher baud rates under asynchronous operation with lower peripheral clock frequencies. This operation mode is enabled by writing the RXMODE bits in the Control B (USARTn.CTRLB) register to 0x01.

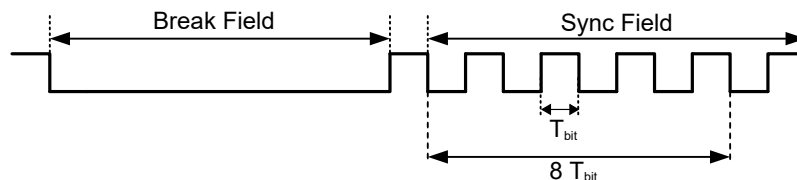
When enabled, the baud rate for a given asynchronous baud rate setting will be doubled. This is shown in the equations in [25.3.2.2.1 The Fractional Baud Rate Generator](#). In this mode, the receiver will use half the number of samples (reduced from 16 to 8) for data sampling and clock recovery. This requires a more accurate baud rate setting and peripheral clock. See [25.3.3.2.3 Error Tolerance](#) for more details.

#### 25.3.3.2.5 Auto-Baud

The auto-baud feature lets the USART configure its BAUD register based on input from a communication device. This allows the device to communicate autonomously with multiple devices communicating with different baud rates. The USART peripheral features two auto-baud modes: Generic Auto-Baud mode and LIN Constrained Auto-Baud mode.

Both auto-baud modes must receive an auto-baud frame as seen in the figure below.

**Figure 25-9. Auto-Baud Timing**



The break field is detected when 12 or more consecutive low cycles are sampled and notifies the USART that it is about to receive the synchronization field. After the break field, when the Start bit of the synchronization field is detected, a counter running at the peripheral clock speed is started. The counter is then incremented for the next eight  $T_{bit}$  of the synchronization field. When all eight bits are sampled, the counter is stopped. The resulting counter value is in effect the new BAUD register value.

When the USART Receive mode is set to GENAUTO (the RXMODE bits in the USARTn.CTRLB register), the Generic Auto-Baud mode is enabled. In this mode, one can set the Wait For Break (WFB) bit in the USARTn.STATUS register to enable detection of a break field of any length (that is, also shorter than 12 cycles). This makes it possible to set an arbitrary new baud rate without knowing the current baud rate. If the measured sync field results in a valid BAUD value (0x0064 - 0xFFFF), the BAUD register is updated.

When USART Receive mode is set to LINAUTO mode (the RXMODE bits in the USARTn.CTRLB register), it follows the LIN format. The WFB functionality of the Generic Auto-Baud mode is not compatible with the LIN Constrained Auto-Baud mode. This means that the received signal must be low for 12 peripheral clock cycles or more for a break field to be valid. When a break field has been detected, the USART expects the following synchronization field character to be 0x55. The tolerance for the difference in baud rates between the two synchronizing devices can be configured using the Auto-baud Window Size (ABW) bits in the Control D (USARTn.CTRLD) register. If any of these conditions are not met, the Inconsistent Sync Field Error Flag (the ISFIF bit in the USARTn.STATUS register) is set, and the baud rate is unchanged.

#### 25.3.3.2.6 Half Duplex Operation

Half duplex is a type of communication where two or more devices may communicate with each other, but only one at a time. The USART can be configured to operate in the following half duplex modes:

- One-Wire mode
- RS-485 mode

##### **One-Wire Mode**

One-Wire mode is enabled by setting the Loop-Back Mode Enable (LBME) bit in the USARTn.CTRLA register. This will enable an internal connection between the TXD pin and the USART receiver, making the TXD pin a combined

TxD/RxD line. The RXD pin will be disconnected from the USART receiver and may be controlled by a different peripheral.

In One-Wire mode, multiple devices are able to manipulate the TxD/RxD line at the same time. In the case where one device drives the pin to a logical high level ( $V_{CC}$ ), and another device pulls the line low (GND), a short will occur. To accommodate this, the USART features an Open-Drain mode (the ODME bit in the USARTn.CTRLB register) which prevents the transmitter from driving a pin to a logical high level, thereby constraining it to only be able to pull it low. Combining this function with the internal pull-up feature (the PULLUPEN bit in the PORTx.PINnCTRL register) will let the line be held high through a pull-up resistor, allowing any device to pull it low. When the line is pulled low the current from  $V_{CC}$  to GND will be limited by the pull-up resistor. The TXD pin is automatically set to output by hardware when the Open-Drain mode is enabled.

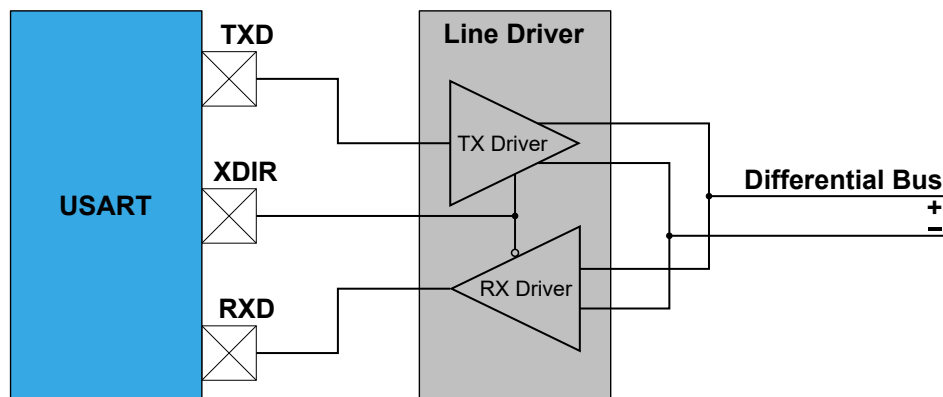
When the USART is transmitting to the TxD/RxD line, it will also receive its own transmission. This can be used to check for overlapping transmissions by checking if the received data are the same as the transmitted data as it should be.

### RS-485 Mode

RS-485 is a communication standard supported by the USART peripheral. It is a physical interface that defines the setup of a communication circuit. Data are transmitted using differential signaling, making communication robust against noise. RS-485 is enabled by writing the RS485 bit (USARTn.CTRLA) to '1'.

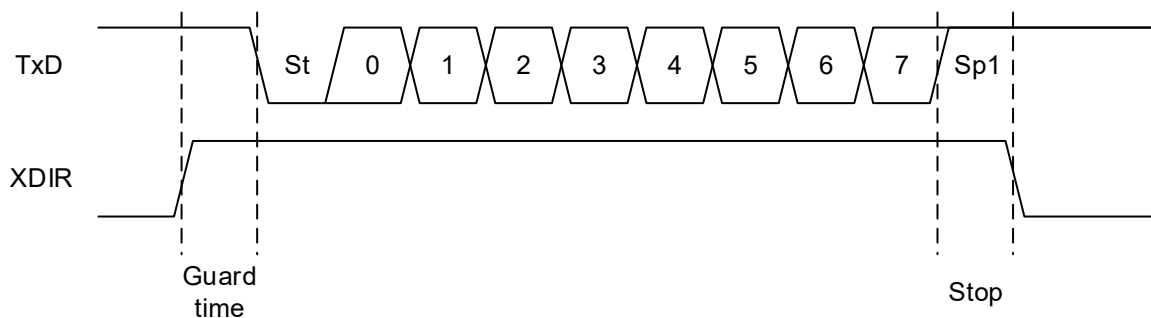
The RS-485 mode supports external line driver devices that convert a single USART transmission into corresponding differential pair signals. It implements automatic control of the XDIR pin that can be used to enable transmission or reception for the line driver device. The USART automatically drives the XDIR pin high while the USART is transmitting and pulls it low when the transmission is complete. An example of such a circuit is shown in the figure below.

Figure 25-10. RS-485 Bus Connection



The XDIR pin goes high one baud clock cycle in advance of data being shifted out to allow some guard time to enable the external line driver. The XDIR pin will remain high for the complete frame including Stop bit(s).

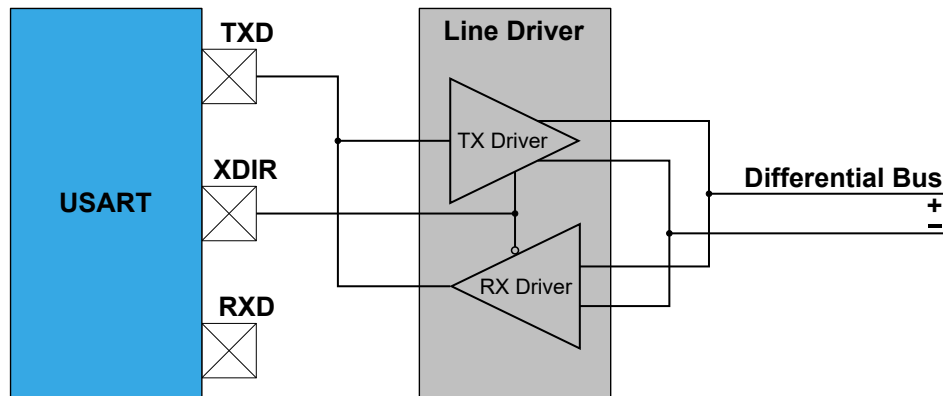
Figure 25-11. XDIR Drive Timing



RS-485 mode is compatible with One-Wire mode. One-Wire mode enables an internal connection between the TXD pin and the USART receiver, making the TXD pin a combined TxD/RxD line. The RXD pin will be disconnected from the USART receiver and may be controlled by a different peripheral. An example of such a circuit is shown in the figure below.



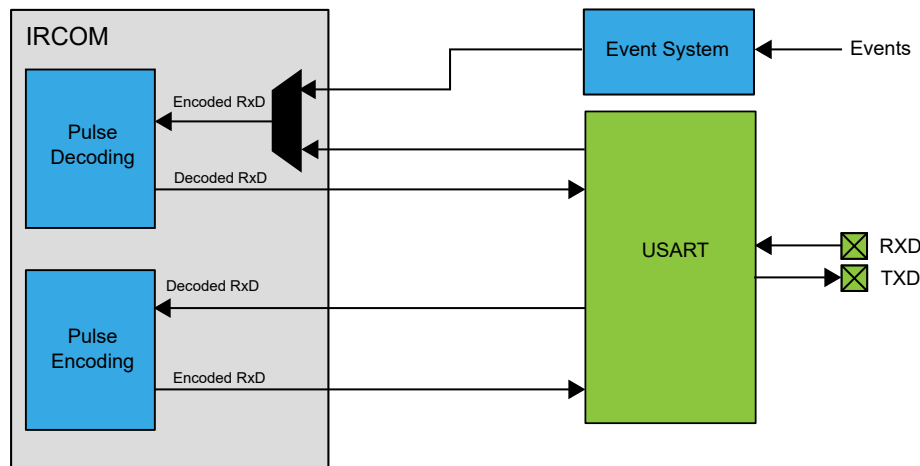
Figure 25-12. RS-485 with Loop-Back Mode Connection



### 25.3.3.2.7 IRCOM Mode of Operation

The USART peripheral can be configured in Infrared Communication mode (IRCOM) which is IrDA® 1.4 compatible with baud rates up to 115.2 kbps. When enabled, the IRCOM mode enables infrared pulse encoding/decoding for the USART.

Figure 25-13. Block Diagram



The USART is set in IRCOM mode by writing 0x02 to the CMODE bits in the USARTn.CTRLA register. The data on the TXD/RXD pins are the inverted values of the transmitted/received infrared pulse. It is also possible to select an event channel from the Event System as an input for the IRCOM receiver. This enables the IRCOM to receive input from the I/O pins or sources other than the corresponding RXD pin. This will disable the RxD input from the USART pin.

For transmission, three pulse modulation schemes are available:

- 3/16 of the baud rate period
- Fixed programmable pulse time based on the peripheral clock frequency
- Pulse modulation disabled

For the reception, a fixed programmable minimum high-level pulse-width for the pulse to be decoded as a logical '0' is used. Shorter pulses will then be discarded, and the bit will be decoded to logical '1' as if no pulse was received.

When IRCOM mode is enabled, Double-Speed mode cannot be used for the USART.

## 25.3.4 Additional Features

### 25.3.4.1 Parity

Parity bits can be used by the USART to check the validity of a data frame. The Parity bit is set by the transmitter based on the number of bits with the value of '1' in a transmission and controlled by the receiver upon reception. If

the Parity bit is inconsistent with the transmission frame, the receiver may assume that the data frame has been corrupted.

Even or odd parity can be selected for error checking by writing the Parity Mode (PMODE) bits in the USARTn.CTRLC register. If even parity is selected, the Parity bit is set to '1' if the number of Data bits with value '1' is odd (making the total number of bits with value '1' even). If odd parity is selected, the Parity bit is set to '1' if the number of data bits with value '1' is even (making the total number of bits with value '1' odd).

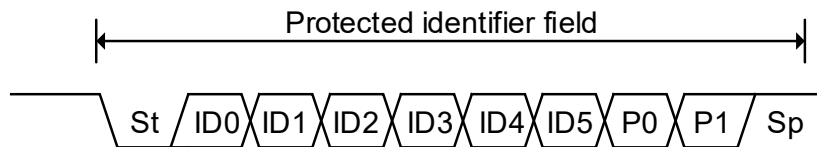
When enabled, the parity checker calculates the parity of the data bits in incoming frames and compares the result with the Parity bit of the corresponding frame. If a parity error is detected, the Parity Error flag (the PERR bit in the USARTn.RXDATAH register) is set.

If LIN Constrained Auto-Baud mode is enabled (RXMODE = 0x03 in the USARTn.CTRLB register), a parity check is only performed on the protected identifier field. A parity error is detected if one of the equations below is not true, which sets the Parity Error flag.

$$P0 = ID0 \text{ XOR } ID1 \text{ XOR } ID2 \text{ XOR } ID4$$

$$P1 = \text{NOT} (ID1 \text{ XOR } ID3 \text{ XOR } ID4 \text{ XOR } ID5)$$

Figure 25-14. Protected Identifier Field and Mapping of Identifier and Parity Bits



### 25.3.4.2 Start-of-Frame Detection

The Start-of-Frame Detection feature enables the USART to wake up from Standby sleep mode upon data reception.

When a high-to-low transition is detected on the RXD pin, the oscillator is powered up, and the USART peripheral clock is enabled. After start-up, the rest of the data frame can be received, provided that the baud rate is slow enough in relation to the oscillator start-up time. The start-up time of the oscillators varies with supply voltage and temperature. For details on oscillator start-up time characteristics, refer to the *Electrical Characteristics* section.

If a false Start bit is detected, the device will, if another wake-up source has not been triggered, go back into the Standby sleep mode.

The Start-of-Frame detection works in Asynchronous mode only. It is enabled by writing the Start-of-Frame Detection Enable (SFDEN) bit in the USARTn.CTRLB register. If a Start bit is detected while the device is in Standby sleep mode, the USART Receive Start Interrupt Flag (RXSIF) bit is set.

The USART Receive Complete Interrupt Flag (RXCIF) bit and the RXSIF bit share the same interrupt line, but each has its dedicated interrupt settings. The table below shows the USART Start Frame Detection modes, depending on the interrupt setting.

Table 25-6. USART Start Frame Detection Modes

SFDEN	RXSIF Interrupt	RXCIF Interrupt	Comment
0	x	x	Standard mode
1	Disabled	Disabled	Only the oscillator is powered during the frame reception. If the interrupts are disabled and buffer overflow is ignored, all incoming frames will be lost
1	Disabled	Enabled	System/all clocks are awakened on Receive Complete interrupt
1	Enabled	x	System/all clocks are awakened when a Start bit is detected

**Note:** The SLEEP instruction will not shut down the oscillator if there is ongoing communication.

### 25.3.4.3 Multiprocessor Communication

The Multiprocessor Communication mode (MPCM) effectively reduces the number of incoming frames that have to be handled by the receiver in a system with multiple microcontrollers communicating via the same serial bus. This

mode is enabled by writing a '1' to the MPCM bit in the Control B register (USARTn.CTRLB). In this mode, a dedicated bit in the frames is used to indicate whether the frame is an address or data frame type.

If the receiver is set up to receive frames that contain five to eight data bits, the first Stop bit is used to indicate the frame type. If the receiver is set up for frames with nine data bits, the ninth bit is used to indicate frame type. When the frame type bit is '1', the frame contains an address. When the frame type bit is '0', the frame is a data frame. If 5- to 8-bit character frames are used, the transmitter must be set to use two Stop bits, since the first Stop bit is used for indicating the frame type.

If a particular slave MCU has been addressed, it will receive the following data frames as usual, while the other slave MCUs will ignore the frames until another address frame is received.

#### 25.3.4.3.1 Using Multiprocessor Communication

The following procedure should be used to exchange data in Multiprocessor Communication mode (MPCM):

1. All slave MCUs are in Multiprocessor Communication mode.
2. The master MCU sends an address frame, and all slaves receive and read this frame.
3. Each slave MCU determines if it has been selected.
4. The addressed MCU will disable MPCM and receive all data frames. The other slave MCUs will ignore the data frames.
5. When the addressed MCU has received the last data frame, it must enable MPCM again and wait for a new address frame from the master.

The process then repeats from step 2.

#### 25.3.5 Events

The USART can generate the events described in the table below.

**Table 25-7. Event Generators in USART**

Generator Name		Description	Event Type	Generating Clock Domain	Length of Event
Peripheral	Event				
USARTn	XCK	The clock signal in SPI Master mode and Synchronous USART Master mode	Pulse	CLK_PER	One XCK period

The table below describes the event user and its associated functionality.

**Table 25-8. Event Users in USART**

User Name		Description	Input Detection	Async/Sync
Peripheral	Input			
USARTn	IREI	USARTn IrDA event input	Pulse	Sync

#### 25.3.6 Interrupts

**Table 25-9. Available Interrupt Vectors and Sources**

Name	Vector Description	Conditions
RXC	Receive Complete interrupt	<ul style="list-style-type: none"> <li>• There is unread data in the receive buffer (RXCIE)</li> <li>• Receive of Start-of-Frame detected (RXSIE)</li> <li>• Auto-Baud Error/ISFIF flag set (ABEIE)</li> </ul>
DRE	Data Register Empty interrupt	The transmit buffer is empty/ready to receive new data (DREIE)
TXC	Transmit Complete interrupt	The entire frame in the Transmit Shift register has been shifted out and there are no new data in the transmit buffer (TXCIE)

When an Interrupt condition occurs, the corresponding Interrupt flag is set in the STATUS register (USARTn.STATUS).

An interrupt source is enabled or disabled by writing to the corresponding bit in the Control A register (USARTn.CTRLA).

An interrupt request is generated when the corresponding interrupt source is enabled, and the Interrupt flag is set. The interrupt request remains active until the Interrupt flag is cleared. See the USARTn.STATUS register for details on how to clear Interrupt flags.

### 25.4 Register Summary

Offset	Name	Bit Pos.	7	6	5	4	3	2	1	0
0x00	<a href="#">RXDATA</a>	7:0	DATA[7:0]							
0x01	<a href="#">RXDATAH</a>	7:0	RXCIF	BUFOVF				FERR	PERR	DATA[8]
0x02	<a href="#">TXDATA</a>	7:0	DATA[7:0]							
0x03	<a href="#">TXDATAH</a>	7:0								DATA[8]
0x04	<a href="#">STATUS</a>	7:0	RXCIF	TXCIF	DREIF	RXSIF	ISFIF		BDF	WFB
0x05	<a href="#">CTRLA</a>	7:0	RXCIE	TXCIE	DREIE	RXSIE	LBME	ABEIE		RS485
0x06	<a href="#">CTRLB</a>	7:0	RXEN	TXEN		SFDEN	ODME	RXMODE[1:0]		MPCM
0x07	<a href="#">CTRLC</a>	7:0	CMODE[1:0]		PMODE[1:0]		SBMODE	CHSIZE[2:0]		
0x07	<a href="#">CTRLC</a>	7:0	CMODE[1:0]					UDORD	UCPHA	
0x08	<a href="#">BAUD</a>	7:0	BAUD[7:0]							
		15:8	BAUD[15:8]							
0x0A	<a href="#">CTRLD</a>	7:0	ABW[1:0]							
0x0B	<a href="#">DBGCTRL</a>	7:0								DBGRUN
0x0C	<a href="#">EVCTRL</a>	7:0								IREI
0x0D	<a href="#">TXPLCTRL</a>	7:0	TXPL[7:0]							
0x0E	<a href="#">RXPLCTRL</a>	7:0		RXPL[6:0]						

### 25.5 Register Description

25.5.1 Receiver Data Register Low Byte

**Name:** RXDATA  
**Offset:** 0x00  
**Reset:** 0x00  
**Property:** -

This register contains the eight LSbs of the data received by the USART receiver. The USART receiver is double-buffered, and this register always represents the data for the oldest received frame. If the data for only one frame is present in the receive buffer, this register contains that data.

The buffer shifts out the data either when RXDATA or RXDATAH is read, depending on the configuration. The register, which does not lead to data being shifted, should be read first to be able to read both bytes before shifting.

When the Character Size (CHSIZE) bits in the Control C (USARTn.CTRLA) register is configured to 9-bit (low byte first), a read of RXDATAH shifts the receive buffer. Otherwise, RXDATA shifts the buffer.

Bit	7	6	5	4	3	2	1	0
	DATA[7:0]							
Access	R	R	R	R	R	R	R	R
Reset	0	0	0	0	0	0	0	0

**Bits 7:0 – DATA[7:0]** Receiver Data Register

### 25.5.2 Receiver Data Register High Byte

**Name:** RXDATAH  
**Offset:** 0x01  
**Reset:** 0x00  
**Property:** -

This register contains the MSb of the data received by the USART receiver, as well as status bits reflecting the status of the received data frame. The USART receiver is double-buffered, and this register always represents the data and status bits for the oldest received frame. If the data and status bits for only one frame is present in the receive buffer, this register contains that data.

The buffer shifts out the data either when RXDATAL or RXDATAH is read, depending on the configuration. The register, which does not lead to data being shifted, should be read first to be able to read both bytes before shifting.

When the Character Size (CHSIZE) bits in the Control C (USARTn.CTRLC) register is configured to 9-bit (low byte first), a read of RXDATAH shifts the receive buffer. Otherwise, RXDATAL shifts the buffer.

Bit	7	6	5	4	3	2	1	0
	RXCIF	BUFOVF				FERR	PERR	DATA[8]
Access	R	R				R	R	R
Reset	0	0				0	0	0

#### Bit 7 – RXCIF USART Receive Complete Interrupt Flag

This flag is set when there are unread data in the receive buffer and cleared when the receive buffer is empty.

#### Bit 6 – BUFOVF Buffer Overflow

This flag is set if a buffer overflow is detected. A buffer overflow occurs when the receive buffer is full, a new frame is waiting in the receive shift register, and a new Start bit is detected. This flag is cleared when the Receiver Data (USARTn.RXDATAL and USARTn.RXDATAH) registers are read.

This flag is not used in the Master SPI mode of operation.

#### Bit 2 – FERR Frame Error

This flag is set if the first Stop bit is '0' and cleared when it is correctly read as '1'.

This flag is not used in the Master SPI mode of operation.

#### Bit 1 – PERR Parity Error

This flag is set if parity checking is enabled, and the received data has a parity error. This flag is otherwise cleared.

For details on parity calculation, refer to [25.3.4.1 Parity](#).

This flag is not used in the Master SPI mode of operation.

#### Bit 0 – DATA[8] Receiver Data Register

When using a 9-bit frame size, this bit holds the ninth bit (MSb) of the received data.

When the Receiver Mode (RXMODE) bits in the Control B (USARTn.CTRLB) register is configured to LIN Constrained Auto-Baud (LINAUTO) mode, this bit indicates if the received data are within the response space of a LIN frame. This bit is cleared if the received data are in the protected identifier field and is otherwise set.

**25.5.3 Transmit Data Register Low Byte**

**Name:** TXDATAL  
**Offset:** 0x02  
**Reset:** 0x00  
**Property:** -

The data written to this register is automatically loaded into the dedicated shift register. The shift register outputs each of the bits serially to the TXD pin.

When using a 9-bit frame size, the ninth bit (MSb) should be written to USARTn.TXDATAH. In that case, the buffer shifts data either when TXDATAL or TXDATAH is written, depending on the configuration. The register, which does not lead to data being shifted, should be written first to be able to write both registers before shifting.

When the Character Size (CHSIZE) bits in the Control C (USARTn.CTRLA) register is configured to 9-bit (low byte first), a write of TXDATAH shifts the transmit buffer. Otherwise, TXDATAL shifts the buffer.

This register may only be written when the Data Register Empty Interrupt Flag (DREIF) in the Status (USARTn.STATUS) register is set.

Bit	7	6	5	4	3	2	1	0
	DATA[7:0]							
Access	R/W	R/W	R/W	R/W	R/W	R/W	R/W	R/W
Reset	0	0	0	0	0	0	0	0

**Bits 7:0 – DATA[7:0]** Transmit Data Register



**25.5.4 Transmit Data Register High Byte**

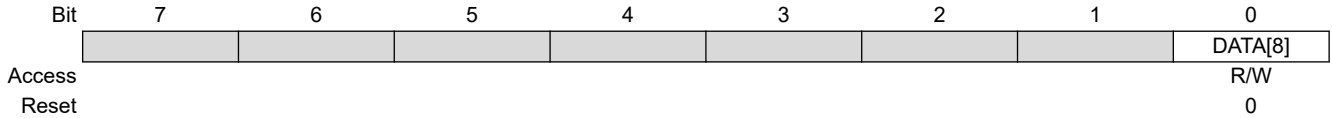
**Name:** TXDATAH  
**Offset:** 0x03  
**Reset:** 0x00  
**Property:** -

The data written to this register is automatically loaded into the dedicated shift register. The shift register outputs each of the bits serially to the TXD pin.

When using a 9-bit frame size, the ninth bit (MSb) should be written to USARTn.TXDATAH. In that case, the buffer shifts data either when TXDATAL or TXDATAH is written, depending on the configuration. The register, which does not lead to data being shifted, should be written first to be able to write both bytes before shifting.

When the Character Size (CHSIZE) bits in the Control C (USARTn.CTRLA) register is configured to 9-bit (low byte first), a write of TXDATAH shifts the transmit buffer. Otherwise, TXDATAL shifts the buffer.

This register may only be written when the Data Register Empty Interrupt Flag (DREIF) in the Status (USARTn.STATUS) register is set.



**Bit 0 – DATA[8]** Transmit Data Register

## 25.5.5 USART Status Register

**Name:** STATUS  
**Offset:** 0x04  
**Reset:** 0x00  
**Property:** -

Bit	7	6	5	4	3	2	1	0
	RXCIF	TXCIF	DREIF	RXSIF	ISFIF		BDF	WFB
Access	R	R/W	R	R/W	R/W		R/W	W
Reset	0	0	1	0	0		0	0

**Bit 7 – RXCIF** USART Receive Complete Interrupt Flag

This flag is set when there are unread data in the receive buffer and cleared when the receive buffer is empty.

**Bit 6 – TXCIF** USART Transmit Complete Interrupt Flag

This flag is set when the entire frame in the Transmit Shift register has been shifted out, and there are no new data in the transmit buffer (TXDATAL and TXDATAH) registers. It is cleared by writing a '1' to it.

**Bit 5 – DREIF** USART Data Register Empty Interrupt Flag

This flag is set when the transmit buffer (TXDATAL and TXDATAH) registers are empty and cleared when they contain data that has not yet been moved into the transmit shift register.

**Bit 4 – RXSIF** USART Receive Start Interrupt Flag

This flag is set when Start-of-Frame detection is enabled, the device is in Standby sleep mode, and a valid start bit is detected. It is cleared by writing a '1' to it.

This flag is not used in the Master SPI mode operation.

**Bit 3 – ISFIF** Inconsistent Synchronization Field Interrupt Flag

This flag is set if an auto-baud mode is enabled, and the synchronization field is too short or too long to give a valid baud setting. It will also be set when USART is set to LIN AUTO mode, and the SYNC character differs from data value 0x55. This flag is cleared by writing a '1' to it. See section [25.3.3.2.5 Auto-Baud](#) for more information.

**Bit 1 – BDF** Break Detected Flag

This flag is set if an auto-baud mode is enabled and a valid break and synchronization character is detected, and is cleared when the next data is received. It can also be cleared by writing a '1' to it. See section [25.3.3.2.5 Auto-Baud](#) for more information.

**Bit 0 – WFB** Wait For Break

This bit controls whether the Wait For Break feature is enabled or not. Refer to section [25.3.3.2.5 Auto-Baud](#) for more information.

Value	Description
0	Wait For Break is disabled
1	Wait For Break is enabled

## 25.5.6 Control A

**Name:** CTRLA  
**Offset:** 0x05  
**Reset:** 0x00  
**Property:** -

Bit	7	6	5	4	3	2	1	0
	RXCIE	TXCIE	DREIE	RXSIE	LBME	ABEIE		RS485
Access	R/W	R/W	R/W	R/W	R/W	R/W		R/W
Reset	0	0	0	0	0	0		0

**Bit 7 – RXCIE** Receive Complete Interrupt Enable

This bit controls whether the Receive Complete Interrupt is enabled or not. When enabled, the interrupt will be triggered when the RXCIF bit in the USARTn.STATUS register is set.

Value	Description
0	The Receive Complete Interrupt is disabled
1	The Receive Complete Interrupt is enabled

**Bit 6 – TXCIE** Transmit Complete Interrupt Enable

This bit controls whether the Transmit Complete Interrupt is enabled or not. When enabled, the interrupt will be triggered when the TXCIF bit in the USARTn.STATUS register is set.

Value	Description
0	The Transmit Complete Interrupt is disabled
1	The Transmit Complete Interrupt is enabled

**Bit 5 – DREIE** Data Register Empty Interrupt Enable

This bit controls whether the Data Register Empty Interrupt is enabled or not. When enabled, the interrupt will be triggered when the DREIF bit in the USARTn.STATUS register is set.

Value	Description
0	The Data Register Empty Interrupt is disabled
1	The Data Register Empty Interrupt is enabled

**Bit 4 – RXSIE** Receiver Start Frame Interrupt Enable

This bit controls whether the Receiver Start Frame Interrupt is enabled or not. When enabled, the interrupt will be triggered when the RXSIF bit in the USARTn.STATUS register is set.

Value	Description
0	The Receiver Start Frame Interrupt is disabled
1	The Receiver Start Frame Interrupt is enabled

**Bit 3 – LBME** Loop-back Mode Enable

This bit controls whether the Loop-back mode is enabled or not. When enabled, an internal connection between the TXD pin and the USART receiver is created, and the input from the RXD pin to the USART receiver is disconnected.

Value	Description
0	Loop-back mode is disabled
1	Loop-back mode is enabled

**Bit 2 – ABEIE** Auto-baud Error Interrupt Enable

This bit controls whether the Auto-baud Error Interrupt is enabled or not. When enabled, the interrupt will be triggered when the ISFIF bit in the USARTn.STATUS register is set.

Value	Description
0	The Auto-baud Error Interrupt is disabled
1	The Auto-baud Error Interrupt is enabled

**Bit 0 – RS485** RS-485 Mode

This bit controls whether the RS-485 mode is enabled or not. Refer to section [RS-485 Mode](#) for more information.

---

---

<b>Value</b>	<b>Description</b>
0	RS-485 mode is disabled
1	RS-485 mode is enabled

## 25.5.7 Control B

**Name:** CTRLB  
**Offset:** 0x06  
**Reset:** 0x00  
**Property:** -

Bit	7	6	5	4	3	2	1	0
	RXEN	TXEN		SFDEN	ODME	RXMODE[1:0]		MPCM
Access	R/W	R/W		R/W	R/W	R/W	R/W	R/W
Reset	0	0		0	0	0	0	0

**Bit 7 – RXEN** Receiver Enable

This bit controls whether the USART receiver is enabled or not. Refer to section [25.3.2.4.2 Disabling the Receiver](#) for more information.

Value	Description
0	The USART receiver is disabled
1	The USART receiver is enabled

**Bit 6 – TXEN** Transmitter Enable

This bit controls whether the USART transmitter is enabled or not. Refer to section [25.3.2.3.1 Disabling the Transmitter](#) for more information.

Value	Description
0	The USART transmitter is disabled
1	The USART transmitter is enabled

**Bit 4 – SFDEN** Start-of-Frame Detection Enable

This bit controls whether the USART Start-of-Frame Detection mode is enabled or not. Refer to section [25.3.4.2 Start-of-Frame Detection](#) for more information.

Value	Description
0	The USART Start-of-Frame Detection mode is disabled
1	The USART Start-of-Frame Detection mode is enabled

**Bit 3 – ODME** Open Drain Mode Enable

This bit controls whether Open Drain mode is enabled or not. See section [One-Wire Mode](#) for more information.

Value	Description
0	Open Drain mode is disabled
1	Open Drain mode is enabled

**Bits 2:1 – RXMODE[1:0]** Receiver Mode

Writing these bits selects the receiver mode of the USART.

- Writing the bits to 0x00 enables Normal-Speed (NORMAL) mode. When the USART Communication Mode (CMODE) bits in the Control C (USARTn.CTRLC) register is configured to Asynchronous USART (ASYNCHRONOUS) or Infrared Communication (IRCOM), the RXMODE bits should always be written to 0x00.
- Writing the bits to 0x01 enables Double-Speed (CLK2X) mode. Refer to section [25.3.3.2.4 Double-Speed Operation](#) for more information.
- Writing the bits to 0x02 enables Generic Auto-Baud (GENAUTO) mode. Refer to section [25.3.3.2.5 Auto-Baud](#) for more information.
- Writing the bits to 0x03 enables Lin Constrained Auto-Baud (LINAUTO) mode. Refer to section [25.3.3.2.5 Auto-Baud](#) for more information.

Value	Name	Description
0x00	NORMAL	Normal-Speed mode
0x01	CLK2X	Double-Speed mode
0x02	GENAUTO	Generic Auto-Baud mode
0x03	LINAUTO	LIN Constrained Auto-Baud mode

**Bit 0 – MPCM** Multi-Processor Communication Mode

This bit controls whether the Multi-Processor Communication mode is enabled or not. Refer to section [25.3.4.3 Multiprocessor Communication](#) for more information.

Value	Description
0	Multi-Processor Communication mode is disabled
1	Multi-Processor Communication mode is enabled

## 25.5.8 Control C - Normal Mode

**Name:** CTRLC  
**Offset:** 0x07  
**Reset:** 0x03  
**Property:** -

This register description is valid for all modes except the Master SPI mode. When the USART Communication Mode bits (CMODE) in this register are written to 'MSPI', see [CTRLC - Master SPI mode](#) for the correct description.

Bit	7	6	5	4	3	2	1	0
	CMODE[1:0]		PMODE[1:0]		SBMODE	CHSIZE[2:0]		
Access	R/W	R/W	R/W	R/W	R/W	R/W	R/W	R/W
Reset	0	0	0	0	0	0	1	1

**Bits 7:6 – CMODE[1:0]** USART Communication Mode

These bits select the communication mode of the USART.

Writing a 0x03 to these bits alters the available bit fields in this register, see [CTRLC - Master SPI mode](#).

Value	Name	Description
0x00	ASYNCHRONOUS	Asynchronous USART
0x01	SYNCHRONOUS	Synchronous USART
0x02	IRCOM	Infrared Communication
0x03	MSPI	Master SPI

**Bits 5:4 – PMODE[1:0]** Parity Mode

These bits enable and select the type of parity generation. See section [25.3.4.1 Parity](#) for more information.

Value	Name	Description
0x0	DISABLED	Disabled
0x1	-	Reserved
0x2	EVEN	Enabled, even parity
0x3	ODD	Enabled, odd parity

**Bit 3 – SBMODE** Stop Bit Mode

This bit selects the number of Stop bits to be inserted by the transmitter.

The receiver ignores this setting.

Value	Description
0	1 Stop bit
1	2 Stop bits

**Bits 2:0 – CHSIZE[2:0]** Character Size

These bits select the number of data bits in a frame. The receiver and transmitter use the same setting. For 9BIT character size, the order of which byte to read or write first, low or high byte of RXDATA or TXDATA, can be configured.

Value	Name	Description
0x00	5BIT	5-bit
0x01	6BIT	6-bit
0x02	7BIT	7-bit
0x03	8BIT	8-bit
0x04	-	Reserved
0x05	-	Reserved
0x06	9BITL	9-bit (Low byte first)
0x07	9BITH	9-bit (High byte first)

### 25.5.9 Control C - Master SPI Mode

**Name:** CTRLC  
**Offset:** 0x07  
**Reset:** 0x00  
**Property:** -

This register description is valid only when the USART is in Master SPI mode (CMODE written to MSPI). For other CMODE values, see [CTRLC - Normal Mode](#).

See [25.3.3.1.3 USART in Master SPI Mode](#) for a full description of the Master SPI mode operation.

Bit	7	6	5	4	3	2	1	0
	CMODE[1:0]					UDORD	UCPHA	
Access	R/W	R/W				R/W	R/W	
Reset	0	0				0	0	

#### Bits 7:6 – CMODE[1:0] USART Communication Mode

These bits select the communication mode of the USART.

Writing a value different than 0x03 to these bits alters the available bit fields in this register, see [CTRLC - Normal Mode](#).

Value	Name	Description
0x00	ASYNCHRONOUS	Asynchronous USART
0x01	SYNCHRONOUS	Synchronous USART
0x02	IRCOM	Infrared Communication
0x03	MSPI	Master SPI

#### Bit 2 – UDORD USART Data Order

This bit controls the frame format. The receiver and transmitter use the same setting. Changing the setting of the UDORD bit will corrupt all ongoing communication for both the receiver and the transmitter.

Value	Description
0	MSb of the data word is transmitted first
1	LSb of the data word is transmitted first

#### Bit 1 – UCPHA USART Clock Phase

This bit controls the phase of the interface clock. Refer to section [Clock Generation](#) for more information.

Value	Description
0	Data are sampled on the leading (first) edge
1	Data are sampled on the trailing (last) edge



### 25.5.10 Baud Register

**Name:** BAUD  
**Offset:** 0x08  
**Reset:** 0x00  
**Property:** -

The USARTn.BAUDL and USARTn.BAUDH register pair represents the 16-bit value, USARTn.BAUD. The low byte [7:0] (suffix L) is accessible at the original offset. The high byte [15:8] (suffix H) can be accessed at offset + 0x01.

Ongoing transmissions of the transmitter and receiver will be corrupted if the baud rate is changed. Writing to this register will trigger an immediate update of the baud rate prescaler. For more information on how to set the baud rate, see [Table 25-1, Equations for Calculating Baud Rate Register Setting](#).

Bit	15	14	13	12	11	10	9	8
	BAUD[15:8]							
Access	R/W	R/W	R/W	R/W	R/W	R/W	R/W	R/W
Reset	0	0	0	0	0	0	0	0
Bit	7	6	5	4	3	2	1	0
	BAUD[7:0]							
Access	R/W	R/W	R/W	R/W	R/W	R/W	R/W	R/W
Reset	0	0	0	0	0	0	0	0

**Bits 15:8 – BAUD[15:8]** USART Baud Rate High Byte  
 These bits hold the MSB of the 16-bit Baud register.

**Bits 7:0 – BAUD[7:0]** USART Baud Rate Low Byte  
 These bits hold the LSB of the 16-bit Baud register.

## 25.5.11 Control D

**Name:** CTRLD  
**Offset:** 0x0A  
**Reset:** 0x00  
**Property:** -

Bit	7	6	5	4	3	2	1	0
	ABW[1:0]							
Access	R/W	R/W						
Reset	0	0						

**Bits 7:6 – ABW[1:0]** Auto-baud Window Size

These bits control the tolerance for the difference between the baud rates between the two synchronizing devices when using Lin Constrained Auto-baud mode. The tolerance is based on the number of baud samples between every two bits. When baud rates are identical, there should be 32 baud samples between each bit pair since each bit is sampled 16 times.

Value	Name	Description
0x00	WDW0	32±6 (18% tolerance)
0x01	WDW1	32±5 (15% tolerance)
0x02	WDW2	32±7 (21% tolerance)
0x03	WDW3	32±8 (25% tolerance)

**25.5.12 Debug Control Register**

**Name:** DBGCTRL  
**Offset:** 0x0B  
**Reset:** 0x00  
**Property:** -

Bit	7	6	5	4	3	2	1	0
								DBGRUN
Access								R/W
Reset								0

**Bit 0 – DBGRUN** Debug Run

Value	Description
0	The peripheral is halted in Break Debug mode and ignores events
1	The peripheral will continue to run in Break Debug mode when the CPU is halted

**25.5.13 IrDA Control Register**

**Name:** EVCTRL  
**Offset:** 0x0C  
**Reset:** 0x00  
**Property:** -

Bit	7	6	5	4	3	2	1	0
								IREI
Access								R/W
Reset								0

**Bit 0 – IREI** IrDA Event Input Enable

This bit controls whether the IrDA event input is enabled or not. See section [25.3.3.2.7 IRCOM Mode of Operation](#) for more information.

Value	Description
0	IrDA Event input is enabled
1	IrDA Event input is disabled

**25.5.14 IRCOM Transmitter Pulse Length Control Register**

**Name:** TXPLCTRL  
**Offset:** 0x0D  
**Reset:** 0x00  
**Property:** -

Bit	7	6	5	4	3	2	1	0
	TXPL[7:0]							
Access	R/W	R/W	R/W	R/W	R/W	R/W	R/W	R/W
Reset	0	0	0	0	0	0	0	0

**Bits 7:0 – TXPL[7:0] Transmitter Pulse Length**

This 8-bit value sets the pulse modulation scheme for the transmitter. Setting this register will have effect only if IRCOM mode is selected by the USART, and it must be configured before the USART transmitter is enabled (TXEN).

Value	Description
0x00	3/16 of the baud rate period pulse modulation is used
0x01 – 0xFE	Fixed pulse length coding is used. The 8-bit value sets the number of peripheral clock periods for the pulse. The start of the pulse will be synchronized with the rising edge of the baud rate clock.
0xFF	Pulse coding disabled. RX and TX signals pass through the IRCOM module unaltered. This enables other features through the IRCOM module, such as half-duplex USART, loop-back testing, and USART RX input from an event channel.

**25.5.15 IRCOM Receiver Pulse Length Control Register**

**Name:** RXPLCTRL  
**Offset:** 0x0E  
**Reset:** 0x00  
**Property:** -

Bit	7	6	5	4	3	2	1	0
		RXPL[6:0]						
Access		R/W	R/W	R/W	R/W	R/W	R/W	R/W
Reset		0	0	0	0	0	0	0

**Bits 6:0 – RXPL[6:0]** Receiver Pulse Length

This 7-bit value sets the filter coefficient for the IRCOM transceiver. Setting this register will only have effect if IRCOM mode is selected by a USART, and it must be configured before the USART receiver is enabled (RXEN).

Value	Description
0x00	Filtering disabled
0x01– 0x7F	Filtering enabled. The value of RXPL+1 represents the number of samples required for a received pulse to be accepted.

## 26. SPI - Serial Peripheral Interface

### 26.1 Features

- Full Duplex, Three-Wire Synchronous Data Transfer
- Master or Slave Operation
- LSb First or MSb First Data Transfer
- Seven Programmable Bit Rates
- End of Transmission Interrupt Flag
- Write Collision Flag Protection
- Wake-up from Idle Mode
- Double-Speed (CK/2) Master SPI Mode

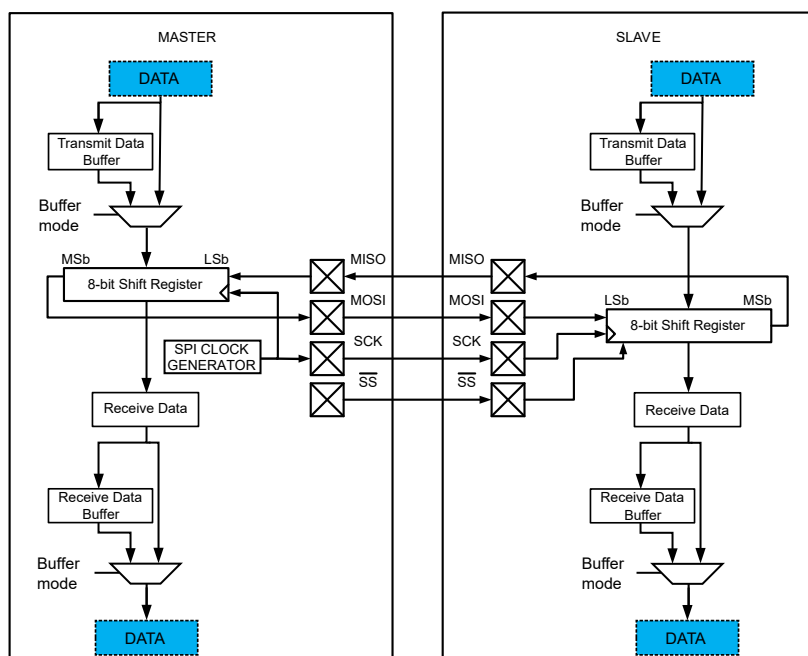
### 26.2 Overview

The Serial Peripheral Interface (SPI) is a high-speed synchronous data transfer interface using three or four pins. It allows full duplex communication between an AVR® device and peripheral devices, or between several microcontrollers. The SPI peripheral can be configured as either master or slave. The master initiates and controls all data transactions.

The interconnection between master and slave devices with SPI is shown in the block diagram. The system consists of two shift registers and a master clock generator. The SPI master initiates the communication cycle by pulling the desired slave's Slave Select (SS) signal low. The master and slave prepare the data to be sent to their respective shift registers, and the master generates the required clock pulses on the SCK line to exchange data. Data are always shifted from master to slave on the master output, slave input (MOSI) line, and from slave to master on the master input, slave output (MISO) line.

#### 26.2.1 Block Diagram

Figure 26-1. SPI Block Diagram



The SPI is built around an 8-bit shift register that will shift data out and in at the same time. The Transmit Data register and the Receive Data register are not physical registers but are mapped to other registers when written or

read: Writing the Transmit Data (SPIn.DATA) register will write the shift register in Normal mode and the Transmit Buffer register in Buffer mode. Reading the Receive Data (SPIn.DATA) register will read the Receive Data register in Normal mode and the Receive Data Buffer in Buffer mode.

In Master mode, the SPI has a clock generator to generate the SCK clock. In Slave mode, the received SCK clock is synchronized and sampled to trigger the shifting of data in the shift register.

### 26.2.2 Signal Description

**Table 26-1. Signals in Master and Slave Mode**

Signal	Description	Pin Configuration	
		Master Mode	Slave Mode
MOSI	Master Out Slave In	User defined <sup>(1)</sup>	Input
MISO	Master In Slave Out	Input	User defined <sup>(1,2)</sup>
SCK	Serial Clock	User defined <sup>(1)</sup>	Input
$\overline{SS}$	Slave Select	User defined <sup>(1)</sup>	Input

**Notes:**

1. If the pin data direction is configured as output, the pin level is controlled by the SPI.
2. If the SPI is in Slave mode and the MISO pin data direction is configured as output, the  $\overline{SS}$  pin controls the MISO pin output in the following way:
  - If the  $\overline{SS}$  pin is driven low, the MISO pin is controlled by the SPI.
  - If the  $\overline{SS}$  pin is driven high, the MISO pin is tri-stated.

When the SPI module is enabled, the pin data direction for the signals marked with “Input” in [Table 26-1](#) is overridden.

## 26.3 Functional Description

### 26.3.1 Initialization

Initialize the SPI to a basic functional state by following these steps:

1. Configure the  $\overline{SS}$  pin in the port peripheral.
2. Select the SPI master/slave operation by writing the Master/Slave Select (MASTER) bit in the Control A (SPIn.CTRLA) register.
3. In Master mode, select the clock speed by writing the Prescaler (PRESC) bits and the Clock Double (CLK2X) bit in SPIn.CTRLA.
4. Optional: Select the Data Transfer mode by writing to the MODE bits in the Control B (SPIn.CTRLB) register.
5. Optional: Write the Data Order (DORD) bit in SPIn.CTRLA.
6. Optional: Set up the Buffer mode by writing the BUFEN and BUFWR bits in the Control B (SPIn.CTRLB) register.
7. Optional: To disable the multi-master support in Master mode, write ‘1’ to the Slave Select Disable (SSD) bit in SPIn.CTRLB.
8. Enable the SPI by writing a ‘1’ to the ENABLE bit in SPIn.CTRLA.

### 26.3.2 Operation

#### 26.3.2.1 Master Mode Operation

When the SPI is configured in Master mode, a write to the SPIn.DATA register will start a new transfer. The SPI master can operate in two modes, Normal and Buffer, as explained below.

##### 26.3.2.1.1 Normal Mode

In Normal mode, the system is single-buffered in the transmit direction and double-buffered in the receive direction. This influences the data handling in the following ways:



1. New bytes to be sent cannot be written to the DATA (SPIn.DATA) register before the entire transfer has completed. A premature write will cause corruption of the transmitted data and the Write Collision (WRCOL) flag in SPIn.INTFLAGS will be set.
2. Received bytes are written to the Receive Data Buffer register immediately after the transmission is completed.
3. The Receive Data Buffer register has to be read before the next transmission is completed, or the data will be lost. This register is read by reading SPIn.DATA.
4. The Transmit Data Buffer and Receive Data Buffer registers are not used in Normal mode.

After a transfer has completed, the Interrupt Flag (IF) will be set in the Interrupt Flags (SPIn.INTFLAGS) register. This will cause the corresponding interrupt to be executed if this interrupt and the global interrupts are enabled. Setting the Interrupt Enable (IE) bit in the Interrupt Control (SPIn.INTCTRL) register will enable the interrupt.

### 26.3.2.1.2 Buffer Mode

The Buffer mode is enabled by writing the BUFEN bit in the SPIn.CTRLB register to '1'. The BUFWR bit in SPIn.CTRLB has no effect in Master mode. In Buffer mode, the system is double-buffered in the transmit direction and triple-buffered in the receive direction. This influences the data handling the following ways:

1. New bytes can be written to the DATA (SPIn.DATA) register as long as the Data Register Empty Interrupt Flag (DREIF) in the Interrupt Flag (SPIn.INTFLAGS) register is set. The first write will be transmitted right away, and the following write will go to the Transmit Data Buffer register.
2. A received byte is placed in a two-entry Receive First-In, First-Out (RX FIFO) queue comprised of the Receive Data register and Receive Data Buffer immediately after the transmission is completed.
3. The DATA register is used to read from the RX FIFO. The RX FIFO must be read at least every second transfer to avoid any loss of data.

When both the shift register and the Transmit Data Buffer register become empty, the Transfer Complete Interrupt Flag (TXCIF) in the Interrupt Flags (SPIn.INTFLAGS) register will be set. This will cause the corresponding interrupt to be executed if this interrupt and the global interrupts are enabled. Setting the Transfer Complete Interrupt Enable (TXCIE) in the Interrupt Control (SPIn.INTCTRL) register enables the Transfer Complete Interrupt.

### 26.3.2.1.3 $\overline{SS}$ Pin Functionality in Master Mode - Multi-Master Support

In Master mode, the Slave Select Disable (SSD) bit in the Control B (SPIn.CTRLB) register controls how the SPI uses the  $\overline{SS}$  pin.

- If SSD in SPIn.CTRLB is '0', the SPI can use the  $\overline{SS}$  pin to transition from Master to Slave mode. This allows multiple SPI masters on the same SPI bus.
- If SSD in SPIn.CTRLB is '0', and the  $\overline{SS}$  pin is configured as an output pin, it can be used as a regular I/O pin or by other peripheral modules, and will not affect the SPI system.
- If SSD in SPIn.CTRLB is '1', the SPI does not use the  $\overline{SS}$  pin. It can be used as a regular I/O pin, or by other peripheral modules.

If the SSD bit in SPIn.CTRLB is '0', and the  $\overline{SS}$  is configured as an input pin, the  $\overline{SS}$  pin must be held high to ensure Master SPI operation. A low level will be interpreted as another Master is trying to take control of the bus. This will switch the SPI into Slave mode, and the hardware of the SPI will perform the following actions:

1. The Master (MASTER) bit in the SPI Control A (SPIn.CTRLA) register is cleared, and the SPI system becomes a slave. The direction of the SPI pins will be switched when the conditions in [Table 26-2](#) are met.
2. The Interrupt Flag (IF) bit in the Interrupt Flags (SPIn.INTFLAGS) register will be set. If the interrupt is enabled and the global interrupts are enabled, the interrupt routine will be executed.

**Table 26-2. Overview of the  $\overline{SS}$  Pin Functionality when the SSD Bit in SPIn.CTRLB is '0'**

$\overline{SS}$ Configuration	$\overline{SS}$ Pin-Level	Description
Input	High	Master activated (selected)
	Low	Master deactivated, switched to Slave mode
Output	High	Master activated (selected)
	Low	

**Note:** If the device is in Master mode and it cannot be ensured that the  $\overline{SS}$  pin will stay high between two transmissions, the status of the Master (MASTER) bit in SPIn.CTRLA has to be checked before a new byte is written. After the Master bit has been cleared by a low level on the  $\overline{SS}$  line, it must be set by the application to re-enable the SPI Master mode.

### 26.3.2.2 Slave Mode

In Slave mode, the SPI peripheral receives SPI clock and Slave Select from a Master. Slave mode supports three operational modes: One Normal mode and two configurations for the Buffered mode. In Slave mode, the control logic will sample the incoming signal on the SCK pin. To ensure correct sampling of this clock signal, the minimum low and high periods must each be longer than two peripheral clock cycles.

#### 26.3.2.2.1 Normal Mode

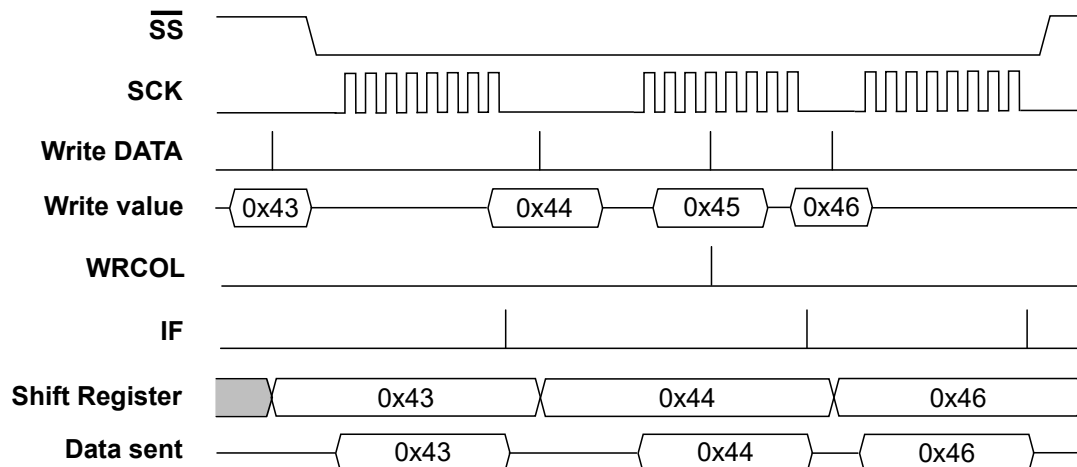
In Normal mode, the SPI peripheral will remain Idle as long as the  $\overline{SS}$  pin is driven high. In this state, the software may update the contents of the DATA register, but the data will not be shifted out by incoming clock pulses on the SCK pin until the  $\overline{SS}$  pin is driven low. If the  $\overline{SS}$  pin is driven low, the slave will start to shift out data on the first SCK clock pulse. When one byte has been completely shifted, the SPI Interrupt Flag (IF) in SPIn.INTFLAGS is set.

The user application may continue placing new data to be sent into the DATA register before reading the incoming data. New bytes to be sent cannot be written to the DATA register before the entire transfer has completed. A premature write will be ignored, and the hardware will set the Write Collision (WRCOL) flag in SPIn.INTFLAGS.

When the  $\overline{SS}$  pin is driven high, the SPI logic is halted, and the SPI slave will not receive any new data. Any partially received packet in the shift register will be lost.

Figure 26-2 shows a transmission sequence in Normal mode. Notice how the value 0x45 is written to the DATA register but never transmitted.

**Figure 26-2. SPI Timing Diagram in Normal Mode (Buffer Mode Not Enabled)**



The figure above shows three transfers and one write to the DATA register while the SPI is busy with a transfer. This write will be ignored, and the Write Collision (WRCOL) flag in SPIn.INTFLAGS is set.

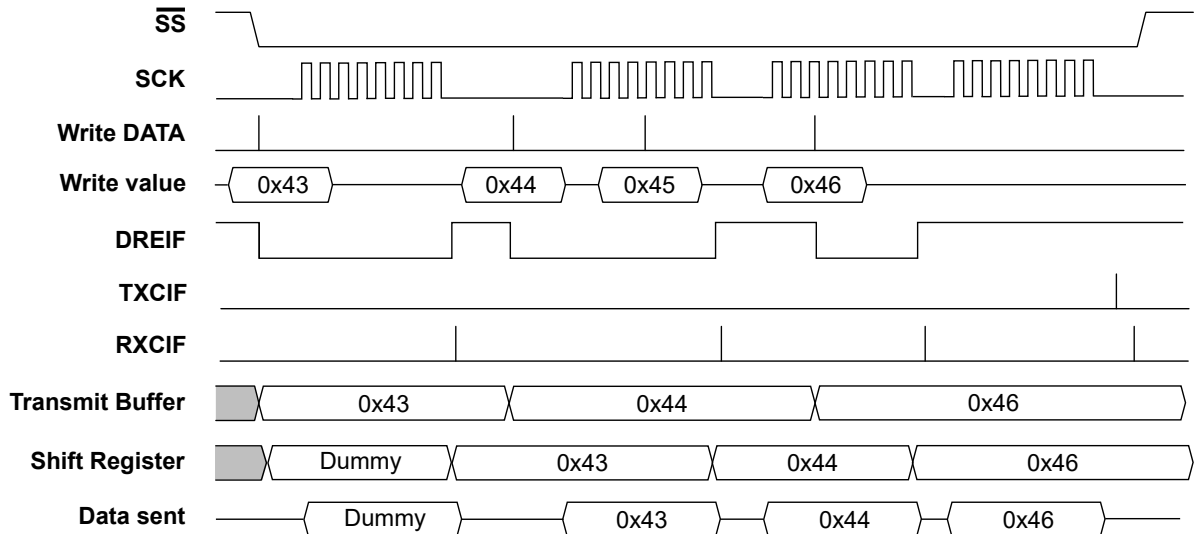
#### 26.3.2.2.2 Buffer Mode

To avoid data collisions, the SPI peripheral can be configured in Buffered mode by writing a '1' to the Buffer Mode Enable (BUFEN) bit in the Control B (SPIn.CTRLB) register. In this mode, the SPI has additional interrupt flags and extra buffers. The extra buffers are shown in Figure 26-1. There are two different modes for the Buffer mode, selected with the Buffer mode Wait for Receive (BUFWR) bit. The two different modes are described below with timing diagrams.

##### Slave Buffer Mode with Wait for Receive Bit Written to '0'

In Slave mode, if the Buffer mode Wait for Receive (BUFWR) bit in SPIn.CTRLB is written to '0', a dummy byte will be sent before the transmission of user data starts. Figure 26-3 shows a transmission sequence with this configuration. Notice how the value 0x45 is written to the Data (SPIn.DATA) register but never transmitted.

Figure 26-3. SPI Timing Diagram in Buffer Mode with BUFWR in SPIn.CTRLB Written to '0'



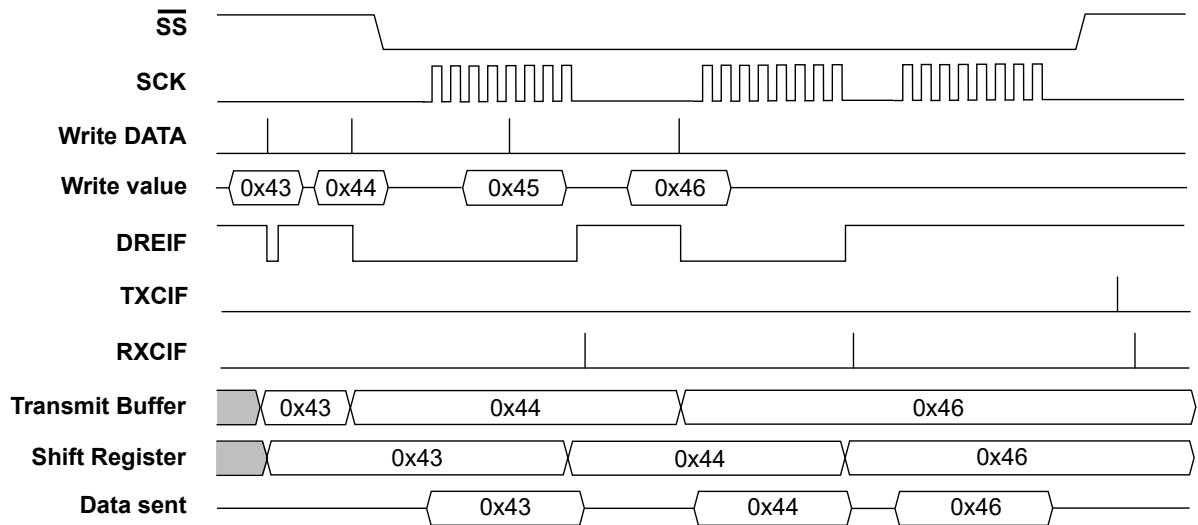
When the Wait for Receive (BUFWR) bit in SPIn.CTRLB is written to '0', all writes to the Data (SPIn.DATA) register go to the Transmit Data Buffer register. The figure above shows that the value 0x43 is written to the Data (SPIn.DATA) register, but it is not immediately transferred to the shift register, so the first byte sent will be a dummy byte. The value of the dummy byte equals the values that were in the shift register at the time. After the first dummy transfer is completed, the value 0x43 is transferred to the shift register. Then 0x44 is written to the Data (SPIn.DATA) register and goes to the Transmit Data Buffer register. A new transfer is started, and 0x43 will be sent. The value 0x45 is written to the Data (SPIn.DATA) register, but the Transmit Data Buffer register is not updated since it is already full containing 0x44 and the Data Register Empty Interrupt Flag (DREIF) in SPIn.INTFLAGS is low. The value 0x45 will be lost. After the transfer, the value 0x44 is moved to the shift register. During the next transfer, 0x46 is written to the Data (SPIn.DATA) register, and 0x44 is sent out. After the transfer is complete, 0x46 is copied into the shift register and sent out in the next transfer.

The DREIF goes low every time the Transmit Data Buffer register is written and goes high after a transfer when the previous value in the Transmit Data Buffer register is copied into the shift register. The Receive Complete Interrupt Flag (RXCIF) in SPIn.INTFLAGS is set one cycle after the DREIF goes high. The Transfer Complete Interrupt Flag is set one cycle after the Receive Complete Interrupt Flag is set when both the value in the shift register and the Transmit Data Buffer register have been sent.

#### Slave Buffer Mode with Wait for Receive Bit Written to '1'

In Slave mode, if the Buffer mode Wait for Receive (BUFWR) bit in SPIn.CTRLB is written to '1', the transmission of user data starts as soon as the  $\overline{SS}$  pin is driven low. [Figure 26-4](#) shows a transmission sequence with this configuration. Notice how the value 0x45 is written to the Data (SPIn.DATA) register but never transmitted.

Figure 26-4. SPI Timing Diagram in Buffer Mode with CTRLB.BUFWR Written to '1'



All writes to the Data (SPIn.DATA) register go to the Transmit Data Buffer register. The figure above shows that the value 0x43 is written to the Data (SPIn.DATA) register, and since the  $\overline{SS}$  pin is high, it is copied to the shift register in the next cycle. Then the next write (0x44) will go to the Transmit Data Buffer register. During the first transfer, the value 0x43 will be shifted out. In the figure above, the value 0x45 is written to the Data (SPIn.DATA) register, but the Transmit Data Buffer register is not updated since the DREIF is low. After the transfer is completed, the value 0x44 from the Transmit Data Buffer register is copied to the shift register. The value 0x46 is written to the Transmit Data Buffer register. During the next two transfers, 0x44 and 0x46 are shifted out. The flags behave identically to the Buffer Mode Wait for Receive (BUFWR) bit in SPIn.CTRLB set to '0'.

### 26.3.2.2.3 $\overline{SS}$ Pin Functionality in Slave Mode

The Slave Select ( $\overline{SS}$ ) pin plays a central role in the operation of the SPI. Depending on the mode the SPI is in, and the configuration of this pin, it can be used to activate or deactivate devices. The  $\overline{SS}$  pin is used as a Chip Select pin.

In Slave mode,  $\overline{SS}$ , MOSI, and SCK are always inputs. The behavior of the MISO pin depends on the configured data direction of the pin in the port peripheral and the value of  $\overline{SS}$ . When the  $\overline{SS}$  pin is driven low, the SPI is activated and will respond to received SCK pulses by clocking data out on MISO, if the user has configured the data direction of the MISO pin as output. When the  $\overline{SS}$  pin is driven high, the SPI is deactivated, meaning that it will not receive incoming data. If the MISO pin data direction is configured as output, the MISO pin will be tri-stated. Table 26-3 shows an overview of the  $\overline{SS}$  pin functionality.

Table 26-3. Overview of the  $\overline{SS}$  Pin Functionality

$\overline{SS}$ Configuration	$\overline{SS}$ Pin-Level	Description	MISO Pin Mode	
			Port Direction = Output	Port Direction = Input
Always Input	High	Slave deactivated (deselected)	Tri-stated	Input
	Low	Slave activated (selected)	Output	Input

**Note:** In Slave mode, the SPI state machine will be reset when the  $\overline{SS}$  pin is driven high. If the  $\overline{SS}$  pin is driven high during a transmission, the SPI will stop sending and receiving data immediately and both data received and data sent must be considered lost. As the  $\overline{SS}$  pin is used to signal the start and end of a transfer, it is useful for achieving packet/byte synchronization and keeping the Slave bit counter synchronized with the master clock generator.

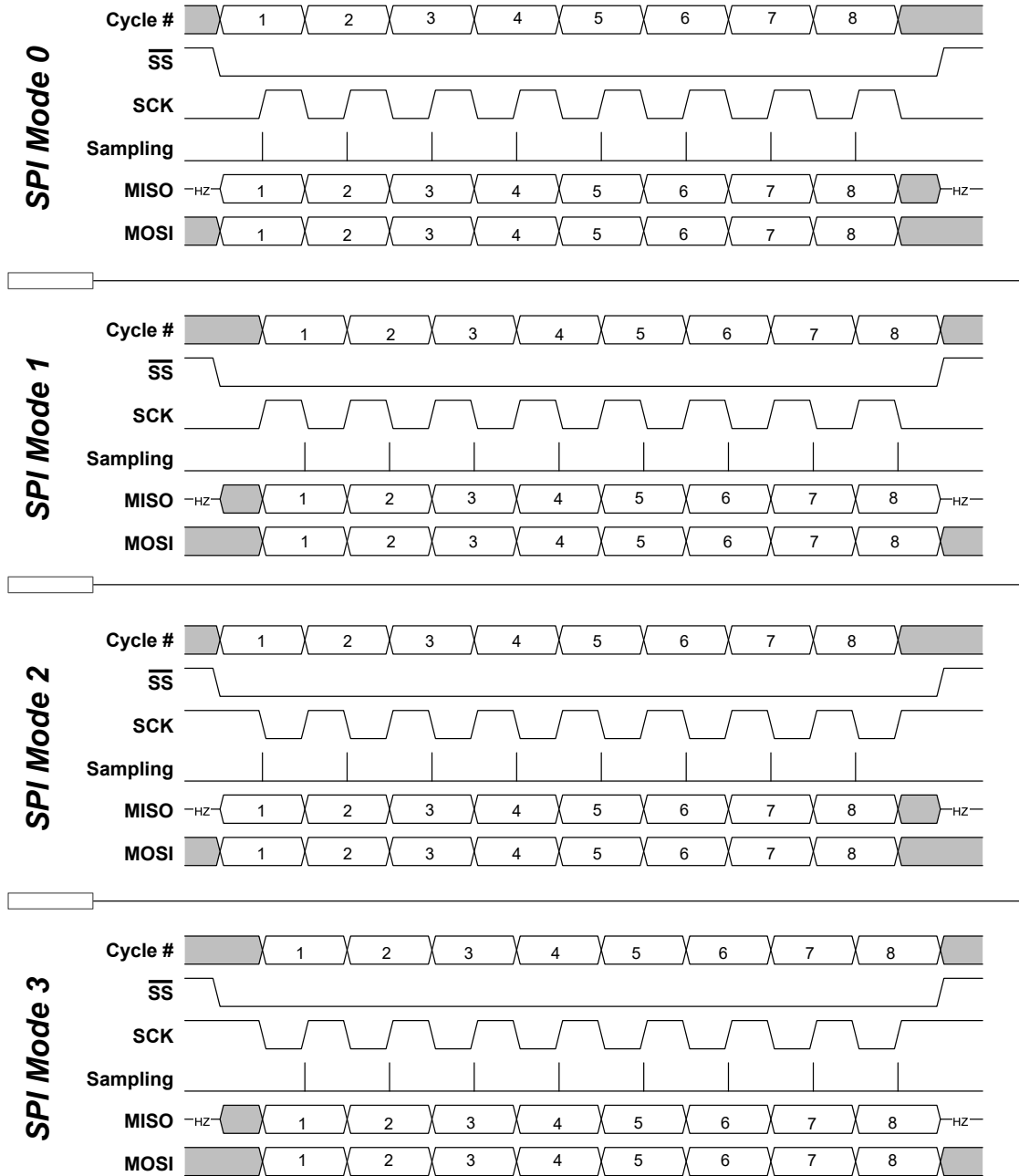
### 26.3.2.3 Data Modes

There are four combinations of SCK phase and polarity with respect to serial data. The desired combination is selected by writing to the MODE bits in the Control B (SPIn.CTRLB) register.

The SPI data transfer formats are shown below. Data bits are shifted out and latched in on opposite edges of the SCK signal, ensuring sufficient time for data signals to stabilize.

The leading edge is the first clock edge of a clock cycle. The trailing edge is the last clock edge of a clock cycle.

**Figure 26-5. SPI Data Transfer Modes**



### 26.3.2.4 Events

The SPI can generate the following events:

**Table 26-4. Event Generators in SPI**

Generator Name		Description	Event Type	Generating Clock Domain	Length of Event
Module	Event				
SPI <sub>in</sub>	SCK	SPI Master clock	Level	CLK_PER	Minimum two CLK_PER periods

The SPI has no event users.

Refer to the *Event System* section for more details regarding event types and Event System configuration.

### 26.3.2.5 Interrupts

**Table 26-5. Available Interrupt Vectors and Sources**

Name	Vector Description	Conditions	
		Normal Mode	Buffer Mode
SPI <sub>in</sub>	SPI interrupt	<ul style="list-style-type: none"> <li>• IF: Interrupt Flag interrupt</li> <li>• WRCOL: Write Collision interrupt</li> </ul>	<ul style="list-style-type: none"> <li>• SSI: Slave Select Trigger Interrupt</li> <li>• DRE: Data Register Empty interrupt</li> <li>• TXC: Transfer Complete interrupt</li> <li>• RXC: Receive Complete interrupt</li> </ul>

When an interrupt condition occurs, the corresponding interrupt flag is set in the peripheral's Interrupt Flags (*peripheral.INTFLAGS*) register.

An interrupt source is enabled or disabled by writing to the corresponding enable bit in the peripheral's Interrupt Control (*peripheral.INTCTRL*) register.

An interrupt request is generated when the corresponding interrupt source is enabled, and the interrupt flag is set. The interrupt request remains active until the interrupt flag is cleared. See the peripheral's INTFLAGS register for details on how to clear interrupt flags.

## 26.4 Register Summary

Offset	Name	Bit Pos.	7	6	5	4	3	2	1	0
0x00	<a href="#">CTRLA</a>	7:0		DORD	MASTER	CLK2X		PRESC[1:0]		ENABLE
0x01	<a href="#">CTRLB</a>	7:0	BUFEN	BUFWR				SSD	MODE[1:0]	
0x02	<a href="#">INTCTRL</a>	7:0	RXCIE	TXCIE	DREIE	SSIE				IE
0x03	<a href="#">INTFLAGS</a>	7:0	IF	WRCOL						
0x03	<a href="#">INTFLAGS</a>	7:0	RXCIF	TXCIF	DREIF	SSIF				BUFOVF
0x04	<a href="#">DATA</a>	7:0	DATA[7:0]							

## 26.5 Register Description

**26.5.1 Control A**

**Name:** CTRLA  
**Offset:** 0x00  
**Reset:** 0x00  
**Property:** -

	7	6	5	4	3	2	1	0
		DORD	MASTER	CLK2X		PRESC[1:0]		ENABLE
Access		R/W	R/W	R/W		R/W	R/W	R/W
Reset		0	0	0		0	0	0

**Bit 6 – DORD** Data Order

Value	Description
0	The MSb of the data word is transmitted first
1	The LSb of the data word is transmitted first

**Bit 5 – MASTER** Master/Slave Select

This bit selects the desired SPI mode.

If  $\overline{SS}$  is configured as input and driven low while this bit is '1', then this bit is cleared and the IF in SPIn.INTFLAGS is set. The user has to write MASTER = 1 again to re-enable SPI Master mode.

This behavior is controlled by the Slave Select Disable (SSD) bit in SPIn.CTRLB.

Value	Description
0	SPI Slave mode selected
1	SPI Master mode selected

**Bit 4 – CLK2X** Clock Double

When this bit is written to '1' the SPI speed (SCK frequency, after internal prescaler) is doubled in Master mode.

Value	Description
0	SPI speed (SCK frequency) is not doubled
1	SPI speed (SCK frequency) is doubled in Master mode

**Bits 2:1 – PRESC[1:0]** Prescaler

This bit field controls the SPI clock rate configured in Master mode. These bits have no effect in Slave mode. The relationship between SCK and the peripheral clock frequency ( $f_{CLK\_PER}$ ) is shown below.

The output of the SPI prescaler can be doubled by writing the CLK2X bit to '1'.

Value	Name	Description
0x0	DIV4	CLK_PER/4
0x1	DIV16	CLK_PER/16
0x2	DIV64	CLK_PER/64
0x3	DIV128	CLK_PER/128

**Bit 0 – ENABLE** SPI Enable

Value	Description
0	SPI is disabled
1	SPI is enabled



### 26.5.2 Control B

**Name:** CTRLB  
**Offset:** 0x01  
**Reset:** 0x00  
**Property:** -

	Bit	7	6	5	4	3	2	1	0
		BUFEN	BUFWR				SSD	MODE[1:0]	
Access		R/W	R/W				R/W	R/W	R/W
Reset		0	0				0	0	0

**Bit 7 – BUFEN** Buffer Mode Enable

Writing this bit to '1' enables Buffer mode. This will enable two receive buffers and one transmit buffer. Both will have separate interrupt flags, transmit complete and receive complete.

**Bit 6 – BUFWR** Buffer Mode Wait for Receive

When writing this bit to '0' the first data transferred will be a dummy sample.

Value	Description
0	One SPI transfer must be completed before the data are copied into the shift register
1	If writing to the Data register when the SPI is enabled and $\overline{SS}$ is high, the first write will go directly to the shift register

**Bit 2 – SSD** Slave Select Disable

If this bit is set when operating as SPI Master (MASTER = 1 in SPIn.CTRLA),  $\overline{SS}$  does not disable Master mode.

Value	Description
0	Enable the Slave Select line when operating as SPI master
1	Disable the Slave Select line when operating as SPI master

**Bits 1:0 – MODE[1:0]** Mode

These bits select the Transfer mode. The four combinations of SCK phase and polarity with respect to the serial data are shown below. These bits decide whether the first edge of a clock cycle (leading edge) is rising or falling and whether data setup and sample occur on the leading or trailing edge. When the leading edge is rising, the SCK signal is low when idle, and when the leading edge is falling, the SCK signal is high when idle.

Value	Name	Description
0x0	0	Leading edge: Rising, sample Trailing edge: Falling, setup
0x1	1	Leading edge: Rising, setup Trailing edge: Falling, sample
0x2	2	Leading edge: Falling, sample Trailing edge: Rising, setup
0x3	3	Leading edge: Falling, setup Trailing edge: Rising, sample

### 26.5.3 Interrupt Control

**Name:** INTCTRL  
**Offset:** 0x02  
**Reset:** 0x00  
**Property:** -

	7	6	5	4	3	2	1	0
	RXCIE	TXCIE	DREIE	SSIE				IE
Access	R/W	R/W	R/W	R/W				R/W
Reset	0	0	0	0				0

**Bit 7 – RXCIE** Receive Complete Interrupt Enable  
 In Buffer mode, this bit enables the Receive Complete interrupt. The enabled interrupt will be triggered when the RXCIF in the SPIn.INTFLAGS register is set. In the Non-Buffer mode, this bit is '0'.

**Bit 6 – TXCIE** Transfer Complete Interrupt Enable  
 In Buffer mode, this bit enables the Transfer Complete interrupt. The enabled interrupt will be triggered when the TXCIF in the SPIn.INTFLAGS register is set. In the Non-Buffer mode, this bit is '0'.

**Bit 5 – DREIE** Data Register Empty Interrupt Enable  
 In Buffer mode, this bit enables the Data Register Empty interrupt. The enabled interrupt will be triggered when the DREIF in the SPIn.INTFLAGS register is set. In the Non-Buffer mode, this bit is '0'.

**Bit 4 – SSIE** Slave Select Trigger Interrupt Enable  
 In Buffer mode, this bit enables the Slave Select interrupt. The enabled interrupt will be triggered when the SSIF in the SPIn.INTFLAGS register is set. In the Non-Buffer mode, this bit is '0'.

**Bit 0 – IE** Interrupt Enable  
 This bit enables the SPI interrupt when the SPI is not in Buffer mode. The enabled interrupt will be triggered when RXCIF/IF is set in the SPIn.INTFLAGS register.

**26.5.4 Interrupt Flags - Normal Mode**

**Name:** INTFLAGS  
**Offset:** 0x03  
**Reset:** 0x00  
**Property:** -

	7	6	5	4	3	2	1	0
	IF	WRCOL						
Access	R/W	R/W						
Reset	0	0						

**Bit 7 – IF** Interrupt Flag

This flag is set when a serial transfer is complete, and one byte is completely shifted in/out of the SPIn.DATA register. If  $\overline{SS}$  is configured as input and is driven low when the SPI is in Master mode, this will also set this flag. The IF is cleared by hardware when executing the corresponding interrupt vector. Alternatively, the IF can be cleared by first reading the SPIn.INTFLAGS register when IF is set, and then accessing the SPIn.DATA register.

**Bit 6 – WRCOL** Write Collision

The WRCOL flag is set if the SPIn.DATA register is written before a complete byte has been shifted out. This flag is cleared by first reading the SPIn.INTFLAGS register when WRCOL is set, and then accessing the SPIn.DATA register.

### 26.5.5 Interrupt Flags - Buffer Mode

**Name:** INTFLAGS  
**Offset:** 0x03  
**Reset:** 0x00  
**Property:** -

	7	6	5	4	3	2	1	0
	RXCIF	TXCIF	DREIF	SSIF				BUFOVF
Access	R/W	R/W	R/W	R/W				R/W
Reset	0	0	0	0				0

**Bit 7 – RXCIF** Receive Complete Interrupt Flag

This flag is set when there are unread data in the Receive Data Buffer register and cleared when the Receive Data Buffer register is empty (that is, it does not contain any unread data).  
 When interrupt-driven data reception is used, the Receive Complete Interrupt routine must read the received data from the DATA register in order to clear RXCIF. If not, a new interrupt will occur directly after the return from the current interrupt. This flag can also be cleared by writing a '1' to its bit location.

**Bit 6 – TXCIF** Transfer Complete Interrupt Flag

This flag is set when all the data in the Transmit shift register has been shifted out, and there is no new data in the transmit buffer (SPIn.DATA). The flag is cleared by writing a '1' to its bit location.

**Bit 5 – DREIF** Data Register Empty Interrupt Flag

This flag indicates whether the Transmit Data Buffer register is ready to receive new data. The flag is '1' when the transmit buffer is empty and '0' when the transmit buffer contains data to be transmitted that has not yet been moved into the shift register. The DREIF is cleared after a Reset to indicate that the transmitter is ready.  
 The DREIF is cleared by writing to DATA. When interrupt-driven data transmission is used, the Data Register Empty Interrupt routine must either write new data to DATA in order to clear DREIF or disable the Data Register Empty interrupt. If not, a new interrupt will occur directly after the return from the current interrupt.

**Bit 4 – SSIF** Slave Select Trigger Interrupt Flag

This flag indicates that the SPI has been in Master mode and the  $\overline{SS}$  pin has been pulled low externally, so the SPI is now working in Slave mode. The flag will only be set if the Slave Select Disable (SSD) bit is not '1'. The flag is cleared by writing a '1' to its bit location.

**Bit 0 – BUFOVF** Buffer Overflow

This flag indicates data loss due to a Receive Data Buffer full condition. This flag is set if a Buffer Overflow condition is detected. A Buffer Overflow occurs when the receive buffer is full (two bytes), and a third byte has been received in the shift register. If there is no transmit data, the Buffer Overflow will not be set before the start of a new serial transfer. This flag is cleared when the DATA register is read, or by writing a '1' to its bit location.

**26.5.6 Data**

**Name:** DATA  
**Offset:** 0x04  
**Reset:** 0x00  
**Property:** -

	7	6	5	4	3	2	1	0
	DATA[7:0]							
Access	R/W	R/W	R/W	R/W	R/W	R/W	R/W	R/W
Reset	0	0	0	0	0	0	0	0

**Bits 7:0 – DATA[7:0] SPI Data**

The DATA register is used for sending and receiving data. Writing to the register initiates the data transmission when in Master mode, while preparing data for sending in Slave mode. The byte written to the register shifts out on the SPI output line when a transaction is initiated.

The SPIn.DATA register is not a physical register. Depending on what mode is configured, it is mapped to other registers as described below.

- Normal mode:
  - Writing the DATA register will write the shift register
  - Reading from DATA will read from the Receive Data register
- Buffer mode:
  - Writing the DATA register will write to the Transmit Data Buffer register.
  - Reading from DATA will read from the Receive Data Buffer register. The contents of the Receive Data register will then be moved to the Receive Data Buffer register.

## 27. TWI - Two-Wire Interface

### 27.1 Features

- Two-Wire Communication Interface
- Philips I<sup>2</sup>C Compatible
  - Standard mode
  - Fast mode
  - Fast mode Plus
- System Management Bus (SMBus) 2.0 Compatible
  - Support arbitration between Start/repeated Start and data bit
  - Slave arbitration allows support for the Address Resolution Protocol (ARP)
  - Configurable SMBus Layer 1 time-outs in hardware
  - Independent time-outs for Dual mode
- Independent Master and Slave Operation
  - Combined (same pins) or Dual mode (separate pins)
  - Single or multi-master bus operation with full arbitration support
- Hardware Support for Slave Address Match
  - Operates in all sleep modes
  - 7-bit address recognition
  - General call address recognition
  - Support for address range masking or secondary address match
- Input Filter for Bus Noise Suppression
- Smart Mode Support

### 27.2 Overview

The Two-Wire Interface (TWI) is a bidirectional, two-wire communication interface (bus) with a Serial Data Line (SDA) and a Serial Clock Line (SCL).

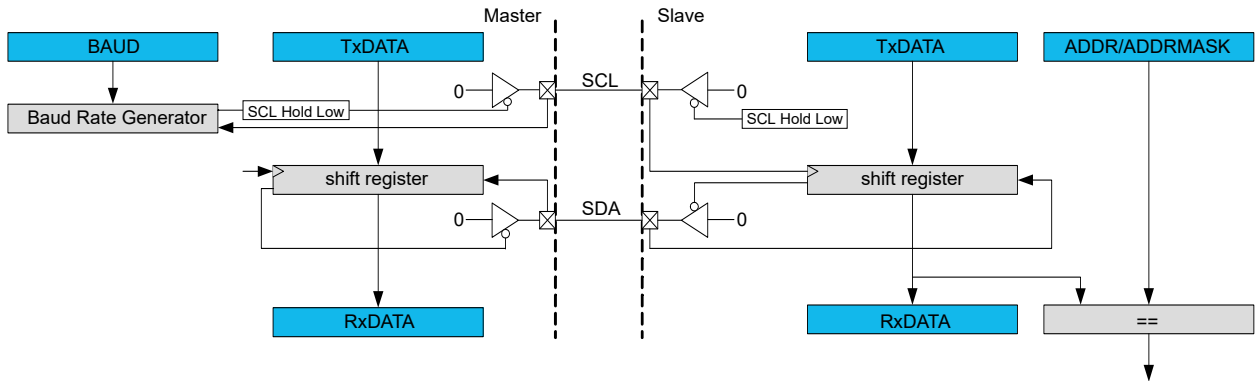
The TWI bus connects one or several slave devices to one or several master devices. Any device connected to the bus can act as a master, a slave, or both. The master generates the SCL by using a Baud Rate Generator (BRG) and initiates data transactions by addressing one slave and telling whether it wants to transmit or receive data. The BRG is capable of generating the Standard mode (Sm) and Fast mode (Fm, Fm+) bus frequencies from 100 kHz up to 1 MHz.

The TWI will detect Start and Stop conditions, bus collisions and bus errors. Arbitration lost, errors, collision, and clock hold are also detected and indicated in separate status flags available in both Master and Slave modes.

The TWI supports multi-master bus operation and arbitration. An arbitration scheme handles the case where more than one master tries to transmit data at the same time. The TWI also supports Smart mode, which can auto-trigger operations and thus reduce software complexity. The TWI supports Dual mode with simultaneous master and slave operations, which are implemented as independent units with separate enabling and configuration. The TWI supports Quick Command mode where the master can address a slave without exchanging data.

### 27.2.1 Block Diagram

Figure 27-1. TWI Block Diagram



### 27.2.2 Signal Description

Signal	Description	Type
SCL	Serial Clock Line	Digital I/O
SDA	Serial Data Line	Digital I/O

## 27.3 Functional Description

### 27.3.1 General TWI Bus Concepts

The TWI provides a simple, bidirectional, two-wire communication bus consisting of:

- Serial Data Line (SDA) for packet transfer
- Serial Clock Line (SCL) for the bus clock

The two lines are open-collector lines (wired-AND).

The TWI bus topology is a simple and efficient method of interconnecting multiple devices on a serial bus. A device connected to the bus can be a master or a slave. Only master devices can control the bus and the bus communication.

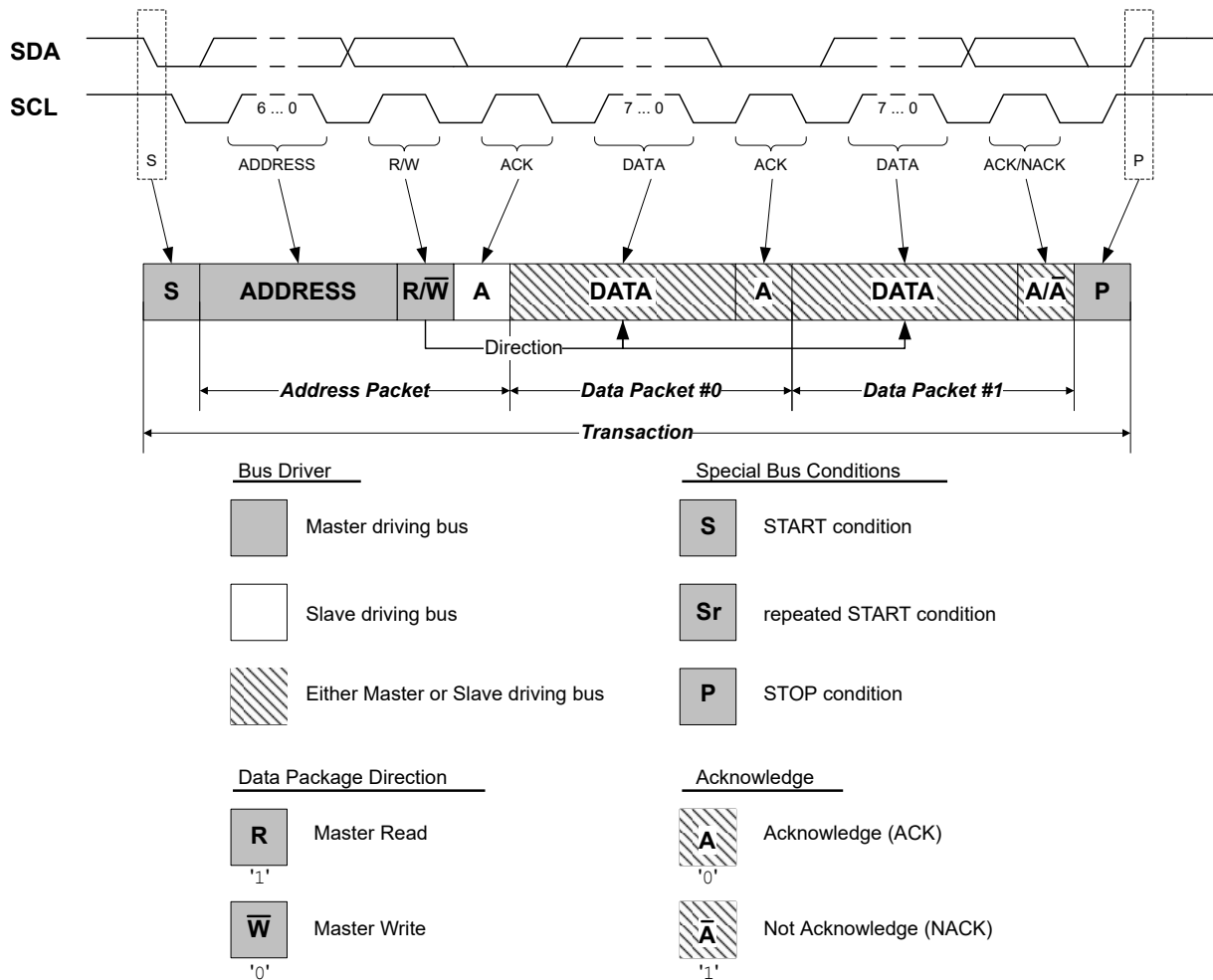
A unique address is assigned to each slave device connected to the bus, and the master will use it to control the slave and initiate a transaction. Several masters can be connected to the same bus. This is called a multi-master environment. An arbitration mechanism is provided for resolving bus ownership among masters, since only one master device may own the bus at any given time.

A master indicates the start of a transaction by issuing a Start condition (S) on the bus. The master provides the clock signal for the transaction. An address packet with a 7-bit slave address (ADDRESS) and a direction bit, representing whether the master wishes to read or write data (R/W), are then sent.

The addressed I<sup>2</sup>C slave will then acknowledge (ACK) the address, and data packet transactions can begin. Every 9-bit data packet consists of eight data bits followed by a 1-bit reply indicating whether the data was acknowledged or not by the receiver.

After all the data packets (DATA) are transferred, the master issues a Stop condition (P) on the bus to end the transaction.

Figure 27-2. Basic TWI Transaction Diagram Topology for a 7-bit Address Bus



## 27.3.2 TWI Basic Operation

### 27.3.2.1 Initialization

If used, the following bits must be configured before enabling the TWI device:

- The SDA Setup Time (SDASETUP) bit from the Control A (TWIn.CTRLA) register
- The SDA Hold Time (SDAHOLD) bit field from the Control A (TWIn.CTRLA) register
- The FM Plus Enable (FMPEN) bit from the Control A (TWIn.CTRLA) register

#### 27.3.2.1.1 Master Initialization

The Master Baud Rate (TWIn.MBAUD) register must be written to a value that will result in a valid TWI bus clock frequency. Writing a '1' to the Enable TWI Master (ENABLE) bit in the Master Control A (TWIn.MCTRLA) register will enable the TWI master. The Bus State (BUSSTATE) bit field from the Master Status (TWIn.MSTATUS) register must be set to 0x1, to force the bus state to Idle.

#### 27.3.2.1.2 Slave Initialization

The address of the slave must be written in the Slave Address (TWIn.SADDR) register. Writing a '1' to the Enable TWI Slave (ENABLE) bit in the Slave Control A (TWIn.SCTRLA) register will enable the TWI slave. The slave device will wait for a master device to issue a Start condition and the matching slave address.

### 27.3.2.2 TWI Master Operation

The TWI master is byte-oriented, with an optional interrupt after each byte. There are separate interrupt flags for the master write and read operation. Interrupt flags can also be used for polled operation. There are dedicated status flags for indicating ACK/NACK received, bus error, arbitration lost, clock hold, and bus state.



When an interrupt flag is set to '1', the SCL is forced low. This will give the master time to respond or handle any data, and will, in most cases, require software interaction. Clearing the interrupt flags releases the SCL. The number of interrupts generated is kept to a minimum by an automatic handling of most conditions.

### 27.3.2.2.1 Clock Generation

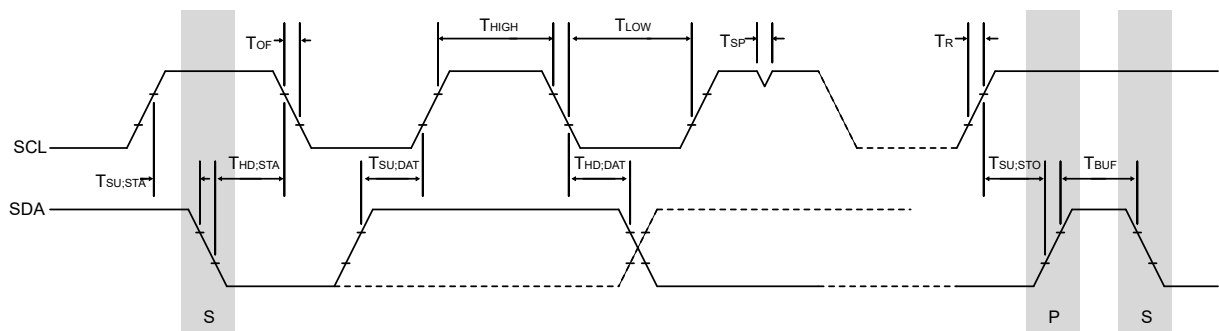
The TWI supports several transmission modes with different frequency limitations:

- Standard mode (Sm) up to 100 kHz
- Fast mode (Fm) up to 400 kHz
- Fast mode Plus (Fm+) up to 1 MHz

The Master Baud Rate (TWIn.MBAUD) register must be written to a value that will result in a TWI bus clock frequency equal to or less than those frequency limits, depending on the transmission mode.

The low ( $T_{LOW}$ ) and high ( $T_{HIGH}$ ) times are determined by the Master Baud Rate (TWIn.MBAUD) register, while the rise ( $T_R$ ) and fall ( $T_{OF}$ ) times are determined by the bus topology.

**Figure 27-3. SCL Timing**



- $T_{LOW}$  is the low period of SCL clock
- $T_{HIGH}$  is the high period of SCL clock
- $T_R$  is determined by the bus impedance; for internal pull-ups. Refer to *Electrical Characteristics* for details.
- $T_{OF}$  is the output fall time and is determined by the open-drain current limit and bus impedance. Refer to *Electrical Characteristics* for details.

### Properties of the SCL Clock

The SCL frequency is given by:

$$f_{SCL} = \frac{1}{T_{LOW} + T_{HIGH} + T_{OF} + T_R} [\text{Hz}]$$

The SCL clock is designed to have a 50/50 duty cycle, where the low period of the duty cycle comprises of  $T_{OF}$  and  $T_{LOW}$ .  $T_{HIGH}$  will not start until a high state of SCL has been detected. The BAUD bit field in the TWIn.MBAUD register and the SCL frequency are related by the following formula:

$$f_{SCL} = \frac{f_{CLK\_PER}}{10 + 2 \times BAUD + f_{CLK\_PER} \times T_R} \quad (1)$$

Equation 1 can be transformed to express BAUD:

$$BAUD = \frac{f_{CLK\_PER}}{2 \times f_{SCL}} - \left( 5 + \frac{f_{CLK\_PER} \times T_R}{2} \right) \quad (2)$$

### Calculation of the BAUD Value

To ensure operation within the specifications of the desired speed mode (Sm, Fm, Fm+), follow these steps:

1. Calculate a value for the BAUD bit field using equation 2
2. Calculate  $T_{LOW}$  using the BAUD value from step 1:

$$T_{LOW} = \frac{BAUD + 5}{f_{CLK\_PER}} - T_{OF} \quad (3)$$

- Check if your  $T_{LOW}$  from equation 3 is above the specified minimum of the desired mode ( $T_{LOW\_Sm} = 4700$  ns,  $T_{LOW\_Fm} = 1300$  ns,  $T_{LOW\_Fm+} = 500$  ns)
  - If the calculated  $T_{LOW}$  is above the limit, use the BAUD value from equation 2
  - If the limit is not met, calculate a new BAUD value using equation 4 below, where  $T_{LOW\_mode}$  is either  $T_{LOW\_Sm}$ ,  $T_{LOW\_Fm}$ , or  $T_{LOW\_Fm+}$  from the mode specifications:

$$BAUD = f_{CLK\_PER} \times (T_{LOW\_mode} + T_{OF}) - 5 \quad (4)$$

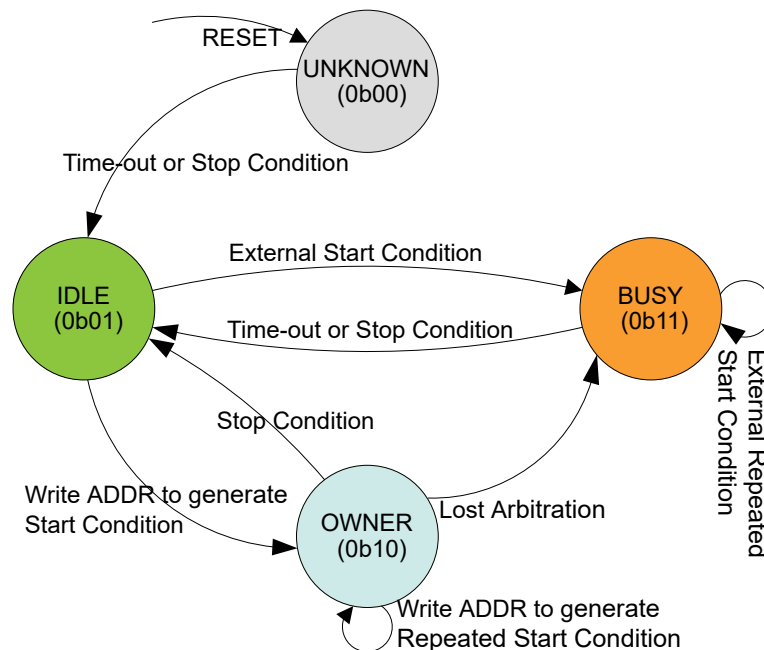
### 27.3.2.2.2 TWI Bus State Logic

The bus state logic continuously monitors the activity on the TWI bus when the master is enabled. It continues to operate in all sleep modes, including Power-Down.

The bus state logic includes Start and Stop condition detectors, collision detection, inactive bus time-out detection, and a bit counter. These are used to determine the bus state. The software can get the current bus state by reading the Bus State (BUSSTATE) bit field in the Master Status (TWIn.MSTATUS) register.

The bus state can be Unknown, Idle, Busy or Owner, and it is determined according to the state diagram shown below.

Figure 27-4. Bus State Diagram



- Unknown:** The bus state machine is active when the TWI master is enabled. After the TWI master has been enabled, the bus state is Unknown. The bus state will also be set to Unknown after a System Reset is performed or after the TWI master is disabled.
- Idle:** The bus state machine can be forced to enter the Idle state by writing  $0 \times 1$  to the Bus State (BUSSTATE) bit field. The bus state logic cannot be forced into any other state. If no state is set by the application software, the bus state will become Idle when the first Stop condition is detected. If the Inactive Bus Time-Out (TIMEOUT) bit field from the Master Control A (TWIn.MCTRLA) register is configured to a nonzero value, the bus state will change to Idle on the occurrence of a time-out. When the bus is Idle, it is ready for a new transaction.
- Busy:** If a Start condition, generated externally, is detected when the bus is Idle, the bus state becomes Busy. The bus state changes back to Idle when a Stop condition is detected or when a time-out, if configured, is set.
- Owner:** If a Start condition is generated internally when the bus is Idle, the bus state becomes Owner. If the complete transaction is performed without interference, the master issues a Stop condition and the bus state

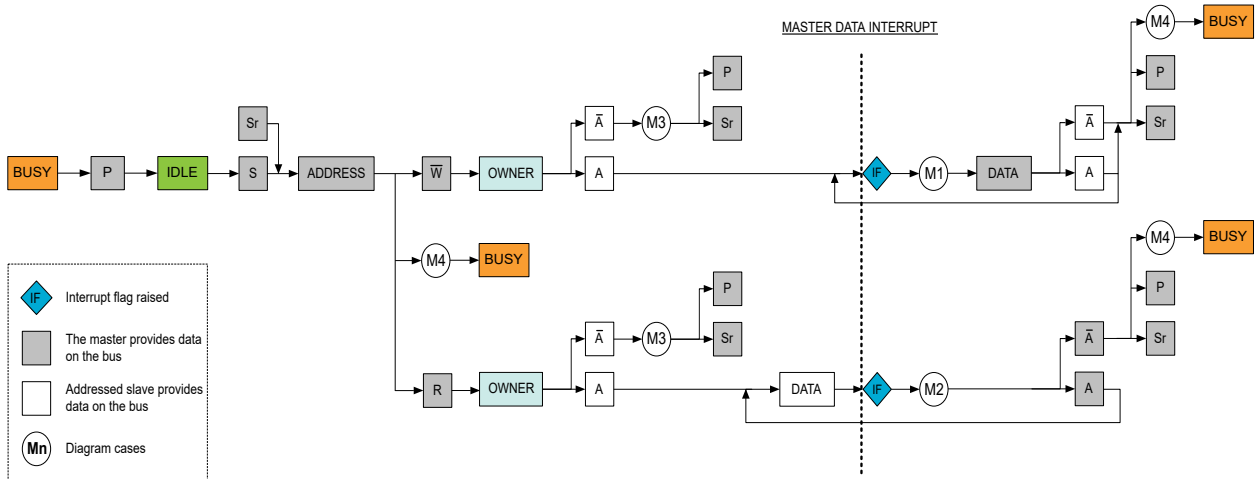
changes back to Idle. If a collision is detected, the arbitration is lost and the bus state becomes Busy until a Stop condition is detected.

### 27.3.2.2.3 Transmitting Address Packets

The master starts performing a bus transaction when the Master Address (TWIn.MADDR) register is written with the slave address and the  $R/\bar{W}$  direction bit. The value of the MADDR register is then copied in the Master Data (TWIn.MDATA) register. If the bus state is Busy, the TWI master will wait until the bus state becomes Idle before issuing the Start condition. The TWI will issue a Start condition, and the shift register performs a byte transmit operation on the bus.

Depending on the arbitration and the  $R/\bar{W}$  direction bit, one of four cases (M1 to M4) arises after the transmission of the address packet.

**Figure 27-5. TWI Master Operation**



#### Case M1: Address Packet Transmit Complete - Direction Bit Set to '0'

If a slave device responds to the address packet with an ACK, the Write Interrupt Flag (WIF) is set to '1', the Received Acknowledge (RXACK) flag is set to '0', and the Clock Hold (CLKHOLD) flag is set to '1'. The WIF, RXACK and CLKHOLD flags are located in the Master Status (TWIn.MSTATUS) register.

The clock hold is active at this point, forcing the SCL low. This will stretch the low period of the clock to slow down the overall clock frequency, forcing delays required to process the data and preventing further activity on the bus.

The software can prepare to:

- Transmit data packets to the slave

#### Case M2: Address Packet Transmit Complete - Direction Bit Set to '1'

If a slave device responds to the address packet with an ACK, the RXACK flag is set to '0', and the slave can start sending data to the master without any delays because the slave owns the bus at this moment. The clock hold is active at this point, forcing the SCL low.

The software can prepare to:

- Read the received data packet from the slave

#### Case M3: Address Packet Transmit Complete - Address not Acknowledged by Slave

If no slave device responds to the address packet, the WIF and the RXACK flags will be set to '1'. The clock hold is active at this point, forcing the SCL low.

The missing ACK response can indicate that the I<sup>2</sup>C slave is busy with other tasks, or it is in a sleep mode, and it is not able to respond.

The software can prepare to take one of the following actions:

- Retransmit the address packet
- Complete the transaction by issuing a Stop condition in the Command (MCMD) bit field from the Master Control B (TWIn.MCTRLB) register, which is the recommended action

**Case M4: Arbitration Lost or Bus Error**

If arbitration is lost, both the WIF and the Arbitration Lost (ARBLOST) flags in the Master Status (TWIn.MSTATUS) register are set to '1'. The SDA is disabled and the SCL is released. The bus state changes to Busy, and the master is no longer allowed to perform any operation on the bus until the bus state is changed back to Idle.

A bus error will behave similarly to the arbitration lost condition. In this case, the Bus Error (BUSERR) flag in the Master Status (TWIn.MSTATUS) register is set to '1', in addition to the WIF and ARBLOST flags.

The software can prepare to:

- Abort the operation and wait until the bus state changes to Idle by reading the Bus State (BUSSTATE) bit field in the Master Status (TWIn.MSTATUS) register

**27.3.2.2.4 Transmitting Data Packets**

Assuming the above M1 case, the TWI master can start transmitting data by writing to the Master Data (TWIn.MDATA) register, which will also clear the Write Interrupt Flag (WIF). During the data transfer, the master is continuously monitoring the bus for collisions and errors. The WIF flag will be set to '1' after the data packet transfer has been completed.

If the transmission is successful and the master receives an ACK bit from the slave, the Received Acknowledge (RXACK) flag will be set to '0', meaning that the slave is ready to receive new data packets.

The software can prepare to take one of the following actions:

- Transmit a new data packet
- Transmit a new address packet
- Complete the transaction by issuing a Stop condition in the Command (MCMD) bit field from the Master Control B (TWIn.MCTRLB) register

If the transmission is successful and the master receives a NACK bit from the slave, the RXACK flag will be set to '1', meaning that the slave is not able to or does not need to receive more data.

The software can prepare to take one of the following actions:

- Transmit a new address packet
- Complete the transaction by issuing a Stop condition in the Command (MCMD) bit field from the Master Control B (TWIn.MCTRLB) register

The RXACK status is valid only if the WIF flag is set to '1' and the Arbitration Lost (ARBLOST) and Bus Error (BUSERR) flags are set to '0'.

The transmission can be unsuccessful if a collision is detected. Then, the master will lose arbitration, the Arbitration Lost (ARBLOST) flag will be set to '1', and the bus state changes to Busy. An arbitration lost during the sending of the data packet is treated the same way as the above M4 case.

The WIF, ARBLOST, BUSERR and RXACK flags are all located in the Master Status (TWIn.MSTATUS) register.

**27.3.2.2.5 Receiving Data Packets**

Assuming the M2 case above, the clock is released for one byte, allowing the slave to put one byte of data on the bus. The master will receive one byte of data from the slave, and the Read Interrupt Flag (RIF) will be set to '1' together with the Clock Hold (CLKHOLD) flag. The action selected by the Acknowledge Action (ACKACT) bit in the Master Control B (TWIn.MCTRLB) register is automatically sent on the bus when a command is written to the Command (MCMD) bit field in the TWIn.MCTRLB register.

The software can prepare to take one of the following actions:

- Respond with an ACK by writing '0' to the ACKACT bit in the TWIn.MCTRLB register and prepare to receive a new data packet
- Respond with a NACK by writing '1' to the ACKACT bit and then transmit a new address packet
- Respond with a NACK by writing '1' to the ACKACT bit and then complete the transaction by issuing a Stop condition in the MCMD bit field from the TWIn.MCTRLB register

A NACK response might not be successfully executed, as arbitration can be lost during the transmission. If a collision is detected, the master loses arbitration, and the Arbitration Lost (ARBLOST) flag is set to '1' and the bus state changes to Busy. The Master Write Interrupt Flag (WIF) is set if the arbitration was lost when sending a NACK or a

bus error occurred during the procedure. An arbitration lost during the sending of the data packet is treated in the same way as the above M4 case.

The RIF, CLKHOLD, ARBLOST and WIF flags are all located in the Master Status (TWIn.MSTATUS) register.

**Note:** The RIF and WIF flags are mutually exclusive and cannot be set simultaneously.

### 27.3.2.3 TWI Slave Operation

The TWI slave is byte-oriented with optional interrupts after each byte. There are separate interrupt flags for the slave data and for address/Stop recognition. Interrupt flags can also be used for polled operation. There are dedicated status flags for indicating ACK/NACK received, clock hold, collision, bus error, and R/W direction bit.

When an interrupt flag is set to '1', the SCL is forced low. This will give the slave time to respond or handle any data, and will, in most cases, require software interaction. The number of interrupts generated is kept to a minimum by automatic handling of most conditions.

The Address Recognition Mode (PMEN) bit in the Slave Control A (TWIn.SCTRLA) register can be configured to allow the slave to respond to all received addresses.

#### 27.3.2.3.1 Receiving Address Packets

When the TWI is configured as a slave, it will wait for a Start condition to be detected. When this happens, the successive address packet will be received and checked by the address match logic. The slave will ACK a correct address and store the address in the Slave Data (TWIn.SDATA) register. If the received address is not a match, the slave will not acknowledge or store the address, but wait for a new Start condition.

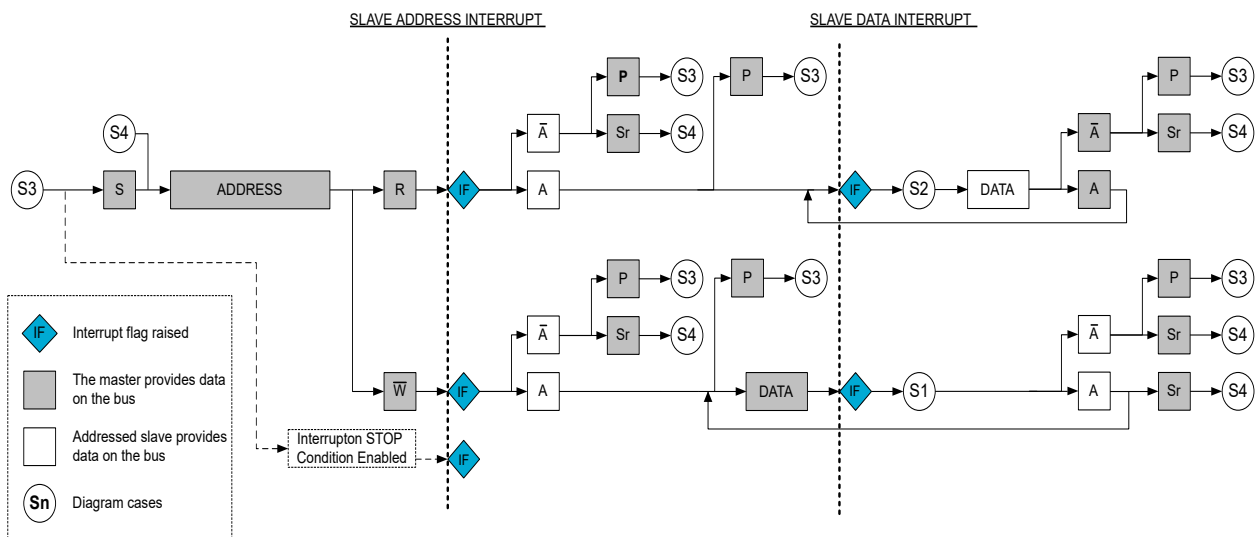
The Address or Stop Interrupt Flag (APIF) in the Slave Status (TWIn.SSTATUS) register is set to '1' when a Start condition is succeeded by one of the following:

- A valid address match with the address stored in the Address (ADDR[7:1]) bit field in the Slave Address (TWIn.SADDR) register
- The General Call Address 0x00, and the Address (ADDR[0]) bit in the Slave Address (TWIn.SADDR) register is set to '1'
- A valid address match with the secondary address stored in the Address Mask (ADDRMASK) bit field and the Address Mask Enable (ADDREN) bit is set to '1' in the Slave Address Mask (TWIn.SADDRMASK) register
- Any address if the Address Recognition Mode (PMEN) bit in the Slave Control A (TWIn.SCTRLA) register is set to '1'

A Start condition immediately followed by a Stop condition is an illegal operation, and the Bus Error (BUSERR) flag in the Slave Status (TWIn.SSTATUS) register is set.

Depending on the Read/Write Direction (DIR) bit in the Slave Status (TWIn.SSTATUS) register and the bus condition, one of four distinct cases (S1 to S4) arises after the reception of the address packet.

Figure 27-6. TWI Slave Operation



**Case S1: Address Packet Accepted - Direction Bit Set to '0'**

If an ACK is sent by the slave after the address packet is received and the Read/Write Direction (DIR) bit in the Slave Status (TWIn.SSTATUS) register is set to '0', the master indicates a write operation.

The clock hold is active at this point, forcing the SCL low. This will stretch the low period of the clock to slow down the overall clock frequency, forcing delays required to process the data and preventing further activity on the bus.

The software can prepare to:

- Read the received data packet from the master

**Case S2: Address Packet Accepted - Direction Bit Set to '1'**

If an ACK is sent by the slave after the address packet is received and the DIR bit is set to '1', the master indicates a read operation, and the Data Interrupt Flag (DIF) in the Slave Status (TWIn.SSTATUS) register will be set to '1'.

The clock hold is active at this point, forcing the SCL low.

The software can prepare to:

- Transmit data packets to the master

**Case S3: Stop Condition Received**

When the Stop condition is received, the Address or Stop (AP) flag will be set to '0', indicating that a Stop condition, and not an address match, activated the Address or Stop Interrupt Flag (APIF).

The AP and APIF flags are located in the Slave Status (TWIn.SSTATUS) register.

The software can prepare to:

- Wait until a new address packet will be addressed to it

**Case S4: Collision**

If the slave is not able to send a high-level data bit or a NACK, the Collision (COLL) bit in the Slave Status (TWIn.SSTATUS) register is set to '1'. The slave will commence its operation as normal, except no low values will be shifted out on the SDA. The data and acknowledge output from the slave logic will be disabled. The clock hold is released. A Start or repeated Start condition will be accepted.

The COLL bit is intended for systems where the Address Resolution Protocol (ARP) is employed. A detected collision in non-ARP situations indicates that there has been a protocol violation and must be treated as a bus error.

**27.3.2.3.2 Receiving Data Packets**

Assuming the above S1 case, the slave must be ready to receive data. When a data packet is received, the Data Interrupt Flag (DIF) in the Slave Status (TWIn.SSTATUS) register is set to '1'. The action selected by the Acknowledge Action (ACKACT) bit in the Slave Control B (TWIn.SCTRLB) register is automatically sent on the bus when a command is written to the Command (SCMD) bit field in the TWIn.SCTRLB register.

The software can prepare to take one of the following actions:

- Respond with an ACK by writing '0' to the ACKACT bit in the TWIn.SCTRLB register, indicating that the slave is ready to receive more data
- Respond with a NACK by writing '1' to the ACKACT bit, indicating that the slave cannot receive any more data and the master must issue a Stop or repeated Start condition

**27.3.2.3.3 Transmitting Data Packets**

Assuming the above S2 case, the slave can start transmitting data by writing to the Slave Data (TWIn.SDATA) register. When a data packet transmission is completed, the Data Interrupt Flag (DIF) in the Slave Status (TWIn.SSTATUS) register is set to '1'.

The software can prepare to take one of the following actions:

- Check if the master responded with an ACK by reading the Received Acknowledge (RXACK) bit from the Slave Status (TWIn.SSTATUS) register and start transmitting new data packets
- Check if the master responded with a NACK by reading the RXACK and stop transmitting data packets. The master must send a Stop or repeated Start condition after the NACK.

### 27.3.3 Additional Features

#### 27.3.3.1 SMBus

If the TWI is used in an SMBus environment, the Inactive Bus Time-Out (TIMEOUT) bit field from the Master Control A (TWIn.MCTRLA) register must be configured. It is recommended to write to the Master Baud Rate (TWIn.MBAUD) register before setting the time-out because it is dependent on the baud rate setting.

A frequency of 100 kHz can be used for the SMBus environment. For the Standard mode (Sm) and Fast mode (Fm), the operating frequency has slew rate limited output, while for the Fast mode Plus (Fm+), it has x10 output drive strength.

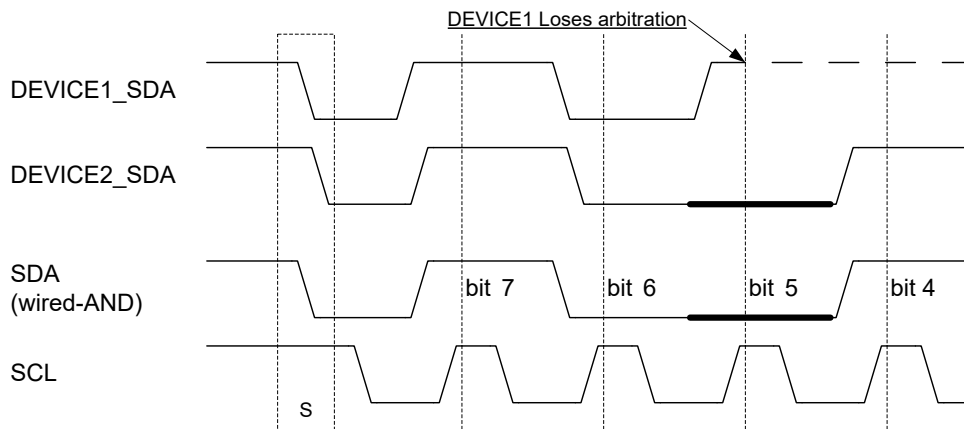
The TWI also allows for an SMBus compatible SDA hold time configured in the SDA Hold Time (SDAHOLD) bit field from the Control A (TWIn.CTRLA) register.

#### 27.3.3.2 Multi Master

A master can start a bus transaction only if it has detected that the bus is in the Idle state. As the TWI bus is a multi-master bus, more devices may try to initiate a transaction at the same time. This results in multiple masters owning the bus simultaneously. The TWI solves this problem by using an arbitration scheme where the master loses control of the bus if it is not able to transmit a high-level data bit on the SDA and the Bus State (BUSSTATE) bit field from the Master Status (TWIn.MSTATUS) register will be changed to Busy. The masters that lose the arbitration must wait until the bus becomes Idle before attempting to reacquire the bus ownership.

Both devices can issue a Start condition, but DEVICE1 loses arbitration when attempting to transmit a high level (bit 5) while DEVICE2 is transmitting a low level.

**Figure 27-7. TWI Arbitration**



#### 27.3.3.3 Smart Mode

The TWI interface has a Smart mode that simplifies the application code and minimizes the user interaction needed to adhere to the I<sup>2</sup>C protocol.

For the TWI Master, the Smart mode will automatically send the ACK action as soon as the Master Data (TWIn.MDATA) register is read. This feature is only active when the Acknowledge Action (ACKACT) bit in the Master Control B (TWIn.MCTRLB) register is set to ACK. If the ACKACT bit is set to NACK, the TWI Master will not generate a NACK after the MDATA register is read. This feature is enabled when the Smart Mode Enable (SMEN) bit in the Master Control A (TWIn.MCTRLA) register is set to '1'.

For the TWI Slave, the Smart mode will automatically send the ACK action as soon as the Slave Data (TWIn.SDATA) register is read. The Smart mode will automatically set the Data Interrupt Flag (DIF) to '0' in the Slave Status (TWIn.SSTATUS) register if the TWIn.SDATA register is read or written. This feature is enabled when the Smart Mode Enable (SMEN) bit in the Slave Control A (TWIn.SCTRLA) register is set to '1'.

#### 27.3.3.4 Dual Mode

The TWI supports Dual mode operation where the master and the slave will operate simultaneously and independently. In this case, the Control A (TWIn.CTRLA) register will configure the master device, and the Dual Mode Control (TWIn.DUALCTRL) register will configure the slave device. See the [27.3.2.1 Initialization](#) section for more details about the master configuration.

If used, the following bits must be configured before enabling the TWI Dual mode:

- The SDA Hold Time (SDAHOLD) bit field
- The FM Plus Enable (FMPEN) bit from the DUALCTRL register

The Dual mode can be enabled by writing a '1' to the Dual Control Enable (ENABLE) bit in the DUALCTRL register.

### 27.3.3.5 Quick Command Mode

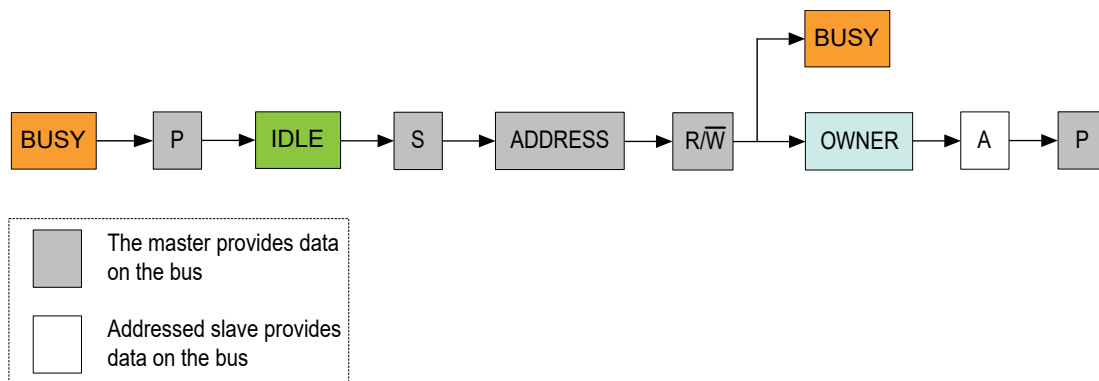
With Quick Command mode, the  $R/\bar{W}$  bit from the address packet denotes the command. This mode is enabled by writing '1' to the Quick Command Enable (QCEN) bit in the Master Control A (TWIn.MCTRLA) register. There are no data sent or received.

The Quick Command mode is SMBus specific, where the  $R/\bar{W}$  bit can be used to turn a device function on/off or to enable/disable a low-power Standby mode. This mode can be enabled to auto-trigger operations and reduce the software complexity.

After the master receives an ACK from the slave, either the Read Interrupt Flag (RIF) or Write Interrupt Flag (WIF) will be set, depending on the value of the  $R/\bar{W}$  bit. When either the RIF or WIF flag is set after issuing a Quick Command, the TWI will accept a Stop command by writing the Command (MCMD) bit field in the Master Control B (TWIn.MCTRLB) register.

The RIF and WIF flags, together with the value of the last Received Acknowledge (RXACK) flag are all located in the Master Status (TWIn.MSTATUS) register.

**Figure 27-8. Quick Command Frame Format**



### 27.3.3.6 10-bit Address

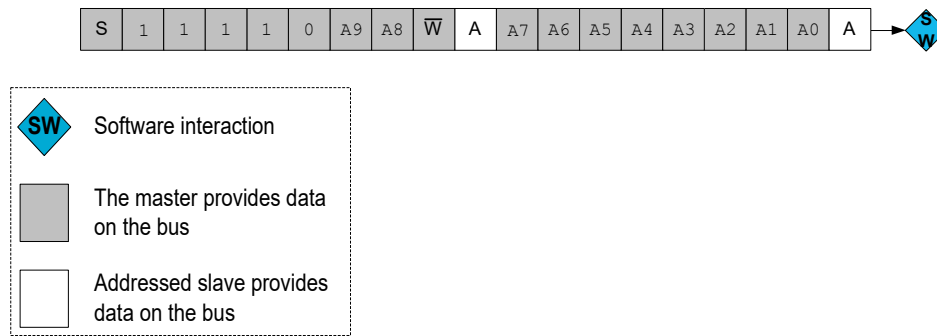
Regardless of whether the transaction is a read or write, the master must start by sending the 10-bit address with the  $R/\bar{W}$  direction bit set to '0'.

The slave address match logic supports recognition of 7-bit addresses and general call address. The Slave Address (TWIn.SADDR) register is used by the slave address match logic to determine if a master device has addressed the TWI slave.

The TWI slave address match logic only supports recognition of the first byte of a 10-bit address and the second byte must be handled in software. The first byte of the 10-bit address will be recognized if the upper five bits of the Slave Address (TWIn.SADDR) register are 0b11110. Thus, the first byte will consist of five indication bits, the two Most Significant bits (MSb) of the 10-bits address, and the  $R/\bar{W}$  direction bit. The Least Significant Byte (LSB) of the address that follows from the master will come in the form of a data packet.



Figure 27-9. 10-bit Address Transmission



### 27.3.4 Interrupts

Table 27-1. Available Interrupt Vectors and Sources

Name	Vector Description	Conditions
Slave	TWI Slave interrupt	<ul style="list-style-type: none"> <li>DIF: Data Interrupt Flag in TWIn.SSTATUS is set to '1'</li> <li>APIF: Address or Stop Interrupt Flag in TWIn.SSTATUS is set to '1'</li> </ul>
Master	TWI Master interrupt	<ul style="list-style-type: none"> <li>RIF: Read Interrupt Flag in TWIn.MSTATUS is set to '1'</li> <li>WIF: Write Interrupt Flag in TWIn.MSTATUS is set to '1'</li> </ul>

When an interrupt condition occurs, the corresponding interrupt flag is set in the Master Status (TWIn.MSTATUS) register or the Slave Status (TWIn.SSTATUS) register.

When several interrupt request conditions are supported by an interrupt vector, the interrupt requests are ORed together into one combined interrupt request to the interrupt controller. The user must read the Interrupt flags from the TWIn.MSTATUS register or the TWIn.SSTATUS register, to determine which of the interrupt conditions are present.

### 27.3.5 Sleep Mode Operation

The bus state logic and the address recognition hardware continue to operate in all sleep modes. If a slave device is in sleep mode and a Start condition followed by the address of the slave is detected, clock stretching is active during the wake-up period until the main clock is available. The master will stop operation in all sleep modes. When the Dual mode is active, the device will wake up only when the Start condition is sent on the bus of the slave.

### 27.3.6 Debug Operation

During run-time debugging, the TWI will continue normal operation. Halting the CPU in Debugging mode will halt the normal operation of the TWI. The TWI can be forced to operate with halted CPU by writing a '1' to the Debug Run (DBGRUN) bit in the Debug Control (TWIn.DBGCTRL) register. When the CPU is halted in Debug mode and the DBGRUN bit is '1', reading or writing the Master Data (TWIn.MDATA) register or the Slave Data (TWIn.SDATA) register will neither trigger a bus operation, nor cause transmit and clear flags. If the TWI is configured to require periodical service by the CPU through interrupts or similar, improper operation or data loss may result during halted debugging.

## 27.4 Register Summary

Offset	Name	Bit Pos.	7	6	5	4	3	2	1	0	
0x00	<a href="#">CTRLA</a>	7:0		INPUTLVL		SDASETUP	SDAHOLD[1:0]		FMPEN		
0x01	<a href="#">DUALCTRL</a>	7:0		INPUTLVL			SDAHOLD[1:0]		FMPEN	ENABLE	
0x02	<a href="#">DBGCTRL</a>	7:0								DBGRUN	
0x03	<a href="#">MCTRLA</a>	7:0	RIEN	WIEN		QCEN	TIMEOUT[1:0]		SMEN	ENABLE	
0x04	<a href="#">MCTRLB</a>	7:0					FLUSH	ACKACT	MCMD[1:0]		
0x05	<a href="#">MSTATUS</a>	7:0	RIF	WIF	CLKHOLD	RXACK	ARBLOST	BUSERR	BUSSTATE[1:0]		
0x06	<a href="#">MBAUD</a>	7:0	BAUD[7:0]								
0x07	<a href="#">MADDR</a>	7:0	ADDR[7:0]								
0x08	<a href="#">MDATA</a>	7:0	DATA[7:0]								
0x09	<a href="#">SCTRLA</a>	7:0	DIEN	APIEN	PIEN			PMEN	SMEN	ENABLE	
0x0A	<a href="#">SCTRLB</a>	7:0						ACKACT	SCMD[1:0]		
0x0B	<a href="#">SSTATUS</a>	7:0	DIF	APIF	CLKHOLD	RXACK	COLL	BUSERR	DIR	AP	
0x0C	<a href="#">SADDR</a>	7:0	ADDR[7:0]								
0x0D	<a href="#">SDATA</a>	7:0	DATA[7:0]								
0x0E	<a href="#">SADDRMASK</a>	7:0	ADDRMASK[6:0]								ADDREN

## 27.5 Register Description

## 27.5.1 Control A

**Name:** CTRLA  
**Offset:** 0x00  
**Reset:** 0x00  
**Property:** -

Bit	7	6	5	4	3	2	1	0
		INPUTLVL		SDASETUP	SDAHOLD[1:0]		FMPEN	
Access		R/W		R/W	R/W	R/W	R/W	
Reset		0		0	0	0	0	

**Bit 6 – INPUTLVL** Input Voltage Transition Level  
 This bit is used to select between I<sup>2</sup>C and SMBUS.

Value	Name	Description
0	I2C	I <sup>2</sup> C input voltage transition level
1	SMBUS	SMBus 3.0 input voltage transition level

**Bit 4 – SDASETUP** SDA Setup Time

By default, there are four clock cycles of setup time on the SDA out signal while reading from the slave part of the TWI module.

Value	Name	Description
0	4CYC	SDA setup time is four clock cycles
1	8CYC	SDA setup time is eight clock cycles

**Bits 3:2 – SDAHOLD[1:0]** SDA Hold Time

This bit field selects the SDA hold time for the TWI. See the *Electrical Characteristics* section for details.

Value	Name	Description
0x0	OFF	Hold time OFF
0x1	50NS	Short hold time
0x2	300NS	Meets the SMBus 2.0 specifications under typical conditions
0x3	500NS	Meets the SMBus 2.0 across all corners

**Bit 1 – FMPEN** FM Plus Enable

Writing a '1' to this bit selects the 1 MHz bus speed for the TWI in default configuration or for the TWI Master in Dual mode configuration.

Value	Name	Description
0	OFF	Operating in Standard mode or Fast mode
1	ON	Operating in Fast mode Plus

### 27.5.2 Dual Mode Control Configuration

**Name:** DUALCTRL  
**Offset:** 0x01  
**Reset:** 0x00  
**Property:** -

Bit	7	6	5	4	3	2	1	0
		INPUTLVL			SDAHOLD[1:0]		FMPEN	ENABLE
Access		R/W			R/W	R/W	R/W	R/W
Reset		0			0	0	0	0

**Bit 6 – INPUTLVL** Input Voltage Transition Level  
 This bit is used to select between I<sup>2</sup>C and SMBUS.

Value	Name	Description
0	I2C	I <sup>2</sup> C input voltage transition level
1	SMBUS	SMBus 3.0 input voltage transition level

**Bits 3:2 – SDAHOLD[1:0]** SDA Hold Time  
 This bit field selects the SDA hold time for the TWI Slave. This bit field is ignored if the Dual mode is not enabled.

Value	Name	Description
0x0	OFF	Hold time OFF
0x1	50NS	Short hold time
0x2	300NS	Meets the SMBus 2.0 specifications under typical conditions
0x3	500NS	Meets the SMBus 2.0 across all corners

**Bit 1 – FMPEN** FM Plus Enable  
 Writing a '1' to this bit selects the 1 MHz bus speed for the TWI Slave.

Value	Name	Description
0	OFF	Operating in Standard mode or Fast mode
1	ON	Operating in Fast mode Plus

**Bit 0 – ENABLE** Dual Control Enable  
 Writing a '1' to this bit will enable the Dual mode configuration.

**27.5.3 Debug Control**

**Name:** DBGCTRL  
**Offset:** 0x02  
**Reset:** 0x00  
**Property:** -

Bit	7	6	5	4	3	2	1	0
Access								R/W
Reset								0

**Bit 0 – DBGRUN** Debug Run

See the [27.3.6 Debug Operation](#) section for more details.

Value	Description
0	The TWI is halted in Break Debug mode and ignores events
1	The TWI will continue to run in Break Debug mode when the CPU is halted

## 27.5.4 Master Control A

**Name:** MCTRLA  
**Offset:** 0x03  
**Reset:** 0x00  
**Property:** -

Bit	7	6	5	4	3	2	1	0
	RIEN	WIEN		QCEN	TIMEOUT[1:0]		SMEN	ENABLE
Access	R/W	R/W		R/W	R/W	R/W	R/W	R/W
Reset	0	0		0	0	0	0	0

**Bit 7 – RIEN** Read Interrupt Enable

A TWI master read interrupt will be generated only if this bit and the Global Interrupt Enable (I) bit in the Status (CPU.SREG) register are set to '1'.

Writing a '1' to this bit enables the interrupt on the Read Interrupt Flag (RIF) in the Master Status (TWIn.MSTATUS) register. When the master read interrupt occurs, the RIF flag is set to '1'.

**Bit 6 – WIEN** Write Interrupt Enable

A TWI master write interrupt will be generated only if this bit and the Global Interrupt Enable (I) bit in the Status (CPU.SREG) register are set to '1'.

Writing a '1' to this bit enables the interrupt on the Write Interrupt Flag (WIF) in the Master Status (TWIn.MSTATUS) register. When the master write interrupt occurs, the WIF flag is set to '1'.

**Bit 4 – QCEN** Quick Command Enable

Writing a '1' to this bit enables the Quick Command mode. If the Quick Command mode is enabled and a slave acknowledges the address, the corresponding Read Interrupt Flag (RIF) or Write Interrupt Flag (WIF) will be set depending on the value of R/W bit.

The software must issue a Stop command by writing to the Command (MCMD) bit field in the Master Control B (TWIn.MCTRLB) register.

**Bits 3:2 – TIMEOUT[1:0]** Inactive Bus Time-Out

Setting this bit field to a nonzero value will enable the inactive bus time-out supervisor. If the bus is inactive for longer than the TIMEOUT setting, the bus state logic will enter the Idle state.

Value	Name	Description
0x0	DISABLED	Bus time-out disabled - I <sup>2</sup> C
0x1	50US	50 μs - SMBus (assume the baud rate is set to 100 kHz)
0x2	100US	100 μs (assume the baud rate is set to 100 kHz)
0x3	200US	200 μs (assume the baud rate is set to 100 kHz)

**Bit 1 – SMEN** Smart Mode Enable

Writing a '1' to this bit enables the Master Smart mode. When the Smart mode is enabled, the existing value in the Acknowledge Action (ACKACT) bit from the Master Control B (TWIn.MCTRLB) register is sent immediately after reading the Master Data (TWIn.MDATA) register.

**Bit 0 – ENABLE** Enable TWI Master

Writing a '1' to this bit enables the TWI as master.

### 27.5.5 Master Control B

**Name:** MCTRLB  
**Offset:** 0x04  
**Reset:** 0x00  
**Property:** -

Bit	7	6	5	4	3	2	1	0
					FLUSH	ACKACT	MCMD[1:0]	
Access					R/W	R/W	R/W	R/W
Reset					0	0	0	0

#### Bit 3 – FLUSH Flush

This bit clears the internal state of the master and the bus states changes to Idle. The TWI will transmit invalid data if the Master Data (TWIn.MDATA) register is written before the Master Address (TWIn.MADDR) register.

Writing a '1' to this bit generates a strobe for one clock cycle, disabling the master, and then re-enabling the master.

Writing a '0' to this bit has no effect.

#### Bit 2 – ACKACT Acknowledge Action

The ACKACT<sup>(1)</sup> bit represents the behavior in the Master mode under certain conditions defined by the bus state and the software interaction. If the Smart Mode Enable (SMEN) bit in the Master Control A (TWIn.MCTRLA) register is set to '1', the acknowledge action is performed when the Master Data (TWIn.MDATA) register is read, else a command must be written to the Command (MCDM) bit field in the Master Control B (TWIn.MCTRLB) register.

The acknowledge action is not performed when the Master Data (TWIn.MDATA) register is written, since the master is sending data.

Value	Name	Description
0	ACK	Send ACK
1	NACK	Send NACK

#### Bits 1:0 – MCMD[1:0] Command

The MCMD<sup>(1)</sup> bit field is a strobe. This bit field is always read as '0'.

Writing to this bit field triggers a master operation as defined by the table below.

**Table 27-2. Command Settings**

MCMD[1:0]	Group Configuration	DIR	Description
0x0	NOACT	X	Reserved
0x1	REPSTART	X	Execute Acknowledge Action followed by repeated Start condition
0x2	RECVTRANS	W	Execute Acknowledge Action (no action) followed by a byte write operation <sup>(2)</sup>
		R	Execute Acknowledge Action followed by a byte read operation
0x3	STOP	X	Execute Acknowledge Action followed by issuing a Stop condition

#### Notes:

1. The ACKACT bit and the MCMD bit field can be written at the same time.
2. For a master write operation, the TWI will wait for new data to be written to the Master Data (TWIn.MDATA) register.

**27.5.6 Master Status**

**Name:** MSTATUS  
**Offset:** 0x05  
**Reset:** 0x00  
**Property:** -

Bit	7	6	5	4	3	2	1	0
	RIF	WIF	CLKHOLD	RXACK	ARBLOST	BUSERR	BUSSTATE[1:0]	
Access	R/W	R/W	R/W	R	R/W	R/W	R/W	R/W
Reset	0	0	0	0	0	0	0	0

**Bit 7 – RIF** Read Interrupt Flag

This flag is set to '1' when the master byte read operation is successfully completed.

The RIF flag can be used for a master read interrupt. More information can be found in the Read Interrupt Enable (RIEN) bit from the Master Control A (TWIn.MCTRLA) register.

This flag is automatically cleared when accessing several other TWI registers. The RIF flag can be cleared by choosing one of the following methods:

1. Writing a '1' to it.
2. Writing to the Master Address (TWIn.MADDR) register.
3. Writing/Reading the Master Data (TWIn.MDATA) register.
4. Writing to the Command (MCMD) bit field from the Master Control B (TWIn.MCTRLB) register.

**Bit 6 – WIF** Write Interrupt Flag

This flag is set to '1' when a master transmit address or byte write operation is completed, regardless of the occurrence of a bus error or arbitration lost condition.

The WIF flag can be used for a master write interrupt. More information can be found from the Write Interrupt Enable (WIEN) bit in the Master Control A (TWIn.MCTRLA) register.

This flag can be cleared by choosing one of the methods described for the RIF flag.

**Bit 5 – CLKHOLD** Clock Hold

When this bit is read as '1', it indicates that the master is currently holding the SCL low, stretching the TWI clock period.

This bit can be cleared by choosing one of the methods described for the RIF flag.

**Bit 4 – RXACK** Received Acknowledge

When this flag is read as '0', it indicates that the most recent Acknowledge bit from the slave was ACK and the slave is ready for more data.

When this flag is read as '1', it indicates that the most recent Acknowledge bit from the slave was NACK and the slave is not able to or does not need to receive more data.

**Bit 3 – ARBLOST** Arbitration Lost

When this bit is read as '1', it indicates that the master has lost arbitration. This can happen in one of the following cases:

1. While transmitting a high data bit.
2. While transmitting a NACK bit.
3. While issuing a Start condition (S).
4. While issuing a repeated Start (Sr).

This flag can be cleared by choosing one of the methods described for the RIF flag.

**Bit 2 – BUSERR** Bus Error

The BUSERR flag indicates that an illegal bus operation has occurred. An illegal bus operation is detected if a protocol violating the Start (S), repeated Start (Sr), or Stop (P) conditions is detected on the TWI bus lines. A Start condition directly followed by a Stop condition is one example of a protocol violation.



The BUSERR flag can be cleared by choosing one of the following methods:

1. Writing a '1' to it.
2. Writing to the Master Address (TWIn.MADDR) register.

The TWI bus error detector is part of the TWI Master circuitry. For the bus errors to be detected, the TWI Master must be enabled (ENABLE bit in TWIn.MCTRLA is '1'), and the main clock frequency must be at least four times the SCL frequency.

**Bits 1:0 – BUSSTATE[1:0] Bus State**

This bit field indicates the current TWI bus state.

Value	Name	Description
0x0	UNKNOWN	Unknown bus state
0x1	IDLE	Idle bus state
0x2	OWNER	This TWI controls the bus
0x3	BUSY	Busy bus state

**27.5.7 Master Baud Rate**

**Name:** MBAUD  
**Offset:** 0x06  
**Reset:** 0x00  
**Property:** -

Bit	7	6	5	4	3	2	1	0
	BAUD[7:0]							
Access	R/W	R/W	R/W	R/W	R/W	R/W	R/W	R/W
Reset	0	0	0	0	0	0	0	0

**Bits 7:0 – BAUD[7:0] Baud Rate**

This bit field is used to derive the SCL high and low time. It must be written while the master is disabled. The master can be disabled by writing '0' to the Enable TWI Master (ENABLE) bit from the Master Control A (TWIn.MCTRLA) register.

Refer to the [27.3.2.2.1 Clock Generation](#) section for more information on how to calculate the frequency of the SCL.

**27.5.8 Master Address**

**Name:** MADDR  
**Offset:** 0x07  
**Reset:** 0x00  
**Property:** -

Bit	7	6	5	4	3	2	1	0
	ADDR[7:0]							
Access	R/W	R/W	R/W	R/W	R/W	R/W	R/W	R/W
Reset	0	0	0	0	0	0	0	0

**Bits 7:0 – ADDR[7:0] Address**

This register contains the address of the external slave device. When this bit field is written, the TWI will issue a Start condition, and the shift register performs a byte transmit operation on the bus depending on the bus state.

This register can be read at any time without interfering with the ongoing bus activity since a read access does not trigger the master logic to perform any bus protocol related operations.

The master control logic uses the bit 0 of this register as the R/W direction bit.

**27.5.9 Master Data**

**Name:** MDATA  
**Offset:** 0x08  
**Reset:** 0x00  
**Property:** -

Bit	7	6	5	4	3	2	1	0
	DATA[7:0]							
Access	R/W	R/W	R/W	R/W	R/W	R/W	R/W	R/W
Reset	0	0	0	0	0	0	0	0

**Bits 7:0 – DATA[7:0] Data**

This bit field provides direct access to the master's physical shift register, which is used to shift out data on the bus (transmit) and to shift in data received from the bus (receive). The direct access implies that the MDATA register cannot be accessed during byte transmissions.

Reading valid data or writing data to be transmitted can only be successful when the CLKHOLD bit is read as '1' or when an interrupt occurs.

A write access to the MDATA register will command the master to perform a byte transmit operation on the bus, directly followed by receiving the Acknowledge bit from the slave. This is independent of the Acknowledge Action (ACKACT) bit from the Master Control B (TWIn.MCTRLB) register. The write operation is performed regardless of winning or losing arbitration before the Write Interrupt Flag (WIF) is set to '1'.

If the Smart Mode Enable (SMEN) bit in the Master Control A (TWIn.MCTRLA) register is set to '1', a read access to the MDATA register will command the master to perform an acknowledge action. This is dependent on the setting of the Acknowledge Action (ACKACT) bit from the Master Control B (TWIn.MCTRLB) register.

**Notes:**

1. The WIF and RIF interrupt flags are cleared automatically if the MDATA register is read while ACKACT is set to '1'.
2. The ARBLOST and BUSEER flags are left unchanged.
3. The WIF, RIF, ARBLOST, and BUSERR flags together with the Clock Hold (CLKHOLD) bit are all located in the Master Status (TWIn.MSTATUS) register.

**27.5.10 Slave Control A**

**Name:** SCTRLA  
**Offset:** 0x09  
**Reset:** 0x00  
**Property:** -

Bit	7	6	5	4	3	2	1	0
	DIEN	APIEN	PIEN			PMEN	SMEN	ENABLE
Access	R/W	R/W	R/W			R/W	R/W	R/W
Reset	0	0	0			0	0	0

**Bit 7 – DIEN** Data Interrupt Enable

Writing this bit to '1' enables an interrupt on the Data Interrupt Flag (DIF) from the Slave Status (TWIn.SSTATUS) register.

A TWI slave data interrupt will be generated only if this bit, the DIF flag, and the Global Interrupt Enable (I) bit in Status (CPU.SREG) register are all '1'.

**Bit 6 – APIEN** Address or Stop Interrupt Enable

Writing this bit to '1' enables an interrupt on the Address or Stop Interrupt Flag (APIF) from the Slave Status (TWIn.SSTATUS) register.

A TWI slave address or stop interrupt will be generated only if this bit, the APIF flag, and the Global Interrupt Enable (I) bit in the Status (CPU.SREG) register are all '1'.

**Notes:**

1. The slave stop interrupt shares the interrupt flag and vector with the slave address interrupt.
2. The Stop Interrupt Enable (PIEN) bit in the Slave Control A (TWIn.SCTRLA) register must be written to '1' for the APIF to be set on a Stop condition.
3. When the interrupt occurs, the Address or Stop (AP) bit in the Slave Status (TWIn.SSTATUS) register will determine whether an address match or a Stop condition caused the interrupt.

**Bit 5 – PIEN** Stop Interrupt Enable

Writing this bit to '1' allows the Address or Stop Interrupt Flag (APIF) in the Slave Status (TWIn.SSTATUS) register to be set when a Stop condition occurs. To use this feature, the main clock frequency must be at least four times the SCL frequency.

**Bit 2 – PMEN** Address Recognition Mode

If this bit is written to '1', the slave address match logic responds to all received addresses.

If this bit is written to '0', the address match logic uses the Slave Address (TWIn.SADDR) register to determine which address to recognize as the slave's address.

**Bit 1 – SMEN** Smart Mode Enable

Writing this bit to '1' enables the slave Smart mode. When the Smart mode is enabled, issuing a command by writing to the Command (SCMD) bit field in the Slave Control B (TWIn.SCTRLB) register or accessing the Slave Data (TWIn.SDATA) register resets the interrupt, and the operation continues. If the Smart mode is disabled, the slave always waits for a new slave command before continuing.

**Bit 0 – ENABLE** Enable TWI Slave

Writing this bit to '1' enables the TWI slave.

## 27.5.11 Slave Control B

**Name:** SCTRLB  
**Offset:** 0x0A  
**Reset:** 0x00  
**Property:** -

Bit	7	6	5	4	3	2	1	0
Access						ACKACT	SCMD[1:0]	
Reset						R/W	R/W	R/W
						0	0	0

**Bit 2 – ACKACT** Acknowledge Action

The ACKACT<sup>(1)</sup> bit represents the behavior of the slave device under certain conditions defined by the bus protocol state and the software interaction. If the Smart Mode Enable (SMEN) bit in the Slave Control A (TWIn.SCTRLA) register is set to '1', the acknowledge action is performed when the Slave Data (TWIn.SDATA) register is read, else a command must be written to the Command (SCMD) bit field in the Slave Control B (TWIn.SCTRLB) register. The acknowledge action is not performed when the Slave Data (TWIn.SDATA) register is written, since the slave is sending data.

Value	Name	Description
0	ACK	Send ACK
1	NACK	Send NACK

**Bits 1:0 – SCMD[1:0]** Command

The SCMD<sup>(1)</sup> bit field is a strobe. This bit field is always read as '0'.

Writing to this bit field triggers a slave operation as defined by the table below.

**Table 27-3. Command Settings**

SCMD[1:0]	Group Configuration	DIR	Description
0x0	NOACT	X	No action
0x1	—	X	Reserved
0x2	COMPTRANS	W	Used to complete a transaction Execute Acknowledge Action succeeded by waiting for any Start (S/Sr) condition
		R	Wait for any Start (S/Sr) condition
0x3	RESPONSE	W	Used in response to an address interrupt (APIF) Execute Acknowledge Action succeeded by reception of next byte
		R	Execute Acknowledge Action succeeded by slave data interrupt
		W	Used in response to a data interrupt (DIF) Execute Acknowledge Action succeeded by reception of next byte
		R	Execute a byte read operation followed by Acknowledge Action

**Note:** 1. The ACKACT bit and the SCMD bit field can be written at the same time. The ACKACT will be updated before the command is triggered.

**27.5.12 Slave Status**

**Name:** SSTATUS  
**Offset:** 0x0B  
**Reset:** 0x00  
**Property:** -

Bit	7	6	5	4	3	2	1	0
	DIF	APIF	CLKHOLD	RXACK	COLL	BUSERR	DIR	AP
Access	R/W	R/W	R	R	R/W	R/W	R	R
Reset	0	0	0	0	0	0	0	0

**Bit 7 – DIF** Data Interrupt Flag

This flag is set to '1' when the slave byte transmit or receive operation is successfully completed without any bus errors. This flag can be set to '1' with an unsuccessful transaction in case of a collision detection. More information can be found in the Collision (COLL) bit description.

The DIF flag can generate a slave data interrupt. More information can be found in Data Interrupt Enable (DIEN) bit from the Slave Control A (TWIn.SCTRLA) register.

This flag is automatically cleared when accessing several other TWI registers. The DIF flag can be cleared by choosing one of the following methods:

1. Writing/Reading the Slave Data (TWIn.SDATA) register.
2. Writing to the Command (SCMD) bit field from the Slave Control B (TWIn.SCTRLB) register.

**Bit 6 – APIF** Address or Stop Interrupt Flag

This flag is set to '1' when the slave address has been received or by a Stop condition.

The APIF flag can generate a slave address or stop interrupt. More information can be found in the Address or Stop Interrupt Enable (APIEN) bit from the Slave Control A (TWIn.SCTRLA) register.

This flag can be cleared by choosing one of the methods described for the DIF flag.

**Bit 5 – CLKHOLD** Clock Hold

When this bit is read as '1', it indicates that the slave is currently holding the SCL low, stretching the TWI clock period.

This bit is set to '1' when an address or data interrupt occurs. Resetting the corresponding interrupt will indirectly set this bit to '0'.

**Bit 4 – RXACK** Received Acknowledge

When this flag is read as '0', it indicates that the most recent Acknowledge bit from the master was ACK.

When this flag is read as '1', it indicates that the most recent Acknowledge bit from the master was NACK.

**Bit 3 – COLL** Collision

When this bit is read as '1', it indicates that the slave has not been able to do one of the following:

1. Transmit high bits on the SDA. The Data Interrupt Flag (DIF) will be set to '1' at the end as a result of the internal completion of an unsuccessful transaction.
2. Transmit the NACK bit. The collision occurs because the slave address match already took place, and the APIF flag is set to '1' as a result.

Writing a '1' to this bit will clear the COLL flag. The flag is automatically cleared if any Start condition (S/Sr) is detected.

**Note:** The APIF and DIF flags can only generate interrupts whose handlers can be used to check for the collision.

**Bit 2 – BUSERR** Bus Error

The BUSERR flag indicates that an illegal bus operation has occurred. Illegal bus operation is detected if a protocol violating the Start (S), repeated Start (Sr), or Stop (P) conditions is detected on the TWI bus lines. A Start condition directly followed by a Stop condition is one example of a protocol violation. Writing a '1' to this bit will clear the BUSERR flag.

---

The TWI bus error detector is part of the TWI Master circuitry. For the bus errors to be detected by the slave, the TWI Dual mode or the TWI Master must be enabled, and the main clock frequency must be at least four times the SCL frequency. The TWI Dual mode can be enabled by writing '1' to the ENABLE bit in the TWIn.DUALCTRL register. The TWI Master can be enabled by writing '1' to the ENABLE bit in the TWIn.MCTRLA register.

**Bit 1 – DIR** Read/Write Direction

This bit indicates the current TWI bus direction. The DIR bit reflects the direction bit value from the last address packet received from a master TWI device.

When this bit is read as '1', it indicates that a master read operation is in progress.

When this bit is read as '0', it indicates that a master write operation is in progress.

**Bit 0 – AP** Address or Stop

When the TWI slave Address or Stop Interrupt Flag (APIF) is set '1', this bit determines whether the interrupt is due to an address detection or a Stop condition.

Value	Name	Description
0	STOP	A Stop condition generated the interrupt on the APIF flag
1	ADR	Address detection generated the interrupt on the APIF flag



**27.5.13 Slave Address**

**Name:** SADDR  
**Offset:** 0x0C  
**Reset:** 0x00  
**Property:** -

Bit	7	6	5	4	3	2	1	0
	ADDR[7:0]							
Access	R/W	R/W	R/W	R/W	R/W	R/W	R/W	R/W
Reset	0	0	0	0	0	0	0	0

**Bits 7:0 – ADDR[7:0] Address**

The Slave Address (TWIn.SADDR) register is used by the slave address match logic to determine if a master device has addressed the TWI slave. The Address or Stop Interrupt Flag (APIF) and the Address or Stop (AP) bit in the Slave Status (TWIn.SSTATUS) register are set to '1' if an address packet is received.

The upper seven bits (ADDR[7:1]) of the SADDR register represent the main slave address.

The Least Significant bit (ADDR[0]) of the SADDR register is used for the recognition of the General Call Address (0x00) of the I<sup>2</sup>C protocol. This feature is enabled when this bit is set to '1'.

**27.5.14 Slave Data**

**Name:** SDATA  
**Offset:** 0x0D  
**Reset:** 0x00  
**Property:** -

Bit	7	6	5	4	3	2	1	0
	DATA[7:0]							
Access	R/W	R/W	R/W	R/W	R/W	R/W	R/W	R/W
Reset	0	0	0	0	0	0	0	0

**Bits 7:0 – DATA[7:0] Data**

This bit field provides access to the slave data register.

Reading valid data or writing data to be transmitted can only be successfully achieved when the SCL is held low by the slave (i.e., when the slave CLKHOLD bit is set to '1'). It is not necessary to check the Clock Hold (CLKHOLD) bit from the Slave Status (TWIn.SSTATUS) register in software before accessing the SDATA register if the software keeps track of the present protocol state by using interrupts or observing the interrupt flags.

If the Smart Mode Enable (SMEN) bit in the Slave Control A (TWIn.SCTRLA) register is set to '1', a read access to the SDATA register, when the clock hold is active, auto-triggers bus operations and will command the slave to perform an acknowledge action. This is dependent on the setting of the Acknowledge Action (ACKACT) bit from the Slave Control B (TWIn.SCTRLB) register.

**27.5.15 Slave Address Mask**

**Name:** SADDRMASK  
**Offset:** 0x0E  
**Reset:** 0x00  
**Property:** -

Bit	7	6	5	4	3	2	1	0
	ADDRMASK[6:0]							ADDREN
Access	R/W	R/W	R/W	R/W	R/W	R/W	R/W	R/W
Reset	0	0	0	0	0	0	0	0

**Bits 7:1 – ADDRMASK[6:0] Address Mask**

The ADDRMASK bit field acts as a second address match or an address mask register depending on the ADDREN bit.

If the ADDREN bit is written to '0', the ADDRMASK bit field can be loaded with a 7-bit Slave Address mask. Each of the bits in the Slave Address Mask (TWIn.SADDRMASK) register can mask (disable) the corresponding address bits in the TWI Slave Address (TWIn.SADDR) register. When a bit from the mask is written to '1', the address match logic ignores the comparison between the incoming address bit and the corresponding bit in the Slave Address (TWIn.SADDR) register. In other words, masked bits will always match, making it possible to recognize ranges of addresses.

If the ADDREN bit is written to '1', the Slave Address Mask (TWIn.SADDRMASK) register can be loaded with a second slave address in addition to the Slave Address (TWIn.SADDR) register. In this mode, the slave will have two unique addresses, one in the Slave Address (TWIn.SADDR) register and the other one in the Slave Address Mask (TWIn.SADDRMASK) register.

**Bit 0 – ADDREN Address Mask Enable**

If this bit is written to '0', the TWIn.SADDRMASK register acts as a mask to the TWIn.SADDR register.

If this bit is written to '1', the slave address match logic responds to the two unique addresses in slave TWIn.SADDR and TWIn.SADDRMASK.

## 28. CRCSCAN - Cyclic Redundancy Check Memory Scan

### 28.1 Features

- CRC-16-CCITT or CRC-32 (IEEE 802.3)
- Check of the Entire Flash Section, Application Code, and/or Boot Section
- Selectable NMI Trigger on Failure
- User-Configurable Check During Internal Reset Initialization

### 28.2 Overview

The Cyclic Redundancy Check (CRC) is an important safety feature. It scans the Nonvolatile Memory (NVM) making sure the code is correct.

The device will not execute code if Flash fault has occurred. By ensuring no code corruption has occurred, a potentially unintended behavior in the application that can cause a dangerous situation can be avoided. The CRC scan can be set up to scan the entire Flash, only the boot section, or both the boot and application code sections.

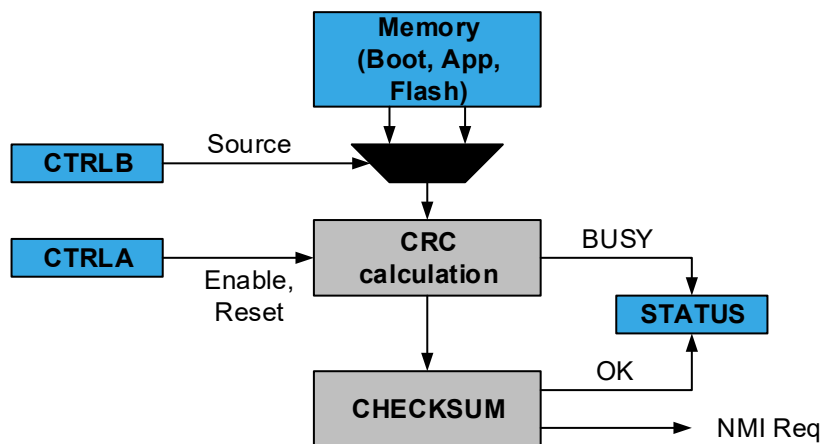
The CRC generates a checksum that is compared to a pre-calculated one. If the two checksums match, the Flash is OK, and the application code can start running.

The BUSY bit in the Status (CRCSCAN.STATUS) register indicates if a CRC scan is ongoing or not, while the OK bit in the Status (CRCSCAN.STATUS) register indicates if the checksum comparison matches or not.

The CRCSCAN can be set up to generate a Non-Maskable Interrupt (NMI) if the checksums do not match.

#### 28.2.1 Block Diagram

Figure 28-1. Cyclic Redundancy Check Block Diagram



### 28.3 Functional Description

#### 28.3.1 Initialization

To enable a CRC in software (or via the debugger):

1. Write the Source (SRC) bit field of the Control B (CRCSCAN.CTRLB) register to select the desired source settings.
2. Enable the CRCSCAN by writing a '1' to the ENABLE bit in the Control A (CRCSCAN.CTRLA) register.
3. The CRC will start after three cycles. The CPU will continue executing during these three cycles.

The selection between CRC32 and CRC16 is done through fuse settings. The CRCSAN can be configured to perform a code memory scan before the device leaves Reset. If this check fails, the CPU is not allowed to start normal code execution. This feature is enabled and controlled by the CRCSRC field in FUSE.SYSCFG0 (see the *Fuses* section for more information).

If the CRCSAN is enabled, a successful CRC check will have the following outcome:

- Normal code execution starts
- The ENABLE bit in CRCSAN.CTRLA will be '1'
- The SRC bit field in CRCSAN.CTRLB will reflect the checked section(s)
- The OK flag in CRCSAN.STATUS will be '1'

If the CRCSAN is enabled, a non-successful CRC check will have the following outcome:

- Normal code execution does not start. The CPU will hang executing no code.
- The ENABLE bit in CRCSAN.CTRLA will be '1'
- The SRC bit field in CRCSAN.CTRLB will reflect the checked section(s)
- The OK flag in CRCSAN.STATUS will be '0'
- This condition may be observed using the debug interface

### 28.3.2 Operation

When operating, the CRCSAN has priority access to the Flash and will stall the CPU until completed.

The CRC will use three clock cycles for each 16-bit fetch. The CRCSAN can be configured to do a scan from start-up.

An  $n$ -bit CRC applied to a data block of arbitrary length will detect any single alteration (error burst) up to  $n$  bits in length. For longer error bursts a fraction  $1-2^{-n}$  will be detected.

The CRC generator supports CRC-16-CCITT and CRC-32 (IEEE 802.3).

The polynomial options are:

- CRC-16-CCITT:  $x^{16} + x^{12} + x^5 + 1$
- CRC-32:  $x^{32} + x^{26} + x^{23} + x^{22} + x^{16} + x^{12} + x^{11} + x^{10} + x^8 + x^7 + x^5 + x^4 + x^2 + x + 1$

The CRC reads byte-by-byte the content of the section(s) it is set up to check, starting with byte 0, and generates a new checksum per byte. The byte is sent through a shift register as depicted below, starting with the Most Significant bit. If the last bytes in the section contain the correct checksum, the CRC will pass. See [28.3.2.1 Checksum](#) for how to place the checksum. The initial value of the Checksum register is 0xFFFF.

#### 28.3.2.1 Checksum

The pre-calculated checksum must be present in the last location of the section to be checked. If the BOOT section is to be checked, the checksum must be saved in the last bytes of the BOOT section. The same is done for APPLICATION and the entire Flash. [Table 28-1](#) shows explicitly how the checksum must be stored for the different sections. Refer to the CRCSAN.CTRLB register description for how to configure the sections to be checked.

**Table 28-1. Placement of the Pre-Calculated Checksum for CRC16 in Flash**

Section to Check	CHECKSUM[15:8]	CHECKSUM[7:0]
BOOT	BOOTEND-1	BOOTEND
BOOT and APPLICATION	APPEND-1	APPEND
Full Flash	FLASHEND-1	FLASHEND

**Table 28-2. Placement of the Pre-Calculated Checksum for CRC32 in Flash**

Section to Check	CHECKSUM[31:24]	CHECKSUM[23:16]	CHECKSUM[15:8]	CHECKSUM[7:0]
BOOT	BOOTEND	BOOTEND-1	BOOTEND-2	BOOTEND-3
BOOT and APPLICATION	APPEND	APPEND-1	APPEND-2	APPEND-3
Full Flash	FLASHEND	FLASHEND-1	FLASHEND-2	FLASHEND-3

### 28.3.3 Interrupts

**Table 28-3. Available Interrupt Vectors and Sources**

Name	Vector Description	Conditions
NMI	Non-Maskable Interrupt	CRC failure

When the interrupt condition occurs the OK flag in the Status (CRCSCAN.STATUS) register is cleared to '0'.

A Non-Maskable Interrupt (NMI) is enabled by writing a '1' to the respective Enable (NMIEN) bit in the Control A (CRCSCAN.CTRLA) register, but can only be disabled with a System Reset. An NMI is generated when the OK flag in the CRCSCAN.STATUS register is cleared, and the NMIEN bit is '1'. The NMI request remains active until a System Reset and cannot be disabled.

An NMI can be triggered even if interrupts are not globally enabled.

### 28.3.4 Sleep Mode Operation

In all CPU sleep modes, the CRCSCAN is halted and will resume operation when the CPU wakes up.

The CRCSCAN starts operation three cycles after writing the Enable (ENABLE) bit in the Control A (CRCSCAN.CTRLA) register. During these three cycles, it is possible to enter sleep mode. In this case:

1. The CRCSCAN will not start until the CPU is woken up.
2. Any interrupt handler will execute after CRCSCAN has finished.

### 28.3.5 Debug Operation

Whenever the debugger reads or writes a peripheral or memory location, the CRCSCAN will be disabled.

If the CRCSCAN is busy when the debugger accesses the device, the CRCSCAN will restart the ongoing operation when the debugger accesses an internal register or when the debugger disconnects.

The BUSY bit in the Status (CRCSCAN.STATUS) register will read '1' if the CRCSCAN was busy when the debugger caused it to disable, but it will not actively check any section as long as the debugger keeps it disabled. There are synchronized CRC status bits in the debugger's internal register space, which can be read by the debugger without disabling the CRCSCAN. Reading the debugger's internal CRC status bits will make sure that the CRCSCAN is enabled.

It is possible to write the CRCSCAN.STATUS register directly from the debugger:

- BUSY bit in CRCSCAN.STATUS:
  - Writing the BUSY bit to '0' will stop the ongoing CRC operation (so that the CRCSCAN does not restart its operation when the debugger allows it).
  - Writing the BUSY bit to '1' will make the CRC start a single check with the settings in the Control B (CRCSCAN.CTRLB) register, but not until the debugger allows it.

As long as the BUSY bit in CRCSCAN.STATUS is '1', CRCSCAN.CTRLB and the Non-Maskable Interrupt Enable (NMIEN) bit in the Control A (CRCSCAN.CTRLA) register cannot be altered.

- OK bit in CRCSCAN.STATUS:
  - Writing the OK bit to '0' can trigger a Non-Maskable Interrupt (NMI) if the NMIEN bit in CRCSCAN.CTRLA is '1'. If an NMI has been triggered, no writes to the CRCSCAN are allowed.
  - Writing the OK bit to '1' will make the OK bit read as '1' when the BUSY bit in CRCSCAN.STATUS is '0'.

Writes to CRCSCAN.CTRLA and CRCSCAN.CTRLB from the debugger are treated in the same way as writes from the CPU.

## 28.4 Register Summary

Offset	Name	Bit Pos.	7	6	5	4	3	2	1	0
0x00	<a href="#">CTRLA</a>	7:0	RESET						NMIEN	ENABLE
0x01	<a href="#">CTRLB</a>	7:0							SRC[1:0]	
0x02	<a href="#">STATUS</a>	7:0							OK	BUSY

## 28.5 Register Description

## 28.5.1 Control A

**Name:** CTRLA  
**Offset:** 0x00  
**Reset:** 0x00  
**Property:** -

If an NMI has been triggered this register is not writable.

Bit	7	6	5	4	3	2	1	0
	RESET						NMIEN	ENABLE
Access	R/W						R/W	R/W
Reset	0						0	0

**Bit 7 – RESET** Reset CRCSCAN

Writing this bit to '1' resets the CRCSCAN. The CRCSCAN Control and Status (CRCSCAN.CTRLA, CRCSCAN.CTRLB, CRCSCAN.STATUS) register will be cleared one clock cycle after the RESET bit is written to '1'. If NMIEN is '0', this bit is writable both when the CRCSCAN is busy (the BUSY bit in CRCSCAN.STATUS is '1') and not busy (the BUSY bit is '0'), and will take effect immediately. If NMIEN is '1', this bit is only writable when the CRCSCAN is not busy (the BUSY bit in CRCSCAN.STATUS is '0'). The RESET bit is a strobe bit.

**Bit 1 – NMIEN** Enable NMI Trigger

When this bit is written to '1', any CRC failure will trigger an NMI. This bit can only be cleared by a System Reset. It is not cleared by a write to the RESET bit. This bit can only be written to '1' when the CRCSCAN is not busy (the BUSY bit in CRCSCAN.STATUS is '0').

**Bit 0 – ENABLE** Enable CRCSCAN

Writing this bit to '1' enables the CRCSCAN with the current settings. It will stay '1' even after a CRC check has completed, but writing it to '1' again will start a new check.

Writing the bit to '0' has no effect.

The CRCSCAN can be configured to run a scan during the microcontroller (MCU) start-up sequence to verify the Flash sections before letting the CPU start normal code execution (see the [28.3.1 Initialization](#) section). If this feature is enabled, the ENABLE bit will read as '1' when normal code execution starts.

To see whether the CRCSCAN is busy with an ongoing check, poll the BUSY bit in the Status (CRCSCAN.STATUS) register.



### 28.5.2 Control B

**Name:** CTRLB  
**Offset:** 0x01  
**Reset:** 0x00  
**Property:** -

The Control B register contains the source settings for the CRC. It is not writable when the CRCSCAN is busy, or when an NMI has been triggered.

	7	6	5	4	3	2	1	0
							SRC[1:0]	
Access							R/W	R/W
Reset							0	0

#### Bits 1:0 – SRC[1:0] CRC Source

The SRC bit field selects which section of the Flash will be checked by the CRCSCAN. To set up section sizes, refer to the *Fuses* section.

The CRCSCAN can be enabled during internal Reset initialization to verify Flash sections before letting the CPU start (see the *Fuses* section). If the CRCSCAN is enabled during internal Reset initialization, the SRC bit field will read out as FLASH, BOOTAPP, or BOOT when normal code execution starts (depending on the configuration).

Value	Name	Description
0x0	FLASH	The CRC is performed on the entire Flash (boot, application code, and application data sections)
0x1	BOOTAPP	The CRC is performed on the boot and application code sections of Flash
0x2	BOOT	The CRC is performed on the boot section of Flash
0x3	-	Reserved

28.5.3 Status

**Name:** STATUS  
**Offset:** 0x02  
**Reset:** 0x02  
**Property:** -

Bit	7	6	5	4	3	2	1	0
							OK	BUSY
Access							R	R
Reset							1	0

**Bit 1 – OK** CRC OK

When this bit is read as '1', the previous CRC completed successfully. The bit is set to '1' by default before a CRC scan is run. The bit is not valid unless BUSY is '0'.

**Bit 0 – BUSY** CRC Busy

When this bit is read as '1', the CRCSCAN is busy. As long as the module is busy, the access to the control registers is limited.

## 29. CCL – Configurable Custom Logic

### 29.1 Features

- Glue Logic for General Purpose PCB Design
- 6 Programmable Look-Up Tables (LUTs)
- Combinatorial Logic Functions: Any Logic Expression which is a Function of up to Three Inputs.
- Sequencer Logic Functions:
  - Gated D flip-flop
  - JK flip-flop
  - Gated D latch
  - RS latch
- Flexible LUT Input Selection:
  - I/Os
  - Events
  - Subsequent LUT output
  - Internal peripherals such as:
    - Analog comparator
    - Timers/Counters
    - USART
    - SPI
- Clocked by a System Clock or other Peripherals
- Output can be Connected to I/O Pins or an Event System
- Optional Synchronizer, Filter, or Edge Detector Available on Each LUT Output
- Optional Interrupt Generation from Each LUT Output:
  - Rising edge
  - Falling edge
  - Both edges

### 29.2 Overview

The Configurable Custom Logic (CCL) is a programmable logic peripheral which can be connected to the device pins, to events, or to other internal peripherals. The CCL can serve as 'glue logic' between the device peripherals and external devices. The CCL can eliminate the need for external logic components, and can also help the designer to overcome real-time constraints by combining Core Independent Peripherals (CIPs) to handle the most time-critical parts of the application independent of the CPU.

The CCL peripheral provides a number of Look-up Tables (LUTs). Each LUT consists of three inputs, a truth table, a synchronizer/filter, and an edge detector. Each LUT can generate an output as a user programmable logic expression with three inputs. The output is generated from the inputs using the combinatorial logic and can be filtered to remove spikes. The CCL can be configured to generate an interrupt request on changes in the LUT outputs.

Neighboring LUTs can be combined to perform specific operations. A sequencer can be used for generating complex waveforms.

### 29.2.1 Block Diagram

Figure 29-1. Configurable Custom Logic

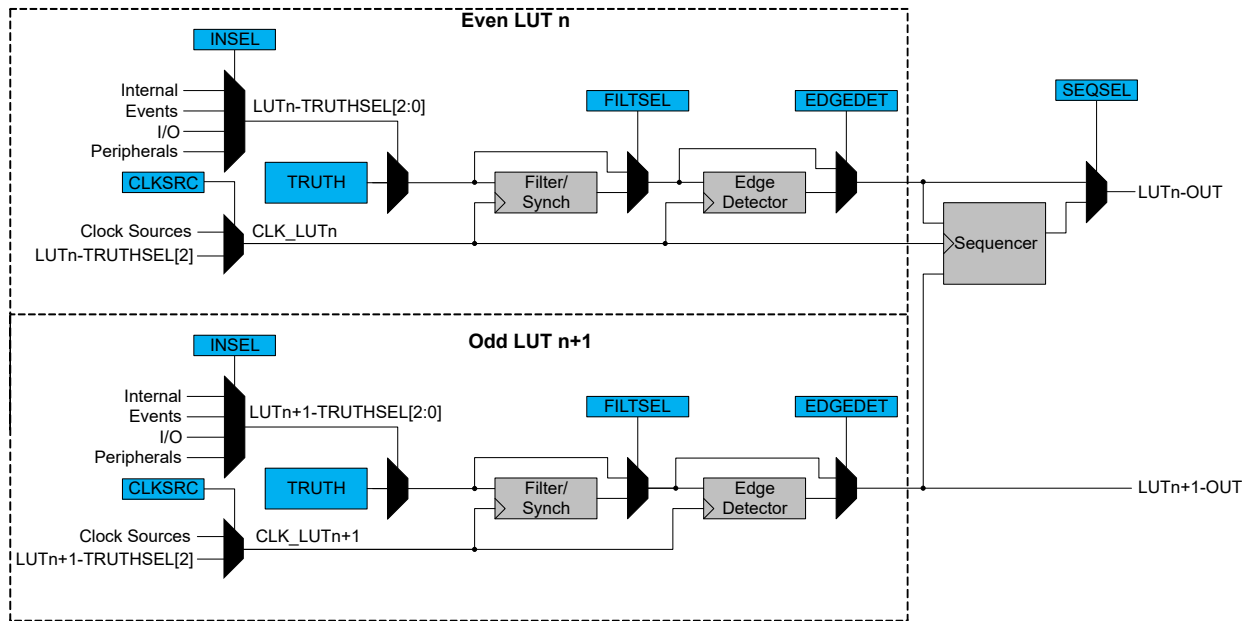


Table 29-2. Sequencer and LUT Connection

Sequencer	Even and Odd LUT
SEQ0	LUT0 and LUT1
SEQ1	LUT2 and LUT3
SEQ2	LUT4 and LUT5

### 29.2.2 Signal Description

Name	Type	Description
LUTn-OUT	Digital output	Output from the look-up table
LUTn-IN[2:0]	Digital input	Input to the look-up table. LUTn-IN[2] can serve as CLK_LUTn.

Refer to *I/O Multiplexing and Considerations* for details on the pin mapping for this peripheral. One signal can be mapped to several pins.

#### 29.2.2.1 CCL Input Selection MUX

The following peripherals outputs are available as inputs into the CCL LUT.

Value	Input source	INSEL0[3:0]	INSEL1[3:0]	INSEL2[3:0]
0x00	MASK		None	
0x01	FEEDBACK		LUTn	
0x02	LINK		LUT[n+1]	
0x03	EVENTA		EVENTA	
0x04	EVENTB		EVENTB	
0x05	IO	IN0	IN1	IN2

.....continued				
Value	Input source	INSEL0[3:0]	INSEL1[3:0]	INSEL2[3:0]
0x06	AC	AC0 OUT	AC1 OUT	AC2 OUT
0x07	ZCD	ZCD0 OUT	ZCD1 OUT	ZCD2 OUT
0x08	USART	USART0 TXD	USART1 TXD	USART2 TXD
0x09	SPI	SPI0 MOSI	SPI0 MOSI	SPI0 SCK
0x0A	TCA0	WO0	WO1	WO2
0x0B	TCA1	WO0	WO1	WO2
0x0C	TCB	TCB0 WO	TCB1 WO	TCB2 WO
0x0D	TCD0	WOA	WOB	WOC
0x0E-0x0F	Reserved			

**Notes:**

- SPI connections to the CCL work only in master SPI mode
- USART connections to the CCL work only in asynchronous/synchronous USART master mode

## 29.3 Functional Description

### 29.3.1 Operation

#### 29.3.1.1 Enable-Protected Configuration

The configuration of the LUTs and sequencers is enable-protected, meaning that they can only be configured when the corresponding even LUT is disabled (ENABLE=0 in the LUT n Control A register, CCL.LUTnCTRLA). This is a mechanism to suppress the undesired output from the CCL under (re-)configuration.

The following bits and registers are enable-protected:

- Sequencer Selection (SEQSEL) in the Sequencer Control n register (CCL.SEQCTRLn)
- LUT n Control x registers (CCL.LUTnCTRLx), except the ENABLE bit in CCL.LUTnCTRLA

The enable-protected bits in the CCL.LUTnCTRLx registers can be written at the same time as ENABLE in CCL.LUTnCTRLA is written to '1', but not at the same time as ENABLE is written to '0'.

The enable protection is denoted by the enable-protected property in the register description.

#### 29.3.1.2 Enabling, Disabling, and Resetting

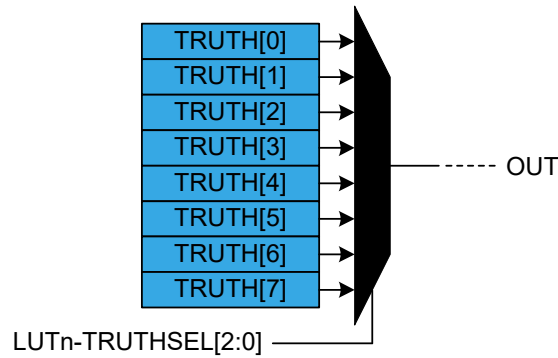
The CCL is enabled by writing a '1' to the ENABLE bit in the Control register (CCL.CTRLA). The CCL is disabled by writing a '0' to that ENABLE bit.

Each LUT is enabled by writing a '1' to the LUT Enable bit (ENABLE) in the LUT n Control A register (CCL.LUTnCTRLA). Each LUT is disabled by writing a '0' to the ENABLE bit in CCL.LUTnCTRLA.

#### 29.3.1.3 Truth Table Logic

The truth table in each LUT unit can generate a combinational logic output as a function of up to three inputs (LUTn-TRUTHSEL[2:0]). The unused inputs can be turned off (tied low). The truth table for the combinational logic expression is defined by the bits in the CCL.TRUTHn registers. Each combination of the input bits (LUTn-TRUTHSEL[2:0]) corresponds to one bit in the TRUTHn register, as shown in the table below.

**Figure 29-2. Truth Table Output Value Selection of a LUT**



**Table 29-3. Truth Table of a LUT**

LUTn-TRUTHSEL[2]	LUTn-TRUTHSEL[1]	LUTn-TRUTHSEL[0]	OUT
0	0	0	TRUTH[0]
0	0	1	TRUTH[1]
0	1	0	TRUTH[2]
0	1	1	TRUTH[3]
1	0	0	TRUTH[4]
1	0	1	TRUTH[5]
1	1	0	TRUTH[6]
1	1	1	TRUTH[7]

### 29.3.1.4 Truth Table Inputs Selection

#### Input Overview

The inputs can be individually:

- OFF
- Driven by peripherals
- Driven by internal events from the Event System
- Driven by I/O pin inputs
- Driven by other LUTs

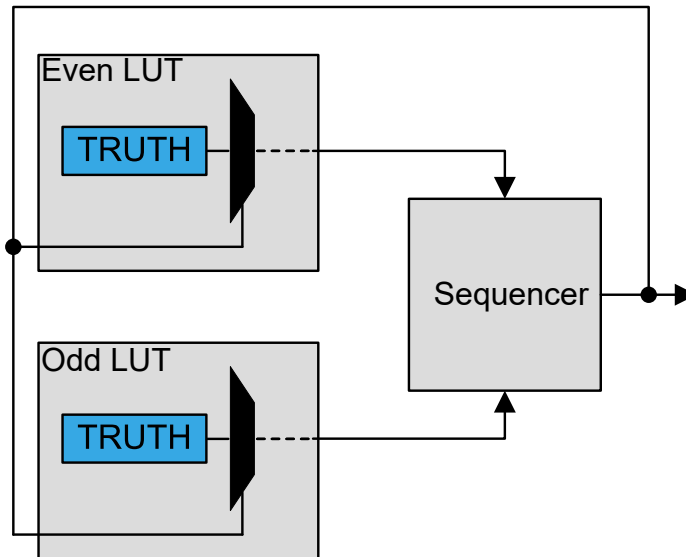
The input for each LUT is configured by writing the Input Source Selection bits in the LUT Control registers:

- INSEL0 in CCL.LUTnCTRLB
- INSEL1 in CCL.LUTnCTRLB
- INSEL2 in CCL.LUTnCTRLC

#### Internal Feedback Inputs (FEEDBACK)

The output from a sequencer can be used as an input source for the two LUTs it is connected to.

Figure 29-3. Feedback Input Selection



When selected (INSELy=FEEDBACK in LUTnCTRLx), the sequencer (SEQ) output is used as input for the corresponding LUTs.

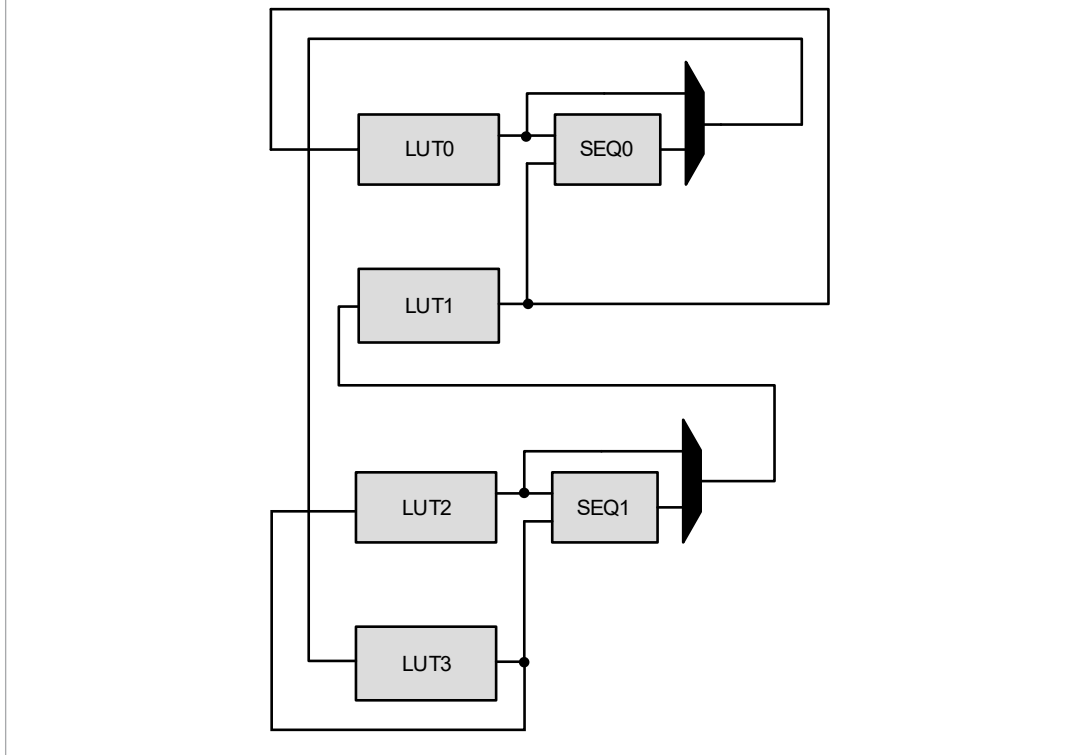
#### Linked LUT (LINK)

When selecting the LINK input option, the next LUT's direct output is used as LUT input. In general, LUT[n+1] is linked to the input of LUT[n]. LUT0 is linked to the input of the last LUT.

#### Example 29-1. Linking all LUTs on a Device with Four LUTs

- LUT1 is the input for LUT0
- LUT2 is the input for LUT1
- LUT3 is the input for LUT2
- LUT0 is the input for LUT3 (wrap-around)

Figure 29-4. Linked LUT Input Selection



#### Event Input Selection (EVENTx)

Events from the Event System can be used as inputs to the LUTs by writing to the INSELn bit groups in the LUT n Control B and C registers.

#### I/O Pin Inputs (IO)

When selecting the IO option, the LUT input will be connected to its corresponding I/O pin. Refer to the I/O Multiplexing section in the data sheet for more details about where the LUTn-INy pins are located.

#### Peripherals

The different peripherals on the three input lines of each LUT are selected by writing to the Input Select (INSEL) bits in the LUT Control registers (LUTnCTRLB and LUTnCTRLC).

#### 29.3.1.5 Filter

By default, the LUT output is a combinational function of the LUT inputs. This may cause some short glitches when the inputs change the value. These glitches can be removed by clocking through filters if demanded by application needs.

The Filter Selection bits (FILTSEL) in the LUT n Control A registers (CCL.LUTnCTRLA) define the digital filter options.

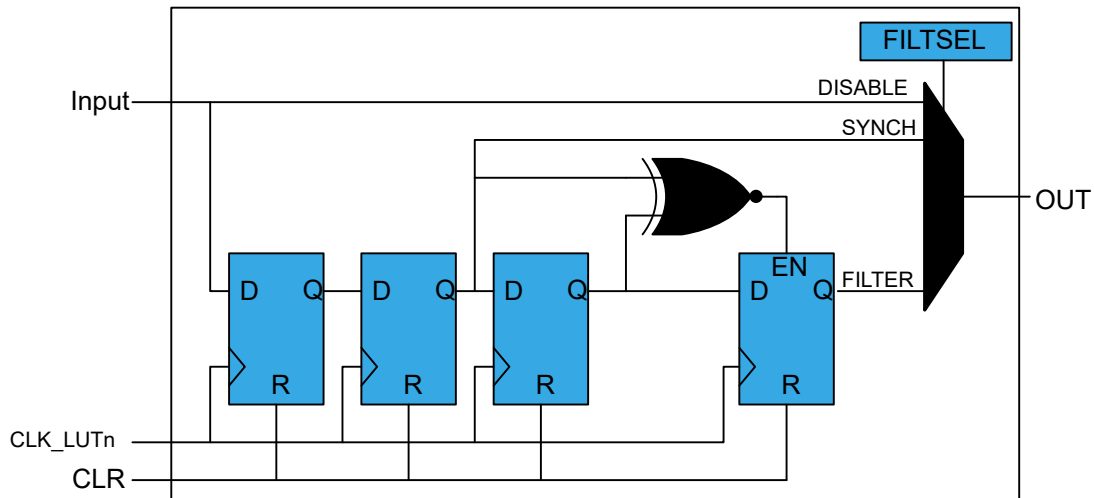
When FILTSEL=SYNCH, the output is synchronized with CLK\_LUTn. The output will be delayed by two positive CLK\_LUTn edges.

When FILTSEL=FILTER, only the input that is persistent for more than two positive CLK\_LUTn edges will pass through the gated flip-flop to the output. The output will be delayed by four positive CLK\_LUTn edges.

One clock cycle later, after the corresponding LUT is disabled, all internal filter logic is cleared.



Figure 29-5. Filter



### 29.3.1.6 Edge Detector

The edge detector can be used to generate a pulse when detecting a rising edge on its input. To detect a falling edge, the TRUTH table can be programmed to provide inverted output.

The edge detector is enabled by writing '1' to the Edge Detection bit (EDGEDET) in the LUT n Control A register (CCL.LUTnCTRLA). In order to avoid unpredictable behavior, a valid filter option must be enabled.

The edge detection is disabled by writing a '0' to EDGEDET in CCL.LUTnCTRLA. After disabling a LUT, the corresponding internal edge detector logic is cleared one clock cycle later.

Figure 29-6. Edge Detector



### 29.3.1.7 Sequencer Logic

Each LUT pair can be connected to a sequencer. The sequencer can function as either D flip-flop, JK flip-flop, gated D latch, or RS latch. The function is selected by writing the Sequencer Selection (SEQSEL) bit group in the Sequencer Control register (CCL.SEQCTRLn).

The sequencer receives its input from either the LUT, filter or edge detector, depending on the configuration.

A sequencer is clocked by the same clock as the corresponding even LUT. The clock source is selected by the Clock Source (CLKSRC) bit group in the LUT n Control A register (CCL.LUTnCTRLA).

The flip-flop output (OUT) is refreshed on the rising edge of the clock. When the even LUT is disabled, the latch is cleared asynchronously. The flip-flop Reset signal (R) is kept enabled for one clock cycle.

#### Gated D Flip-Flop (DFF)

The D input is driven by the even LUT output, and the G input is driven by the odd LUT output.

Figure 29-7. D Flip-Flop

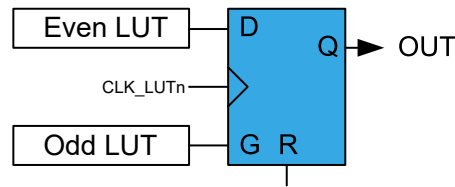


Table 29-4. DFF Characteristics

R	G	D	OUT
1	X	X	Clear
0	1	1	Set
0	1	0	Clear
0	0	X	Hold state (no change)

### JK Flip-Flop (JK)

The J input is driven by the even LUT output, and the K input is driven by the odd LUT output.

Figure 29-8. JK Flip-Flop

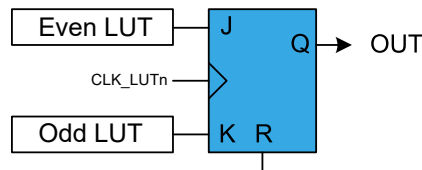


Table 29-5. JK Characteristics

R	J	K	OUT
1	X	X	Clear
0	0	0	Hold state (no change)
0	0	1	Clear
0	1	0	Set
0	1	1	Toggle

### Gated D Latch (DLATCH)

The D input is driven by the even LUT output, and the G input is driven by the odd LUT output.

Figure 29-9. D Latch

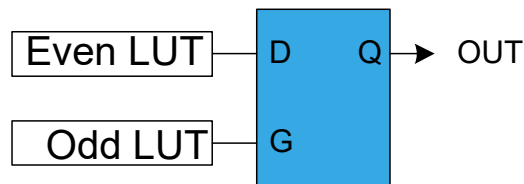


Table 29-6. D Latch Characteristics

G	D	OUT
0	X	Hold state (no change)
1	0	Clear

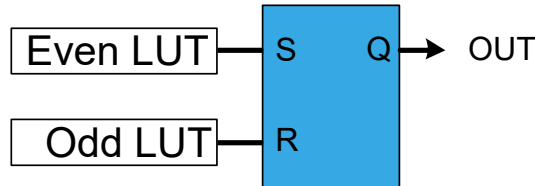
.....continued

G	D	OUT
1	1	Set

**RS Latch (RS)**

The S input is driven by the even LUT output, and the R input is driven by the odd LUT output.

**Figure 29-10. RS Latch**



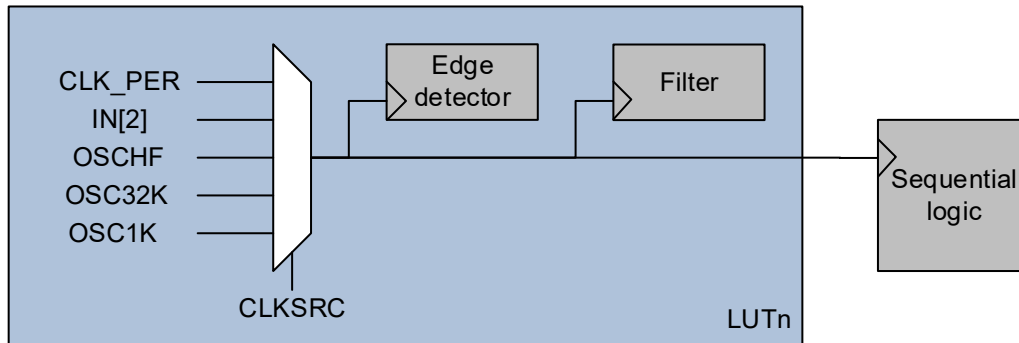
**Table 29-7. RS Latch Characteristics**

S	R	OUT
0	0	Hold state (no change)
0	1	Clear
1	0	Set
1	1	Forbidden state

**29.3.1.8 Clock Source Settings**

The filter, edge detector, and sequencer are, by default, clocked by the peripheral clock (CLK\_PER). It is also possible to use other clock inputs (CLK\_LUTn) to clock these blocks. This is configured by writing the Clock Source (CLKSRC) bits in the LUT Control A register.

**Figure 29-11. Clock Source Settings**



When the Clock Source (CLKSRC) bit is written to 0x1, LUTn-TRUTHSEL[2] is used to clock the corresponding filter and edge detector (CLK\_LUTn). The sequencer is clocked by the CLK\_LUTn of the even LUT in the pair. When CLKSRC is written to 0x1, LUTn-TRUTHSEL[2] is treated as OFF (low) in the TRUTH table.

The CCL peripheral must be disabled while changing the clock source to avoid undefined outputs from the peripheral.

**29.3.2 Interrupts**

**Table 29-8. Available Interrupt Vectors and Sources**

Name	Vector Description	Conditions
CCL	CCL interrupt	INTn in INTFLAG is raised as configured by the INTMODEn bits in the CCL.INTCTRLn register

When an interrupt condition occurs, the corresponding interrupt flag is set in the peripheral's Interrupt Flags (*peripheral.INTFLAGS*) register.

An interrupt source is enabled or disabled by writing to the corresponding enable bit in the peripheral's Interrupt Control (*peripheral.INTCTRL*) register.

An interrupt request is generated when the corresponding interrupt source is enabled, and the interrupt flag is set. The interrupt request remains active until the interrupt flag is cleared. See the peripheral's INTFLAGS register for details on how to clear interrupt flags.

When several interrupt request conditions are supported by an interrupt vector, the interrupt requests are ORed together into one combined interrupt request to the interrupt controller. The user must read the peripheral's INTFLAGS register to determine which of the interrupt conditions are present.

### 29.3.3 Events

The CCL can generate the events shown in the table below.

**Table 29-9. Event Generators in the CCL**

Generator Name		Description	Event Type	Generating Clock Domain	Length of Event
Peripheral	Event				
CCL	LUTn	LUT output level	Level	Asynchronous	Depends on the CCL configuration

The CCL has the event users below for detecting and acting upon input events.

**Table 29-10. Event Users in the CCL**

User Name		Description	Input Detection	Async/Sync
Peripheral	Input			
CCL	LUTnx	LUTn input x or clock signal	No detection	Async

The event signals are passed directly to the LUTs without synchronization or input detection logic.

Two event users are available for each LUT. They can be selected as LUTn inputs by writing to the INSELn bit groups in the LUT n Control B and Control C registers (CCL.LUTnCTRLB or LUTnCTRLC).

Refer to the Event System (EVSYS) section for more details regarding the event types and the EVSYS configuration.

### 29.3.4 Sleep Mode Operation

Writing the Run In Standby bit (RUNSTDBY) in the Control A register (CCL.CTRLA) to '1' will allow the selected clock source to be enabled in Standby sleep mode.

If RUNSTDBY is '0' the peripheral clock will be disabled in Standby sleep mode. If the filter, edge detector, and/or sequencer are enabled, the LUT output will be forced to '0' in Standby sleep mode. In Idle sleep mode, the TRUTH table decoder will continue the operation and the LUT output will be refreshed accordingly, regardless of the RUNSTDBY bit.

If the Clock Source bit (CLKSRC) in the LUT n Control A register (CCL.LUTnCTRLA) is written to '1', the LUTn-TRUTHSEL[2] will always clock the filter, edge detector, and sequencer. The availability of the LUTn-TRUTHSEL[2] clock in sleep modes will depend on the sleep settings of the peripheral used.

## 29.4 Register Summary

Offset	Name	Bit Pos.	7	6	5	4	3	2	1	0
0x00	<a href="#">CTRLA</a>	7:0		RUNSTDBY						ENABLE
0x01	<a href="#">SEQCTRL0</a>	7:0						SEQSEL0[3:0]		
0x02	<a href="#">SEQCTRL1</a>	7:0						SEQSEL1[3:0]		
0x03	<a href="#">SEQCTRL2</a>	7:0						SEQSEL2[3:0]		
0x04	Reserved									
0x05	<a href="#">INTCTRL0</a>	7:0	INTMODE3[1:0]		INTMODE2[1:0]		INTMODE1[1:0]		INTMODE0[1:0]	
0x06	<a href="#">INTCTRL1</a>	7:0					INTMODE5[1:0]		INTMODE4[1:0]	
0x07	<a href="#">INTFLAGS</a>	7:0			INT5	INT4	INT3	INT2	INT1	INT0
0x08	<a href="#">LUT0CTRLA</a>	7:0	EDGEDET	OUTEN	FILTSEL[1:0]		CLKSRC[2:0]			ENABLE
0x09	<a href="#">LUT0CTRLB</a>	7:0			INSEL1[3:0]			INSEL0[3:0]		
0x0A	<a href="#">LUT0CTRLC</a>	7:0						INSEL2[3:0]		
0x0B	<a href="#">TRUTH0</a>	7:0					TRUTH[7:0]			
0x0C	<a href="#">LUT1CTRLA</a>	7:0	EDGEDET	OUTEN	FILTSEL[1:0]		CLKSRC[2:0]			ENABLE
0x0D	<a href="#">LUT1CTRLB</a>	7:0			INSEL1[3:0]			INSEL0[3:0]		
0x0E	<a href="#">LUT1CTRLC</a>	7:0						INSEL2[3:0]		
0x0F	<a href="#">TRUTH1</a>	7:0					TRUTH[7:0]			
0x10	<a href="#">LUT2CTRLA</a>	7:0	EDGEDET	OUTEN	FILTSEL[1:0]		CLKSRC[2:0]			ENABLE
0x11	<a href="#">LUT2CTRLB</a>	7:0			INSEL1[3:0]			INSEL0[3:0]		
0x12	<a href="#">LUT2CTRLC</a>	7:0						INSEL2[3:0]		
0x13	<a href="#">TRUTH2</a>	7:0					TRUTH[7:0]			
0x14	<a href="#">LUT3CTRLA</a>	7:0	EDGEDET	OUTEN	FILTSEL[1:0]		CLKSRC[2:0]			ENABLE
0x15	<a href="#">LUT3CTRLB</a>	7:0			INSEL1[3:0]			INSEL0[3:0]		
0x16	<a href="#">LUT3CTRLC</a>	7:0						INSEL2[3:0]		
0x17	<a href="#">TRUTH3</a>	7:0					TRUTH[7:0]			
0x18	<a href="#">LUT4CTRLA</a>	7:0	EDGEDET	OUTEN	FILTSEL[1:0]		CLKSRC[2:0]			ENABLE
0x19	<a href="#">LUT4CTRLB</a>	7:0			INSEL1[3:0]			INSEL0[3:0]		
0x1A	<a href="#">LUT4CTRLC</a>	7:0						INSEL2[3:0]		
0x1B	<a href="#">TRUTH4</a>	7:0					TRUTH[7:0]			
0x1C	<a href="#">LUT5CTRLA</a>	7:0	EDGEDET	OUTEN	FILTSEL[1:0]		CLKSRC[2:0]			ENABLE
0x1D	<a href="#">LUT5CTRLB</a>	7:0			INSEL1[3:0]			INSEL0[3:0]		
0x1E	<a href="#">LUT5CTRLC</a>	7:0						INSEL2[3:0]		
0x1F	<a href="#">TRUTH5</a>	7:0					TRUTH[7:0]			

## 29.5 Register Description

**29.5.1 Control A**

**Name:** CTRLA  
**Offset:** 0x00  
**Reset:** 0x00  
**Property:** -

	Bit	7	6	5	4	3	2	1	0
			RUNSTDBY						ENABLE
Access			R/W						R/W
Reset			0						0

**Bit 6 – RUNSTDBY** Run in Standby

Writing this bit to '1' will enable the peripheral to run in Standby sleep mode.

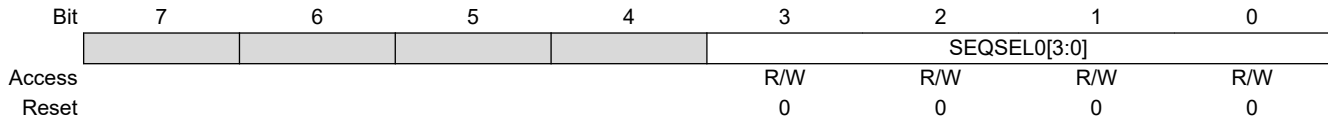
Value	Description
0	The CCL will not run in Standby sleep mode
1	The CCL will run in Standby sleep mode

**Bit 0 – ENABLE** Enable

Value	Description
0	The peripheral is disabled
1	The peripheral is enabled

### 29.5.2 Sequencer Control 0

**Name:** SEQCTRL0  
**Offset:** 0x01  
**Reset:** 0x00  
**Property:** Enable-Protected



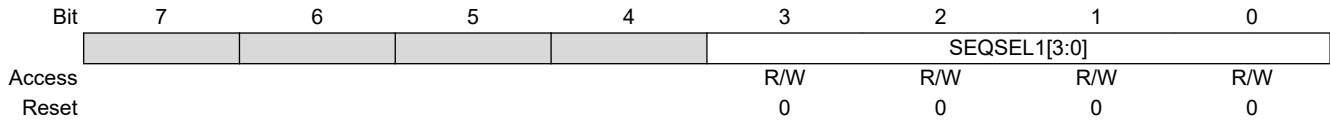
**Bits 3:0 – SEQSEL0[3:0]** Sequencer Selection

This bit group selects the sequencer configuration for LUT0 and LUT1.

Value	Name	Description
0x0	DISABLE	The sequencer is disabled
0x1	DFF	D flip-flop
0x2	JK	JK flip-flop
0x3	LATCH	D latch
0x4	RS	RS latch
Other	-	Reserved

**29.5.3 Sequencer Control 1**

**Name:** SEQCTRL1  
**Offset:** 0x02  
**Reset:** 0x00  
**Property:** Enable-Protected



**Bits 3:0 – SEQSEL1[3:0] Sequencer Selection**

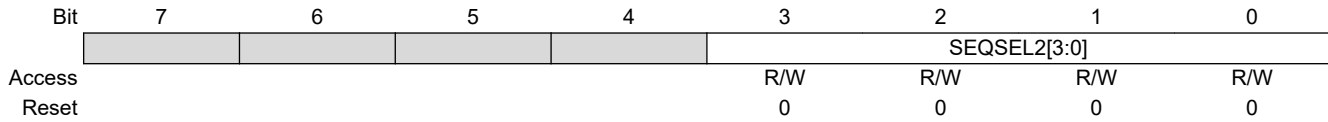
This bit group selects the sequencer configuration for LUT2 and LUT3.

Value	Name	Description
0x0	DISABLE	The sequencer is disabled
0x1	DFF	D flip-flop
0x2	JK	JK flip-flop
0x3	LATCH	D latch
0x4	RS	RS latch
Other	-	Reserved



### 29.5.4 Sequencer Control 2

**Name:** SEQCTRL2  
**Offset:** 0x03  
**Reset:** 0x00  
**Property:** Enable-Protected



**Bits 3:0 – SEQSEL2[3:0]** Sequencer Selection

This bit group selects the sequencer configuration for LUT4 and LUT5.

Value	Name	Description
0x0	DISABLE	The sequencer is disabled
0x1	DFF	D flip-flop
0x2	JK	JK flip-flop
0x3	LATCH	D latch
0x4	RS	RS latch
Other	-	Reserved

### 29.5.5 Interrupt Control 0

**Name:** INTCTRL0  
**Offset:** 0x05  
**Reset:** 0x00  
**Property:** -

Bit	7	6	5	4	3	2	1	0
	INTMODE3[1:0]		INTMODE2[1:0]		INTMODE1[1:0]		INTMODE0[1:0]	
Access	R/W	R/W	R/W	R/W	R/W	R/W	R/W	R/W
Reset	0	0	0	0	0	0	0	0

#### Bits 0:1, 2:3, 4:5, 6:7 – INTMODE

The bits in INTMODEn select the interrupt sense configuration for LUTn-OUT.

Value	Name	Description
0x0	INTDISABLE	Interrupt disabled
0x1	RISING	Sense rising edge
0x2	FALLING	Sense falling edge
0x3	BOTH	Sense both edges

### 29.5.6 Interrupt Control 1

**Name:** INTCTRL1  
**Offset:** 0x06  
**Reset:** 0x00  
**Property:** -

	7	6	5	4	3	2	1	0
					INTMODE5[1:0]		INTMODE4[1:0]	
Access					R/W	R/W	R/W	R/W
Reset					0	0	0	0

#### Bits 0:1, 2:3 – INTMODE

The bits in INTMODEn select the interrupt sense configuration for LUTn-OUT.

Value	Name	Description
0x0	INTDISABLE	Interrupt disabled
0x1	RISING	Sense rising edge
0x2	FALLING	Sense falling edge
0x3	BOTH	Sense both edges

**29.5.7 Interrupt Flag**

**Name:** INTFLAGS  
**Offset:** 0x07  
**Reset:** 0x00  
**Property:** -

	7	6	5	4	3	2	1	0
Bit			INT5	INT4	INT3	INT2	INT1	INT0
Access			R/W	R/W	R/W	R/W	R/W	R/W
Reset			0	0	0	0	0	0

**Bits 0, 1, 2, 3, 4, 5 – INT** Interrupt Flag

The INTn flag is set when the LUTn output change matches the Interrupt Sense mode as defined in CCL.INTCTRLn. Writing a '1' to this flag's bit location will clear the flag.

### 29.5.8 LUT n Control A

**Name:** LUTnCTRLA  
**Offset:** 0x08 + n\*0x04 [n=0..5]  
**Reset:** 0x00  
**Property:** Enable-Protected

Bit	7	6	5	4	3	2	1	0
	EDGEDET	OUTEN	FILTSEL[1:0]			CLKSRC[2:0]		ENABLE
Access	R/W	R/W	R/W	R/W	R/W	R/W	R/W	R/W
Reset	0	0	0	0	0	0	0	0

#### Bit 7 – EDGEDET Edge Detection

Value	Description
0	Edge detector is disabled
1	Edge detector is enabled

#### Bit 6 – OUTEN Output Enable

This bit enables the LUT output to the LUTn OUT pin. When written to '1', the pin configuration of the PORT I/O-Controller is overridden.

Value	Description
0	Output to pin disabled
1	Output to pin enabled

#### Bits 5:4 – FILTSEL[1:0] Filter Selection

These bits select the LUT output filter options.

Value	Name	Description
0x0	DISABLE	Filter disabled
0x1	SYNCH	Synchronizer enabled
0x2	FILTER	Filter enabled
0x3	-	Reserved

#### Bits 3:1 – CLKSRC[2:0] Clock Source Selection

This bit selects between various clock sources to be used as the clock (CLK\_LUTn) for a LUT. The CLK\_LUTn of the even LUT is used for clocking the sequencer of a LUT pair.

Value	Input Source	Description
0x0	CLKPER	CLK_PER is clocking the LUT
0x1	IN2	IN2 is clocking the LUT
0x2	-	Reserved
0x3	-	Reserved
0x4	OSCHF	Internal high-frequency oscillator before prescaler is clocking LUT
0x5	OSC32K	Internal 32.786 kHz oscillator
0x6	OSC1K	Internal 32.768 kHz oscillator divided by 32
0x07	-	Reserved

#### Bit 0 – ENABLE LUT Enable

Value	Description
0	The LUT is disabled
1	The LUT is enabled

### 29.5.9 LUT n Control B

**Name:** LUTnCTRLB  
**Offset:** 0x09 + n\*0x04 [n=0..5]  
**Reset:** 0x00  
**Property:** Enable-Protected

**Notes:**

1. SPI connections to the CCL work in master SPI mode only.
2. USART connections to the CCL work only when the USART is in one of the following modes:
  - Asynchronous USART
  - Synchronous USART master

	Bit	7	6	5	4	3	2	1	0
		INSEL1[3:0]				INSEL0[3:0]			
Access		R/W	R/W	R/W	R/W	R/W	R/W	R/W	R/W
Reset		0	0	0	0	0	0	0	0

**Bits 7:4 – INSEL1[3:0] LUT n Input 1 Source Selection**

These bits select the source for input 1 of LUT n.

Value	Name	Description
0x0	MASK	Masked input
0x1	FEEDBACK	Feedback input
0x2	LINK	Output from LUT[n+1] as input source
0x3	EVENTA	Event A as input source
0x4	EVENTB	Event B as input source
0x5	IN1	IN1 input source
0x6	AC1	AC1 OUT input source
0x7	ZCD1	ZCD1 OUT input source
0x8	USART1	USART1 TXD input source
0x9	SPI0	SPI0 MOSI input source
0xA	TCA0	TCA0 WO1 input source
0xB	TCA1	TCA1 WO1 input source
0xC	TCB1	TCB1 WO input source
0xD	TCD0	TCD0 WOB input source
Other	-	Reserved

**Bits 3:0 – INSEL0[3:0] LUT n Input 0 Source Selection**

These bits select the source for input 0 of LUT n.

Value	Name	Description
0x0	MASK	Masked input
0x1	FEEDBACK	Feedback input
0x2	LINK	Output from LUT[n+1] as input source
0x3	EVENTA	Event A as input source
0x4	EVENTB	Event B as input source
0x5	IN0	IN0 input source
0x6	AC0	AC0 OUT input source
0x7	ZCD0	ZCD0 OUT input source
0x8	USART0	USART0 TXD input source
0x9	SPI0	SPI0 MOSI input source
0xA	TCA0	TCA WO0 input source
0xB	TCA1	TCA1 WO0 input source

# AVR128DA28/32/48/64

## CCL – Configurable Custom Logic

---

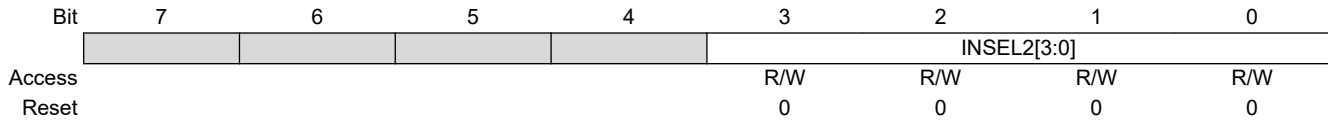
---

.....continued

Value	Name	Description
0xC	TCB0	TCB0 WO input source
0xD	TCD0	TCD0 WOA input source
Other	-	Reserved

### 29.5.10 LUT n Control C

**Name:** LUTnCTRLC  
**Offset:** 0x0A + n\*0x04 [n=0..5]  
**Reset:** 0x00  
**Property:** Enable-Protected



**Bits 3:0 – INSEL2[3:0]** LUT n Input 2 Source Selection  
 These bits select the source for input 2 of LUT n.

Value	Name	Description
0x0	MASK	Masked input
0x1	FEEDBACK	Feedback input
0x2	LINK	Output from LUT[n+1] as input source
0x3	EVENTA	Event A as input source
0x4	EVENTB	Event B as input source
0x5	IN2	IN2 input source
0x6	AC2	AC2 OUT input source
0x7	ZCD2	ZCD2 OUT input source
0x8	USART2	USART2 TXD input source
0x9	SPI0	SPI0 SCK input source
0xA	TCA0	TCA0 WO2 input source
0xB	TCA1	TCA1 WO2 input source
0xC	TCB2	TCB2 WO input source
0xD	TCD0	TCD0 WOC input source
Other	-	Reserved



**29.5.11 TRUTHn**

**Name:** TRUTHn  
**Offset:** 0x0B + n\*0x04 [n=0..5]  
**Reset:** 0x00  
**Property:** Enable-Protected

	7	6	5	4	3	2	1	0
	TRUTH[7:0]							
Access	R/W	R/W	R/W	R/W	R/W	R/W	R/W	R/W
Reset	0	0	0	0	0	0	0	0

**Bits 7:0 – TRUTH[7:0] Truth Table**

These bits define the value of truth logic as a function of inputs LUTn-TRUTHSEL[2:0]. See also section *Truth Table Logic*.

## 30. AC - Analog Comparator

### 30.1 Features

- Selectable Response Time
- Selectable Hysteresis
- Analog Comparator Output Available on Pin
- Comparator Output Inversion Available
- Flexible Input Selection:
  - 4 Positive pins
  - 3 Negative pins
  - Internal reference voltage generator (DACREF)
- Interrupt Generation on:
  - Rising edge
  - Falling edge
  - Both edges
- Window Function Interrupt Generation on:
  - Signal above window
  - Signal inside window
  - Signal below window
  - Signal outside window
- Event Generation:
  - Comparator output
  - Window function

### 30.2 Overview

The analog comparator (AC) compares the voltage levels on two inputs and gives a digital output based on this comparison. The AC can be configured to generate interrupt requests and/or events based on several different combinations of input change.

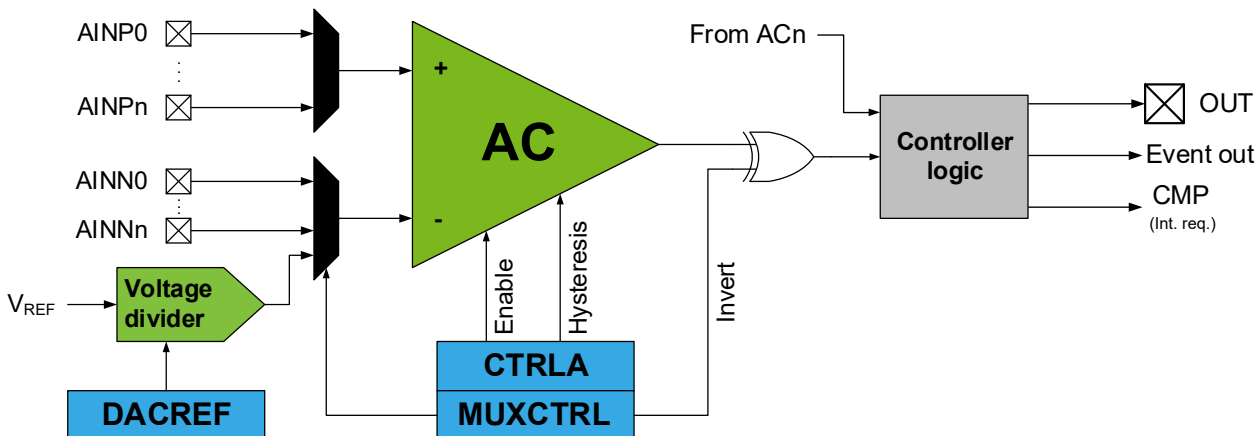
The input selection includes analog port pins and internally generated inputs. The AC digital output goes through controller logic, enabling customization of the signal for use internally with the Event System or externally on the pin.

The dynamic behavior of the AC can be adjusted by a hysteresis feature. The hysteresis can be customized to optimize the operation for each application.

The individual comparators can be used independently (Normal mode) or paired to form a window comparison (Window mode).

30.2.1 Block Diagram

Figure 30-1. Analog Comparator



30.2.2 Signal Description

Signal	Description	Type
AINNn	Negative input n	Analog
AINPn	Positive input n	Analog
OUT	Comparator output of AC	Digital

30.3 Functional Description

30.3.1 Initialization

For basic operation, follow these steps:

1. Configure the desired input pins in the port peripheral as analog inputs.
2. Select the positive and negative input sources by writing to the Positive and Negative Input MUX Selection (MUXPOS and MUXNEG) bit fields in the MUX Control (ACn.MUXCTRL) register.
3. Optional: Enable the output to pin by writing a '1' to the Output Pad Enable (OUTEN) bit in the Control A (ACn.CTRLA) register.
4. Enable the AC by writing a '1' to the ENABLE bit in ACn.CTRLA.

During the start-up time after enabling the AC, the INITVAL bit in the CTRLB register can be used to set the AC output before the AC is ready. If  $V_{REF}$  is used as a reference source, the respective start-up time of the reference source must be added. For details about the start-up time of the AC and VREF peripherals, refer to the *Electrical Characteristics* section.

To avoid the pin being tri-stated when the AC is disabled, the OUT pin must be configured as output.

30.3.2 Operation

30.3.2.1 Input Hysteresis

Applying an input hysteresis helps to prevent constant toggling of the output when the noise-afflicted input signals are close to each other.

The input hysteresis can either be disabled or have one of three levels. The hysteresis is configured by writing to the Hysteresis Mode Select (HYSMODE) bit field in the Control A (ACn.CTRLA) register. For details about typical values of hysteresis levels, refer to the *Electrical Characteristics* section.

### 30.3.2.2 Input and Reference Selection

The input selection to the AC<sub>n</sub> is controlled by the Positive and Negative Multiplexers (MUXPOS and MUXNEG) bit fields in the MUX Control (AC<sub>n</sub>.MUXCTRL) register. For positive input of AC<sub>n</sub>, an analog pin can be selected, while for negative input, the selection can be made between analog pins and internal DAC reference voltage (DACREF). For details about the possible selections, refer to the MUX Control (AC<sub>n</sub>.MUXCTRL) register description.

The generated voltage depends on the DACREF register value and the reference voltage selected in the VREF module, and is calculated as:

$$V_{\text{DACREF}} = \frac{\text{DACREF}}{256} \times V_{\text{REF}}$$

The internal reference voltages ( $V_{\text{REF}}$ ), except for  $V_{\text{REFA}}$  and  $V_{\text{DD}}$ , are generated from an internal band gap reference.

After switching inputs to I/O pins or setting a new voltage reference, the AC<sub>n</sub> requires time to settle. Refer to the *Electrical Characteristics* section for more details.

### 30.3.2.3 Normal Mode

The AC has one positive input and one negative input. The output of the comparator is '1' when the difference between the positive and the negative input voltage is positive, and '0' otherwise. This output is available on the output pin (OUT) through a logic XOR gate. This allows the inversion of the OUT pin when the INVERT bit in the MUX Control (AC<sub>n</sub>.MUXCTRL) register is '1'.

To avoid random output and set a specific level on the OUT pin during the AC<sub>n</sub> initialization, the INITVAL bit in the same register is used.

### 30.3.2.4 Power Modes

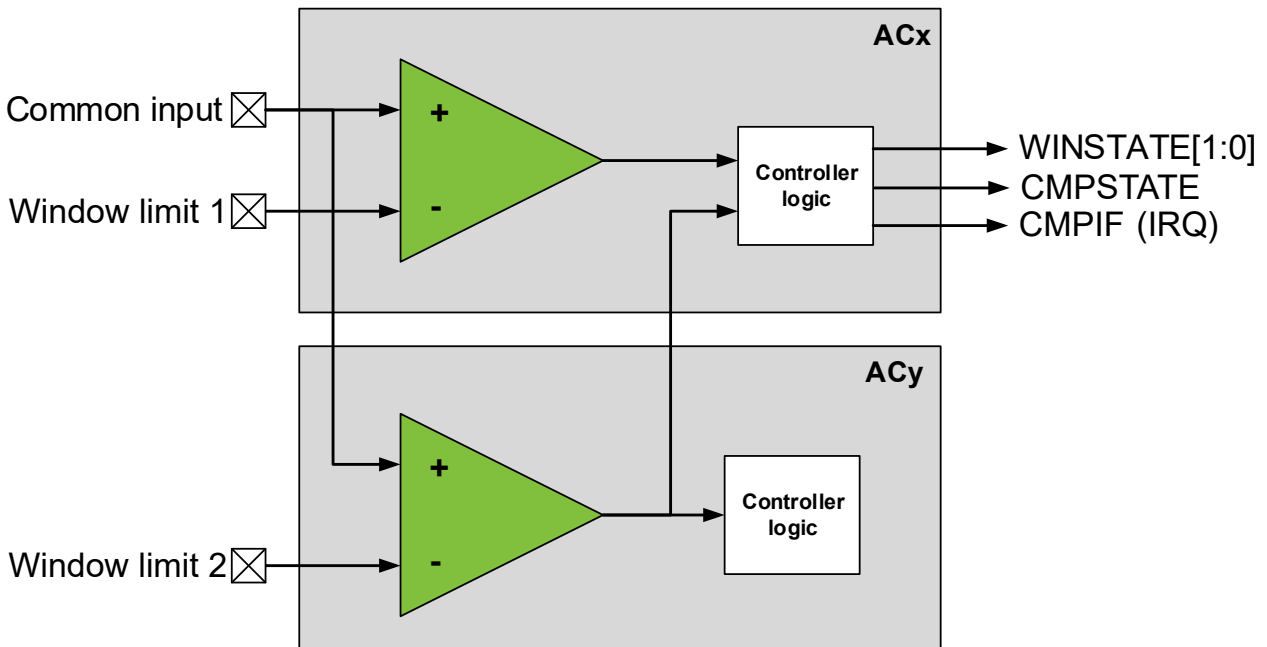
For power sensitive applications, the AC provides multiple power modes with balance power consumption and response time. A mode is selected by writing to the Power Profile (POWER) bit field in the Control A (AC<sub>n</sub>.CTRLA) register.

### 30.3.2.5 Window Mode

Each AC (i.e., AC<sub>x</sub>) can be configured to work together with another comparator (i.e., AC<sub>y</sub>) in Window mode. In this mode, a voltage range (the window) is defined, and the selected comparator indicates whether an input signal is within this range or not.

The WINSEL bit field in the Control B (AC<sub>n</sub>.CTRLB) register selects which AC<sub>y</sub> instance is connected to the current comparator (AC<sub>x</sub>) to create the window comparator. The user is responsible for configuring the MUXPOS and MUXNEG bit fields in the MUX Control (AC<sub>n</sub>.MUXCTRL) register for AC<sub>x</sub> and AC<sub>y</sub>, so they match the setup in the figure below. Note that the MUXPOS bit field in the AC<sub>n</sub>.MUXCTRL register of both ACs must be configured to the same pin.

Figure 30-2. Analog Comparators in Window Mode



The status of the input signal is reported by the Window State (WINSTATE) flags in the Status (ACn.STATUS) register. The status can be:

- Above window - the input signal is above the upper limit.
- Inside window - the input signal is between the lower and upper limits.
- Below window - the input signal is below the lower limit.

Writing to the INTMODE bit field in the Interrupt Control (INTCTRL) register selects one of these window modes for triggering an event or requesting an interrupt:

- Above window - the interrupt/event is issued when the input signal is above the upper limit.
- Inside window - the interrupt/event is issued when the input signal is between the lower and upper limits.
- Below window - the interrupt/event is issued when the input signal is below the lower limit.
- Outside window - the interrupt/event is issued when the input signal is not between the lower and upper limits.

The CMPSTATE bit is '1' when the Window state matches the selected Interrupt Mode (INTMODE) bit field and '0' otherwise.

The window interrupt is enabled by writing a '1' to the Analog Comparator Interrupt Enable (CMP) bit in the Interrupt Control (ACn.INTCTRL) register.

### 30.3.3 Events

The AC can generate the following events:

Table 30-1. Event Generators in AC

Generator Name		Description	Event Type	Generating Clock Domain	Length of Event
Module	Event				
ACn	OUT	Comparator output level	Level	Asynchronous	Given by AC output level

The AC has no event users.

Refer to the *Event System (EVSYS)* section for more details regarding event types and Event System configuration.

### 30.3.4 Interrupts

**Table 30-2. Available Interrupt Vectors and Sources**

Name	Vector Description	Conditions
CMP	Analog comparator interrupt	AC output is toggling as configured by INTMODE in ACn.INTCTRL

When an interrupt condition occurs, the corresponding interrupt flag is set in the Status (ACn.STATUS) register.

An interrupt source is enabled or disabled by writing to the corresponding bit in the peripheral's Interrupt Control (ACn.INTCTRL) register.

The AC can generate a comparator interrupt, CMP, and can request this interrupt on either rising, falling, or both edges of the toggling comparator output. This is configured by writing to the Interrupt Mode (INTMODE) bit field in the Interrupt Control (ACn.INTCTRL) register. The interrupt is enabled by writing a '1' to the Analog Comparator Interrupt Enable (CMP) bit in the Interrupt Control (ACn.INTCTRL) register. The interrupt request remains active until the interrupt flag is cleared. Refer to the Status (ACn.STATUS) register description for details on how to clear the interrupt flags.

### 30.3.5 Sleep Mode Operation

In Idle sleep mode the AC will continue to operate as normal.

In Standby sleep mode the AC is disabled by default. If the Run in Standby Mode (RUNSTDBY) bit in the Control A (ACn.CTRLA) register is written to '1', the AC will continue to operate as normal with an event, interrupt and AC output on the pin even if the CLK\_PER is not running in Standby sleep mode.

In Power-Down sleep mode the AC and the output to the pad are disabled.

### 30.4 Register Summary

Offset	Name	Bit Pos.	7	6	5	4	3	2	1	0
0x00	<a href="#">CTRLA</a>	7:0	RUNSTDBY	OUTEN		POWER[1:0]		HYSMODE[1:0]		ENABLE
0x01	<a href="#">CTRLB</a>	7:0							WINSEL[1:0]	
0x02	<a href="#">MUXCTRL</a>	7:0	INVERT	INITVAL		MUXPOS[2:0]		MUXNEG[2:0]		
0x03	Reserved									
0x04										
0x05	<a href="#">DACREF</a>	7:0	DACREF[7:0]							
0x06	<a href="#">INTCTRL</a>	7:0			INTMODE[1:0]					CMP
0x07	<a href="#">STATUS</a>	7:0	WINSTATE[1:0]			CMPSTATE				CMPIF

### 30.5 Register Description

## 30.5.1 Control A

**Name:** CTRLA  
**Offset:** 0x00  
**Reset:** 0x00  
**Property:** -

Bit	7	6	5	4	3	2	1	0
	RUNSTDBY	OUTEN		POWER[1:0]		HYSMODE[1:0]		ENABLE
Access	R/W	R/W		R/W	R/W	R/W	R/W	R/W
Reset	0	0		0	0	0	0	0

**Bit 7 – RUNSTDBY** Run in Standby Mode

Writing this bit to '1' allows the AC to continue operation in Standby sleep mode. Since the clock is stopped, interrupts and status flags are not updated.

Value	Description
0	In Standby sleep mode, the peripheral is halted
1	In Standby sleep mode, the peripheral continues operation

**Bit 6 – OUTEN** Output Pad Enable

Writing this bit to '1' makes the OUT signal available on the pin.

**Bits 4:3 – POWER[1:0]** Power Profile

This setting controls the current through the comparator, which allows the AC to trade power consumption for the response time. Refer to the *Electrical Characteristics* section for power consumption and response time.

Value	Name	Description
0x0	PROFILE0	Power profile 0. Shortest response time and highest consumption.
0x1	PROFILE1	Power profile 1
0x2	PROFILE2	Power profile 2
0x3	-	Reserved

**Bits 2:1 – HYSMODE[1:0]** Hysteresis Mode Select

Writing to this bit field selects the Hysteresis mode for the AC input. For details about typical values of hysteresis levels, refer to the *Electrical Characteristics* section.

Value	Name	Description
0x0	NONE	No hysteresis
0x1	SMALL	Small hysteresis
0x2	MEDIUM	Medium hysteresis
0x3	LARGE	Large hysteresis

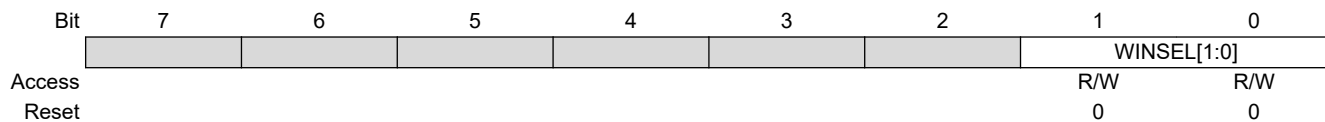
**Bit 0 – ENABLE** Enable AC

Writing this bit to '1' enables the AC.



### 30.5.2 Control B

**Name:** CTRLB  
**Offset:** 0x01  
**Reset:** 0x00  
**Property:** -



#### Bits 1:0 – WINSEL[1:0] Window Selection Mode

This bit field selects the AC connected to the current comparator in Window mode.

Value	Name	Description
0x0	DISABLED	Window function disabled
0x1	UPSEL1	Windows enabled, with ACn+1 connected
0x2	UPSEL2	Windows enabled, with ACn+2 connected
0x3	-	Reserved

## 30.5.3 MUX Control

**Name:** MUXCTRL  
**Offset:** 0x02  
**Reset:** 0x00  
**Property:** -

Bit	7	6	5	4	3	2	1	0
	INVERT	INITVAL	MUXPOS[2:0]			MUXNEG[2:0]		
Access	R/W	R/W	R/W	R/W	R/W	R/W	R/W	R/W
Reset	0	0	0	0	0	0	0	0

**Bit 7 – INVERT** Invert AC Output

Writing this bit to '1' enables inversion of the output of the AC. This inversion has to be taken into account when using the AC output signal as an input signal to other peripherals or parts of the system.

**Bit 6 – INITVAL** AC Output Initial Value

To avoid that the AC output toggles before the comparator is ready, the INITVAL can be used to set the initial state of the comparator output.

Value	Name	Description
0x0	LOW	Output initialized to '0'
0x1	HIGH	Output initialized to '1'

**Bits 5:3 – MUXPOS[2:0]** Positive Input MUX Selection

Writing to this bit field selects the input signal to the positive input of the AC.

Value	Name	Description
0x0	AINP0	Positive Pin 0
0x1	AINP1	Positive Pin 1
0x2	AINP2	Positive Pin 2
0x3	AINP3	Positive Pin 3
Other	-	Reserved

**Bits 2:0 – MUXNEG[2:0]** Negative Input MUX Selection

Writing to this bit field selects the input signal to the negative input of the AC.

Value	Name	Description
0x0	AINN0	Negative Pin 0
0x1	AINN1	Negative Pin 1
0x2	AINN2	Negative Pin 2
0x3	DACREF	DAC Reference
Other	-	Reserved

### 30.5.4 DAC Voltage Reference

**Name:** DACREF  
**Offset:** 0x05  
**Reset:** 0xFF  
**Property:** R/W

Bit	7	6	5	4	3	2	1	0
	DACREF[7:0]							
Access	R/W	R/W	R/W	R/W	R/W	R/W	R/W	R/W
Reset	1	1	1	1	1	1	1	1

**Bits 7:0 – DACREF[7:0]** DACREF Data Value

This bit field defines the output voltage from the internal voltage divider. The DAC voltage reference depends on the DACREF value and the reference voltage selected in the VREF module, and is calculated as:

$$V_{\text{DACREF}} = \frac{\text{DACREF}[7:0]}{256} \times V_{\text{REF}}$$

## 30.5.5 Interrupt Control

**Name:** INTCTRL  
**Offset:** 0x06  
**Reset:** 0x00  
**Property:** -

Bit	7	6	5	4	3	2	1	0
			INTMODE[1:0]					CMP
Access			R/W	R/W				R/W
Reset			0	0				0

**Bits 5:4 – INTMODE[1:0]** Interrupt Mode

Writing to this bit field selects which edge(s) of the AC output or when entering a window state triggers an interrupt request.

**Table 30-3. Interrupt Generation in Window Mode**

Value	Name	Description
0x0	ABOVE	Enables Window mode above interrupt
0x1	INSIDE	Enables Window mode inside interrupt
0x2	BELOW	Enables Window mode below interrupt
0x3	OUTSIDE	Enables Window mode outside interrupt

**Table 30-4. Interrupt Generation with Single Comparator**

Value	Name	Description
0x0	BOTHEDGE	Positive and negative inputs crosses
0x1	-	Reserved
0x2	NEGEDGE	Positive input goes above negative input
0x3	POSEDGE	Positive input goes below negative input

**Bit 0 – CMP** AC Interrupt Enable

This bit enables the AC interrupt. The enabled interrupt will be triggered when the CMPIF bit in the ACn.STATUS register is set.

**30.5.6 Status**

**Name:** STATUS  
**Offset:** 0x07  
**Reset:** 0x00  
**Property:** -

Bit	7	6	5	4	3	2	1	0
	WINSTATE[1:0]			CMPSTATE				CMPIF
Access	R	R		R				R/W
Reset	0	0		0				0

**Bits 7:6 – WINSTATE[1:0] Window State**

When the window function is enabled, these flags indicate the current status of the input signal with respect to the window.

Not valid when the Window mode is disabled.

**Table 30-5. Window State Settings**

Value	Name	Description
0x0	ABOVE	Above window
0x1	INSIDE	Inside window
0x2	BELOW	Below window
Other	-	Reserved

**Bit 4 – CMPSTATE AC State**

If this bit is '1', the OUT signal is high. If this bit is '0', the OUT signal is low. In Window mode, if this bit is '1', the Window state matches the selected Interrupt mode (INTMODE) bit field. If INTMODE is 'OUTSIDE', both 'ABOVE' and 'BELOW' are valid matches. It will have a synchronizer delay to get updated in the I/O register (three cycles).

**Bit 0 – CMPIF AC Interrupt Flag**

This bit is '1' when the OUT signal matches the Interrupt Mode (INTMODE) bit field as defined in the ACn.INTCTRL register. Writing a '1' to this flag bit location will clear the flag.

## 31. ADC - Analog-to-Digital Converter

### 31.1 Features

- 12-Bit Resolution
- Up to 130 ksps at 12-Bit Resolution
- Differential and Single-Ended Conversion
- Up to 22 Inputs
- Rail-to-Rail Input Voltage Range
- Free-Running and Single Conversion
- Accumulation of Up to 128 Samples per Conversion
- Multiple Voltage Reference Options
- Temperature Sensor Input Channel
- Programmable Input Sampling Duration
- Configurable Threshold and Window Comparator
- Event Triggered Conversion
- Interrupt and Event on Conversion Complete

### 31.2 Overview

The Analog-to-Digital Converter (ADC) is a 12-bit Successive Approximation Register (SAR) ADC, with a sampling rate up to 130 ksps at 12-bit resolution. The ADC is connected to an analog input multiplexer for selection between multiple single-ended or differential inputs. In single-ended conversions, the ADC measures the voltage between the selected input and 0V (GND). In differential conversions, the ADC measures the voltage between two selected input channels. The selected ADC input channels can either be internal (e.g., a voltage reference) or external analog input pins.

An ADC conversion can be started by software, or by using the Event System (EVSYS) to route an event from other peripherals. This makes it possible to do a periodic sampling of input signals, trigger an ADC conversion on a special condition or trigger an ADC conversion in Standby sleep mode.

A digital window compare feature is available for monitoring the input signal and can be configured only to trigger an interrupt if the sample is below or above a user-defined threshold, or inside or outside a user-defined window, with minimum software intervention required.

The ADC input signal is fed through a sample-and-hold circuit which ensures that the input voltage to the ADC is held at a constant level during sampling.

The ADC supports sampling in bursts where a configurable number of conversions are accumulated into a single ADC result (Sample Accumulation). Furthermore, a sample delay can be configured to tune the ADC burst sampling frequency away from any harmonic noise aliased from the sampled signal.

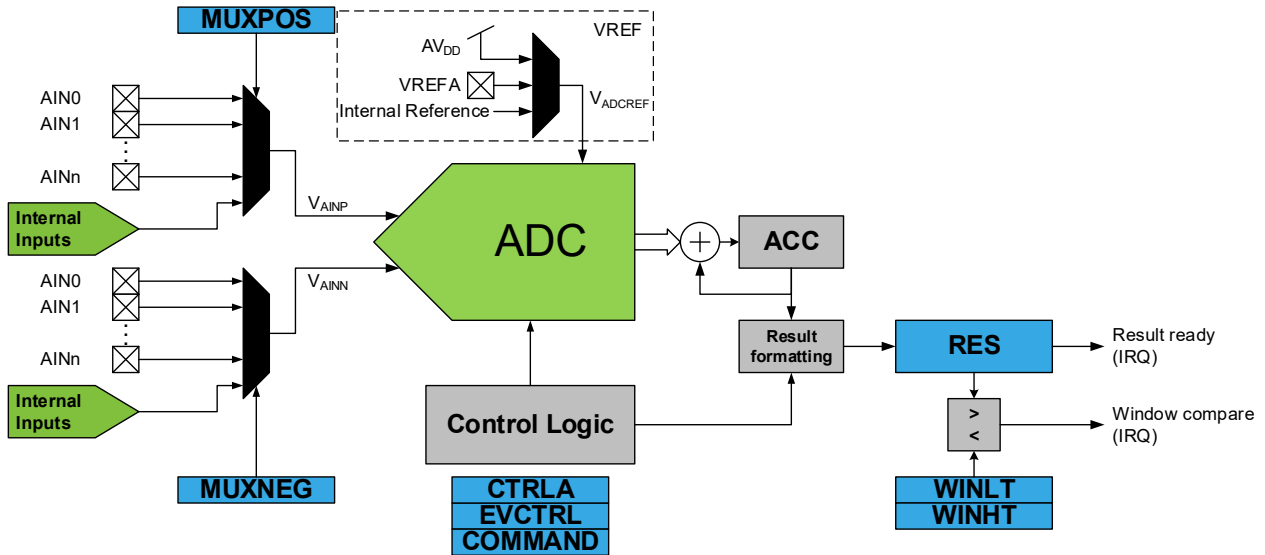
The ADC voltage reference is configured in the Voltage Reference (VREF) peripheral and can use one of the following sources as voltage reference:

- Multiple Internally Generated Voltages
- $AV_{DD}$  Supply Voltage
- External VREF Pin (VREFA)

This device has one instance of the ADC peripheral: ADC0.

### 31.2.1 Block Diagram

Figure 31-1. Block Diagram



### 31.2.2 Signal Description

Pin Name	Type	Description
AIN[n:0]	Analog input	Analog input to be converted
VREFA	Analog input	External voltage reference pin

## 31.3 Functional Description

### 31.3.1 Definitions

- Conversion: The operation in which analog values on the selected ADC inputs are transformed into a digital representation.
- Sample: The output of a single ADC conversion.
- Result: The value placed in the Result (ADCn.RES) register. Depending on the ADC configuration, this value is a single sample or the sum of multiple accumulated samples.

### 31.3.2 Initialization

The following steps are recommended to initialize ADC operation:

1. Configure the ADC voltage reference in the Voltage Reference (VREF) peripheral.
2. Optional: Select between Single-Ended or Differential mode by writing to the Conversion Mode (CONVMODE) bit in the Control A (ADCn.CTRLA) register.
3. Configure the resolution by writing to the Resolution Selection (RESSEL) bit field in the ADCn.CTRLA register.
4. Optional: Configure to left adjust by writing a '1' to the Left Adjust Result (LEFTADJ) bit in the ADCn.CTRLA register.
5. Optional: Select the Free-Running mode by writing a '1' to the Free-Running (FREERUN) bit in the ADCn.CTRLA register.
6. Optional: Configure the number of samples to be accumulated per conversion by writing to the Sample Accumulation Number Select (SAMPNUM) bit field in the Control B (ADCn.CTRLB) register.
7. Configure the ADC clock (CLK\_ADC) by writing to the Prescaler (PRESC) bit field in the Control C (ADCn.CTRLC) register.

8. Select the positive ADC input by writing to the MUXPOS bit field in the ADCn.MUXPOS register.
9. Optional: Select the negative ADC input by writing to the MUXNEG bit field in the ADCn.MUXNEG register.
10. Optional: Enable Start Event input by writing a '1' to the Start Event Input (STARTEI) bit in the Event Control (ADCn.EVCTRL) register, and configure the Event System accordingly.
11. Enable the ADC by writing a '1' to the ADC Enable (ENABLE) bit in the ADCn.CTRLA register.

Following these steps will initialize the ADC for basic measurements.

For details about the start-up time of the VREF peripheral, refer to the *Electrical Characteristics* section.

The ADC does not consume power when the ENABLE bit is '0'. The ADC generates a 10- or 12-bit result which can be read from the Result (ADCn.RES) register.

**Notes:** Changing the following registers during a conversion will give unpredictable results:

- In ADCn.CTRLA:
  - Conversion Mode (CONVMODE) bit
  - Left Adjust Result (LEFTADJ) bit
  - Resolution Selection (RESSEL) bit field
- In ADCn.CTRLB:
  - Sample Accumulation Number Select (SAMPNUM) bit field
- In ADCn.CTRLA:
  - Prescaler (PRESC) bit field

### 31.3.3 Operation

#### 31.3.3.1 Operation Modes

The ADC supports differential and single-ended conversions. This is configured in the CONVMODE bit in the ADCn.CTRLA register.

The operation modes can be split into two groups:

- Single conversion of one sample per trigger
- Accumulated conversion of n conversions per trigger, the result is accumulated

The accumulated conversion utilizes 12-bit conversions and can be configured with or without truncation of the accumulated result. The accumulator is always reset to zero when a new accumulated conversion is started.

#### 31.3.3.2 Starting a Conversion

Once the initialization is finished, a conversion is started by writing a '1' to the ADC Start Conversion (STCONV) bit in the Command (ADCn.COMMAND) register. This bit is '1' as long as the conversion is in progress. The STCONV bit will be set during a conversion and cleared once the conversion is complete.

If a different input channel is selected while a conversion is in progress, the ADC will finish the current conversion before changing the channel.

Depending on the accumulator setting, the conversion result is a single sample, or an accumulation of samples. Once the triggered operation is finished, the Result Ready (RESRDY) flag in the Interrupt Flags (ADCn.INTFLAGS) register is set. The corresponding interrupt vector is executed if the Result Ready Interrupt Enable (RESRDY) bit in the Interrupt Control (ADCn.INTCTRL) register is '1' and the Global Interrupt Enable bit is '1'.

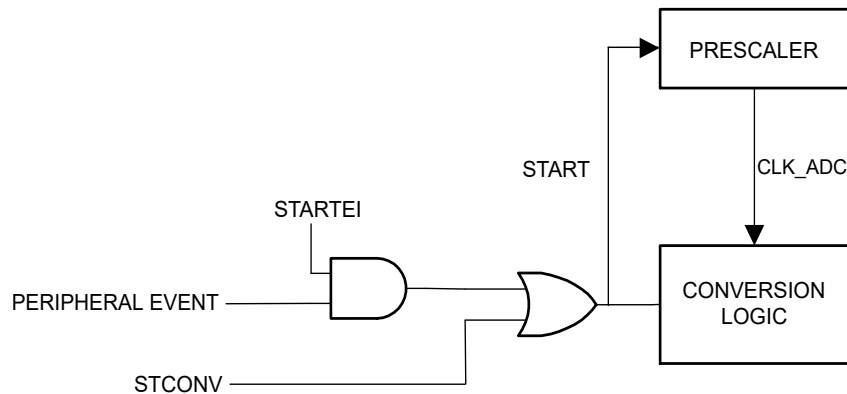
The RESRDY interrupt flag in the ADCn.INTFLAGS register will be set even if the specific interrupt is disabled, allowing software to check for any finished conversion by polling the flag. A conversion can thus be triggered without causing an interrupt upon completion.

Alternatively, a conversion can be triggered by an event. This is enabled by writing a '1' to the Start Event Input (STARTEI) bit in the Event Control (ADCn.EVCTRL) register. Any incoming event routed to the ADC through the Event System (EVSYS) will trigger an ADC conversion. This provides a method to start conversions with predictable intervals or at specific conditions.

The ADC will trigger a conversion on the rising edge of an event signal. When an event occurs, the STCONV bit in the ADCn.COMMAND register is set and it will be cleared when the conversion is complete. Refer to [Figure 31-2](#).



**Figure 31-2. ADC Event Trigger Logic**

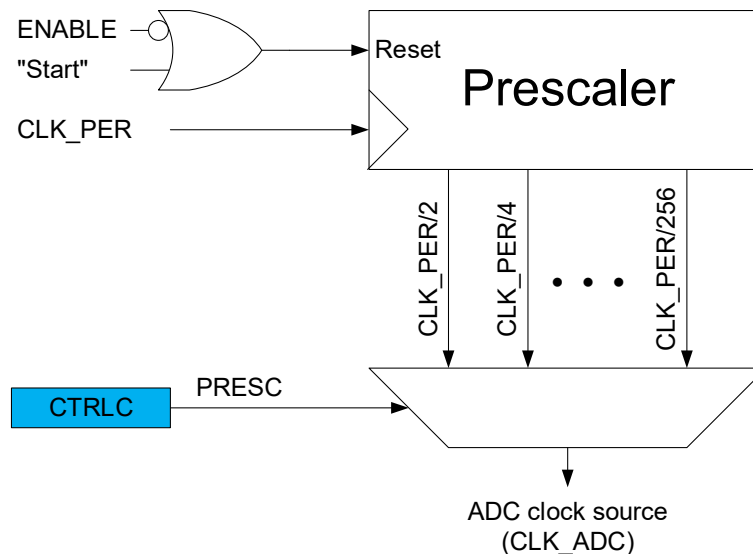


In Free-Running mode, the first conversion is started by writing a '1' to the STCONV bit in the ADCn.COMMAND register. A new conversion cycle is started immediately after the previous conversion cycle has completed. A completed conversion will set the RESRDY flag in the ADCn.INTFLAGS register.

### 31.3.3.3 Clock Generation

The ADC peripheral contains a prescaler which generates the ADC clock (CLK\_ADC) from the peripheral clock (CLK\_PER). The minimum ADC\_CLK frequency is 150 kHz. The prescaling is selected by writing to the Prescaler (PRESC) bit field in the Control C (ADCn.CTRLC) register. The prescaler begins counting from the moment the ADC conversion starts and is reset for every new conversion. Refer to [Figure 31-3](#).

**Figure 31-3. ADC Prescaler**



When initiating a conversion by writing a '1' to the Start Conversion (STCONV) bit in the ADCn.COMMAND register or from event, the conversion starts after one CLK\_PER cycle. The prescaler is kept in Reset, as long as there is no ongoing conversion. This assures a fixed delay from the trigger to the actual start of a conversion of maximum 2 CLK\_PER cycles.

### 31.3.3.4 Conversion Timing

A normal conversion takes place in the following order:

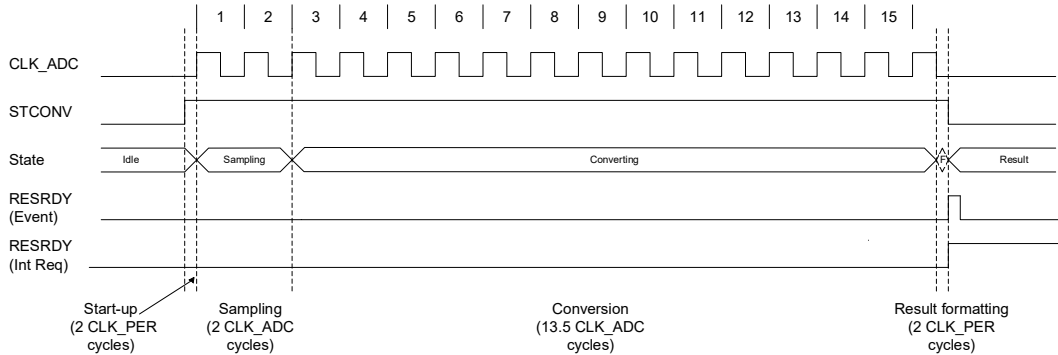
1. Write a '1' to the STCONV bit in the Command (ADCn.COMMAND) register.
2. Start-up for maximum 2 CLK\_PER cycles.
3. Sample-and-hold for 2 CLK\_ADC cycles.
4. Conversion for 13.5 CLK\_ADC cycles.
5. Result formatting for 2 CLK\_PER cycles.

When a conversion is complete, the result is available in the Result (ADCn.RES) register, and the Result Ready (RESRDY) interrupt flag is set in the Interrupt Flags (ADCn.INTFLAGS) register.

### 31.3.3.4.1 Single Conversion

The figure below shows the timing diagram for a single 12-bit ADC conversion.

**Figure 31-4. Timing Diagram - Single Conversion**



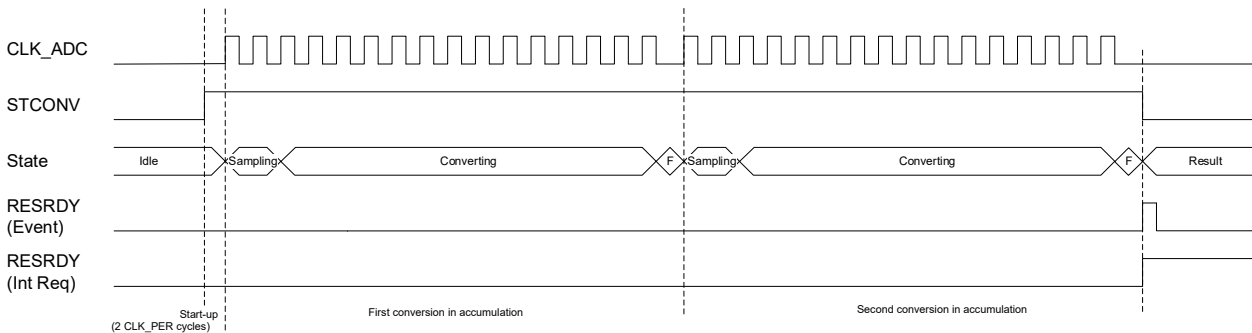
For a single conversion, the total conversion time is calculated by:

$$\text{Total Conversion Time (12-bit)} = \frac{13.5 + 2}{f_{\text{CLK\_ADC}}} + \frac{4}{f_{\text{CLK\_PER}}}$$

### 31.3.3.4.2 Accumulated Conversion

The figure below shows the timing diagram for the ADC when accumulating two samples in Accumulation mode.

**Figure 31-5. Timing Diagram - Accumulated Conversion**



The number of samples to accumulate is configured with the Sample Number (SAMPNUM) bit field in the Control B (ADCn.CTRLB) register. The STCONV bit is set for the entire conversion. The total conversion time for n samples is given by:

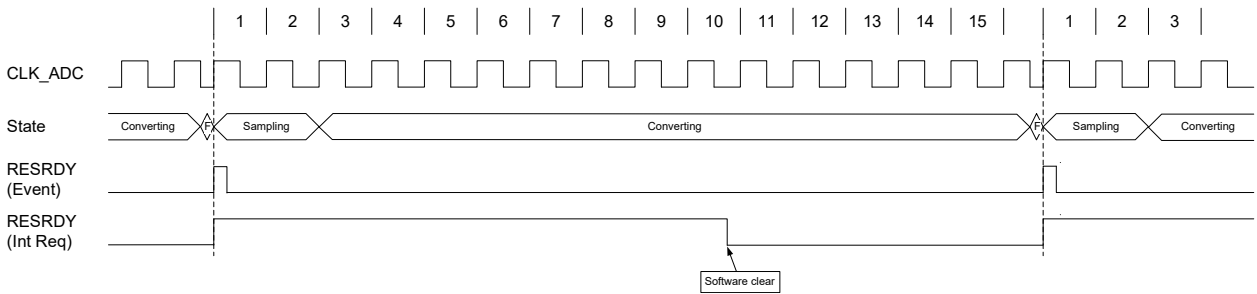
$$\text{Total Conversion Time (12-bit)} = \frac{2}{f_{\text{CLK\_PER}}} + n \left( \frac{13.5 + 2}{f_{\text{CLK\_ADC}}} + \frac{2}{f_{\text{CLK\_PER}}} \right)$$

### 31.3.3.4.3 Free-Running Conversion

In Free-Running mode, a new conversion is started as soon as the previous conversion has completed. This is signaled by the RESRDY bit in the Interrupt Flags (ADCn.INTFLAGS) register.

The figure below shows the timing diagram for the ADC in Free-Running mode with single conversion.

**Figure 31-6. Timing Diagram - Free-Running Conversion**



The Result Ready event and the interrupt flag are set after each conversion. It is possible to combine accumulated conversion and Free-Running mode.

To safely change any of these settings when using Free-Running mode, disable Free-Running mode, and wait for the conversion to complete before doing any changes. Enable Free-Running mode again before starting the next conversion.

### 31.3.3.4.4 Adjusting Conversion Time

Both sampling time and sampling length can be adjusted using the Sampling Delay Selection (SAMPDLY) bit field in the Control D (ADCn.CTRLD) register and Sample Length (SAMPLLEN) bit field in the Sample Control (ADCn.SAMPCTRL) register. Both of these control the ADC sampling time and sampling length in a number of CLK\_ADC cycles. Increasing SAMPLEN allows sampling high-impedance sources without reducing CLK\_ADC frequency. Adjusting SAMPDLY is intended for tuning the sampling frequency away from harmonic noise in the analog signal. Total sampling time is given by:

$$\text{SampleTime} = \frac{(2 + \text{SAMPDLY} + \text{SAMPLLEN})}{f_{\text{CLK\_ADC}}}$$

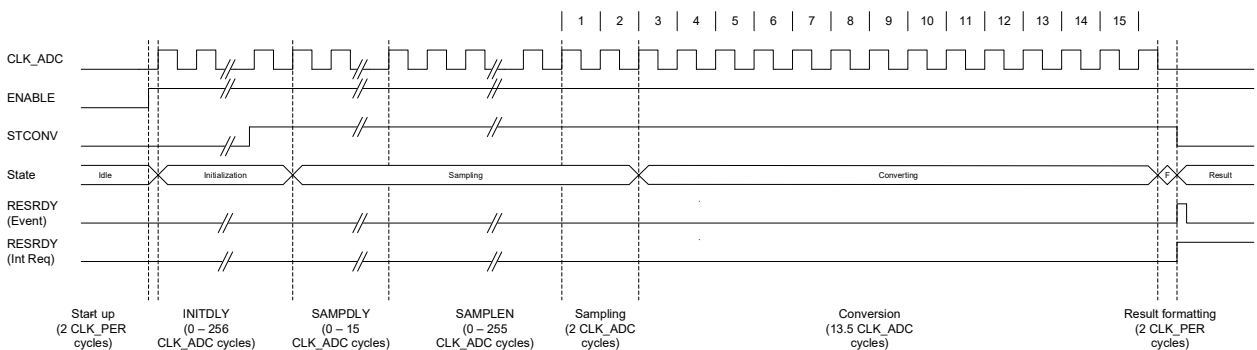
The equation above implies that the total conversion time for n samples is now:

$$\text{Total Conversion Time (12-bit)} = \frac{2}{f_{\text{CLK\_PER}}} + n \left( \frac{13.5 + 2 + \text{SAMPDLY} + \text{SAMPLLEN}}{f_{\text{CLK\_ADC}}} + \frac{2}{f_{\text{CLK\_PER}}} \right)$$

Some of the analog resources used by the ADC require time to initialize before a conversion can start. The Initialization Delay (INITDLY) bit field in the Control D (ADCn.CTRLD) register can be used to prevent starting a conversion prematurely by halting sampling for the configured delay duration.

The figure below shows the timing diagram for the ADC and the usage of the INITDLY, SAMPDLY and SAMPLEN bit fields:

**Figure 31-7. Timing Diagram - Conversion with Delays and Custom Sampling Length**



### 31.3.3.5 Conversion Result (Output Formats)

The result of an analog-to-digital conversion is written to the 16-bit Result (ADCn.RES) register and is given by the following equations:

$$\text{Single-ended 12-bit conversion: } RES = \frac{V_{\text{AINP}}}{V_{\text{ADCREf}}} \times 4096 \in [0, 4095]$$

Single-ended 10-bit conversion:  $RES = \frac{V_{AINP}}{V_{ADCREf}} \times 1024 \in [0, 1023]$

Differential 12-bit conversion:  $RES = \frac{V_{AINP} - V_{AINN}}{V_{ADCREf}} \times 2048 \in [-2048, 2047]$

Differential 10-bit conversion:  $RES = \frac{V_{AINP} - V_{AINN}}{V_{ADCREf}} \times 512 \in [-512, 511]$

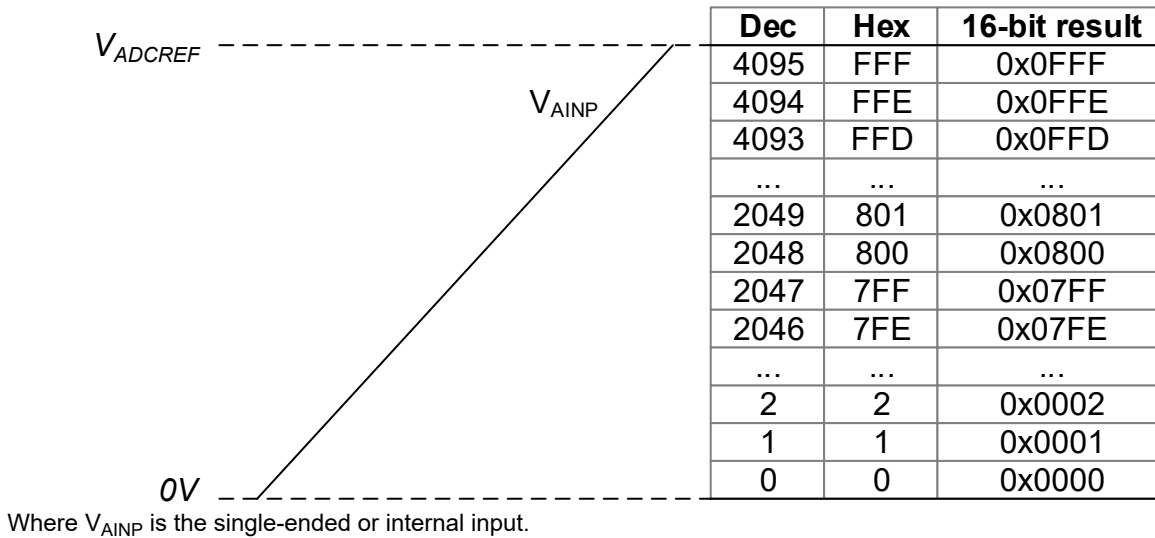
where  $V_{AINP}$  and  $V_{AINN}$  are the positive and negative ADC inputs and  $V_{ADCREf}$  is the selected ADC voltage reference.

The data format used for single-ended conversions is unsigned one's complement, while two's complement with sign extension is used for differential conversions. Consequently, for differential conversions the sign bit is padded to the higher bits in the Result register, if needed.

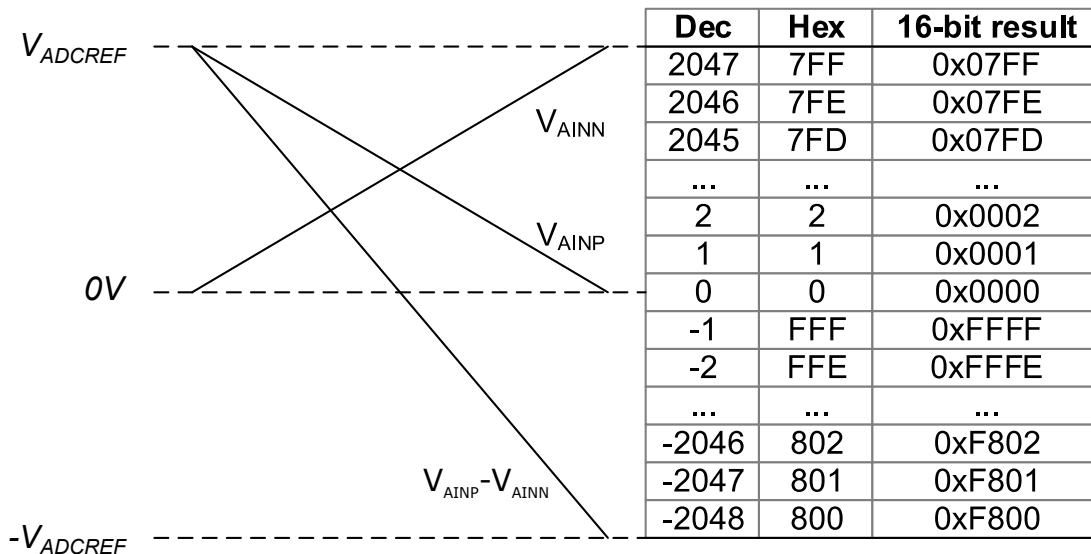
By default, conversion results are stored in the Result register as right-adjusted 16-bit values. The eight Least Significant bits (LSBs) are then located in the low byte of the Result register. By writing a '1' to the Left Adjust Result (LEFTADJ) bit in the Control A (ADCn.CTRLA) register, the values will be left-adjusted by placing the eight Most Significant bits (MSBs) in the high byte of the Result register.

The two figures below illustrate the relationship between the analog input and the corresponding ADC output.

**Figure 31-8. Unsigned Single-Ended, Input Range, and Result Representation**



**Figure 31-9. Signed Differential Input, Input Range, and Result Representation**



If a single-ended analog input is above the ADC voltage reference level, the 12-bit ADC result will be 0xFFFF (decimal 4095). Likewise, if the input is below 0V, the ADC result will be 0x000.

If the voltage difference between  $V_{AINP}$  and  $V_{AINN}$  for a 12-bit differential conversion is above the ADC voltage reference level, the ADC result will be 0x7FF (decimal 2047). If the voltage difference is larger than the voltage reference level in the negative direction, the ADC result will be 0x800 (decimal -2048).

### 31.3.3.6 Accumulation

By default, conversion results are stored in the Result register as right-adjusted 16-bit values. The eight Least Significant bits (LSBs) are then located in the low byte of the Result register. By writing a '1' to the Left Adjust Result (LEFTADJ) bit in the Control A (ADCn.CTRLA) register, the values will be left-adjusted by placing the eight Most Significant bits (MSBs) in the high byte of the Result register.

The result from multiple consecutive conversions can be accumulated. The number of samples to be accumulated is specified by the Sample Accumulation Number Select (SAMPNUM) bit field in the Control B (ADCn.CTRLB) register. When accumulating more than 16 samples, the result might be too large to match the 16-bit Result register size. To avoid overflow, the LSBs of the result are truncated to fit within the available register size.

The two following tables show how the Result (ADCn.RES) register value is stored for single-ended and differential conversions.

**Table 31-1. Result Format in Single-Ended Mode**

Accumulations	LEFTADJ	RES[15:8]										RES[7:0]							
		Bit 15	Bit 14	Bit 13	Bit 12	Bit 11	Bit 10	Bit 9	Bit 8	Bit 7	Bit 6	Bit 5	Bit 4	Bit 3	Bit 2	Bit 1	Bit 0		
1	0	0	0	0	0	Conversion [11:0]													
	1	Conversion [11:0]										0	0	0	0				
2	0	0	0	0	Accumulation [12:0]														
	1	Accumulation [12:0]												0	0	0			
4	0	0	0	Accumulation [13:0]															
	1	Accumulation [13:0]													0	0			
8	0	0	Accumulation [14:0]																
	1	Accumulation [14:0]														0			

# AVR128DA28/32/48/64

## ADC - Analog-to-Digital Converter

.....continued

Accumulations	LEFTADJ	RES[15:8]										RES[7:0]					
		Bit 15	Bit 14	Bit 13	Bit 12	Bit 11	Bit 10	Bit 9	Bit 8	Bit 7	Bit 6	Bit 5	Bit 4	Bit 3	Bit 2	Bit 1	Bit 0
16	0	Accumulation [15:0]															
	1																
32, 64, 128	0	Truncated Accumulation [15:0]															
	1																

**Table 31-2. Result Format in Differential Mode**

Accumulations	LEFTADJ	RES[15:8]										RES[7:0]					
		Bit 15	Bit 14	Bit 13	Bit 12	Bit 11	Bit 10	Bit 9	Bit 8	Bit 7	Bit 6	Bit 5	Bit 4	Bit 3	Bit 2	Bit 1	Bit 0
1	0	Sign extension					Signed conversion [11:0]										
	1	Signed conversion [11:0]												0	0	0	0
2	0	Sign extension					Signed accumulation [12:0]										
	1	Signed accumulation [12:0]												0	0	0	
4	0	Sign extension					Signed accumulation [13:0]										
	1	Signed accumulation [13:0]												0	0		
8	0	Sign extension					Signed accumulation [14:0]										
	1	Signed accumulation [14:0]												0			
16	0	Signed accumulation [15:0]															
	1	Signed accumulation [15:0]															
32, 64, 128	0	Signed truncated accumulation [15:0]															
	1	Signed truncated accumulation [15:0]															

### 31.3.3.7 Channel Selection

The input selection for the ADC is controlled by the MUXPOS and MUXNEG bit fields in the ADCn.MUXPOS and ADCn.MUXNEG registers, respectively. If the ADC is running single-ended conversions, only MUXPOS is used, while both are used in differential conversions.

The MUXPOS bit field of the ADCn.MUXPOS register and the MUXNEG bit field of the ADCn.MUXNEG register are buffered through a temporary register. This ensures that the input selection only comes into effect at a safe point during the conversion. The channel selections are continuously updated until a conversion is started.

Once the conversion starts, the channel selections are locked to ensure sufficient sampling time for the ADC. The continuous updating of input channel selection resumes in the last CLK\_ADC clock cycle before the conversion completes. The next conversion starts on the following rising CLK\_ADC clock edge after the STCONV bit is written to '1'.

### 31.3.3.8 Temperature Measurement

An on-chip temperature sensor is available. Follow the steps below to do a temperature measurement. The resulting value will be right-adjusted.

1. In the Voltage Reference (VREF) peripheral, select the internal 2.048V reference as the ADC reference voltage.
2. Select the temperature sensor as input in the ADCn.MUXPOS register.

3. Acquire the temperature sensor output voltage by running a 12-bit, right-adjusted, single-ended conversion.
4. Process the measurement result as described below.

The measured voltage has an almost linear relationship with the temperature. Due to process variations, the temperature sensor output voltage varies between individual devices at the same temperature. The individual compensation factors determined during production test are stored in the Signature Row. These compensations factors are generated for the internal 2.048V reference.

- SIGROW.TEMPSENSE0 contains the slope of the temperature sensor characteristics
- SIGROW.TEMPSENSE1 contains the offset of the temperature sensor characteristics

In order to achieve more accurate results, the result of the temperature sensor measurement must be processed in the application software using compensation values from device production or user calibration. The temperature (in Kelvin) is calculated by the following equation:

$$T = \frac{(\text{Offset} - \text{ADC Result}) \times \text{Slope}}{4096}$$

It is recommended to follow these steps in the application code when using the compensation values from the Signature Row:

```
uint16_t sigrow_offset = SIGROW.TEMPSENSE1; // Read unsigned value from signature row
uint16_t sigrow_slope = SIGROW.TEMPSENSE0; // Read unsigned value from signature row
uint16_t adc_reading = ADCn.RES;           // ADC conversion result

uint32_t temp = sigrow_offset - adc_reading;
temp *= sigrow_slope; // Result will overflow 16-bit variable
temp += 0x0800;       // Add 4096/2 to get correct rounding on division below
temp >>= 12;          // Round off to nearest degree in Kelvin, by dividing with 2^12 (4096)
uint16_t temperature_in_K = temp;
```

To increase the precision of the measurement to less than 1 Kelvin it is possible to adjust the last two steps to round off to a fraction of one degree. Add 4096/4 and right shift by 11 for a precision of ½ Kelvin, or add 4096/8 and right shift by 10 for a ¼ Kelvin precision.

If accumulation is used to reduce noise in the temperature measurement, the ADC result needs to be adjusted to a 12-bit value before the calculation is performed.

If another reference ( $V_{\text{ADCREf}}$ ) than 2.048V is required, the offset and slope values need to be adjusted according to the following equations:

$$\text{Slope} = \text{TEMPSENSE0} \times \frac{V_{\text{ADCREf}}}{2.048\text{V}}$$

$$\text{Offset} = \text{TEMPSENSE1} \times \frac{2.048\text{V}}{V_{\text{ADCREf}}}$$

### 31.3.3.9 Window Comparator

The ADC can raise the Window Comparator Interrupt (WCMP) flag in the Interrupt Flags (ADCn.INTFLAGS) register and request an interrupt (WCMP) when the output of a conversion or accumulation is above and/or below certain thresholds. The available modes are:

- The result is below a threshold
- The result is above a threshold
- The result is inside a window (above the lower threshold and below the upper threshold)
- The result is outside a window (either under the lower threshold or above the upper threshold)

The thresholds are defined by writing to the Window Comparator Low and High Threshold (ADCn.WINLT and ADCn.WINHT) registers. Writing to the Window Comparator Mode (WINCM) bit field in the Control E (ADCn.CTRLE) register selects the Window mode to use.

When accumulating multiple samples, the comparison between the result and the threshold will happen after the last sample was acquired. Consequently, the flag is raised only once, after taking the last sample of the accumulation.

Assuming the ADC is already configured to run, follow these steps to use the Window Comparator:

1. Set the required threshold(s) by writing to the Window Comparator Low and High Threshold (ADCn.WINLT and ADCn.WINHT) registers.
2. Optional: Enable the interrupt request by writing a '1' to the Window Comparator Interrupt Enable (WCMP) bit in the Interrupt Control (ADCn.INTCTRL) register.
3. Enable the Window Comparator and select a mode by writing a valid non-zero value to the Window Comparator Mode (WINCM) bit field in the Control E (ADCn.CTRLE) register.

When accumulating samples, the window comparator thresholds are applied to the accumulated value and not to each sample. Using left adjustment of the result will make the comparator values independent of number of samples.

### 31.3.4 I/O Lines and Connections

The analog input pins and the VREF pin (AINx and VREFA) are configured in the I/O Pin Controller (PORT).

To reduce power consumption, the digital input buffer has to be disabled on the pins used as inputs for ADC. This is configured by the I/O Pin Controller (PORT).

### 31.3.5 Events

The ADC can generate the following events:

**Table 31-3. Event Generators in ADC**

Generator Name		Description	Event Type	Generating Clock Domain	Length of Event
Peripheral	Event				
ADCn	RESRDY	Result ready	Pulse	CLK_PER	One clock period

The conditions for generating an event are identical to those that will raise the corresponding flag in the Interrupt Flags (ADCn.INTFLAGS) register.

The ADC has one event user for detecting and acting upon input events. The table below describes the event user and the associated functionality.

**Table 31-4. Event Users and Available Event Actions in ADC**

User Name		Description	Input Detection	Async/Sync
Peripheral	Input			
ADCn	START	ADC start conversion	Edge	Async

The ADC can be configured to start a conversion on the rising edge of an event signal by writing a '1' to the STARTEN bit field in the Event Control (ADCn.EVCTRL) register. Refer to the *Event System (EVSYS)* section for more details regarding event types and Event System configuration.

When an input event trigger occurs, the positive edge will be detected, the Start Conversion (STCONV) bit in the Command (ADCn.COMMAND) register will be set, and the conversion will start. When the conversion is completed, the Result Ready (RESRDY) flag in the Interrupt Flags (ADCn.INTFLAGS) register is set and the STCONV bit in ADCn.COMMAND is cleared.

### 31.3.6 Interrupts

**Table 31-5. Available Interrupt Vectors and Sources**

Name	Vector Description	Conditions
RESRDY	Result Ready interrupt	The conversion result is available in ADCn.RES.
WCMP	Window Comparator interrupt	As defined by WINCM in ADCn.CTRLE.

When an interrupt condition occurs, the corresponding interrupt flag is set in the Interrupt Flags (ADCn.INTFLAGS) register.



An interrupt source is enabled or disabled by writing to the corresponding enable bit in the Interrupt Control (ADCn.INTCTRL) register.

An interrupt request is generated when the corresponding interrupt source is enabled and the interrupt flag is set. The interrupt request remains active until the interrupt flag is cleared. Refer to the ADCn.INTFLAGS register for details on how to clear interrupt flags.

### **31.3.7 Debug Operation**

By default, halting the CPU in Debugging mode will halt the normal operation of the peripheral.

This peripheral can be forced to operate while the CPU is halted by writing a '1' to the Debug Run (DBGRUN) bit in the Debug Control (ADCn.DBGCTRL) register.

### **31.3.8 Sleep Mode Operation**

By default, the ADC is disabled in Standby sleep mode.

The ADC can stay fully operational in Standby sleep mode if the Run in Standby (RUNSTDBY) bit in the Control A (ADCn.CTRLA) register is written to '1'.

In this case, the ADC will stay active, any ongoing conversions will be completed, and interrupts will be executed as configured.

In Standby sleep mode, an ADC conversion can be triggered only via the Event System (EVSYS), or the ADC must be in Free-Running mode with the first conversion triggered by software before entering sleep. The peripheral clock is requested if needed and is turned off after the conversion is completed.

The reference source and supply infrastructure need time to stabilize when activated in Standby sleep mode. Configure a delay for the start of the first conversion by writing a non-zero value to the Initialization Delay (INITDLY) bit field in the Control D (ADCn.CTRLD) register.

In Power-Down sleep mode, no conversions are possible. Any ongoing conversions are halted and will be resumed when going out of sleep. At the end of the conversion, the Result Ready (RESRDY) flag will be set, but the content of the Result (ADCn.RES) registers will be invalid since the ADC was halted during a conversion. It is recommended to make sure conversions have completed before entering Power-Down sleep mode.

### **31.3.9 Synchronization**

Not applicable.

### **31.3.10 Configuration Change Protection**

Not applicable.

### 31.4 Register Summary

Offset	Name	Bit Pos.	7	6	5	4	3	2	1	0	
0x00	CTRLA	7:0	RUNSTDBY		CONVMODE	LEFTADJ	RESSEL[1:0]		FREERUN	ENABLE	
0x01	CTRLB	7:0					SAMPNUM[2:0]				
0x02	CTRLC	7:0					PRESC[3:0]				
0x03	CTRLD	7:0	INITDLY[2:0]				SAMPDLY[3:0]				
0x04	CTRLF	7:0					WINCM[2:0]				
0x05	SAMPCTRL	7:0	SAMPLEN[7:0]								
0x06	...										
0x07	Reserved										
0x08	MUXPOS	7:0		MUXPOS[6:0]							
0x09	MUXNEG	7:0		MUXNEG[6:0]							
0x0A	COMMAND	7:0							SPCONV	STCONV	
0x0B	EVCTRL	7:0								STARTEI	
0x0C	INTCTRL	7:0							WCMP	RESRDY	
0x0D	INTFLAGS	7:0							WCMP	RESRDY	
0x0E	DBGCTRL	7:0								DBGRUN	
0x0F	TEMP	7:0	TEMP[7:0]								
0x10	RES	7:0	RES[7:0]								
		15:8	RES[15:8]								
0x12	WINLT	7:0	WINLT[7:0]								
		15:8	WINLT[15:8]								
0x14	WINHT	7:0	WINHT[7:0]								
		15:8	WINHT[15:8]								

### 31.5 Register Description

### 31.5.1 Control A

**Name:** CTRLA  
**Offset:** 0x00  
**Reset:** 0x00  
**Property:** -

	7	6	5	4	3	2	1	0
	RUNSTDBY		CONVMODE	LEFTADJ	RESSEL[1:0]		FREERUN	ENABLE
Access	R/W		R/W	R/W	R/W	R/W	R/W	R/W
Reset	0		0	0	0	0	0	0

**Bit 7 – RUNSTDBY** Run in Standby  
 This bit determines whether the ADC still runs during Standby.

Value	Description
0	ADC will not run in Standby sleep mode. An ongoing conversion will finish before the ADC enters sleep mode
1	ADC will run in Standby sleep mode

**Bit 5 – CONVMODE** Conversion Mode  
 This bit defines if the ADC is working in Single-Ended or Differential mode.

Value	Name	Description
0x0	SINGLEENDED	The ADC is operating in Single-Ended mode where only the positive input is used. The ADC result is presented as an unsigned value.
0x1	DIFF	The ADC is operating in Differential mode where both positive and negative inputs are used. The ADC result is presented as a signed value.

**Bit 4 – LEFTADJ** Left Adjust Result  
 Writing a '1' to this bit will enable left adjustment of the ADC result.

**Bits 3:2 – RESSEL[1:0]** Resolution Selection  
 This bit field selects the ADC resolution. When changing the resolution from 12-bit to 10-bit, the conversion time is reduced from 13.5 CLK\_ADC cycles to 11.5 CLK\_ADC cycles.

Value	Description
0x00	12-bit resolution
0x01	10-bit resolution
Other	Reserved

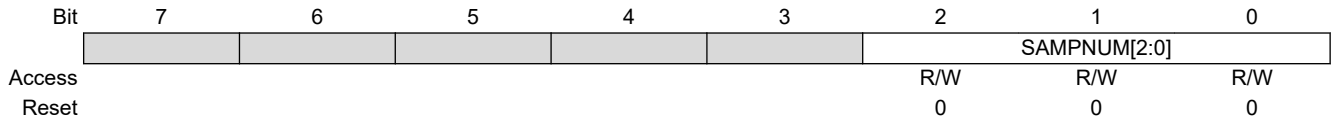
**Bit 1 – FREERUN** Free-Running  
 Writing a '1' to this bit will enable the Free-Running mode for the ADC. The first conversion is started by writing a '1' to the Start Conversion (STCONV) bit in the Command (ADCn.COMMAND) register.

**Bit 0 – ENABLE** ADC Enable

Value	Description
0	ADC is disabled
1	ADC is enabled

### 31.5.2 Control B

**Name:** CTRLB  
**Offset:** 0x01  
**Reset:** 0x00  
**Property:** -



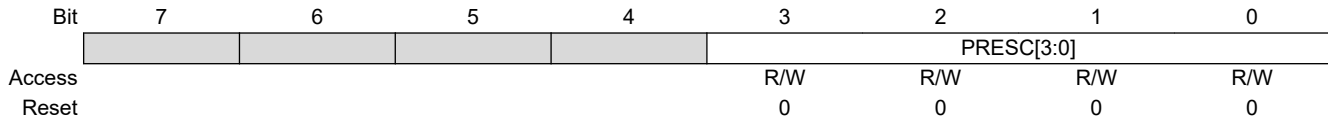
**Bits 2:0 – SAMPNUM[2:0]** Sample Accumulation Number Select

This bit field selects how many consecutive ADC sampling results are accumulated automatically. When this bit field is written to a value greater than 0x0, the according number of consecutive ADC sampling results are accumulated into the ADC Result (ADCn.RES) register.

Value	Name	Description
0x0	NONE	No accumulation
0x1	ACC2	2 results accumulated
0x2	ACC4	4 results accumulated
0x3	ACC8	8 results accumulated
0x4	ACC16	16 results accumulated
0x5	ACC32	32 results accumulated
0x6	ACC64	64 results accumulated
0x7	ACC128	128 results accumulated

### 31.5.3 Control C

**Name:** CTRLC  
**Offset:** 0x02  
**Reset:** 0x00  
**Property:** -



**Bits 3:0 – PRESC[3:0] Prescaler**

This bit field defines the division factor from the peripheral clock (CLK\_PER) to the ADC clock (CLK\_ADC).

Value	Name	Description
0x0	DIV2	CLK_PER divided by 2
0x1	DIV4	CLK_PER divided by 4
0x2	DIV8	CLK_PER divided by 8
0x3	DIV12	CLK_PER divided by 12
0x4	DIV16	CLK_PER divided by 16
0x5	DIV20	CLK_PER divided by 20
0x6	DIV24	CLK_PER divided by 24
0x7	DIV28	CLK_PER divided by 28
0x8	DIV32	CLK_PER divided by 32
0x9	DIV48	CLK_PER divided by 48
0xA	DIV64	CLK_PER divided by 64
0xB	DIV96	CLK_PER divided by 96
0xC	DIV128	CLK_PER divided by 128
0xD	DIV256	CLK_PER divided by 256
Other	-	Reserved

### 31.5.4 Control D

**Name:** CTRLD  
**Offset:** 0x03  
**Reset:** 0x00  
**Property:** -

	7	6	5	4	3	2	1	0
	INITDLY[2:0]				SAMPDLY[3:0]			
Access	R/W	R/W	R/W		R/W	R/W	R/W	R/W
Reset	0	0	0		0	0	0	0

**Bits 7:5 – INITDLY[2:0]** Initialization Delay

This bit field defines the initialization delay before the first sample when enabling the ADC or changing to an internal reference voltage. Setting this delay will ensure that the components of ADC are ready before starting the first conversion. The initialization delay will also be applied when waking up from deep Sleep to do a measurement. The delay is expressed as a number of CLK\_ADC cycles.

Value	Name	Description
0x0	DLY0	Delay 0 CLK_ADC cycles
0x1	DLY16	Delay 16 CLK_ADC cycles
0x2	DLY32	Delay 32 CLK_ADC cycles
0x3	DLY64	Delay 64 CLK_ADC cycles
0x4	DLY128	Delay 128 CLK_ADC cycles
0x5	DLY256	Delay 256 CLK_ADC cycles
Other	-	Reserved

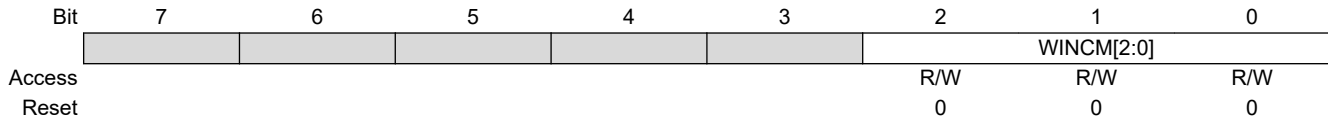
**Bits 3:0 – SAMPDLY[3:0]** Sampling Delay

This bit field defines the delay between consecutive ADC samples. This allows modifying the sampling frequency used during hardware accumulation, to suppress periodic noise that may otherwise disturb the sampling. The delay is expressed as CLK\_ADC cycles and is given directly by the bit field setting.

Value	Name	Description
0x0	DLY0	Delay 0 CLK_ADC cycles
0x1	DLY1	Delay 1 CLK_ADC cycles
0x2	DLY2	Delay 2 CLK_ADC cycles
...	...	
0xF	DLY15	Delay 15 CLK_ADC cycles

### 31.5.5 Control E

**Name:** CTRL E  
**Offset:** 0x04  
**Reset:** 0x00  
**Property:** -



**Bits 2:0 – WINCM[2:0]** Window Comparator Mode

This bit field enables the Window Comparator and defines when the Window Comparator Interrupt Flag (WCMP) in the Interrupt Flags (ADCn.INTFLAGS) register is set. In the table below, RESULT is the accumulated 16-bit result. WINLT and WINHT are the 16-bit lower threshold value and the 16-bit upper threshold value given by the ADCn.WINLT and ADCn.WINHT registers, respectively.

Value	Name	Description
0x0	NONE	No Window Comparison (default)
0x1	BELOW	$RESULT < WINLT$
0x2	ABOVE	$RESULT > WINHT$
0x3	INSIDE	$WINLT \leq RESULT \leq WINHT$
0x4	OUTSIDE	$RESULT < WINLT$ or $RESULT > WINHT$
Other	-	Reserved

**31.5.6 Sample Control**

**Name:** SAMPCTRL  
**Offset:** 0x05  
**Reset:** 0x00  
**Property:** -

	7	6	5	4	3	2	1	0
	SAMPLEN[7:0]							
Access	R/W	R/W	R/W	R/W	R/W	R/W	R/W	R/W
Reset	0	0	0	0	0	0	0	0

**Bits 7:0 – SAMPLEN[7:0] Sample Length**

This bit field extends the ADC sampling time with the number of CLK\_ADC cycles given by the bit field value. Increasing the sampling time allows sampling sources with higher impedance. By default, the sampling time is two CLK\_ADC cycles. The total conversion time increases with the selected sampling length.



### 31.5.7 MUX Selection for Positive ADC Input

**Name:** MUXPOS  
**Offset:** 0x08  
**Reset:** 0x00  
**Property:** -

	7	6	5	4	3	2	1	0
	MUXPOS[6:0]							
Access		R/W	R/W	R/W	R/W	R/W	R/W	R/W
Reset		0	0	0	0	0	0	0

**Bits 6:0 – MUXPOS[6:0]** MUX Selection for Positive ADC Input

This bit field selects which analog input is connected to the positive input of the ADC. If this bit field is changed during a conversion, the change will not take effect until the conversion is complete.

Value	Name	Description
0x00–0x0F	AIN0-AIN15	ADC input pin 0-15
0x10–0x15	AIN16-AIN21	ADC input pin 16-21
0x16–0x3F	-	Reserved
0x40	GND	Ground
0x41	-	Reserved
0x42	TEMPSENSE	Temperature sensor
0x43–0x47	-	Reserved
0x48	DAC0	DAC0
0x49	DACREF0	DACREF0
0x4A	DACREF1	DACREF1
0x4B	DACREF2	DACREF2
Other	-	Reserved

### 31.5.8 MUX Selection for Negative ADC Input

**Name:** MUXNEG  
**Offset:** 0x09  
**Reset:** 0x00  
**Property:** -

	Bit	7	6	5	4	3	2	1	0
		MUXNEG[6:0]							
Access			R/W	R/W	R/W	R/W	R/W	R/W	R/W
Reset			0	0	0	0	0	0	0

**Bits 6:0 – MUXNEG[6:0]** MUX Selection for Negative ADC Input

This bit field selects which analog input is connected to the negative input of the ADC. If this bit field is changed during a conversion, the change will not take effect until the conversion is complete.

Value	Name	Description
0x00–0x0F	AIN0-AIN15	ADC input pin 0-15
0x10–0x3F	-	Reserved
0x40	GND	Ground
0x42–0x47	-	Reserved
0x48	DAC0	DAC0
Other	-	Reserved

**31.5.9 Command**

**Name:** COMMAND  
**Offset:** 0x0A  
**Reset:** 0x00  
**Property:** -

	7	6	5	4	3	2	1	0
Access							R/W	R/W
Reset							0	0

**Bit 1 – SPCONV** Stop Conversion  
 Writing a '1' to this bit will end the current measurement. This bit will take precedence over the Start Conversion (STCONV) bit. Writing a '0' to this bit has no effect.

**Bit 0 – STCONV** Start Conversion  
 Writing a '1' to this bit will start a conversion as soon as any ongoing conversions are completed. If in Free-Running mode, this will start the first conversion. STCONV will read as '1' as long as a conversion is in progress. When the conversion is complete, this bit is automatically cleared. Writing a '0' to this bit has no effect.

31.5.10 Event Control

Name: EVCTRL  
Offset: 0x0B  
Reset: 0x00  
Property: -

Bit	7	6	5	4	3	2	1	0
Access								STARTEI
Reset								0

**Bit 0 – STARTEI** Start Event Input

This bit enables the event input as trigger for starting a conversion. When a '1' is written to this bit, a rising event edge will trigger an ADC conversion.

31.5.11 Interrupt Control

**Name:** INTCTRL  
**Offset:** 0x0C  
**Reset:** 0x00  
**Property:** -

Bit	7	6	5	4	3	2	1	0
							WCMP	RESRDY
Access							R/W	R/W
Reset							0	0

**Bit 1 – WCMP** Window Comparator Interrupt Enable  
Writing a '1' to this bit enables the window comparator interrupt.

**Bit 0 – RESRDY** Result Ready Interrupt Enable  
Writing a '1' to this bit enables the Result Ready interrupt.

### 31.5.12 Interrupt Flags

**Name:** INTFLAGS  
**Offset:** 0x0D  
**Reset:** 0x00  
**Property:** -

	7	6	5	4	3	2	1	0
							WCMP	RESRDY
Access							R/W	R/W
Reset							0	0

**Bit 1 – WCMP** Window Comparator Interrupt Flag

This window comparator flag is set when the measurement is complete and if the result matches the selected Window Comparator mode defined by the WINCM bit field in the Control E (ADCn.CTRLE) register. The comparison is done at the end of the conversion. The flag is cleared by either writing a '1' to the bit position or by reading the Result (ADCn.RES) register. Writing a '0' to this bit has no effect.

**Bit 0 – RESRDY** Result Ready Interrupt Flag

The Result Ready interrupt flag is set when a measurement is complete and a new result is ready. The flag is cleared by either writing a '1' to the bit location or by reading the Result (ADCn.RES) register. Writing a '0' to this bit has no effect.

31.5.13 Debug Control

Name: DBGCTRL  
Offset: 0x0E  
Reset: 0x00  
Property: -

Bit	7	6	5	4	3	2	1	0
Access								DBGRUN
Reset								0

**Bit 0 – DBGRUN** Run in Debug Mode

When written to '1', the peripheral will continue operating in Debug mode when the CPU is halted.

### 31.5.14 Temporary

**Name:** TEMP  
**Offset:** 0x0F  
**Reset:** 0x00  
**Property:** -

The Temporary register is used by the CPU for 16-bit single-cycle access to the 16-bit registers of this peripheral. The register is common for all the 16-bit registers of this peripheral and can be read and written by software. For more details on reading and writing 16-bit registers, refer to *Accessing 16-Bit Registers* in the *Memories* section.

	7	6	5	4	3	2	1	0
	TEMP[7:0]							
Access	R/W	R/W	R/W	R/W	R/W	R/W	R/W	R/W
Reset	0	0	0	0	0	0	0	0

**Bits 7:0 – TEMP[7:0]** Temporary

Temporary register for read and write operations to and from 16-bit registers.



### 31.5.15 Result

**Name:** RES  
**Offset:** 0x10  
**Reset:** 0x00  
**Property:** -

The ADCn.RESL and ADCn.RESH register pair represents the 16-bit value, ADCn.RES. The low byte [7:0] (suffix L) is accessible at the original offset. The high byte [15:8] (suffix H) can be accessed at offset + 0x01.

Refer to the [31.3.3.5 Conversion Result \(Output Formats\)](#) section for details on the output from this register.

Bit	15	14	13	12	11	10	9	8
	RES[15:8]							
Access	R	R	R	R	R	R	R	R
Reset	0	0	0	0	0	0	0	0
Bit	7	6	5	4	3	2	1	0
	RES[7:0]							
Access	R	R	R	R	R	R	R	R
Reset	0	0	0	0	0	0	0	0

**Bits 15:8 – RES[15:8] Result High Byte**

This bit field constitutes the high byte of the ADCn.RES register, where the MSb is RES[15].

**Bits 7:0 – RES[7:0] Result Low Byte**

This bit field constitutes the low byte of the ADCn.RES register.

### 31.5.16 Window Comparator Low Threshold

**Name:** WINLT  
**Offset:** 0x12  
**Reset:** 0x00  
**Property:** -

This register is the 16-bit low threshold for the digital comparator monitoring the Result (ADCn.RES) register. The data format must be according to the Conversion mode and left/right adjustment setting.

The ADCn.WINLTH and ADCn.WINLTL register pair represents the 16-bit value, ADCn.WINLT. The low byte [7:0] (suffix L) is accessible at the original offset. The high byte [15:8] (suffix H) can be accessed at offset + 0x01.

Bit	15	14	13	12	11	10	9	8
	WINLT[15:8]							
Access	R/W	R/W	R/W	R/W	R/W	R/W	R/W	R/W
Reset	0	0	0	0	0	0	0	0
Bit	7	6	5	4	3	2	1	0
	WINLT[7:0]							
Access	R/W	R/W	R/W	R/W	R/W	R/W	R/W	R/W
Reset	0	0	0	0	0	0	0	0

**Bits 15:8 – WINLT[15:8]** Window Comparator Low Threshold High Byte  
This bit field holds the MSB of the 16-bit register.

**Bits 7:0 – WINLT[7:0]** Window Comparator Low Threshold Low Byte  
This bit field holds the LSB of the 16-bit register.

### 31.5.17 Window Comparator High Threshold

**Name:** WINHT  
**Offset:** 0x14  
**Reset:** 0x00  
**Property:** -

This register is the 16-bit high threshold for the digital comparator monitoring the Result (ADCn.RES) register. The data format must be according to the Conversion mode and left/right adjustment setting.

The ADCn.WINHTH and ADCn.WINHTL register pair represents the 16-bit value, ADCn.WINHT. The low byte [7:0] (suffix L) is accessible at the original offset. The high byte [15:8] (suffix H) can be accessed at offset + 0x01.

Bit	15	14	13	12	11	10	9	8
	WINHT[15:8]							
Access	R/W	R/W	R/W	R/W	R/W	R/W	R/W	R/W
Reset	0	0	0	0	0	0	0	0
Bit	7	6	5	4	3	2	1	0
	WINHT[7:0]							
Access	R/W	R/W	R/W	R/W	R/W	R/W	R/W	R/W
Reset	0	0	0	0	0	0	0	0

**Bits 15:8 – WINHT[15:8]** Window Comparator High Threshold High Byte  
This bit field holds the MSB of the 16-bit register.

**Bits 7:0 – WINHT[7:0]** Window Comparator High Threshold Low Byte  
This bit field holds the LSB of the 16-bit register.

## 32. DAC - Digital-to-Analog Converter

### 32.1 Features

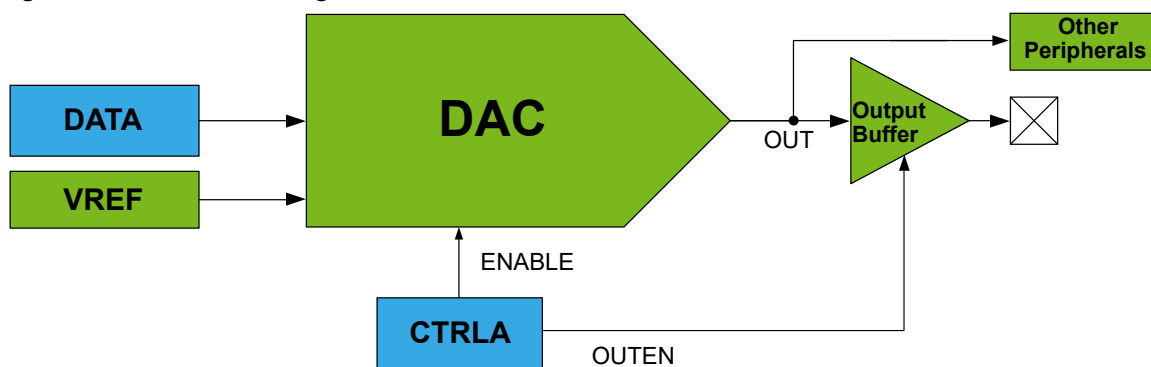
- 10-bit Resolution
- Up to 140 ksp/s Conversion Rate
- High Drive Capabilities
- The DAC Output Can Be Used as Input to the ADC Positive Input

### 32.2 Overview

The Digital-to-Analog Converter (DAC) converts a digital value written to the Data (DACn.DATA) register to an analog voltage. The conversion range is between GND and the selected voltage reference in the Voltage Reference (VREF) peripheral. The DAC has one continuous time output with high drive capabilities. The DAC conversion can be started from the application by writing to the Data (DACn.DATA) register.

#### 32.2.1 Block Diagram

Figure 32-1. DAC Block Diagram



#### 32.2.2 Signal Description

Signal	Description	Type
OUT	DAC output	Analog

### 32.3 Functional Description

#### 32.3.1 Initialization

To operate the DAC, the following steps are required:

1. Select the DAC reference voltage in the Voltage Reference (VREF) peripheral by writing the appropriate Reference Selection bits.
2. Configure the further usage of the DAC output:
  - Configure an internal peripheral to use the DAC output. Refer to the documentation of the respective peripherals.
  - Enable the output to a pin by writing a '1' to the Output Buffer Enable (OUTEN) bit. The input for the DAC pin must be disabled in the Port peripheral (ISC = INPUT\_DISABLE in PORTx.PINCTRLn).
3. Write an initial digital value to the Data (DACn.DATA) register.

4. Enable the DAC by writing a '1' to the ENABLE bit in the Control A (DACn.CTRLA) register.

### **32.3.2 Operation**

#### **32.3.2.1 Enabling, Disabling and Resetting**

The DAC is enabled by writing a '1' to the ENABLE bit in the Control A (DACn.CTRLA) register, and disabled by writing a '0' to this bit.

#### **32.3.2.2 Starting a Conversion**

When the ENABLE bit in the Control A (DACn.CTRLA) register is written to '1', a conversion starts as soon as the Data (DACn.DATA) register is written.

When the ENABLE bit in DACn.CTRLA is written to '0', writing to the Data register does not trigger a conversion. Instead, the conversion starts when the ENABLE bit in DACn.CTRLA is written to '1'.

#### **32.3.2.3 DAC as Source For Internal Peripherals**

The analog output of the DAC can be internally connected to other peripherals when the ENABLE bit in the Control A (DACn.CTRLA) register is written to '1'. When the DAC analog output is only being used internally, the Output Buffer Enable (OUTEN) bit in DACn.CTRLA can be '0'.

#### **32.3.2.4 DAC Output on Pin**

The analog output of the DAC can be connected to a pin by writing a '1' to the Output Buffer Enable (OUTEN) bit in the Control A (DACn.CTRLA) register. The pin used by the DAC must have the input disabled from the Port peripheral. There is an output buffer between the DAC output and the pin, which ensures the analog value does not depend on the load of the pin. The output buffer can only source current, since it has very limited sinking capability.

### **32.3.3 Sleep Mode Operation**

If the Run in Standby (RUNSTDBY) bit in the Control A (DACn.CTRLA) register is written to '1', the DAC will continue to operate in Standby sleep mode. If the RUNSTDBY bit is zero, the DAC will stop the conversion in Standby sleep mode.

If the conversion is stopped in Standby sleep mode, the DAC and the output buffer are disabled to reduce power consumption. When the device is exiting Standby sleep mode, the DAC and the output buffer (if the OUTEN bit in the Control A (DACn.CTRLA) register is written to '1') are enabled again. Therefore, a start-up time is required before a new conversion is initiated.

In Power-Down sleep mode, the DAC and the output buffer are disabled to reduce power consumption.

### 32.4 Register Summary

Offset	Name	Bit Pos.	7	6	5	4	3	2	1	0
0x00	<a href="#">CTRLA</a>	7:0	RUNSTDBY	OUTEN						ENABLE
0x01	Reserved									
0x02	<a href="#">DATA</a>	7:0	DATA[1:0]							
		15:8	DATA[9:2]							

### 32.5 Register Description

**32.5.1 Control A**

**Name:** CTRLA  
**Offset:** 0x00  
**Reset:** 0x00  
**Property:** -

	7	6	5	4	3	2	1	0
	RUNSTDBY	OUTEN						ENABLE
Access	R/W	R/W						R/W
Reset	0	0						0

**Bit 7 – RUNSTDBY** Run in Standby Mode

If this bit is written to '1', the DAC or the output buffer will not automatically be disabled when the device is entering Standby sleep mode.

**Bit 6 – OUTEN** Output Buffer Enable

Writing a '1' to this bit enables the output buffer and sends the OUT signal to a pin.

**Bit 0 – ENABLE** DAC Enable

Writing a '1' to this bit enables the DAC.

### 32.5.2 DATA

**Name:** DATA  
**Offset:** 0x02  
**Reset:** 0x00  
**Property:** -

The DACn.DATAL and DACn.DATAH register pair represents the 10-bit value, DACn.DATA. The two LSBs [1:0] are accessible at the original offset. The eight MSBs [9:2] can be accessed at offset + 0x01.

The output will be updated after DACn.DATAH is written.

	Bit	15	14	13	12	11	10	9	8
		DATA[9:2]							
Access		R/W	R/W	R/W	R/W	R/W	R/W	R/W	R/W
Reset		0	0	0	0	0	0	0	0
	Bit	7	6	5	4	3	2	1	0
		DATA[1:0]							
Access		R/W	R/W						
Reset		0	0						

#### Bits 15:6 – DATA[9:0]

These bits contain the digital data, which will be converted to an analog voltage.



## 33. PTC - Peripheral Touch Controller

### 33.1 Features

- Low-Power, High-Sensitivity, Environmentally Robust Capacitive Touch Buttons, Sliders, Wheels and 2D Surface
- Supports Wake-up on Touch from Standby Sleep Mode
- Supports Mix-and-Match Mutual and Self-Capacitance Sensing
  - 18/22/32/46 buttons in Self-Capacitance mode, for 28-/32-/48-/64-pins, respectively
  - 81/121/256/529 buttons in Mutual Capacitance mode, for 28-/32-/48-/64-pins, respectively
- One Pin per Electrode – No External Components
- Load Compensating Charge Sensing:
  - Parasitic capacitance compensation
  - Adjustable gain for superior sensitivity
- Zero Drift Over the Temperature and  $V_{DD}$  Range:
  - Auto-calibration and recalibration of sensors
- Single-Shot and Free-Running Charge Measurement
- Hardware Noise Filtering and Noise Signal Desynchronization for High Conducted Immunity
- Supports Analog Accumulation and Digital Accumulation
- Driven Shield+ for Superior Noise Immunity and Moisture Tolerance
  - Any PTC X/Y line can be used for the driven shield
  - All enabled sensors will be driven at the same potential as the sensor scanned
- Boost Mode for Doubled Signal-to-Noise Ratio or 4x Faster Response Time in Mutual Capacitance Systems
- Selectable Channel Change Delay Allows Choosing the Settling Time on a New Channel, as Required
- Acquisition-Start Triggered by Command or through Auto-Triggering Feature
- Low CPU Utilization through Interrupt on Acquisition-Complete
- Supported by the START QTouch® Configurator Development Tools
- Window Monitor to Compare Value to Predefined Threshold Values

### 33.2 Overview

The Peripheral Touch Controller (PTC) acquires signals to detect a touch on capacitive sensors. The external capacitive touch sensor is typically formed on a PCB or a transparent substrate with a transparent or translucent material such as indium tin oxide (ITO) or PEDOT. An increasingly popular implementation is printing the sensor electrodes directly on the backside of the touch surface using conductive inks. The sensor electrodes are connected to the analog front end of the PTC through the I/O pins in the device. The PTC supports both mutual and self-capacitance sensors.

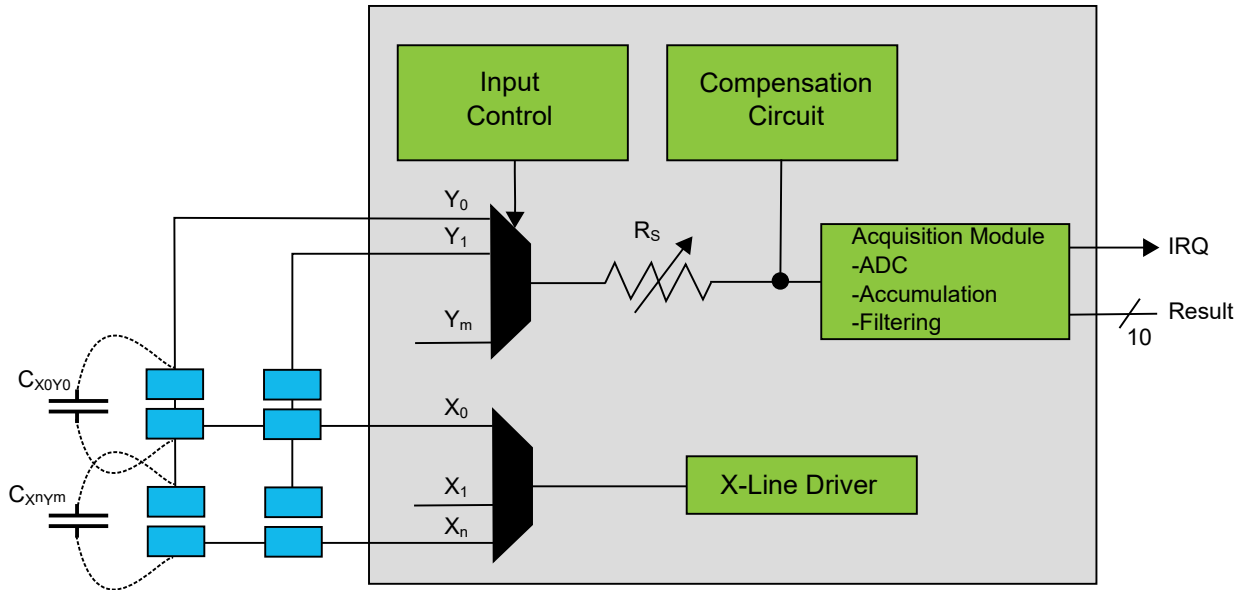
In Mutual Capacitance mode, sensing is done using capacitive touch matrices in various X-Y configurations. The PTC requires one pin per X-line and one pin per Y-line. See [Figure 33-1](#).

In Self-Capacitance mode, the PTC requires one pin (Y-line) for each touch sensor. See [Figure 33-2](#).

The number of available pins and the assignment of X- and Y-lines depend on both package type and device configuration.

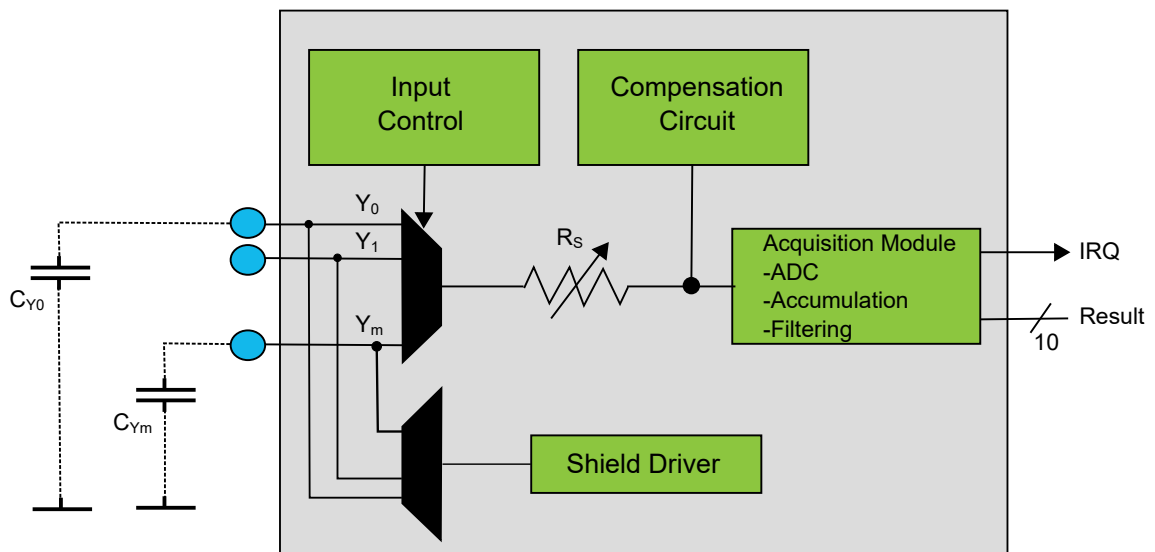
### 33.3 Block Diagram

Figure 33-1. PTC Block Diagram in Mutual Capacitance Mode



**Note:** For AVR128DA28/32/48/64 the  $R_S = 0, 20, 50, 100 \text{ k}\Omega$ .

Figure 33-2. PTC Block Diagram in Self-Capacitance Mode



**Note:** For AVR128DA28/32/48/64 the  $R_S = 0, 20, 50, 100 \text{ k}\Omega$ .

**Note:** The internal series resistor,  $R_S$ , has limited effect in Self-Capacitance mode. It is always recommended to add an external series resistor.

### 33.4 Signal Description

**Table 33-1. Signal Description**

Name	Type	Description
Y[m:0]	Analog	Y-line (Input/Output)
X[n:0]	Digital	X-line (Output)

**Note:** The number of X- and Y-lines are device-dependent. Refer to the *Family Overview* section for details.

For available pins and functionalities, refer to the *I/O Multiplexing and Considerations* section in the device data sheet.

### 33.5 System Dependencies

To use this peripheral, configure the other components of the system, as described in the following sections.

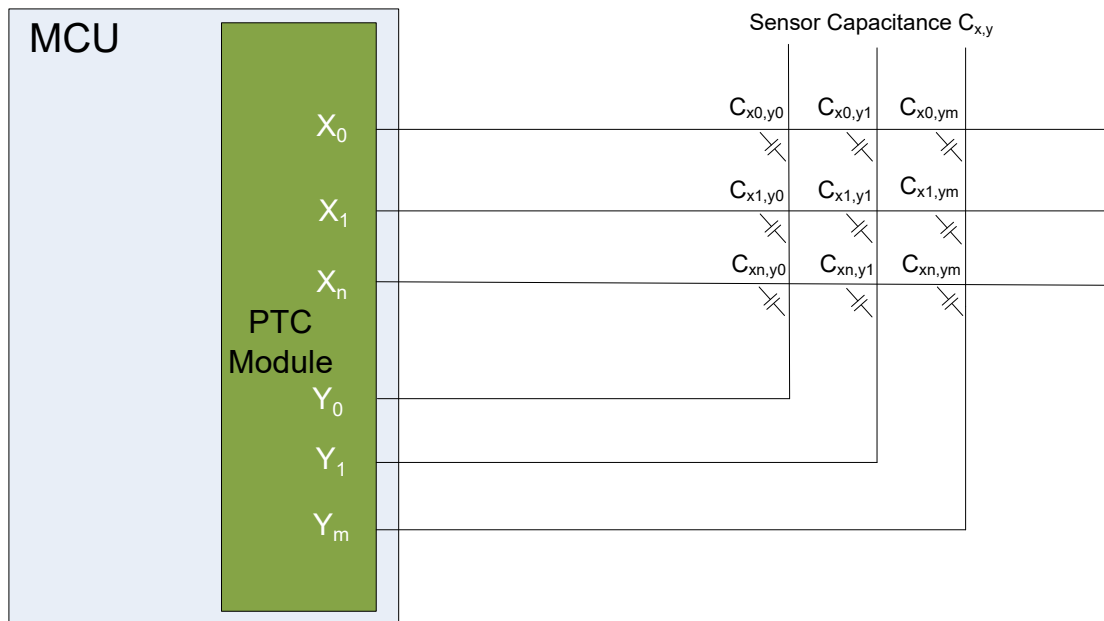
#### 33.5.1 I/O Lines

The I/O lines used for analog X- and Y-lines must be connected to external capacitive touch sensor electrodes. External components are not required for normal operation, however, to improve EMC susceptibility, a series resistor of up to 100 kΩ can be added to the Y-lines. In Mutual Capacitance mode, a series resistor of up to 10 kΩ can be added to the X-lines to reduce EMC emissions.

##### 33.5.1.1 Mutual Capacitance Sensor Arrangement

A mutual capacitance sensor is formed between two I/O lines - an X-electrode for transmitting and a Y-electrode for sensing. The mutual capacitance between the X- and Y-electrodes is measured by the PTC.

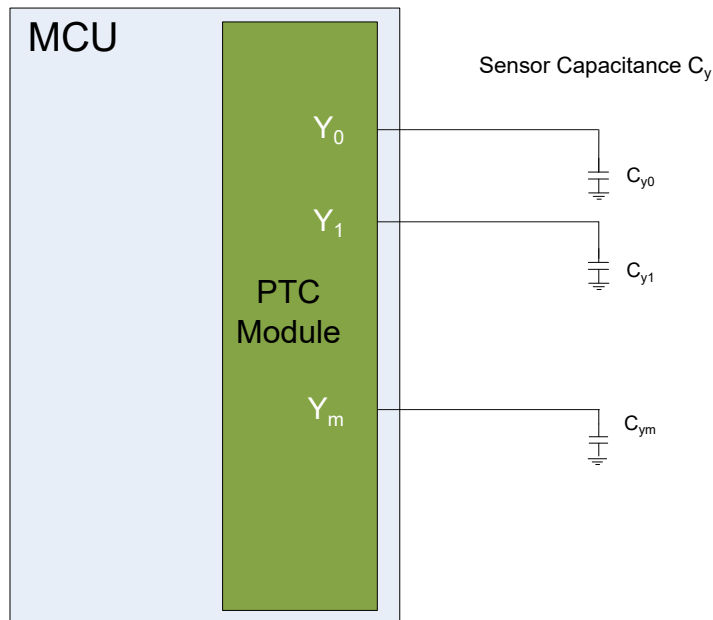
**Figure 33-3. Mutual Capacitance Sensor Arrangement**



##### 33.5.1.2 Self-Capacitance Sensor Arrangement

A self-capacitance sensor is connected to a single pin on the PTC through the Y-electrode. The sense electrode capacitance is measured by the PTC.

Figure 33-4. Self-Capacitance Sensor Arrangement



For more information about designing the touch sensor, refer to the AN2934, “Capacitive Touch Sensor Design Guide (DS00002934)”.

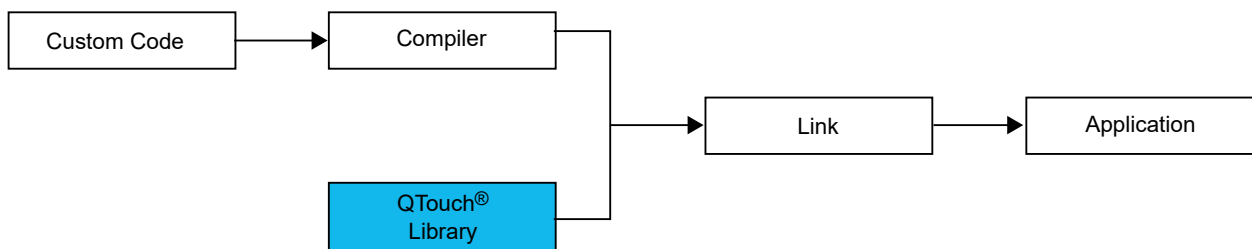
### 33.5.2 Clocks

The PTC is clocked by the internal PTC-ADC clock or by the CLK\_PER clock. Refer to the *Clock Controller* section for considerations on configuring the CLK\_PER.

## 33.6 Functional Description

To access the PTC, the START QTouch Configurator must be used to configure the QTouch Library and link it to the application software. The QTouch Library can be used to implement buttons, sliders and wheels in a variety of combinations on a single interface.

Figure 33-5. QTouch® Library Usage



For more information about QTouch Library, refer to the “QTouch® Modular Library Peripheral Touch Controller User's Guide (DS40001986)”.

## 34. ZCD - Zero-Cross Detector

### 34.1 Features

- Detect Zero-Crossings on High-Voltage Alternating Signals
- Only One External Resistor Required
- The Detector Output is Available on a Pin
- The Polarity of the Detector Output can be Inverted
- Interrupt Generation on:
  - Rising edge
  - Falling edge
  - Both edges
- Event Generation:
  - Detector output

### 34.2 Overview

The Zero-Cross Detector (ZCD) detects when an alternating voltage crosses through a threshold voltage near the ground potential. The threshold is the zero-cross reference voltage,  $Z_{CPINV}$ , and the typical value can be found in the *Electrical Specifications* section of the peripheral.

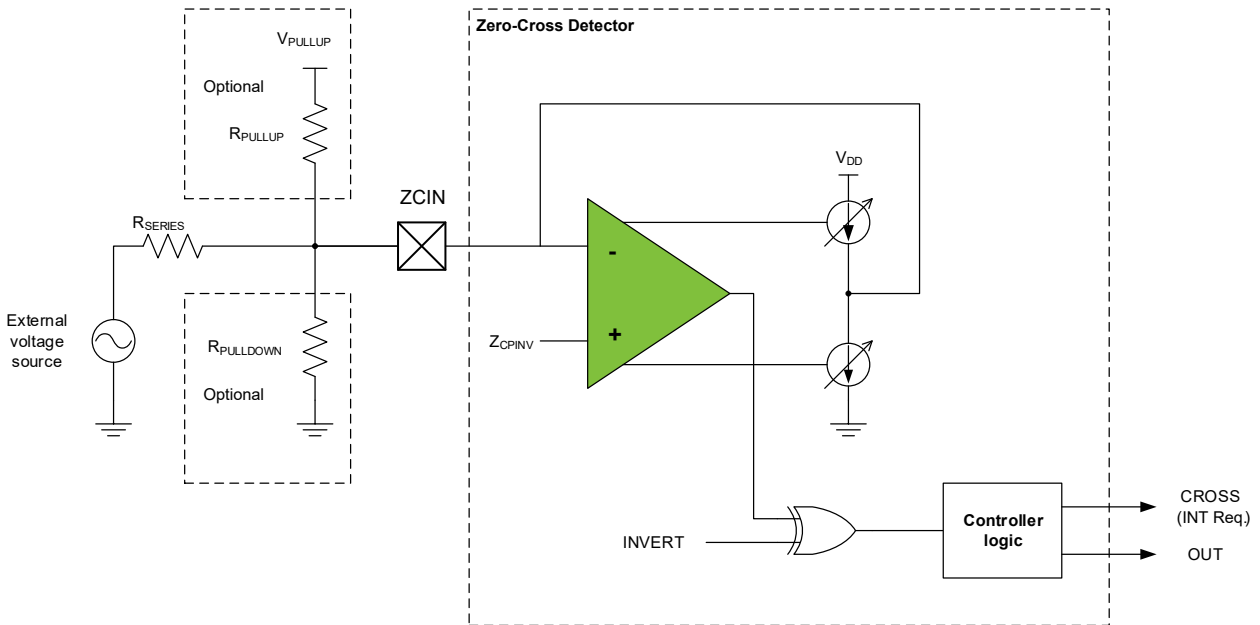
The connection from the ZCD input pin (ZCIN) to the alternating voltage must be made through a series current-limiting resistor ( $R_{SERIES}$ ). The ZCD applies either a current source or sink to the ZCD input pin to maintain a constant voltage on the pin, thereby preventing the pin voltage from forward biasing the ESD protection diodes in the device. When the applied voltage is greater than the reference voltage, the ZCD sinks current. When the applied voltage is less than the reference voltage, the ZCD sources current.

The ZCD can be used when monitoring an alternating waveform for, but not limited to, the following purposes:

- Period Measurement
- Accurate Long-Term Time Measurement
- Dimmer Phase-Delayed Drive
- Low-EMI Cycle Switching

34.2.1 Block Diagram

Figure 34-1. Zero-Cross Detector



34.2.2 Signal Description

Signal	Description	Type
ZCIN	Input	Analog
OUT	Output	Digital

34.3 Functional Description

34.3.1 Initialization

For basic operation, follow these steps:

- Configure the desired input pin in the PORT peripheral as an analog pin with digital input buffer disabled. Internal pull-up and pull-down resistors must also be disabled.
- Optional: Enable the output pin by writing a '1' to the Output Enable (OUTEN) bit in the Control A (ZCDn.CTRLA) register.
- Enable the ZCD by writing a '1' to the ENABLE bit in ZCDn.CTRLA

After the ZCD is enabled, there is a start-up time during which the output of the ZCD may be invalid. The start-up time can be determined by referring to the ZCD electrical characteristics for the device.

34.3.2 Operation

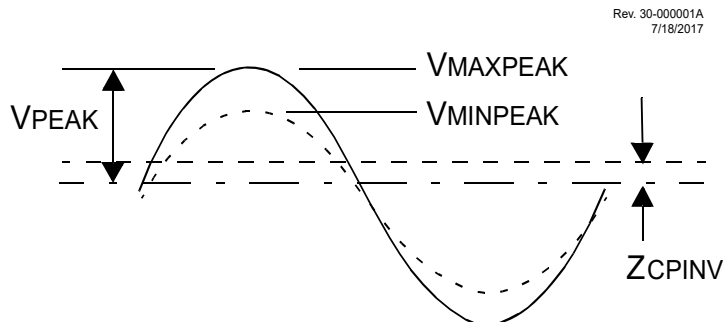
34.3.2.1 External Resistor Selection

The ZCD requires a current-limiting resistor in series ( $R_{SERIES}$ ) with the external voltage source. If the peak amplitude ( $V_{PEAK}$ ) of the external voltage source is expected to be stable, the resistor value must be chosen such that an  $I_{ZCD\_MAX}/2$  resistor current results in a voltage drop equal to the expected peak voltage. The power rating of the resistor should be at least the mean square voltage divided by the resistor value. (How to handle a peak voltage that varies between a minimum ( $V_{MINPEAK}$ ) and maximum ( $V_{MAXPEAK}$ ) value is described in the section below on **Handling  $V_{PEAK}$  Variations.**)

**Equation 34-1. External Resistor**

$$R_{SERIES} = \frac{V_{PEAK}}{3 \times 10^{-4}}$$

**Figure 34-2. External Voltage Source**



**34.3.2.2 ZCD Logic Output**

The STATE flag in the ZCDn.STATUS register indicates whether the input signal is above or below the reference voltage, ZCPINV. By default, the STATE flag is '1' when the input signal is above the reference voltage and '0' when the input signal is below the reference voltage. The polarity of the STATE flag can be reversed by writing the INVERT bit to '1' in the ZCDn.CTRLA register. The INVERT bit will also affect ZCD interrupt polarity.

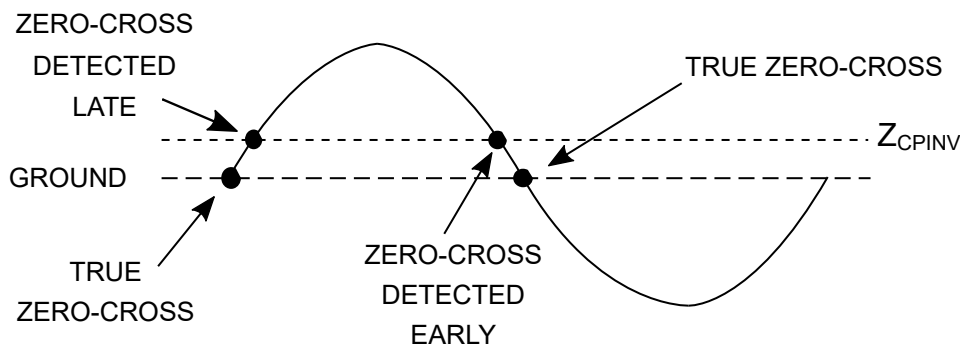
**34.3.2.3 Correction for ZCPINV Offset**

The actual voltage at which the ZCD switches is the zero-cross reference voltage. Because this reference voltage is slightly offset from the ground, the zero-cross event generated by the ZCD will occur either early or late for the true zero-crossing.

**34.3.2.3.1 Correction By Offset Current**

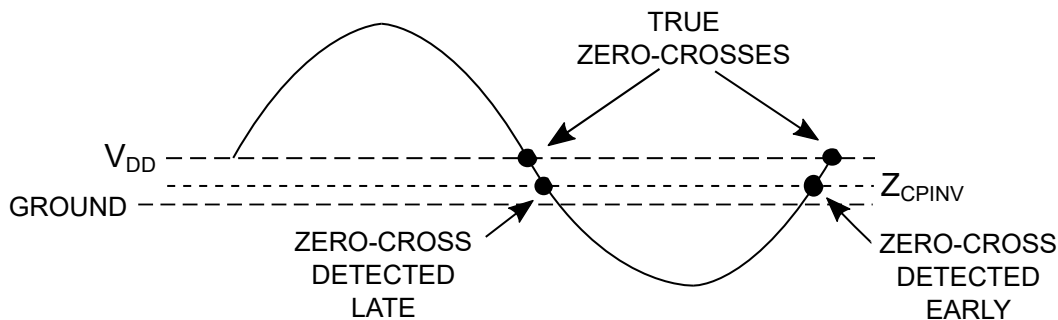
When the alternating waveform is referenced to the ground, as shown in the figure below, the zero-cross is detected too late as the waveform rises and too early as the waveform falls.

**Figure 34-3. Sine Wave Referenced to Ground**



When the waveform is referenced to VDD, as shown in the figure below, the zero-cross is detected too late as the waveform falls and too early as the waveform rises.

Figure 34-4. Sine Wave Referenced to V<sub>DD</sub>



The actual offset time can be determined for sinusoidal waveforms of a known frequency  $f$  using the equations shown below.

**Equation 34-2. ZCD Event Offset**

When the External Voltage source is referenced to ground

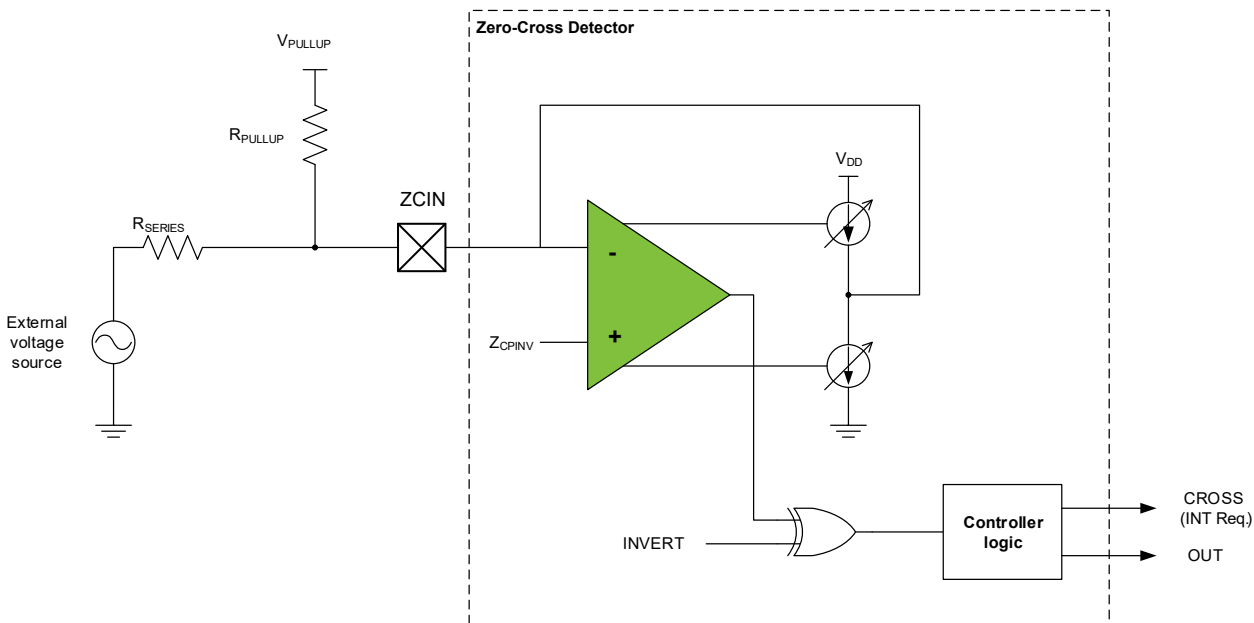
$$T_{offset} = \frac{\sin^{-1}\left(\frac{Z_{CPINV}}{V_{PEAK}}\right)}{2\pi f}$$

When the External Voltage source is referenced to V<sub>DD</sub>

$$T_{offset} = \frac{\sin^{-1}\left(\frac{V_{DD} - Z_{CPINV}}{V_{PEAK}}\right)}{2\pi f}$$

This offset time can be compensated by adding a pull-up or pull-down biasing resistor to the ZCD input pin. A pull-up resistor is used when the external voltage source is referenced to ground, as shown in the figure below.

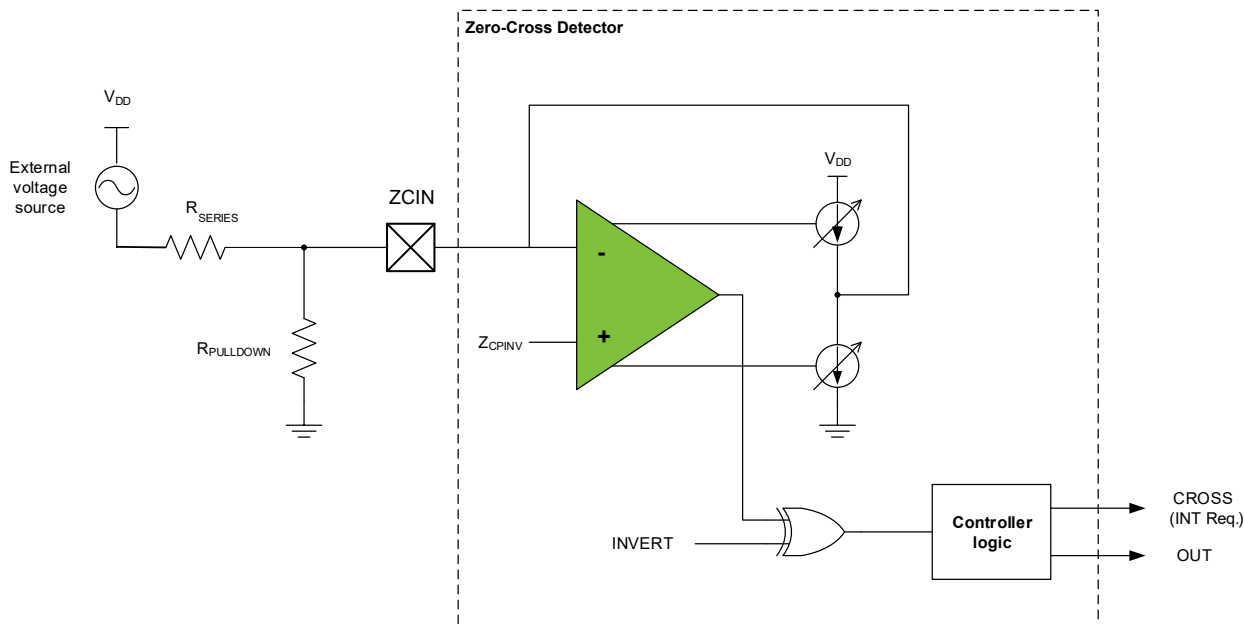
Figure 34-5. External Voltage Source Referenced to Ground



A pull-down resistor is used when the voltage is referenced to V<sub>DD</sub>, as shown in the figure below.



Figure 34-6. External Voltage Source Referenced to V<sub>DD</sub>



The resistor adds a bias to the ZCD input pin so that the external voltage source must go to zero to pull the pin voltage to the Z<sub>CPINV</sub> switching voltage. The pull-up or pull-down value can be determined with the equations shown below.

**Equation 34-3. ZCD Pull-up/Pull-down Resistor**

When the External Voltage source is referenced to ground

$$R_{pullup} = \frac{R_{SERIES}(V_{pullup} - Z_{CPINV})}{Z_{CPINV}}$$

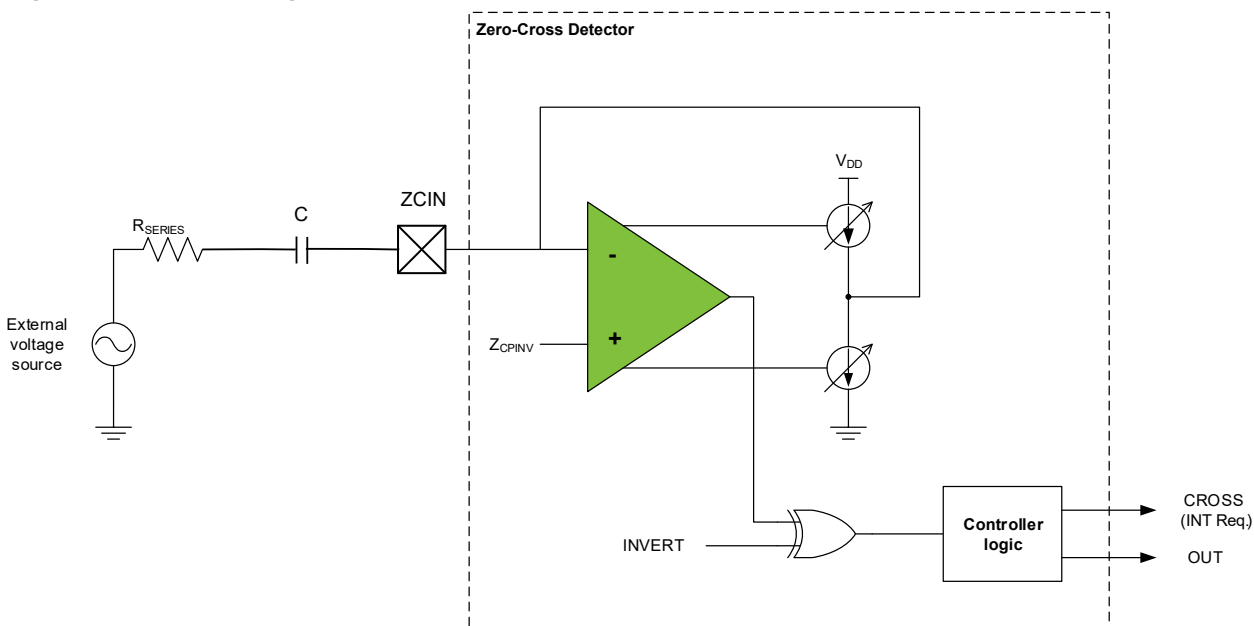
When the External Voltage source is referenced to V<sub>DD</sub>

$$R_{pulldown} = \frac{R_{SERIES}(Z_{CPINV})}{(V_{DD} - Z_{CPINV})}$$

**34.3.2.3.2 Correction by AC Coupling**

When the external voltage source is sinusoidal, the effects of the Z<sub>CPINV</sub> offset can be eliminated by isolating the external voltage source from the ZCD input pin with a capacitor in series with the current-limiting resistor, as shown in the figure below.

Figure 34-7. AC Coupling the ZCD



The phase shift resulting from the capacitor will cause the ZCD output to switch in advance of the actual zero-crossing event. The phase shift will be the same for both rising and falling zero-crossings, which can be compensated for by either delaying the CPU response to the ZCD switch by a timer or other means or selecting a capacitor value large enough that the phase shift is negligible.

To determine the series resistor and capacitor values for this configuration, start by computing the impedance,  $Z$ , to obtain a peak current of  $I_{ZCD\_MAX}/2$ . Next, select a suitably large non-polarized capacitor and compute its reactance,  $X_C$ , at the external voltage source frequency. Finally, compute the series resistor ( $R_{SERIES}$ ), capacitor peak voltage, and phase shift by using the formulas shown below.

When this technique is used, and the input signal is not present, the ZCD may oscillate. Oscillation can be prevented by connecting the ZCD input pin to ground with a high-value resistor such as 200 k $\Omega$ , but this resistor will introduce an offset in the detection of the zero-cross event.

#### Equation 34-4. R-C Equations

$V_{PEAK}$  = External voltage source peak voltage

$f$  = External voltage source frequency

$C$  = Series capacitor

$R$  = Series resistor

$V_C$  = Peak capacitor voltage

$\Phi$  = Capacitor-induced zero-crossing phase advance in radians

$T_\Phi$  = Time zero-cross event occurs before actual zero-crossing

$$Z = \frac{V_{PEAK}}{3 \times 10^{-4}}$$

$$X_C = \frac{1}{2\pi f C}$$

$$R = \sqrt{Z^2 - X_C^2}$$

$$V_C = X_C(3 \times 10^{-4})$$

$$\Phi = \tan^{-1}\theta\left(\frac{X_C}{R}\right)$$

$$T_\Phi = \frac{\Phi}{2\pi f}$$

**Equation 34-5. R-C Calculation Example**

$$V_{rms} = 120$$

$$V_{PEAK} = V_{rms} \times \sqrt{2} = 169.7$$

$$f = 60 \text{ Hz}$$

$$C = 0.1 \mu F$$

$$Z = \frac{V_{PEAK}}{3 \times 10^{-4}} = \frac{169.7}{3 \times 10^{-4}} = 565.7 \text{ k}\Omega$$

$$X_C = \frac{1}{2\pi f C} = \frac{1}{2\pi \times 60 \times 10^{-7}} = 26.53 \text{ k}\Omega$$

$$R = \sqrt{Z^2 - X_C^2} = 565.1 \text{ k}\Omega \text{ (computed)}$$

$$R_a = 560 \text{ k}\Omega \text{ (used)}$$

$$Z_R = \sqrt{R_a^2 + X_C^2} = 560.6 \text{ k}\Omega$$

$$I_{PEAK} = \frac{V_{PEAK}}{Z_R} = 302.7 \times 10^{-6} \text{ A}$$

$$V_C = X_C \times I_{PEAK} = 8.0 \text{ V}$$

$$\Phi = \tan^{-1}\theta\left(\frac{X_C}{R}\right) = 0.047 \text{ radians}$$

$$T_\Phi = \frac{\Phi}{2\pi f} = 125.6 \mu s$$

**34.3.2.4 Handling  $V_{PEAK}$  Variations**

If the peak amplitude of the external voltage is expected to vary, the series resistor ( $R_{SERIES}$ ) must be selected to keep the ZCD source and sink currents below the absolute maximum rating of  $\pm I_{ZCD\_MAX}$  and above a reasonable minimum range. A general rule of thumb for the ZCD is that the maximum peak voltage should be no more than six times the minimum peak voltage. To ensure that the maximum current does not exceed  $\pm I_{ZCD\_MAX}$  and the minimum is at least  $I_{ZCD\_MAX}/6$ , compute the series resistance, as shown in the equation below. The compensating pull-up or pull-down for this series resistance can be determined using the **ZCD Pull-up/Pull-down Resistor** equations shown earlier, as the pull-up/pull-down resistor value is independent of the peak voltage.

**Equation 34-6. Series Resistor for External Voltage Range**

$$R_{SERIES} = \frac{V_{MAXPEAK} + V_{MINPEAK}}{7 \times 10^{-4}}$$

**34.3.3 Events**

The ZCD can generate the following events:

Table 34-1. ZCD Event Generator

Generator Name		Description	Event Type	Generating Clock Domain	Length of Event
Peripheral	Event				
ZCDn	OUT	ZCD output level	Level	Asynchronous	Determined by the ZCD output level

The ZCD has no event inputs. Refer to the Event System (EVSYS) section for more details regarding event types and Event System configuration.

### 34.3.4 Interrupts

Table 34-2. Available Interrupt Vectors and Sources

Name	Vector Description	Conditions
CROSS	ZCD interrupt	Zero-cross detection as configured by INTMODE in ZCDn.INTCTRL and INVERT in ZCDn.CTRLA

When a ZCD interrupt condition occurs, the CROSSIF flag is set in the Status (ZCDn.STATUS) register.

ZCD interrupts are enabled or disabled by writing to the INTMODE field in the Interrupt Control (ZCDn.INTCTRL) register.

A ZCD interrupt request is generated when the interrupt source is enabled, and the CROSSIF flag is set. The interrupt request remains active until the interrupt flag is cleared. See the ZCDn.STATUS register description for details on how to clear interrupt flags.

### 34.3.5 Sleep Mode Operation

In Idle sleep mode, the ZCD will continue to operate as normal.

In Standby sleep mode, the ZCD is disabled by default. If the Run in Standby (RUNSTDBY) bit in the Control A (ZCDn.CTRLA) register is written to '1', the ZCD will continue to operate as normal with interrupt generation, event generation, and ZCD output on pin even if CLK\_PER is not running in Standby sleep mode.

In Power Down sleep mode, the ZCD is disabled, including its output to pin.

### 34.4 Register Summary

Offset	Name	Bit Pos.	7	6	5	4	3	2	1	0
0x00	<a href="#">CTRLA</a>	7:0	RUNSTDBY	OUTEN			INVERT			ENABLE
0x01	Reserved									
0x02	<a href="#">INTCTRL</a>	7:0							INTMODE[1:0]	
0x03	<a href="#">STATUS</a>	7:0				STATE				CROSSIF

### 34.5 Register Description

**34.5.1 Control A**

**Name:** CTRLA  
**Offset:** 0x00  
**Reset:** 0x00  
**Property:** -

Bit	7	6	5	4	3	2	1	0
	RUNSTDBY	OUTEN			INVERT			ENABLE
Access	R/W	R/W			R/W			R/W
Reset	0	0			0			0

**Bit 7 – RUNSTDBY** Run in Standby

Writing this bit to '1' will cause the ZCD to remain active when the device enters Standby sleep mode.

**Bit 6 – OUTEN** Output Pin Enable

Writing this bit to '1' connects the OUT signal to a supported pin.

**Bit 3 – INVERT** Invert Enable

Writing this bit to '1' inverts the ZCD output.

**Bit 0 – ENABLE** ZCD Enable

Writing this bit to '1' enables the ZCD.

**34.5.2 Interrupt Control**

**Name:** INTCTRL  
**Offset:** 0x02  
**Reset:** 0x00  
**Property:** -

Bit	7	6	5	4	3	2	1	0
							INTMODE[1:0]	
Access							R/W	R/W
Reset							0	0

**Bits 1:0 – INTMODE[1:0] Interrupt Mode**

Writing to these bits selects which edge(s) of the ZCD OUT signal will trigger the ZCD interrupt request.

Value	Name	Description
0x0	NONE	No interrupt
0x1	RISING	Interrupt on rising OUT signal
0x2	FALLING	Interrupt on falling OUT signal
0x3	BOTH	Interrupt on both rising and falling OUT signal

**34.5.3 Status**

**Name:** STATUS  
**Offset:** 0x03  
**Reset:** 0x00  
**Property:** -

Bit	7	6	5	4	3	2	1	0
				STATE				CROSSIF
Access				R				R/W
Reset				0				0

**Bit 4 – STATE** ZCD State

This bit indicates the current status of the OUT signal from the ZCD. This includes a three-cycle synchronizer delay.

**Bit 0 – CROSSIF** Cross Interrupt Flag

This is the zero-cross interrupt flag. Writing this bit to '1' will clear the interrupt flag. Writing this bit to '0' will have no effect.



## 35. UPDI - Unified Program and Debug Interface

### 35.1 Features

- UPDI One-Wire Interface for External Programming and On-Chip-Debugging (OCD)
  - Uses a dedicated pin of the device for programming
  - No GPIO pins occupied during the operation
  - Asynchronous half-duplex UART protocol towards the programmer
- Programming:
  - Built-in error detection and error signature generation
  - Override of response generation for faster programming
- Debugging:
  - Memory-mapped access to device address space (NVM, RAM, I/O)
  - No limitation on the device clock frequency
  - Unlimited number of user program breakpoints
  - Two hardware breakpoints
  - Support for advanced OCD features
    - Run-time readout of the CPU Program Counter (PC), Stack Pointer (SP) and Status Register (SREG) for code profiling
    - Detection and signalization of the Break/Stop condition in the CPU
    - Program flow control for Run, Stop and Reset debug instructions
  - Nonintrusive run-time chip monitoring without accessing the system registers
  - Interface for reading the result of the CRC check of the Flash on a locked device

### 35.2 Overview

The Unified Program and Debug Interface (UPDI) is a proprietary interface for external programming and OCD of a device.

The UPDI supports programming of Nonvolatile Memory (NVM) space, Flash, EEPROM, fuses, lock bits, and the user row. Some memory-mapped registers are accessible only with the correct access privilege enabled (key, lock bits) and only in the OCD Stopped mode or certain Programming modes. These modes are unlocked by sending the correct key to the UPDI. See the *NVMCTRL - Nonvolatile Memory Controller* section for programming via the NVM controller and executing NVM controller commands.

The UPDI is partitioned into three separate protocol layers: the UPDI Physical (PHY) Layer, the UPDI Data Link (DL) Layer and the UPDI Access (ACC) Layer. The default PHY layer handles bidirectional UART communication over the UPDI pin line towards a connected programmer/debugger and provides data recovery and clock recovery on an incoming data frame in the One-Wire Communication mode. Received instructions and corresponding data are handled by the DL layer, which sets up the communication with the ACC layer based on the decoded instruction. Access to the system bus and memory-mapped registers is granted through the ACC layer.

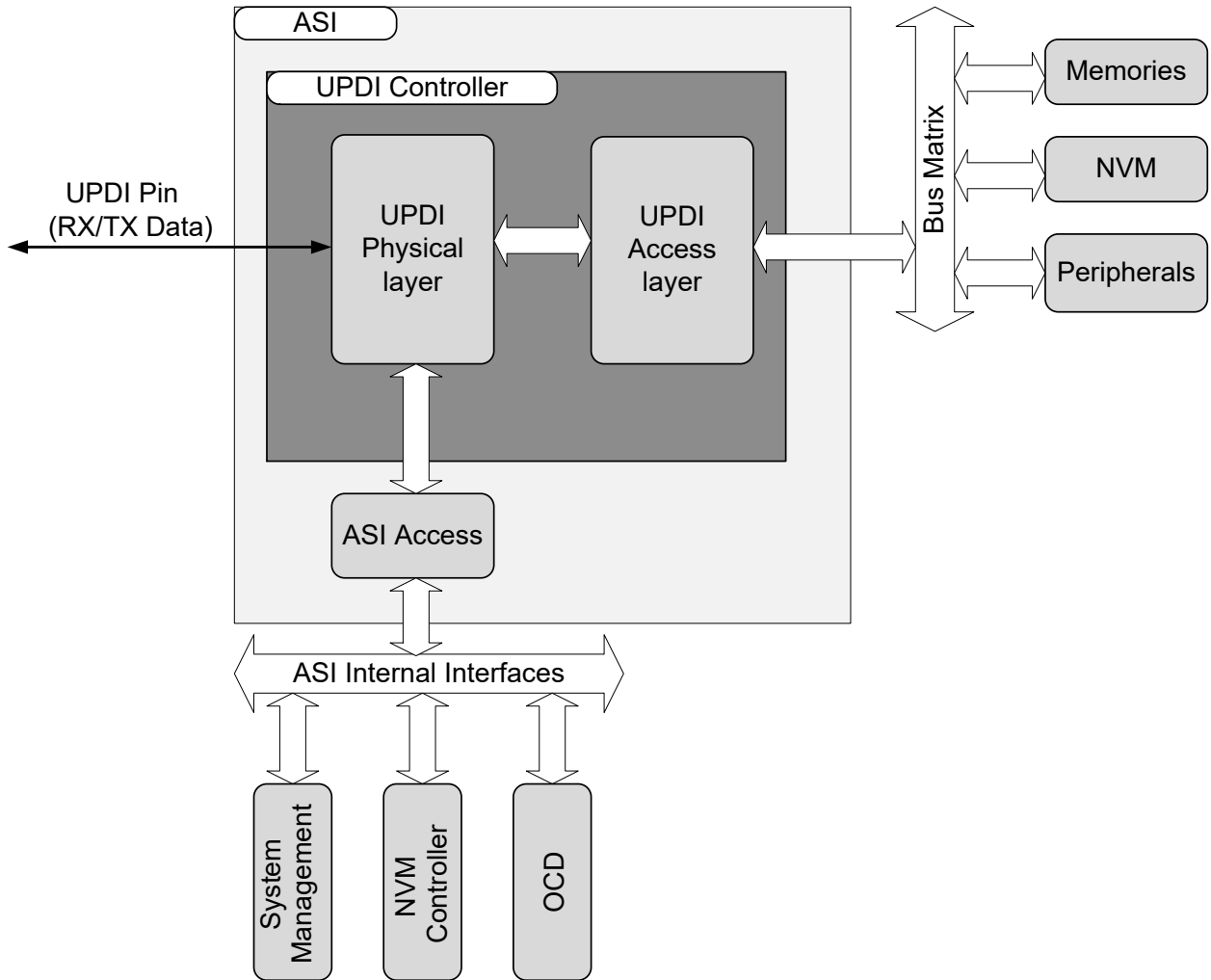
Programming and debugging are done through the PHY layer, which is a one-wire UART based on a half-duplex interface using a dedicated pin for data reception and transmission. The clocking of the PHY layer is done by a dedicated internal oscillator.

The ACC layer is the interface between the UPDI and the connected bus matrix. This layer grants access via the UPDI interface to the bus matrix with memory-mapped access to system blocks such as memories, NVM, and peripherals.

The Asynchronous System Interface (ASI) provides direct interface access to select features in the OCD, NVM, and System Management systems. This gives the debugger direct access to system information without requesting bus access.

35.2.1 Block Diagram

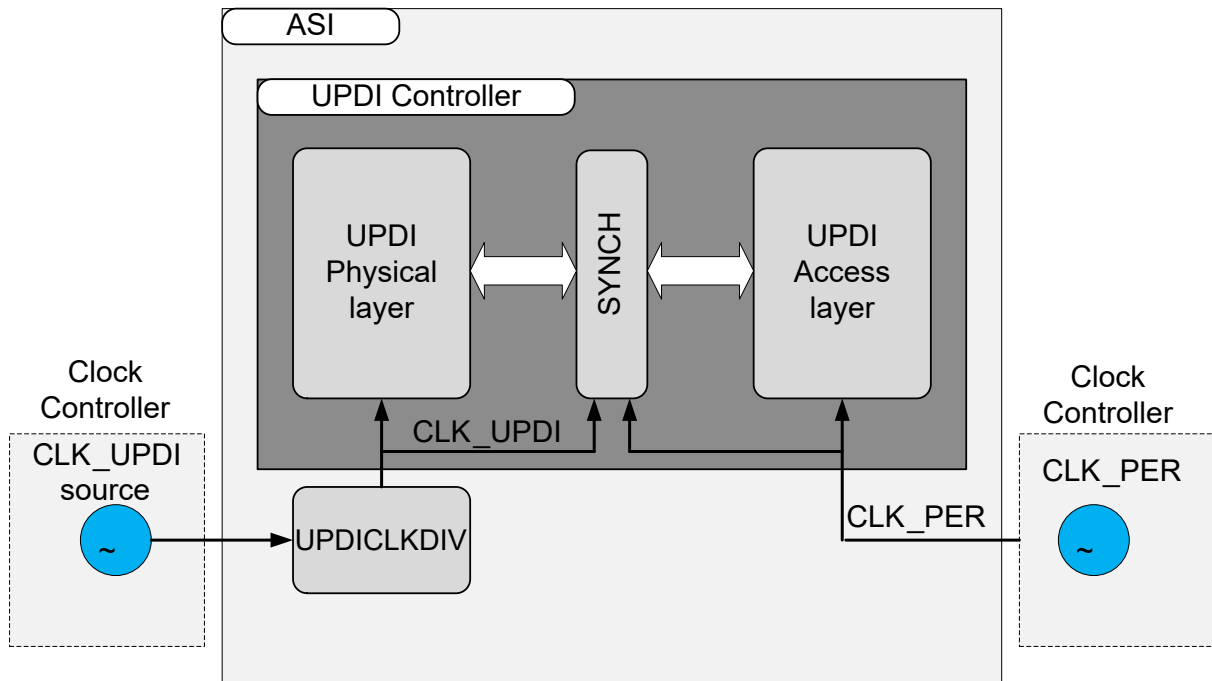
Figure 35-1. UPDI Block Diagram



35.2.2 Clocks

The PHY layer and the ACC layer can operate on different clock domains. The PHY layer clock is derived from the dedicated internal oscillator, and the ACC layer clock is the same as the peripheral clock. There is a synchronization boundary between the PHY and the ACC layer, which ensures correct operation between the clock domains. The UPDI clock output frequency is selected through the ASI, and the default UPDI clock start-up frequency is 4 MHz after enabling or resetting the UPDI. The UPDI clock frequency can be changed by writing to the UPDI Clock Divider Select (UPDICKDIV) bit field in the ASI Control A (UPDI.ASI\_CTRLA) register.

Figure 35-2. UPDI Clock Domains



### 35.2.3 Physical Layer

The PHY layer is the communication interface between a connected programmer/debugger and the device. The main features of the PHY layer can be summarized as follows:

- Dedicated pin on the device with no other function
- Support for UPDI One-Wire Asynchronous mode, using half-duplex UART communication on the UPDI pin
- Internal baud detection, clock and data recovery on the UART frame
- Error detection (parity, clock recovery, frame, system errors)
- Transmission response generation (ACK)
- Generation of error signatures during operation
- Guard time control

### 35.2.4 Pinout Description

The following table shows the functionality of the pin used by the UPDI. See the *I/O Multiplexing* section in the Device Data Sheet for more information about the UPDI physical pin.

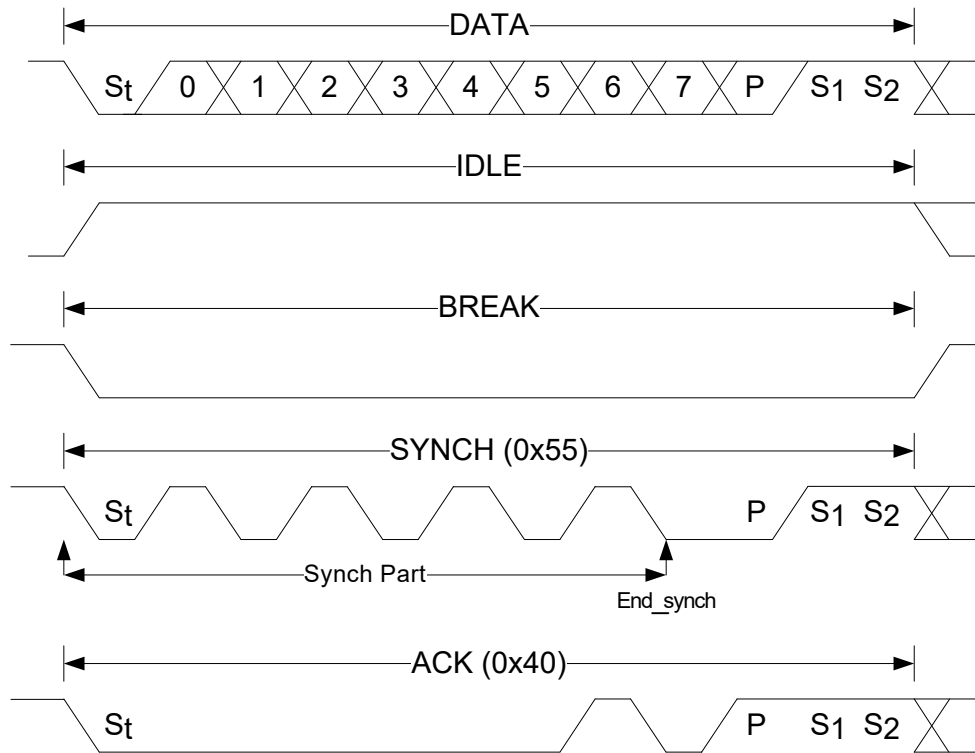
Function	Pin Name
UPDI	UPDI

## 35.3 Functional Description

### 35.3.1 Principle of Operation

The communication through the UPDI is based on standard UART communication, using a fixed frame format, and automatic baud rate detection for clock and data recovery. In addition to the data frame, several control frames are important to the communication: DATA, IDLE, BREAK, SYNCH, ACK.

**Figure 35-3. Supported UPDI Frame Formats**



Frame	Description
DATA	A DATA frame consists of one Start (St) bit which is always low, eight Data bits, one Parity (P) bit for even parity and two Stop (S1 and S2) bits which are always high. If the Parity bit or Stop bits have an incorrect value, an error will be detected and signaled by the UPDI. The parity bit-check in the UPDI can be disabled by writing to the Parity Disable (PARD) bit in the Control A (UPDI.CTRLA) register, in which case the parity generation from the debugger is ignored.
IDLE	This is a special frame that consists of 12 high bits. This is the same as keeping the transmission line in an Idle state.
BREAK	This is a special frame that consists of 12 low bits. It is used to reset the UPDI back to its default state and is typically used for error recovery.
SYNCH	The SYNCH frame is used by the Baud Rate Generator to set the baud rate for the coming transmission. A SYNCH character is always expected by the UPDI in front of every new instruction, and after a successful BREAK has been transmitted.
ACK	The ACK frame is transmitted from the UPDI whenever an ST or an STS instruction has successfully crossed the synchronization boundary and gained bus access. When an ACK is received by the debugger, the next transmission can start.

### 35.3.1.1 UPDI UART

The communication is initiated from the master debugger/programmer side, and every transmission must start with a SYNCH character, which the UPDI can use to recover the transmission baud rate and store this setting for the incoming data. The baud rate set by the SYNCH character will be used for both reception and transmission of the subsequent instruction and data bytes. See the [35.3.3 UPDI Instruction Set](#) section for details on when the next SYNCH character is expected in the instruction stream.

There is no writable Baud Rate register in the UPDI, so the baud rate sampled from the SYNCH character is used for data recovery when sampling the data byte.

The transmission baud rate of the PHY layer is related to the selected UPDI clock, which can be adjusted by writing to the UPDI Clock Divider Select (UPDICKDIV) bit field in the ASI Control A (UPDI.ASI\_CTRLA) register. The receive and transmit baud rates are always the same within the accuracy of the auto-baud.

**Table 35-1. Recommended UART Baud Rate Based on UPDICKDIV Setting**

UPDICKDIV[1:0]	Max. Recommended Baud Rate	Min. Recommended Baud Rate
0x0 (32 MHz)	1.6 Mbps	0.600 kbps
0x1 (16 MHz)	0.9 Mbps	0.300 kbps
0x2 (8 MHz)	450 kbps	0.150 kbps
0x3 (4 MHz) - Default	225 kbps	0.075 kbps

The UPDI Baud Rate Generator utilizes fractional baud counting to minimize the transmission error. With the fixed frame format used by the UPDI, the maximum and recommended receiver transmission error limits can be seen in the following table:

**Table 35-2. Receiver Baud Rate Error**

Data + Parity Bits	R <sub>slow</sub>	R <sub>fast</sub>	Max. Total Error [%]	Recommended Max. RX Error [%]
9	96.39	104.76	+4.76/-3.61	+1.5/-1.5

### 35.3.1.2 BREAK Character

The BREAK character is used to reset the internal state of the UPDI to the default setting. This is useful if the UPDI enters an Error state due to a communication error or when the synchronization between the debugger and the UPDI is lost.

To ensure that a BREAK is successfully received by the UPDI in all cases, the debugger must send two consecutive BREAK characters. The first BREAK will be detected if the UPDI is in Idle state and will not be detected if it is sent while the UPDI is receiving or transmitting (at a very low baud rate). However, this will cause a frame error for the reception (RX) or a contention error for the transmission (TX), and abort the ongoing operation. The UPDI will then detect the next BREAK successfully.

Upon receiving a BREAK, the UPDI oscillator setting in the ASI Control A (UPDI.ASI\_CTRLA) register is reset to the 4 MHz default UPDI clock selection. This changes the baud rate range of the UPDI, according to [Table 35-1](#).

### 35.3.1.2.1 BREAK in One-Wire Mode

In One-Wire mode, the programmer/debugger and UPDI can be totally out of synch, requiring a worst-case length for the BREAK character to be sure that the UPDI can detect it. Assuming the slowest UPDI clock speed of 4 MHz (250 ns), the maximum length of the 8-bit SYNCH pattern value that can be contained in 16 bits is  $65535 \times 250 \text{ ns} = 16.4 \text{ ms/byte} = 16.4 \text{ ms}/8 \text{ bits} = 2.05 \text{ ms/bit}$ .

This gives a worst-case BREAK frame duration of  $2.05 \text{ ms} \times 12 \text{ bits} \approx 24.6 \text{ ms}$  for the slowest prescaler setting. When the prescaler setting is known, the time of the BREAK frame can be relaxed according to the values from the next table:

**Table 35-3. Recommended BREAK Character Duration**

UPDICKDIV[1:0]	Recommended BREAK Character Duration
0x0 (32 MHz)	3.075 ms
0x1 (16 MHz)	6.15 ms
0x2 (8 MHz)	12.30 ms
0x3 (4 MHz)	24.60 ms

### 35.3.1.3 SYNCH Character

The SYNCH character has eight bits and follows the regular UPDI frame format. It has a fixed data bit value of '0x55'. The SYNCH character has two main purposes:

1. It acts as the enabling character for the UPDI after a disable.
2. It is used by the Baud Rate Generator to set the baud rate for the subsequent transmission. If an invalid SYNCH character is sent, the next transmission will not be sampled correctly.

#### 35.3.1.3.1 SYNCH in One-Wire Mode

The SYNCH character is used before each new instruction. When using the `REPEAT` instruction, the SYNCH character is expected only before the first instruction after `REPEAT`.

The SYNCH is a known character which, through its property of toggling for each bit, allows the UPDI to measure how many UPDI clock cycles are needed to sample the 8-bit SYNCH pattern. The information obtained through the sampling is used to provide Asynchronous Clock Recovery and Asynchronous Data Recovery on reception, and to keep the baud rate of the connected programmer when doing transmit operations.

### 35.3.2 Operation

The UPDI must be enabled before the UART communication can start.

#### 35.3.2.1 UPDI Enabling

The devices have a dedicated UPDI pin with no other function. The enable sequence for the UPDI is device independent and is described in the following paragraphs.

##### 35.3.2.1.1 One-Wire Enable

The UPDI pin has a constant pull-up enable, and by driving the UPDI pin low for more than 200 ns, a connected programmer will initiate the start-up sequence.

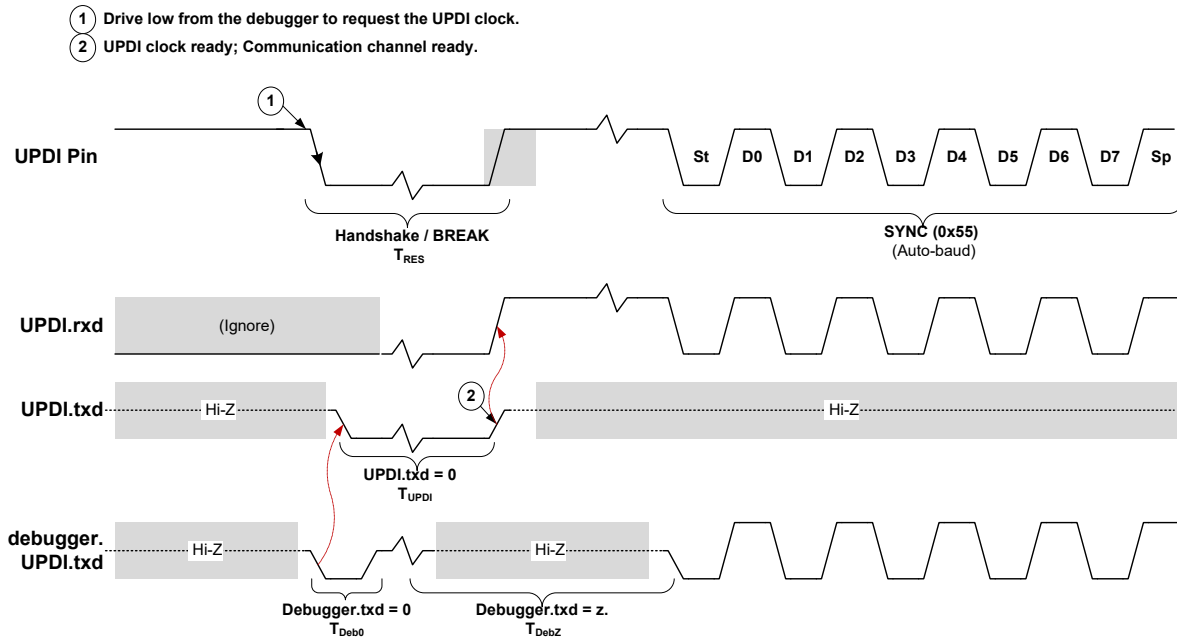
The negative edge transition will cause an edge detector (located in the high-voltage domain if it is in a Multi-Voltage System) to start driving the UPDI pin low, so when the programmer releases the line, it will stay low until the requested UPDI oscillator is ready. The expected arrival time for the clock will depend on the oscillator implementation regarding the accuracy, overshoot and readout of the oscillator calibration. For a Multi-Voltage System, the line will be driven low until the regulator is at the correct level, and the system is powered up with the selected oscillator ready and stable. The programmer must poll the UPDI pin after releasing it the first time to detect when the pin transitions to high again. This transition means that the edge detector has released the pin (pull-up), and the UPDI can receive a SYNCH character. Upon successful detection of the SYNCH character, the UPDI is enabled and will prepare for the reception of the first instruction.

The enable transmission sequence is shown in the next figure, where the active driving periods for the programmer and edge detector are included. The “UPDI pin” waveform shows the pin value at any given time.

The delay given for the edge detector active drive period is a typical start-up time waiting for 256 cycles on a 32 MHz oscillator + the calibration readout. Refer to the *Electrical Characteristics* section for details on the expected start-up times.

**Note:** The first instruction issued after the initial enable SYNCH does not need an extra SYNCH to be sent because the enable sequence SYNCH sets up the Baud Rate Generator for the first instruction.

**Figure 35-4. UPDI Enable Sequence**



To avoid the UPDI from staying enabled if an accidental trigger of the edge detector happens, the UPDI will automatically disable itself and lower its clock request. See the *Disable During Start-up* section for more details.

### 35.3.2.2 UPDI Disabling

#### 35.3.2.2.1 Disable During Start-up

During the enable sequence, the UPDI can disable itself in case of an invalid enable sequence. There are two mechanisms implemented to reset any requests the UPDI has given to the Power Management and set the UPDI to the disabled state. A new enable sequence must then be initiated to enable the UPDI.

##### **Time-Out Disable**

When the start-up negative edge detector releases the pin after the UPDI has received its clock, or when the regulator is stable and the system has power in a Multi-Voltage system, the default pull-up drives the UPDI pin high. If the programmer does not detect that the pin is high, and does not initiate a transmission of the SYNCH character within 16.4 ms at 4 MHz UPDI clock after the UPDI has released the pin, the UPDI will disable itself.

**Note:** Start-up oscillator frequency is device-dependent. The UPDI will count for 65536 cycles on the UPDI clock before issuing the time-out.

##### **Incorrect SYNCH pattern**

An incorrect SYNCH pattern is detected if the length of the SYNCH character is longer than the number of samples that can be contained in the UPDI Baud Rate register (overflow), or shorter than the minimum fractional count that can be handled for the sampling length of each bit. If any of these errors are detected, the UPDI will disable itself.

#### 35.3.2.2.2 UPDI Regular Disable

Any programming or debugging session that does not require any specific operation from the UPDI after disconnecting the programmer has to be terminated by writing the UPDI Disable (UPDIDIS) bit in the Control B (UPDI.CTRLB) register, upon which the UPDI will issue a System Reset and disable itself. The Reset will restore the CPU to the Run state, independent of the previous state. It will also lower the UPDI clock request to the system, and reset any UPDI KEYS and settings.

If the disable operation is not performed, the UPDI and the oscillator's request will remain enabled. This causes increased power consumption for the application.

### 35.3.2.3 UPDI Communication Error Handling

The UPDI contains a comprehensive error detection system that provides information to the debugger when recovering from an error scenario. The error detection consists of detecting physical transmission errors like parity error, contention error, and frame error, to more high-level errors like access time-out error. See the UPDI Error Signature (PESIG) bit field in the Status B (UPDI.STATUSB) register for an overview of the available error signatures.

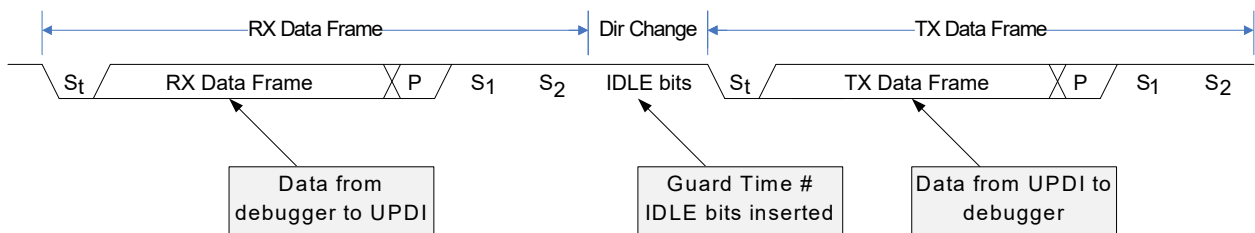
Whenever the UPDI detects an error, it will immediately enter an internal Error state to avoid unwanted system communication. In the Error state, the UPDI will ignore all incoming data requests, except when a BREAK character is received. The following procedure must always be applied when recovering from an Error condition.

1. Send a BREAK character. See the [35.3.1.2 BREAK Character](#) section for recommended BREAK character handling.
2. Send a SYNCH character at the desired baud rate for the next data transfer.
3. Execute a Load Control Status (LD<sub>CS</sub>) instruction to read the UPDI Error Signature (PESIG) bit field in the Status B (UPDI.STATUSB) register and get the information about the occurred error.
4. The UPDI has now recovered from the Error state and is ready to receive the next SYNCH character and instruction.

### 35.3.2.4 Direction Change

To ensure correct timing for a half-duplex UART operation, the UPDI has a built-in guard time mechanism to relax the timing when changing direction from RX to TX mode. The guard time is represented by Idle bits inserted before the next Start bit of the first response byte is transmitted. The number of Idle bits can be configured through the Guard Time Value (GTVAL) bit field in the Control A (UPDI.CTRLA) register. The duration of each Idle bit is given by the baud rate used by the current transmission.

**Figure 35-5. UPDI Direction Change by Inserting Idle Bits**



The UPDI guard time is the minimum Idle time that the connected debugger will experience when waiting for data from the UPDI. The maximum Idle time is the same as time-out. The Idle time before a transmission will be more than the expected guard time when the synchronization time plus the data bus accessing time is longer than the guard time.

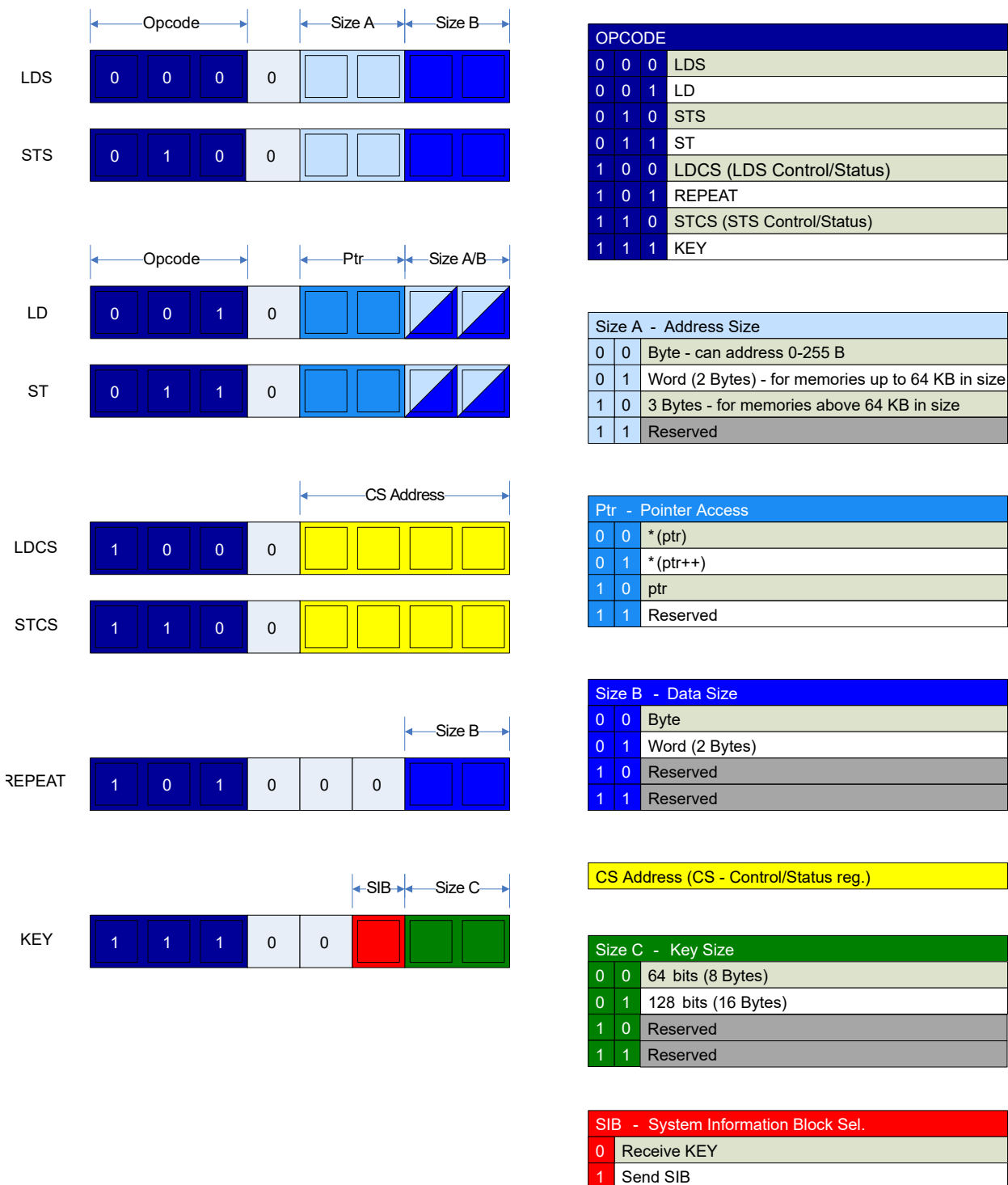
It is recommended to always use the insertion of minimum two Guard Time bits on the UPDI side, and one guard time cycle insertion from the debugger side.

### 35.3.3 UPDI Instruction Set

The communication through the UPDI is based on a small instruction set. These instructions are part of the UPDI Data Link (DL) layer. The instructions are used to access the UPDI registers, since they are mapped into an internal memory space called "ASI Control and Status (CS) space", as well as the memory-mapped system space. All instructions are byte instructions and must be preceded by a SYNCH character to determine the baud rate for the communication. See [35.3.1.1 UPDI UART](#) for information about setting the baud rate for the transmission. The following figure gives an overview of the UPDI instruction set.



**Figure 35-6. UPDI Instruction Set Overview**



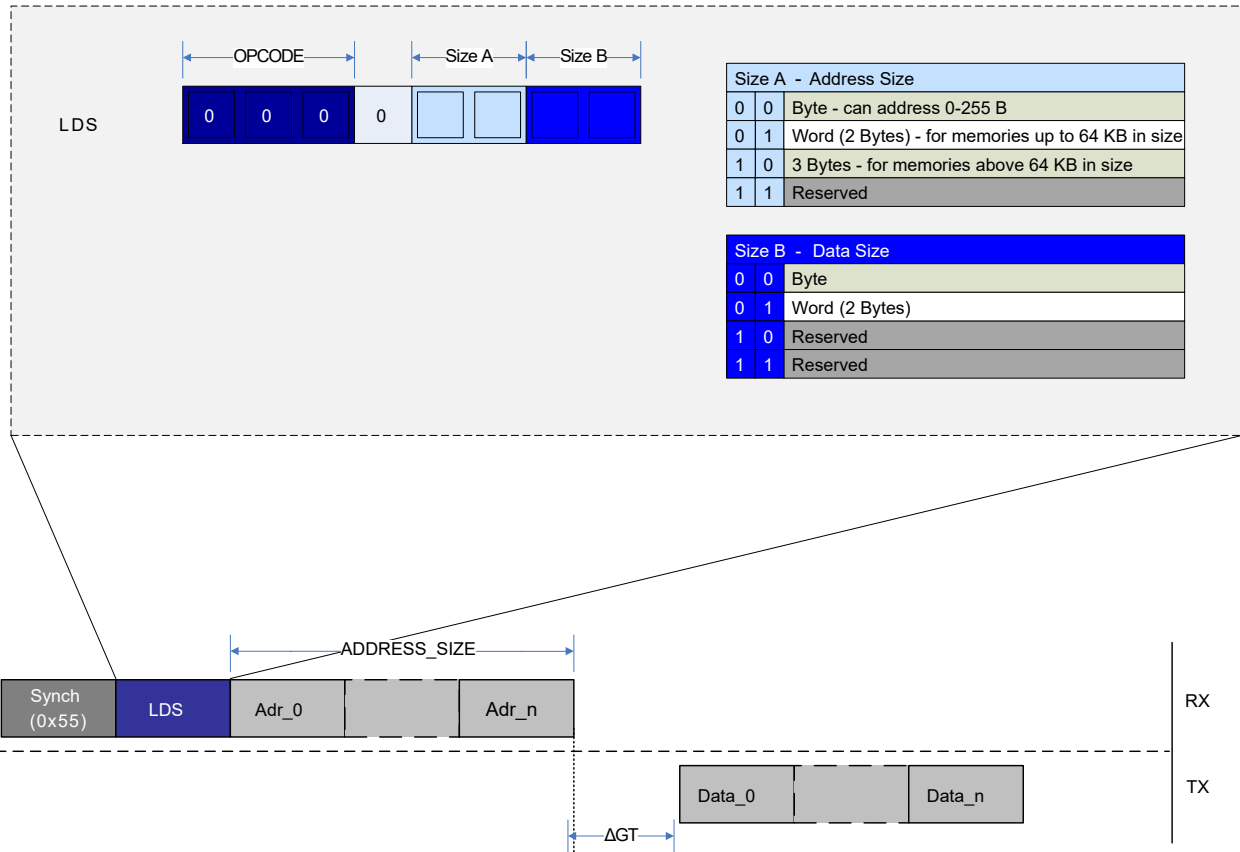
### 35.3.3.1 LDS - Load Data from Data Space Using Direct Addressing

The `LDS` instruction is used to load data from the system bus into the PHY layer shift register for serial readout. The `LDS` instruction is based on direct addressing, and the address must be given as an operand to the instruction for the

data transfer to start. The maximum supported size for the address and data is 32 bits. The `LDS` instruction supports repeated memory access when combined with the `REPEAT` instruction.

After issuing the `LDS` instruction, the number of desired address bytes, as indicated by the Size A field followed by the output data size, which is selected by the Size B field, must be transmitted. The output data is issued after the specified Guard Time (GT). When combined with the `REPEAT` instruction, the address must be sent in for each iteration of the repeat, meaning after each time the output data sampling is done. There is no automatic address increment when using `REPEAT` with `LDS`, as it uses a direct addressing protocol.

**Figure 35-7. LDS Instruction Operation**



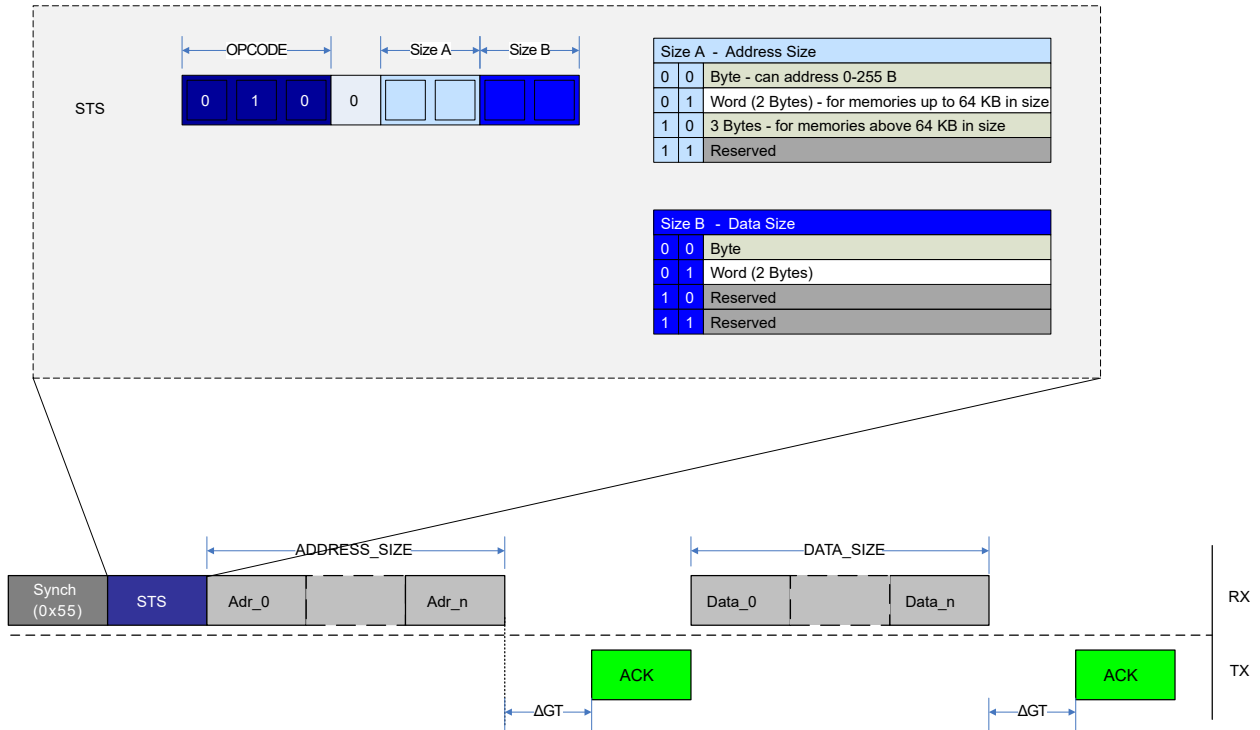
When the instruction is decoded, and the address byte(s) are received as dictated by the decoded instruction, the DL layer will synchronize all required information to the ACC layer, which will handle the bus request and synchronize data buffered from the bus back again to the DL layer. This will create a synchronization delay that must be taken into consideration upon receiving the data from the UPDI.

### 35.3.3.2 STS - Store Data to Data Space Using Direct Addressing

The `STS` instruction is used to store data that are shifted serially into the PHY layer shift register to the system bus address space. The `STS` instruction is based on direct addressing, and the address must be given as an operand to the instruction for the data transfer to start. The address is the first set of operands, and data are the second set. The size of the address and data operands are given by the size fields presented in the figure below. The maximum size for both address and data is 32 bits.

The `STS` supports repeated memory access when combined with the `REPEAT` instruction.

**Figure 35-8. STS Instruction Operation**



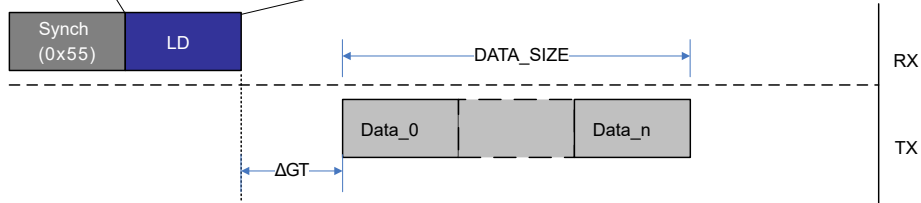
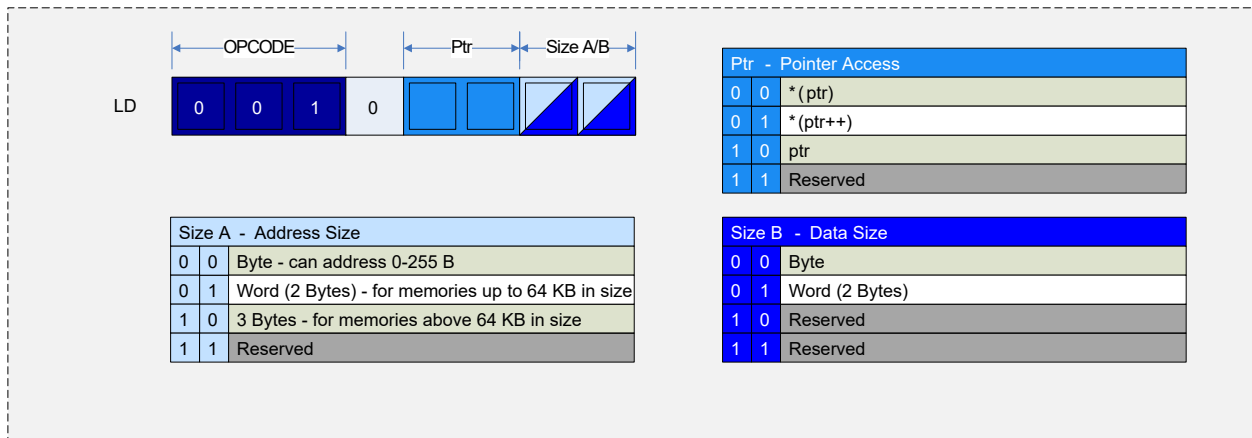
The transfer protocol for an *STS* instruction is depicted in the above figure, following this sequence:

1. The address is sent.
2. An Acknowledge (ACK) is sent back from the UPDI if the transfer was successful.
3. The number of bytes, as specified in the *STS* instruction, is sent.
4. A new ACK is received after the data have been successfully transferred.

### 35.3.3.3 LD - Load Data from Data Space Using Indirect Addressing

The *LD* instruction is used to load data from the data space and into the PHY layer shift register for serial readout. The *LD* instruction is based on indirect addressing, which means that the Address Pointer in the UPDI needs to be written before the data space read access. Automatic pointer post-increment operation is supported and is useful when the *LD* instruction is utilized with the *REPEAT* instruction. It is also possible to do an *LD* from the UPDI Pointer register. The maximum supported size for address and data load is 32 bits.

Figure 35-9. LD Instruction Operation



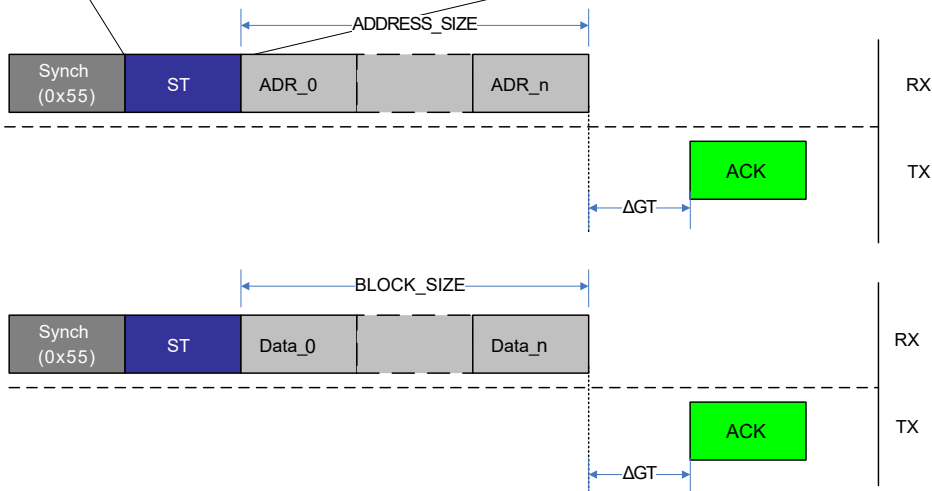
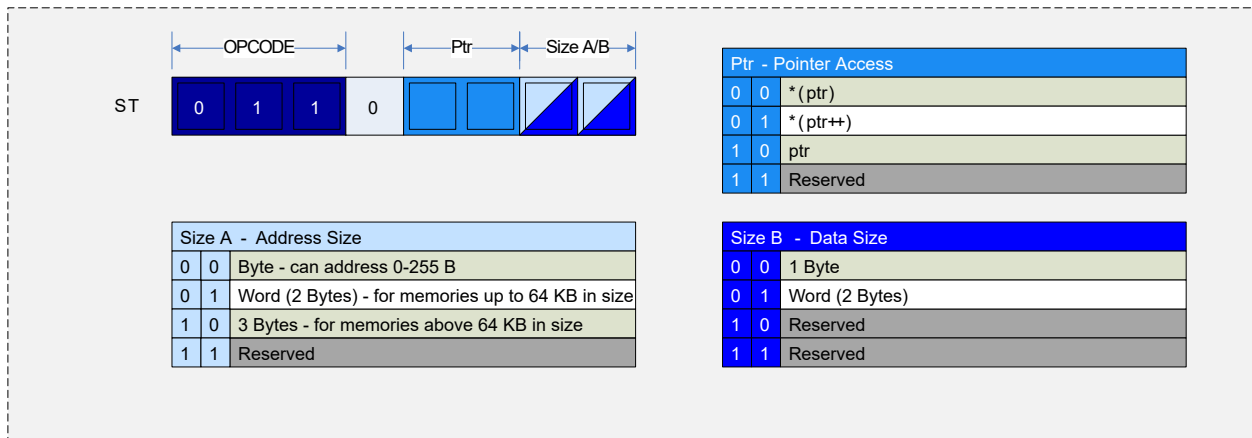
The figure above shows an example of a typical LD sequence, where the data are received after the Guard Time (GT) period. Loading data from the UPDI Pointer register follows the same transmission protocol.

For the LD instruction from the data space, the pointer register must be set up by using an ST instruction to the UPDI Pointer register. After the ACK has been received on a successful Pointer register write, the LD instruction must be set up with the desired DATA SIZE operands. An LD to the UPDI Pointer register is done directly with the LD instruction.

### 35.3.3.4 ST - Store Data from UPDI to Data Space Using Indirect Addressing

The ST instruction is used to store data from the UPDI PHY shift register to the data space. The ST instruction is used to store data that are shifted serially into the PHY layer. The ST instruction is based on indirect addressing, which means that the Address Pointer in the UPDI needs to be written before the data space. The automatic pointer post-increment operation is supported and is useful when the ST instruction is utilized with the REPEAT instruction. The ST instruction is also used to store the UPDI Address Pointer into the Pointer register. The maximum supported size for storing address and data is 32 bits.

**Figure 35-10. ST Instruction Operation**



The figure above gives an example of an *ST* instruction to the UPDI Pointer register and the storage of regular data. A SYNCH character is sent before each instruction. In both cases, an Acknowledge (ACK) is sent back by the UPDI if the *ST* instruction was successful.

To write the UPDI Pointer register, the following procedure has to be followed:

1. Set the PTR field in the *ST* instruction to signature 0x2.
2. Set the address size (Size A) field to the desired address size.
3. After issuing the *ST* instruction, send Size A bytes of address data.
4. Wait for the ACK character, which signifies a successful write to the Address register.

After the Address register is written, sending data is done in a similarly:

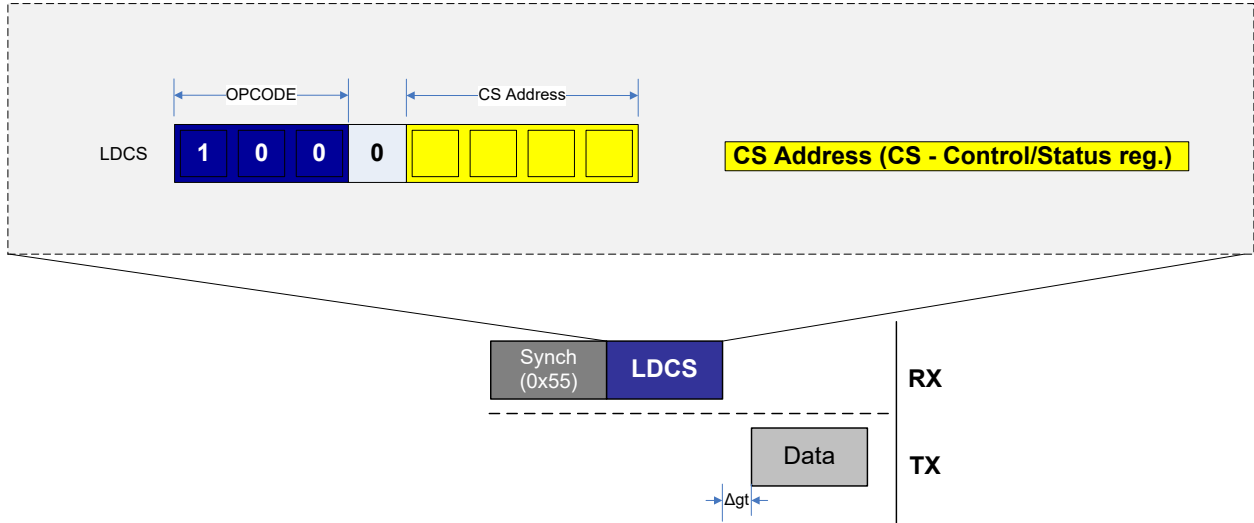
1. Set the PTR field in the *ST* instruction to signature 0x0 to write to the address specified by the UPDI Pointer register. If the PTR field is set to 0x1, the UPDI pointer is automatically updated to the next address according to the data size Size B field of the instruction after the write is executed.
2. Set the Size B field in the instruction to the desired data size.
3. After sending the *ST* instruction, send Size B bytes of data.
4. Wait for the ACK character, which signifies a successful write to the bus matrix.

When used with the REPEAT instruction, it is recommended to set up the Address register with the start address for the block to be written and use the Pointer Post Increment register to automatically increase the address for each repeat cycle. When using the REPEAT instruction, the data frame of Size B data bytes can be sent after each received ACK.

**35.3.3.5 LDCS - Load Data from Control and Status Register Space**

The LDCS instruction is used to load serial readout data from the UPDI Control and the Status register space located in the DL layer into the PHY layer shift register. The LDCS instruction is based on direct addressing, where the address is part of the instruction operands. The LDCS instruction can access only the UPDI CS register space. This instruction supports only byte access, and the data size is not configurable.

**Figure 35-11. LDCS Instruction Operation**

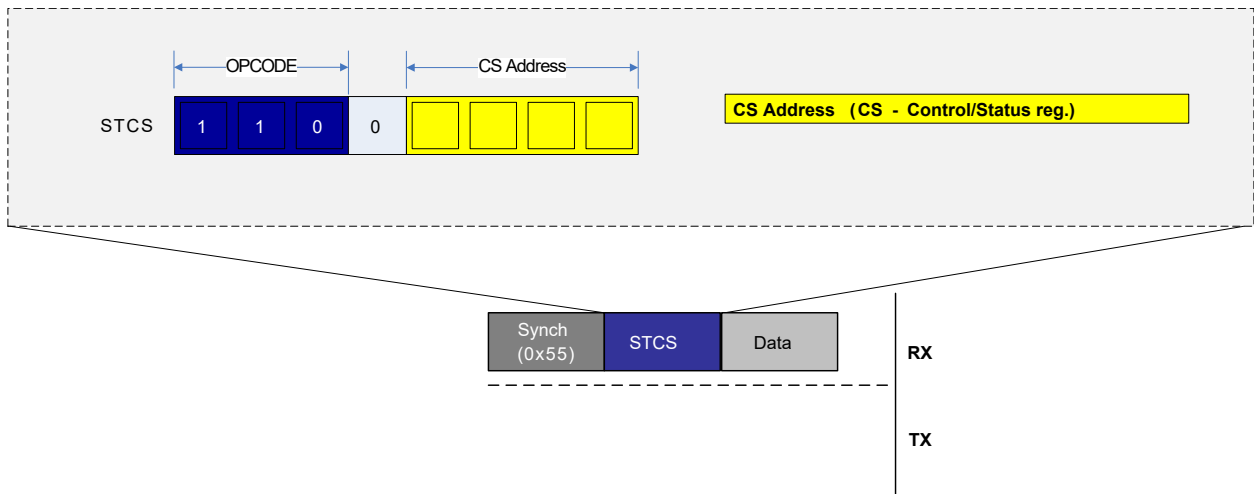


The figure above shows a typical example of LDCS data transmission. A data byte from the LDCS is transmitted from the UPDI after the guard time is completed.

**35.3.3.6 STCS (Store Data to Control and Status Register Space)**

The STCS instruction is used to store data to the UPDI Control and Status register space. Data are shifted in serially into the PHY layer shift register and written as a whole byte to a selected CS register. The STCS instruction is based on direct addressing, where the address is part of the instruction operand. The STCS instruction can access only the internal UPDI register space. This instruction supports only byte access, and the data size is not configurable.

**Figure 35-12. STCS Instruction Operation**



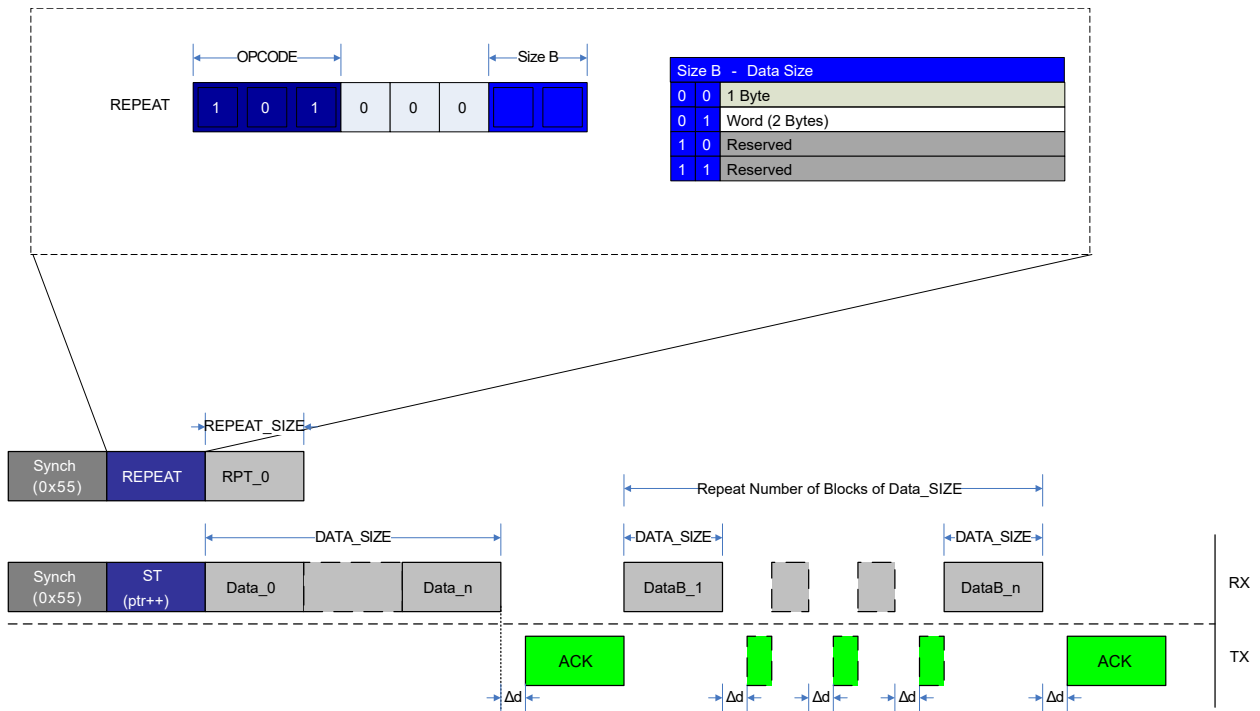
The figure above shows the data frame transmitted after the SYNCH character and the instruction frames. The STCS instruction byte can be immediately followed by the data byte. There is no response generated from the STCS instruction, as is the case for the ST and STS instructions.

**35.3.3.7 REPEAT - Set Instruction Repeat Counter**

The REPEAT instruction is used to store the repeat count value into the UPDI Repeat Counter register on the DL layer. When instructions are used with REPEAT, the protocol overhead for SYNCH and instruction frame can be omitted on all instructions except the first instruction after the REPEAT is issued. REPEAT is most useful for memory instructions (LD, ST, LDS, STS), but all instructions can be repeated, except for the REPEAT instruction itself.

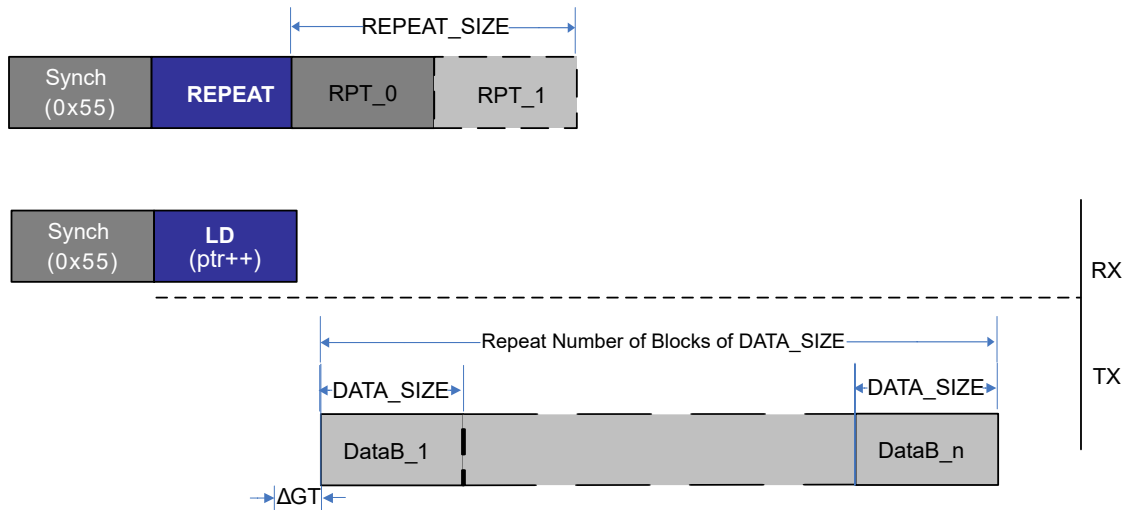
The DATA\_SIZE operand field refers to the size of the repeat value. Only up to 255 repeats are supported. The instruction loaded directly after the REPEAT instruction will be issued for  $RPT\_0 + 1$  times. If the Repeat Counter register is '0', the instruction will run just once. An ongoing repeat can be aborted only by sending a BREAK character.

**Figure 35-13. REPEAT Instruction Operation used with ST Instruction**



The figure above gives an example of repeat operation with an ST instruction using pointer post-increment operation. After the REPEAT instruction is sent with  $RPT\_0 = n$ , the first ST instruction is issued with SYNCH and instruction frame, while the next  $n$  ST instructions are executed by only sending data bytes according to the ST operand DATA\_SIZE, and maintaining the Acknowledge (ACK) handshake protocol.

Figure 35-14. REPEAT used with LD Instruction



For LD, data will come out continuously after the LD instruction. Note the guard time on the first data block.

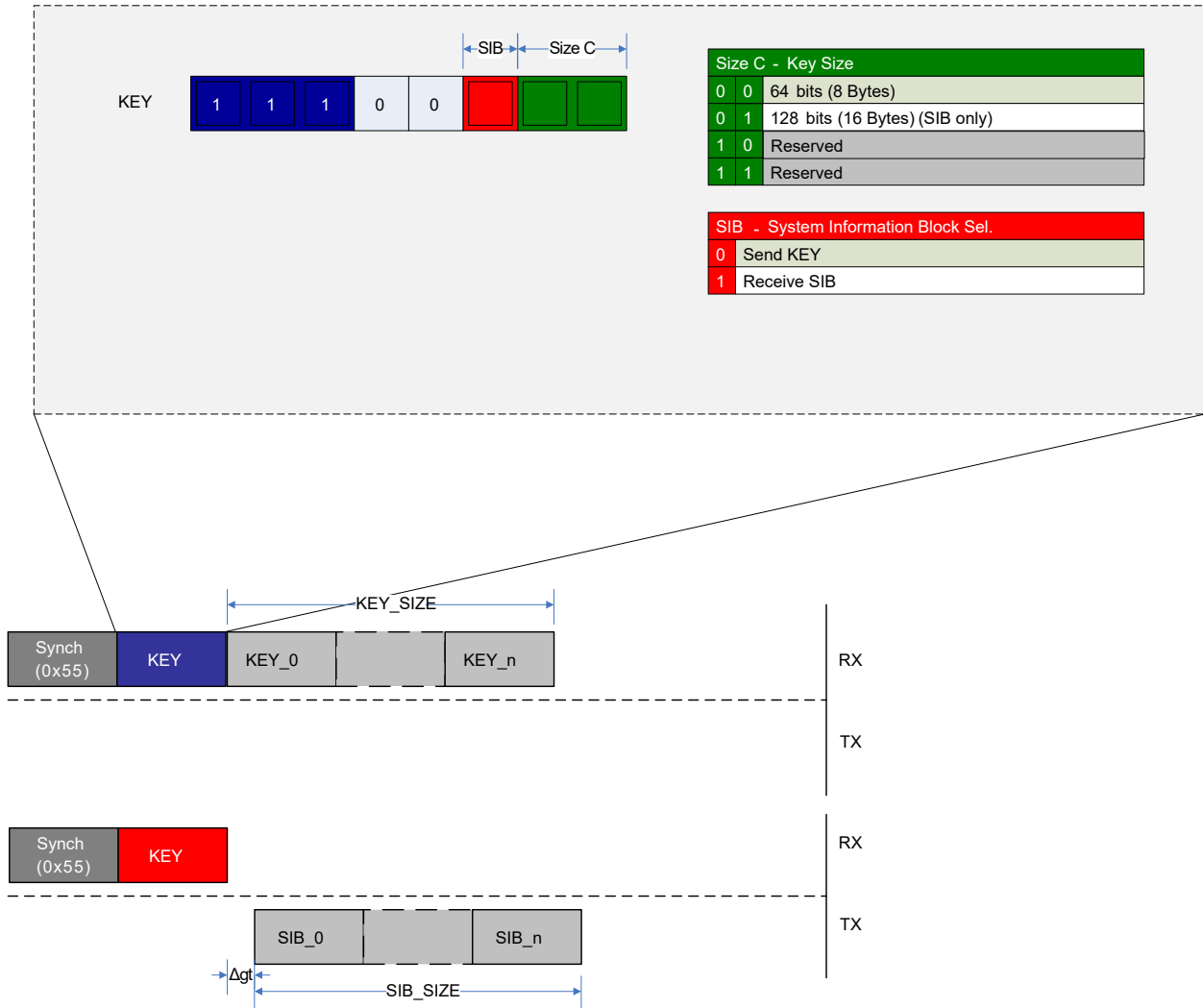
If using indirect addressing instructions (LD/ST), it is recommended to always use the pointer post-increment option when combined with REPEAT. The ST/LD instruction is necessary only before the first data block (number of data bytes determined by DATA\_SIZE). Otherwise, the same address will be accessed in all repeated access operations. For direct addressing instructions (LDS/STS), the address must always be transmitted as specified in the instruction protocol, before data can be received (LDS) or sent (STS).

### 35.3.3.8 KEY - Set Activation Key or Send System Information Block

The KEY instruction is used for communicating key bytes to the UPDI or for providing the programmer with a System Information Block (SIB), opening up for executing protected features on the device. See Table 35-4 for an overview of functions that are activated by keys. For the KEY instruction, only a 64-bit key size is supported. The maximum supported size for SIB is 128 bits.



**Figure 35-15. KEY Instruction Operation**



The figure above shows the transmission of a key and the reception of a SIB. In both cases, the Size C (*SIZE\_C*) field in the operand determines the number of frames being sent or received. There is no response after sending a *KEY* to the UPDI. When requesting the SIB, data will be transmitted from the UPDI according to the current guard time setting.

### 35.3.4 CRC Checking of Flash During Boot

Some devices support running a CRC check of the Flash contents as part of the boot process. This check can be performed even when the device is locked. The result of this CRC check can be read from the *ASI\_CRC\_STATUS* register. Refer to the *CRCSCAN* section in the device data sheet for more information on this feature.

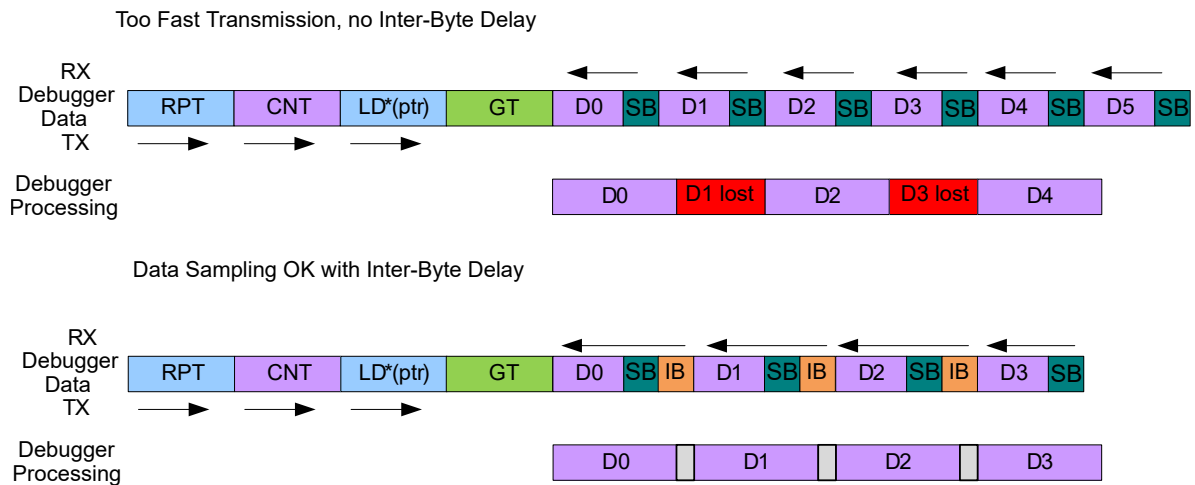
### 35.3.5 Inter-Byte Delay

When performing a multi-byte transfer (*LD* combined with *REPEAT*), or reading out the System Information Block (SIB), the output data will come out in a continuous stream. Depending on the application, on the receiver side, the data might come out too fast, and there might not be enough time for the data to be processed before the next Start bit arrives.

The inter-byte delay works by inserting a fixed number of Idle bits for multi-byte transfers. The reason for adding an inter-byte delay is that there is no guard time inserted when all data is going in the same direction.

The inter-byte delay feature can be enabled by writing a '1' to the Inter-Byte Delay Enable (IBDLY) bit in the Control A (UPDI.CTRLA) register. As a result, two extra Idle bits will be inserted between each byte to relax the sampling time for the debugger.

**Figure 35-16. Inter-Byte Delay Example with LD and RPT**



**Notes:**

1. GT denotes the guard time insertion.
2. SB is for Stop bit.
3. IB is the inserted inter-byte delay.
4. The rest of the frames are data and instructions.

**35.3.6 System Information Block**

The System Information Block (SIB) can be read out at any time by setting the SIB bit according to the `KEY` instruction from [35.3.3.8 KEY - Set Activation Key or Send System Information Block](#). The SIB is always accessible to the debugger, regardless of lock bit settings, and provides a compact form of supplying information about the device and system parameters for the debugger. The information is vital in identifying and setting up the proper communication channel with the device. The output of the SIB is interpreted as ASCII symbols. The key size field must be set to 16 bytes when reading out the complete SIB, and an 8-byte size can be used to read out only the Family\_ID. See the figure below for SIB format description and which data are available at different readout sizes.

**Figure 35-17. System Information Block Format**

16	8	[Byte][Bits]	Field Name
16	8	[6:0] [55:0]	Family_ID
		[7][7:0]	Reserved
	[10:8][23:0]	NVM_VERSION	
	[13:11][23:0]	OCD_VERSION	
	[14][7:0]	RESERVED	
	[15][7:0]	DBG_OSC_FREQ	

**35.3.7 Enabling of Key Protected Interfaces**

The access to some internal interfaces and features is protected by the UPDI key mechanism. To activate a key, the correct key data must be transmitted by using the `KEY` instruction, as described in [35.3.3.8 KEY - Set Activation Key or Send System Information Block](#). The table below describes the available keys and the condition required when doing the operation with the key active.

**Table 35-4. Key Activation Overview**

Key Name	Description	Requirements for Operation	Conditions for Key Invalidation
Chip Erase	Start NVM chip erase. Clear lock bits	-	UPDI Disable/UPDI Reset

.....continued

Key Name	Description	Requirements for Operation	Conditions for Key Invalidation
NVMPROG	Activate NVM Programming	Lock bits cleared. ASI_SYS_STATUS.NVMPROG set	Programming done/UPDI Reset
USERROW-Write	Program the user row on the locked device	Lock bits set. ASI_SYS_STATUS.UROWPROG set	Write to key Status bit/ UPDI Reset

The table below gives an overview of the available key signatures that must be shifted in to activate the interfaces.

**Table 35-5. Key Activation Signatures**

Key Name	Key Signature (LSB Written First)	Size
Chip Erase	0x4E564D4572617365	64 bits
NVMPROG	0x4E564D50726F6720	64 bits
USERROW-Write	0x4E564D5573267465	64 bits

### 35.3.7.1 Chip Erase

The following steps must be followed to issue a chip erase:

1. Enter the Chip Erase key by using the `KEY` instruction. See [Table 35-5](#) for the CHIPERASE signature.
2. **Optional:** Read the Chip Erase (CHIPERASE) bit in the ASI Key Status (UPDI.ASI\_KEY\_STATUS) register to see that the key is successfully activated.
3. Write the signature to the Reset Request (RSTREQ) bit in the ASI Reset Request (UPDI.ASI\_RESET\_REQ) register. This will issue a System Reset.
4. Write `0x00` to the ASI Reset Request (UPDI.ASI\_RESET\_REQ) register to clear the System Reset.
5. Read the NVM Lock Status (LOCKSTATUS) bit from the ASI System Status (UPDI.ASI\_SYS\_STATUS) register.
6. The chip erase is done when LOCKSTATUS bit is '0'. If the LOCKSTATUS bit is '1', return to step 5.
7. Check the Chip Erase Key Failed (ERASE\_FAILED) bit in the ASI System Status (UPDI.ASI\_SYS\_STATUS) register to verify if the chip erase was successful.
8. If the ERASE\_FAILED bit is '0', the chip erase was successful.

After a successful chip erase, the lock bits will be cleared, and the UPDI will have full access to the system. Until the lock bits are cleared, the UPDI cannot access the system bus, and only CS-space operations can be performed.



During chip erase, the BOD is forced in ON state by writing to the Active (ACTIVE) bit field from the Control A (BOD.CTRLA) register and uses the BOD Level (LVL) bit field from the BOD Configuration (FUSE.BODCFG) fuse and the BOD Level (LVL) bit field from the Control B (BOD.CTRLB) register. If the supply voltage  $V_{DD}$  is below that threshold level, the device is unavailable until  $V_{DD}$  is increased adequately. See the *BOD* section for more details.

### 35.3.7.2 NVM Programming

If the device is unlocked, it is possible to write directly to the NVM Controller or to the Flash memory using the UPDI. This will lead to unpredictable code execution if the CPU is active during the NVM programming. To avoid this, the following NVM Programming sequence has to be executed.

1. Follow the chip erase procedure, as described in [35.3.7.1 Chip Erase](#). If the part is already unlocked, this point can be skipped.
2. Enter the NVMPROG key by using the `KEY` instruction. See [Table 35-5](#) for the NVMPROG signature.
3. **Optional:** Read the NVM Programming Key Status (NVMPROG) bit from the ASI Key Status (UPDI.KEY\_STATUS) register to see if the key has been activated.

4. Write the signature to the Reset Request (RSTREQ) bit in the ASI Reset Request (UPDI.ASI\_RESET\_REQ) register. This will issue a System Reset.
5. Write 0x00 to the ASI Reset Request (UPDI.ASI\_RESET\_REQ) register to clear the System Reset.
6. Read the NVM Programming Key Status (NVMPROG) bit from the ASI System Status (UPDI.ASI\_SYS\_STATUS) register.
7. NVM Programming can start when the NVMPROG bit is '1'. If the NVMPROG bit is '0', return to step 6.
8. Write data to NVM through the UPDI.
9. Write the signature to the Reset Request (RSTREQ) bit in the ASI Reset Request (UPDI.ASI\_RESET\_REQ) register. This will issue a System Reset.
10. Write 0x00 to the ASI Reset Request (UPDI.ASI\_RESET\_REQ) register to clear the System Reset.
11. Programming is complete.

### 35.3.7.3 User Row Programming

The User Row Programming feature allows programming new values to the user row (USERROW) on a locked device. To program with this functionality enabled, the following sequence must be followed:

1. Enter the USERROW-Write key located in [Table 35-5](#) by using the KEY instruction. See [Table 35-5](#) for the USERROW-Write signature.
2. **Optional:** Read the User Row Write Key Status (UROWWRITE) bit from the ASI Key Status (UPDI.ASI\_KEY\_STATUS) register to see if the key has been activated.
3. Write the signature to the Reset Request (RSTREQ) bit in the ASI Reset Request (UPDI.ASI\_RESET\_REQ) register. This will issue a System Reset.
4. Write 0x00 to the ASI Reset Request (UPDI.ASI\_RESET\_REQ) register to clear the System Reset.
5. Read the Start User Row Programming (UROWPROG) bit from the ASI System Status (UPDI.ASI\_SYS\_STATUS) register.
6. User Row Programming can start when the UROWPROG bit is '1'. If UROWPROG is '0', return to step 5.
7. The data to be written to the User Row must first be written to a buffer in the RAM. The writable area in the RAM has a size of 32 bytes, and it is only possible to write user row data to the first 32 byte addresses of the RAM. Addressing outside this memory range will result in a nonexecuted write. The data will map 1:1 with the user row space when the data is copied into the user row upon completion of the Programming sequence.
8. When all user row data has been written to the RAM, write the User Row Programming Done (UROWDONE) bit in the ASI System Control A (UPDI.ASI\_SYS\_CTRLA) register.
9. Read the Start User Row Programming (UROWPROG) bit from the ASI System Status (UPDI.ASI\_SYS\_STATUS) register.
10. The User Row Programming is completed when UROWPROG bit is '0'. If UROWPROG bit is '1', return to step 9.
11. Write to the User Row Write Key Status (UROWWRITE) bit in the ASI Key Status (UPDI.ASI\_KEY\_STATUS) register.
12. Write the signature to the Reset Request (RSTREQ) bit in the ASI Reset Request (UPDI.ASI\_RESET\_REQ) register. This will issue a System Reset.
13. Write 0x00 to the ASI Reset Request (UPDI.ASI\_RESET\_REQ) register to clear the System Reset.
14. The User Row Programming is complete.

It is not possible to read back data from the RAM in this mode. Only writes to the first 32 bytes of the RAM are allowed.

### 35.3.8 Events

The UPDI can generate the following events:

Table 35-6. Event Generators in UPDI

Generator Name		Description	Event Type	Generating Clock Domain	Length of Event
Module	Event				
UPDI	SYNCH	SYNCH character	Level	CLK_UPDI	SYNCH char on UPDI pin synchronized to CLK_UPDI

This event is set on the UPDI clock for each detected positive edge in the SYNCH character, and it is not possible to disable this event from the UPDI.

The UPDI has no event users.

Refer to the *Event System* section for more details regarding event types and Event System configuration.

### 35.3.9 Sleep Mode Operation

The UPDI PHY layer runs independently of all sleep modes, and the UPDI is always accessible for a connected debugger independent of the device's sleep state. If the system enters a sleep mode that turns the system clock off, the UPDI will not be able to access the system bus and read memories and peripherals. When enabled, the UPDI will request the system clock so that the UPDI always has contact with the rest of the device. Thus, the UPDI PHY layer clock is unaffected by the sleep mode's settings. By reading the System Domain in Sleep (INSLEEP) bit in the ASI System Status (UPDI.ASI\_SYS\_STATUS) register, it is possible to monitor if the system domain is in a sleep mode.

It is possible to prevent the system clock from stopping when going into a sleep mode, by writing to the Request System Clock (CLKREQ) bit in the ASI System Control A (UPDI.ASI\_SYS\_CTRLA) register. If this bit is set, the system sleep mode state is emulated, and the UPDI can access the system bus and read the peripheral registers even in the deepest sleep modes.

The CLKREQ bit is by default '1' when the UPDI is enabled, which means that the default operation is keeping the system clock in ON state during the sleep modes.

### 35.4 Register Summary

Offset	Name	Bit Pos.	7	6	5	4	3	2	1	0
0x00	<a href="#">STATUSA</a>	7:0	UPDIREV[3:0]							
0x01	<a href="#">STATUSB</a>	7:0							PESIG[2:0]	
0x02	<a href="#">CTRLA</a>	7:0	IBDLY		PARD	DTD	RSD		GTVAL[2:0]	
0x03	<a href="#">CTRLB</a>	7:0				NACKDIS	CCDETDIS	UPDIDIS		
0x04	Reserved									
0x06										
0x07	<a href="#">ASI_KEY_STATUS</a>	7:0			UROWWRITE	NVMPROG	CHIPERASE			
0x08	<a href="#">ASI_RESET_REQ</a>	7:0	RSTREQ[7:0]							
0x09	<a href="#">ASI_CTRLA</a>	7:0							UPDICKDIV[1:0]	
0x0A	<a href="#">ASI_SYS_CTRLA</a>	7:0							UROWDONE	CLKREQ
0x0B	<a href="#">ASI_SYS_STATUS</a>	7:0		ERASE_FAILED	SYSRST	INSLEEP	NVMPROG	UROWPROG		LOCKSTATUS
0x0C	<a href="#">ASI_CRC_STATUS</a>	7:0							CRC_STATUS[2:0]	

### 35.5 Register Description

These registers are readable only through the UPDI with special instructions and are not readable through the CPU.

**35.5.1 Status A**

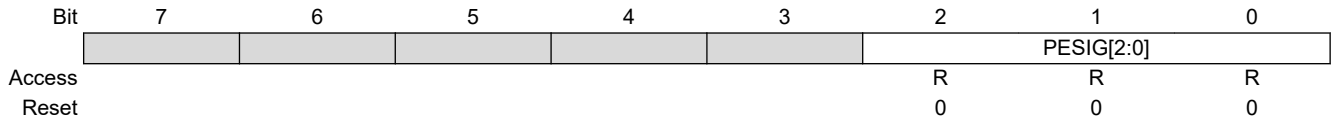
**Name:** STATUSA  
**Offset:** 0x00  
**Reset:** 0x10  
**Property:** -

	7	6	5	4	3	2	1	0
	UPDIREV[3:0]							
Access	R	R	R	R				
Reset	0	0	0	1				

**Bits 7:4 – UPDIREV[3:0]** UPDI Revision  
 This bit field contains the revision of the current UPDI implementation.

### 35.5.2 Status B

**Name:** STATUSB  
**Offset:** 0x01  
**Reset:** 0x00  
**Property:** -



**Bits 2:0 – PESIG[2:0]** UPDI Error Signature

This bit field describes the UPDI error signature and is set when an internal UPDI Error condition occurs. The PESIG bit field is cleared on a read from the debugger.

**Table 35-7. Valid Error Signatures**

PESIG[2:0]	Error Type	Error Description
0x0	No error	No error detected (Default)
0x1	Parity error	Wrong sampling of the Parity bit
0x2	Frame error	Wrong sampling of the Stop bits
0x3	Access Layer Time-Out Error	UPDI can get no data or response from the Access layer
0x4	Clock Recovery error	Wrong sampling of the Start bit
0x5	-	Reserved
0x6	Bus error	Address error or access privilege error
0x7	Contention error	Signalize Driving Contention on the UPDI pin



## 35.5.3 Control A

**Name:** CTRLA  
**Offset:** 0x02  
**Reset:** 0x00  
**Property:** -

Bit	7	6	5	4	3	2	1	0
	IBDLY		PARD	DTD	RSD	GTVAL[2:0]		
Access	R/W		R/W	R/W	R/W	R/W	R/W	R/W
Reset	0		0	0	0	0	0	0

**Bit 7 – IBDLY** Inter-Byte Delay Enable

Writing a '1' to this bit enables a fixed-length inter-byte delay between each data byte transmitted from the UPDI when doing multi-byte LD(S). The fixed length is two IDLE bits.

**Bit 5 – PARD** Parity Disable

Writing a '1' to this bit will disable the parity detection in the UPDI by ignoring the Parity bit. This feature is recommended to be used only during testing.

**Bit 4 – DTD** Disable Time-Out Detection

Writing a '1' to this bit will disable the time-out detection on the PHY layer, which requests a response from the ACC layer within a specified time (65536 UPDI clock cycles).

**Bit 3 – RSD** Response Signature Disable

Writing a '1' to this bit will disable any response signatures generated by the UPDI. This reduces the protocol overhead to a minimum when writing large blocks of data to the NVM space. When accessing the system bus, the UPDI may experience delays. If the delay is predictable, the response signature may be disabled, otherwise loss of data may occur.

**Bits 2:0 – GTVAL[2:0]** Guard Time Value

This bit field selects the guard time value that will be used by the UPDI when the transmission direction switches from RX to TX.

Value	Description
0x0	UPDI guard time: 128 cycles (default)
0x1	UPDI guard time: 64 cycles
0x2	UPDI guard time: 32 cycles
0x3	UPDI guard time: 16 cycles
0x4	UPDI guard time: 8 cycles
0x5	UPDI guard time: 4 cycles
0x6	UPDI guard time: 2 cycles
0x7	Reserved

**35.5.4 Control B**

**Name:** CTRLB  
**Offset:** 0x03  
**Reset:** 0x00  
**Property:** -

	7	6	5	4	3	2	1	0
				NACKDIS	CCDETDIS	UPDIDIS		
Access				R/W	R/W	R/W		
Reset				0	0	0		

**Bit 4 – NACKDIS** Disable NACK Response

Writing a '1' to this bit disables the NACK signature sent by the UPDI when a System Reset is issued during ongoing LD(S) and ST(S) operations.

**Bit 3 – CCDETDIS** Collision and Contention Detection Disable

Writing a '1' to this bit disables the contention detection. Writing a '0' to this bit enables the contention detection.

**Bit 2 – UPDIDIS** UPDI Disable

Writing a '1' to this bit disables the UPDI PHY interface. The clock request from the UPDI is lowered, and the UPDI is reset. All the UPDI PHY configurations and keys will be reset when the UPDI is disabled.

### 35.5.5 ASI Key Status

**Name:** ASI\_KEY\_STATUS  
**Offset:** 0x07  
**Reset:** 0x00  
**Property:** -

Bit	7	6	5	4	3	2	1	0
			UROWWRITE	NVMPROG	CHIPERASE			
Access			R/W	R	R			
Reset			0	0	0			

#### Bit 5 – UROWWRITE User Row Write Key Status

This bit is set to '1' if the UROWWRITE key is successfully decoded. This bit must be written as the final part of the user row write procedure to correctly reset the programming session.

#### Bit 4 – NVMPROG NVM Programming Key Status

This bit is set to '1' if the NVMPROG key is successfully decoded. The bit is cleared when the NVM Programming sequence is initiated, and the NVMPROG bit in ASI\_SYS\_STATUS is set.

#### Bit 3 – CHIPERASE Chip Erase Key Status

This bit is set to '1' if the Chip Erase key is successfully decoded. The bit is cleared by the Reset Request issued as part of the Chip Erase sequence described in the [35.3.7.1 Chip Erase](#) section.

### 35.5.6 ASI Reset Request

**Name:** ASI\_RESET\_REQ  
**Offset:** 0x08  
**Reset:** 0x00  
**Property:** -

A Reset is signaled to the System when writing the Reset signature to this register.

Bit	7	6	5	4	3	2	1	0
	RSTREQ[7:0]							
Access	R/W	R/W	R/W	R/W	R/W	R/W	R/W	R/W
Reset	0	0	0	0	0	0	0	0

#### Bits 7:0 – RSTREQ[7:0] Reset Request

The UPDI will not be reset when issuing a System Reset from this register.

Value	Name	Description
0x00	RUN	Clear Reset condition
0x59	RESET	Normal Reset
Other		Reset condition is cleared

### 35.5.7 ASI Control A

**Name:** ASI\_CTRLA  
**Offset:** 0x09  
**Reset:** 0x03  
**Property:** -

Bit	7	6	5	4	3	2	1	0
							UPDICKDIV[1:0]	
Access							R/W	R/W
Reset							1	1

**Bits 1:0 – UPDICKDIV[1:0]** UPDI Clock Divider Select

This bit field selects the prescaler setting for the UPDI internal oscillator. The default setting after Reset and enable is 4 MHz.

Value	Description
0x0	32 MHz UPDI clock
0x1	16 MHz UPDI clock
0x2	8 MHz UPDI clock
0x3	4 MHz UPDI clock

**35.5.8 ASI System Control A**

**Name:** ASI\_SYS\_CTRLA  
**Offset:** 0x0A  
**Property:** -

	7	6	5	4	3	2	1	0
							UROWDONE	CLKREQ
Access							R/W	R/W
Reset							0	0

**Bit 1 – UROWDONE** User Row Programming Done

This bit must be written when the user row data have been written to the RAM. Writing a '1' to this bit will start the process of programming the user row data to the Flash.

If this bit is written before the user row data is written to the RAM by the UPDI, the CPU will proceed without the written data.

This bit is writable only if the USERROW-Write key is successfully decoded.

**Bit 0 – CLKREQ** Request System Clock

If this bit is written to '1', the ASI is requesting the system clock, independent of the system sleep modes. This makes it possible for the UPDI to access the ACC layer even if the system is in a sleep mode.

Writing a '0' to this bit will lower the clock request.

This bit is set by default when the UPDI is enabled.

35.5.9 ASI System Status

**Name:** ASI\_SYS\_STATUS  
**Offset:** 0x0B  
**Reset:** 0x01  
**Property:** -

Bit	7	6	5	4	3	2	1	0
		ERASE_FAILED	SYSRST	INSLEEP	NVMPROG	UROWPROG		LOCKSTATUS
Access		R	R	R	R	R		R
Reset		0	0	0	0	0		1

**Bit 6 – ERASE\_FAILED** Chip Erase Key Failed  
 This bit is set to '1' if the chip erase has failed. This bit is set to '0' on Reset. A Reset held from the ASI\_RESET\_REQ register will also affect this bit.

**Bit 5 – SYSRST** System Reset Active  
 When this bit is set to '1', there is an active Reset on the system domain. When this bit is set to '0', the system is not in the Reset state.  
 This bit is set to '0' on read.  
 A Reset held from the ASI\_RESET\_REQ register will also affect this bit.

**Bit 4 – INSLEEP** System Domain in Sleep  
 When this bit is set to '1', the system domain is in Idle or deeper sleep mode. When this bit is set to '0', the system is not in any sleep mode.

**Bit 3 – NVMPROG** Start NVM Programming  
 When this bit is set to '1', NVM Programming can start from the UPDI.  
 When the UPDI is done, the system must be reset through the UPDI Reset register.

**Bit 2 – UROWPROG** Start User Row Programming  
 When this bit is set to '1', User Row Programming can start from the UPDI.  
 When the User Row data have been written to the RAM, the UROWDONE bit in the ASI\_SYS\_CTRLA register must be written.

**Bit 0 – LOCKSTATUS** NVM Lock Status  
 When this bit is set to '1', the device is locked. If a chip erase is done, and the lock bits are set to '0', this bit will be read as '0'.

### 35.5.10 ASI CRC Status

**Name:** ASI\_CRC\_STATUS  
**Offset:** 0x0C  
**Reset:** 0x00  
**Property:** -

Bit	7	6	5	4	3	2	1	0
						CRC_STATUS[2:0]		
Access						R	R	R
Reset						0	0	0

#### Bits 2:0 – CRC\_STATUS[2:0] CRC Execution Status

This bit field signalizes the status of the CRC conversion. This bit field is one-hot encoded.

Value	Name	Description
0x0	DISABLED	Not enabled
0x1	BUSY	CRC enabled, busy
0x2	PASS	CRC enabled, done with PASS signature
0x4	FAIL	CRC enabled, done with FAILED signature



## **36. Instruction Set Summary**

The instruction set summary can be found as part of the *AVR Instruction Set Manual*, located at [www.microchip.com/DS40002198](http://www.microchip.com/DS40002198). Refer to the CPU version called AVRxt, for details regarding the devices documented in this data sheet.

## 37. Electrical Characteristics

### 37.1 Disclaimer

All typical values are measured at  $T = 25^{\circ}\text{C}$  and  $V_{\text{DD}} = 3.0\text{V}$  unless otherwise specified. All minimum and maximum values are valid across operating temperature and voltage unless otherwise specified.

Typical values given should be considered for design guidance only, and actual part variation around these values is expected.

### 37.2 Absolute Maximum Ratings

Stresses beyond those listed in this section may cause permanent damage to the device. This is a stress rating only and functional operation of the device at these or other conditions beyond those indicated in the operational sections of this specification is not implied. Exposure to absolute maximum rating conditions for extended periods may affect device reliability.

**Table 37-1. Absolute Maximum Ratings**

Parameter	Condition	Rating	Units
Ambient temperature under bias		-40 to +125	$^{\circ}\text{C}$
Storage temperature		-65 to +150	$^{\circ}\text{C}$
<b>Voltage on pins with respect to GND</b>			
• On the $V_{\text{DD}}$ pin		-0.3 to +6.5	V
• On the $\overline{\text{RESET}}$ pin		-0.3 to $(V_{\text{DD}} + 0.3)$	V
• On all other pins		-0.3 to $(V_{\text{DD}} + 0.3)$	V
<b>Maximum current</b>			
• On the GND pin <sup>(1)</sup>	$-40^{\circ}\text{C} \leq T_{\text{A}} \leq +85^{\circ}\text{C}$	350	mA
	$+85^{\circ}\text{C} < T_{\text{A}} \leq +125^{\circ}\text{C}$	120	mA
• On the $V_{\text{DD}}$ pin <sup>(1)</sup>	$-40^{\circ}\text{C} \leq T_{\text{A}} \leq +85^{\circ}\text{C}$	350	mA
	$+85^{\circ}\text{C} < T_{\text{A}} \leq +125^{\circ}\text{C}$	120	mA
• On any standard I/O pin		$\pm 50$	mA
Clamp current, $I_{\text{K}}$ ( $V_{\text{PIN}} < 0$ or $V_{\text{PIN}} > V_{\text{DD}}$ )		$\pm 20$	mA
Total power dissipation <sup>(2)</sup>		800	mW
<b>Note:</b>			
1. The maximum current rating requires even load distribution across I/O pins. The maximum current rating may be limited by the device package power dissipation characterizations, see <i>Thermal Characteristics</i> section to calculate device specifications.			
2. Power dissipation is calculated as follows: $P_{\text{DIS}} = V_{\text{DD}} \times \{I_{\text{DD}} - \sum I_{\text{OH}}\} + \sum \{(V_{\text{DD}} - V_{\text{OH}}) \times I_{\text{OH}}\} + \sum (V_{\text{OI}} \times I_{\text{OL}})$			

### 37.3 Standard Operating Conditions

The device must operate within the ratings listed in this section for all other electrical characteristics and typical characteristics of the device to be valid.

**Table 37-2. General Operating Conditions**

Operating Voltage	$V_{\text{DDMIN}} \leq V_{\text{DD}} \leq V_{\text{DDMAX}}$
Operating Temperature	$T_{\text{A\_MIN}} \leq T_{\text{A}} \leq T_{\text{A\_MAX}}$

The standard operating conditions for any device are defined as:

**Table 37-3. Standard Operating Conditions**

Parameter	Ratings	Units	
<b>V<sub>DD</sub> — Operating Supply Voltage<sup>(1)</sup></b>			
AVR128DA28/32/48/64	V <sub>DDMIN</sub> (F <sub>OSC</sub> ≤ 24 MHz)	+1.8	V
	V <sub>DDMAX</sub>	+5.5	V
<b>T<sub>A</sub> — Operating Ambient Temperature Range</b>			
Industrial temperature	T <sub>A_MIN</sub>	-40	°C
	T <sub>A_MAX</sub>	+85	°C
Extended temperature	T <sub>A_MIN</sub>	-40	°C
	T <sub>A_MAX</sub>	+125	°C
<b>Note:</b>			
1. Refer to <i>Supply Voltage</i> Parameter in the <i>Electrical Characteristics</i> section.			

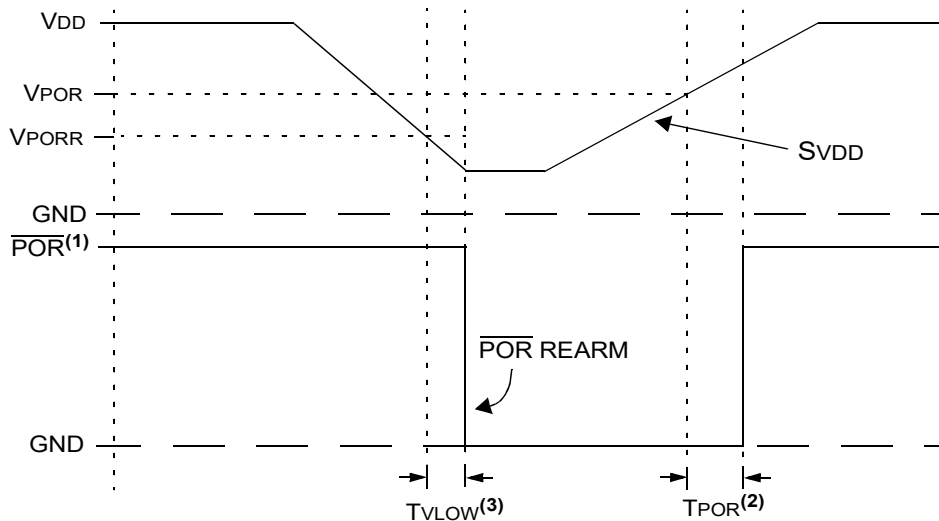
## 37.4 DC Characteristics

### 37.4.1 Supply Voltage

**Table 37-4. Supply Voltage**

Symbol	Min.	Typ.	Max.	Units	Conditions
<b>Supply Voltage</b>					
V <sub>DD</sub>	1.8	—	5.5	V	
Slew Rate	0.25	—	—	V/μs	1.8V ≤ V <sub>DD</sub> ≤ 5.5V
<b>RAM Data Retention<sup>(1)</sup></b>					
V <sub>DR</sub>	1.7	—	—	V	Device in Power-Down mode
<b>Power-on Reset Release Voltage<sup>(2)</sup></b>					
V <sub>POR</sub>	—	1.6	—	V	BOD disabled <sup>(3)</sup>
<b>Power-on Reset Rearm Voltage<sup>(2)</sup></b>					
V <sub>PORR</sub>	—	1.25	—	V	BOD disabled <sup>(3)</sup>
<b>V<sub>DD</sub> Rise Rate to ensure internal Power-on Reset signal<sup>(2)</sup></b>					
S <sub>VDD</sub>	0.05	—	—	V/ms	BOD disabled <sup>(3)</sup>
<b>Notes:</b>					
1. This is the limit to which V <sub>DD</sub> can be lowered in sleep mode without losing RAM data.					
2. Refer to <a href="#">Figure 37-1</a> .					
3. Refer to <i>Reset, WDT, Oscillator Start-up Timer, Power-up Timer, Brown-out Detector Specifications</i> section for BOD trip point information.					

Figure 37-1. POR and POR Rearm with Slow Rising V<sub>DD</sub>



Notes:

1. When  $\overline{\text{POR}}$  is low, the device is held in Reset.
2. T<sub>POR</sub> 1 μs typical.
3. T<sub>VLOW</sub> 2.7 μs typical.

37.4.2 Power Consumption

Table 37-5. Power Consumption in Active and Idle Mode

System Power Consumption Measured with Peripherals Disabled and I/O Ports Driven Low with Inputs Disabled						
Symbol	Description	Min.	Typ.	Max.	Units	Conditions
I <sub>DD</sub>	Active power consumption	—	4.7	—	mA	OSCHF = 24 MHz
		—	1.1	—	mA	OSCHF = 4 MHz
		—	4.7	—	μA	OSC32K = 32.768 kHz
		—	4.4	—	mA	EXTCLK = 24 MHz
		—	910	—	μA	EXTCLK = 4 MHz
		—	8.2	—	μA	XOSC32K = 32.768 kHz (High Power)
		—	6.3	—	μA	XOSC32K = 32.768 kHz (Low Power)
I <sub>DDIDLE</sub>	Idle power consumption	—	2.3	—	mA	OSCHF = 24 MHz
		—	630	—	μA	OSCHF = 4 MHz
		—	3.1	—	μA	OSC32K = 32.768 kHz
		—	2.0	—	mA	EXTCLK = 24 MHz
		—	480	—	μA	EXTCLK = 4 MHz
		—	6.8	—	μA	XOSC32K = 32.768 kHz (High Power)
		—	4.8	—	μA	XOSC32K = 32.768 kHz (Low Power)

.....continued

System Power Consumption Measured with Peripherals Disabled and I/O Ports Driven Low with Inputs Disabled						
Symbol	Description	Min.	Typ.	Max.	Units	Conditions
IDD <sub>SBY</sub>	Standby power consumption	—	3.2	—	μA	RTC running at 1.024 kHz from XOSC32K (CL = 9 pF, High Power)
		—	1.6	—	μA	RTC running at 1.024 kHz from XOSC32K (CL = 9 pF, Low Power)
		—	1.2	—	μA	RTC running at 1.024 kHz from OSC32K
IDD <sub>BASE</sub>	Minimum power consumption in different sleep modes	—	3.1	—	μA	Idle mode, all peripherals disabled
		—	2.3	—	μA	Standby mode, all peripherals disabled
		—	650	—	nA	Power-Down mode, all peripherals disabled
IRST	Reset power consumption	—	170	—	μA	RESET line pulled low

### 37.4.3 Peripherals Power Consumption

The table below can be used to calculate the additional current consumption for the different I/O peripherals in the various operating modes. Some peripherals will request the clock to be enabled when operating in STANDBY. Refer to the peripheral section for further information.

**Table 37-6. Peripherals Power Consumption<sup>(1)</sup>**

OSCHF at 4 MHz Used as Clock Source, Except Where Otherwise Specified In Standby Sleep Mode, Except Where Otherwise Specified						
Symbol	Description	Min.	Typ.	Max.	Units	Conditions
IDD <sub>WDT</sub>	Low-Frequency Internal Oscillator/WDT	—	600	—	nA	
IDD <sub>VREF</sub>	ADC0REF enabled	—	160	—	μA	V <sub>REF</sub> = 2.048V
	ACREF enabled	—	71	—	μA	
	DACREF enabled	—	40	—	μA	
IDD <sub>BOD</sub>	Brown-out Detect (BOD) continuous	—	17	—	μA	
	Brown-out Detect (BOD) sampling @128 Hz	—	800	—	nA	
	Brown-out Detect (BOD) sampling @32 Hz	—	600	—	nA	
IDD <sub>TCA</sub>	TCA	—	6.3	—	μA	HFOSC = 4 MHz CLK_PER = HFOSC/4 = 1 MHz
IDD <sub>TCB</sub>	TCB	—	3.7	—	μA	
IDD <sub>TCD</sub>	TCD	—	5.3	—	μA	
IDD <sub>RTC</sub>	RTC	—	820	—	nA	CLK_RTC = 32.768 kHz Internal Oscillator
IDD <sub>OSC32K</sub>	32.768 kHz Internal Oscillator (OSC32K)	—	510	—	nA	

.....continued

**OSCHF at 4 MHz Used as Clock Source, Except Where Otherwise Specified  
In Standby Sleep Mode, Except Where Otherwise Specified**

Symbol	Description	Min.	Typ.	Max.	Units	Conditions
I <sub>DD_XOSC32K</sub>	32.768 kHz Crystal Oscillator (XOSC32K)	—	2.4	—	μA	XOSC32K High Power, C <sub>L</sub> = 9 pF
		—	580	—	nA	XOSC32K Low Power, C <sub>L</sub> = 9 pF
I <sub>DD_ADC</sub>	ADC - Nonconverting	—	67	—	μA	
	ADC @60 ksps <sup>(2)</sup>	—	680	—	μA	
	ADC @120 ksps <sup>(2)</sup>	—	700	—	μA	
I <sub>DD_AC</sub>	Analog Comparator	—	70	—	μA	Power Profile 0
		—	17	—	μA	Power Profile 1
		—	12	—	μA	Power Profile 2
I <sub>DD_DAC</sub>	DAC + DACOUT	—	120	—	μA	DACVREF = V <sub>DD</sub> /2
	DAC (V <sub>DD</sub> )	—	8.6	—	μA	DACVREF = V <sub>DD</sub> /2
I <sub>DD_UART</sub>	UART Enabled @9600 Baud	—	36	—	μA	
I <sub>DD_SPI</sub>	SPI Master @100 kHz	—	2.1	—	μA	
I <sub>DD_TWI</sub>	TWI Master @100 kHz	—	24	—	μA	
	TWI Slave @100 kHz	—	17	—	μA	
I <sub>DD_NVM_ERASE</sub>	Flash Programming Erase	—	1.5	—	mA	
I <sub>DD_NVM_WRITE</sub>	Flash Programming Write	—	3	—	mA	

**Notes:**

- Current consumption of the module only. To calculate the total internal power consumption of the microcontroller, add this value to the base power consumption given in the *Power Consumption* section in *Electrical Characteristics*.
- Average power consumption with ADC active in Free-Running mode.

### 37.4.4 I/O Pin Characteristics

**Table 37-7. I/O Pin Characteristics**

Symbol	Description	Min.	Typ.	Max.	Units	Conditions
<b>Input Low Voltage</b>						
V <sub>IL</sub>	I/O PORT:					
	• with Schmitt Trigger buffer	—	—	0.2 V <sub>DD</sub>	V	
	• with I <sup>2</sup> C levels	—	—	0.3 V <sub>DD</sub>	V	
	• with SMBus 3.0 levels	—	—	0.8	V	
	RESET Pin	—	—	0.2 V <sub>DD</sub>	V	
<b>Input High Voltage</b>						

.....continued						
Symbol	Description	Min.	Typ.	Max.	Units	Conditions
V <sub>IH</sub>	I/O PORT:					
	• with Schmitt Trigger buffer	0.8V <sub>DD</sub>	—	—	V	
	• with I <sup>2</sup> C levels	0.7 V <sub>DD</sub>	—	—	V	
	• with SMBus 3.0 levels	1.35	—	—	V	
	RESET Pin	0.8 V <sub>DD</sub>	—	—	V	
<b>Input Leakage Current<sup>(1)</sup></b>						
I <sub>IL</sub>	I/O PORTS	—	±5	±125	nA	GND ≤ V <sub>PIN</sub> ≤ V <sub>DD</sub> , pin at high-impedance, 85°C
		—	±5	±1000	nA	GND ≤ V <sub>PIN</sub> ≤ V <sub>DD</sub> , pin at high-impedance, 125°C
	RESET Pin <sup>(2)</sup>	—	±50	±200	nA	GND ≤ V <sub>PIN</sub> ≤ V <sub>DD</sub> , pin at high-impedance, 85°C
<b>Pull-up Current</b>						
I <sub>PUR</sub>		80	140	200	μA	V <sub>DD</sub> = 3.0V, V <sub>PIN</sub> = GND
<b>Output Low Voltage</b>						
V <sub>OL</sub>	Standard I/O Ports	—	—	0.6	V	I <sub>OL</sub> = 10 mA, V <sub>DD</sub> = 3.0V
<b>Output High Voltage</b>						
V <sub>OH</sub>	Standard I/O Ports	V <sub>DD</sub> -0.7	—	—	V	I <sub>OH</sub> = 6 mA, V <sub>DD</sub> = 3.0V
<b>Pin Capacitance</b>						
C <sub>IO</sub>	All I/O Pins	—	5	—	pF	
<b>Notes:</b>						
1. The negative current is defined as current sourced by the pin.						
2. The leakage current on the RESET pin is strongly dependent on the applied voltage level. The specified levels represent normal operating conditions. Higher leakage current may be measured at different input voltages.						

### 37.4.5 Memory Programming Specifications

Table 37-8. Memory Programming Specifications<sup>(1)</sup>

Symbol	Description	Min.	Typ	Max.	Units	Conditions
<b>Data EEPROM Memory Specifications</b>						
E <sub>D</sub>	Data EEPROM Byte Endurance	100k	—	—	Erase/Write cycles	-40°C ≤ T <sub>A</sub> ≤ +85°C
t <sub>D_RET</sub>	Characteristic Retention	—	40	—	Year	provided no other specifications are violated
N <sub>D_REF</sub>	Total Erase/Write Cycles before Refresh	1M	4M	—	Erase/Write cycles	-40°C ≤ T <sub>A</sub> ≤ +85°C
t <sub>D_CE</sub>	Full EEPROM Erase	—	10	—	ms	
V <sub>D_RW</sub>	V <sub>DD</sub> for Read or Erase/Write operation	V <sub>DDMIN</sub>	—	V <sub>DDMAX</sub>	V	
t <sub>D_BEW</sub>	Byte Erase and Write Cycle Time	—	11	—	ms	

.....continued

Symbol	Description	Min.	Typ	Max.	Units	Conditions
<b>Program Flash Memory Specifications</b>						
Ep	Flash Memory Cell Endurance	10k	—	—	Erase/Write cycles	-40°C ≤ T <sub>A</sub> ≤ +85°C
t <sub>P_RET</sub>	Characteristic Retention	—	40	—	Year	provided no other specifications are violated
V <sub>P_RD</sub>	V <sub>DD</sub> for Read operation	V <sub>DDMIN</sub>	—	V <sub>DDMAX</sub>	V	
V <sub>P_REW</sub>	V <sub>DD</sub> for Erase/Write operation	V <sub>DD</sub> <sup>(2)</sup>	—	V <sub>DDMAX</sub>	V	
t <sub>P_PE</sub>	Page Erase	—	10	—	ms	
t <sub>P_CE</sub>	Chip Erase	—	—	—	ms	
t <sub>P_WRD</sub>	Byte/Word Write	—	70	—	μs	
<b>Notes:</b>						
1. These parameters are not tested but ensured by design.						
2. During Chip Erase the Brown-out Detector (BOD) configured with BODLEVEL0 is forced ON. If the supply voltage V <sub>DD</sub> is below V <sub>BOD</sub> for BODLEVEL0 the erase attempt will fail.						

### 37.4.6 Thermal Characteristics

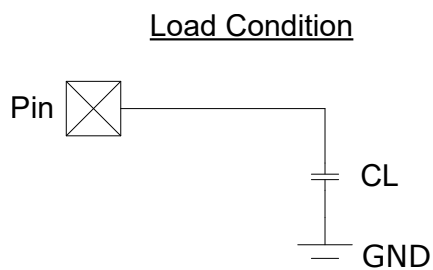
**Table 37-9. Thermal Characteristics**

Symbol	Description	Typ.	Units	Conditions
θ <sub>JA</sub>	Thermal Resistance Junction to Ambient (Thermal simulation, no airflow)	60	°C/W	28-pin PDIP package (SP)
		74	°C/W	28-pin SOIC package (SO)
		67	°C/W	28-pin SSOP package (SS)
		36	°C/W	32-pin VQFN package (RXB)
		59	°C/W	32-pin TQFP package (PT)
		34	°C/W	48-pin VQFN package (6LX)
		56	°C/W	48-pin TQFP package (PT)
		30	°C/W	64-pin VQFN package (MR)
		39	°C/W	64-pin TQFP package (PT)
T <sub>JMAX</sub>	Maximum Junction Temperature	145	°C	
<b>Notes:</b>				
1. Power dissipation is calculated as follows: P <sub>DIS</sub> = V <sub>DD</sub> × {I <sub>DD</sub> - Σ I <sub>OH</sub> } + Σ {(V <sub>DD</sub> - V <sub>OH</sub> ) × I <sub>OH</sub> } + Σ (V <sub>OI</sub> × I <sub>OL</sub> )				
2. Internal Power Dissipation is calculated as follows: P <sub>INTERNAL</sub> = I <sub>DD</sub> × V <sub>DD</sub> , where I <sub>DD</sub> is current to run the chip alone without driving any load on the output pins.				
3. Derated Power is calculated as follows: P <sub>DER</sub> = P <sub>DMAX</sub> (T <sub>J</sub> -T <sub>A</sub> )/θ <sub>JA</sub> , where T <sub>A</sub> = Ambient Temperature, T <sub>J</sub> = Junction Temperature.				



### 37.5 AC Characteristics

Figure 37-2. Load Conditions



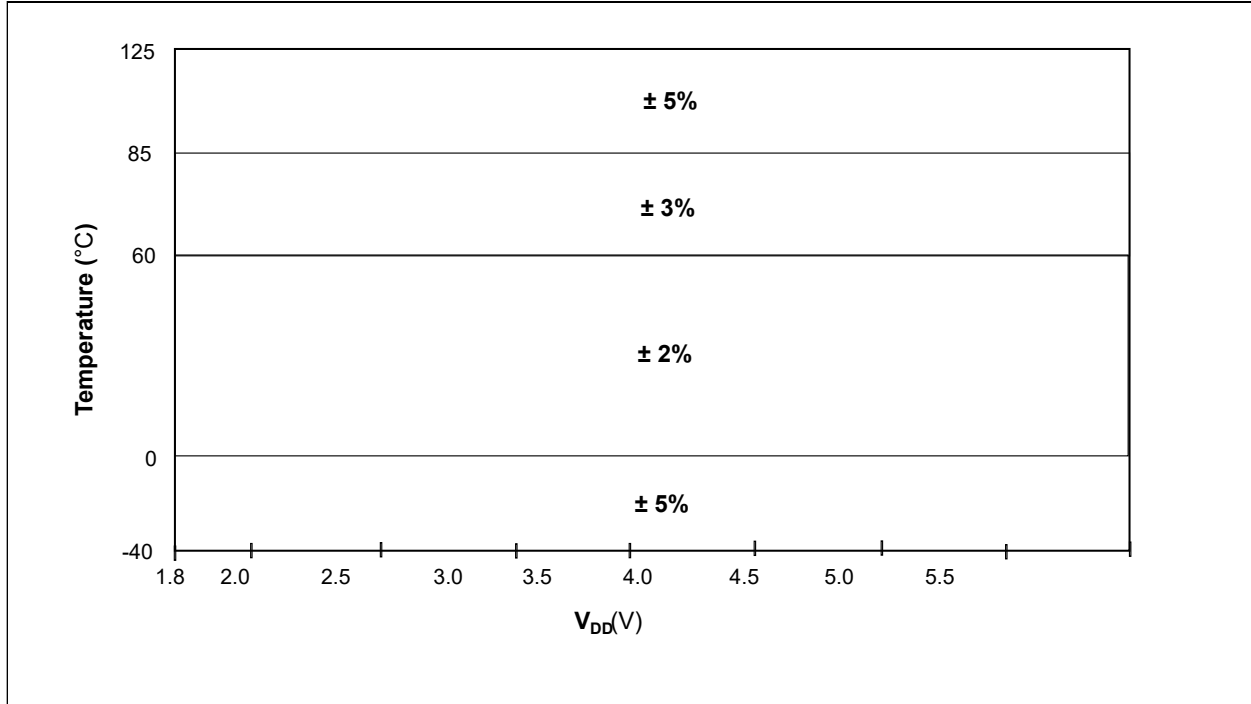
**Legend:** CL = 50 pF for all pins

#### 37.5.1 Internal Oscillator Parameters<sup>(1)</sup>

Table 37-10. Internal Oscillators Characteristics

Symbol	Description	Min.	Typ.	Max.	Units	Conditions
FOSCHF	Precision Calibrated OSCHF Frequency	—	1 (2) 2(2) 3(2) 4 8 12 16 20 24	—	MHz	
%CAL	OSCHF Tune Step Size	—	0.4	—	%	
TOSCHF_ST	OSCHF Wake-up from Sleep Start-up Time	—	11	—	μs	device in Idle or Standby mode VREGCTRL.PMODE = FULL
		—	100	—	μs	device in Power-Down mode VREGCTRL.PMODE = AUTO
FOSC32K	Internal OSC32K Frequency	—	32.768	—	kHz	
TOSC32K_ST	OSC32K Wake-up from Sleep Start-up Time	—	400	—	μs	
<b>Notes:</b>						
1. To ensure these oscillator frequency tolerances, V <sub>DD</sub> and GND must be capacitively decoupled as close to the device as possible. 0.1 μF and 0.01 μF values in parallel are recommended.						
2. These parameters are not calibrated.						

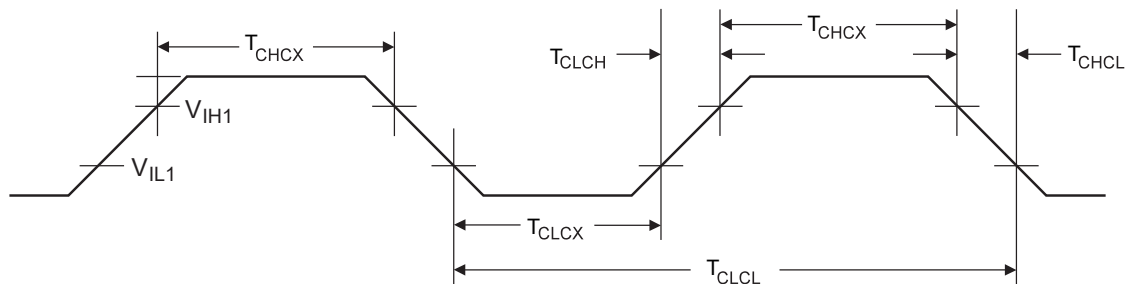
**Figure 37-3. Precision Calibrated OSCHF (4 MHz) and OSC32K Frequency Accuracy Over Device  $V_{DD}$  and Temperature**



**Table 37-11. 32.768 kHz External Crystal Oscillator (XOSC32K) Characteristics**

Symbol	Description	Min.	Typ.	Max.	Units	Conditions
FXOSC32	Frequency	—	32.768	—	kHz	
CXTAL1/XTAL2	Parastatic Pin Capacitance	—	5	—	pF	
$C_L$	Crystal Load Capacitance	—	9	—	pF	
ERS	ERS, $C_L = 9$ pF	—	—	50	k $\Omega$	
TXOSC32_ST	XOSC32 Start-up Time	—	300	—	ms	$C_L = 9$ pF, XOSC32 in High Power mode

**Figure 37-4. External Clock Waveform**



**Table 37-12. External Clock Characteristics**

Symbol	Description	Min.	Typ.	Max.	Units	Conditions
FCLCL	Clock Frequency	—	—	24	MHz	
TCLCL	Clock Period	41.6	—	—	ns	

.....continued

Symbol	Description	Min.	Typ.	Max.	Units	Conditions
TCHCX	High Time	—	40	—	%	
TCLCX	Low Time	—	40	—	%	
ΔTCLCL	Change in Period from cycle to cycle Time	—	20	—	%	

**Table 37-13. PLL Specifications**

Symbol	Description	Min.	Typ.	Max.	Units	Conditions
FPLLIN	PLL Input Frequency Range	16	—	24	MHz	
FPLLOUT	PLL Output Frequency Range	32	—	48	MHz	
FPLLST	PLL Lock Time	—	10	—	μs	

**Table 37-14. System Clock Timing Characteristics**

Symbol	Description	Min.	Typ.	Max.	Units	Conditions
<b>System Clock</b>						
FCLK_MAIN	Main Clock Frequency <sup>(2,3)</sup>	—	—	24	MHz	
FCY	Instruction Frequency	—	FCLK_MAIN	—	MHz	
TCY	Instruction Period <sup>(1)</sup>	41.6	1/FCY	—	ns	
<b>Notes:</b>						
1. Instruction Cycle Period (TCY) equals the input oscillator time base period. All specified values are based on characterization data for that particular oscillator type under standard operating conditions with the device executing code. Exceeding these specified limits may result in incorrect code execution and/or higher than expected current consumption. All devices are tested to operate at “min” values with an external clock applied to the EXTCLK pin. When an external clock input is used, the “max” cycle time limit is “DC” (no clock) for all devices.						
2. The main clock frequency (CLK_MAIN) is configured by the Clock Select (CLKSEL) bit field, as described in the <i>CLKCTRL - Clock Controller</i> section.						
3. The main clock frequency (CLK_MAIN) must meet the voltage requirements defined in the <i>Standard Operating Conditions</i> section.						

**37.5.2 Reset, WDT, Oscillator Start-up Timer, Power-up Timer, Brown-out Detector Specifications****Table 37-15. Reset, WDT, Oscillator Start-up Timer, Power-up Timer, Brown-out Detector Specifications**

Sym.	Description	Min.	Typ.	Max.	Units	Conditions
TRST	RESET Pin Pulse-Width Low to ensure Reset	2.5	—	—	μs	
RRST_UP	RESET pin pull-up resistor	—	35	—	kΩ	
TWDT	Watchdog Timer Time-out Period	—	500	—	ms	1:512 Prescaler
TSUT	Power-up Timer Period	—	65	—	ms	SUT = 0x07
TOST	Oscillator Start-up Timer Period <sup>(1)</sup>	—	1024	—	cycles	
VBOD	Brown-out Detect Voltage <sup>(2)</sup>	—	1.90	—	V	BODLEVEL0
			2.45		V	BODLEVEL1
			2.7		V	BODLEVEL2
			2.85		V	BODLEVEL3
VBOD_HYS	Brown-out Detect Hysteresis	—	44	—	mV	

.....continued

Sym.	Description	Min.	Typ.	Max.	Units	Conditions
TBOD_ST	Brown-out Detect Start-up time	—	1.9	—	µs	
TBOD_128HZ	BOD Response Time Sampling Mode @128 Hz	—	7.81	—	ms	SAMPFREQ=0
TBOD_32HZ	BOD Response Time Sampling Mode @32 Hz	—	31.25	—	ms	SAMPFREQ=1
TBOD_RST	Brown-out Reset Response Time	—	3	—	µs	

**Notes:**

1. By design, the Oscillator Start-up Timer (T<sub>OSt</sub>) counts the first 1024 cycles, independent of frequency.
2. To ensure these voltage tolerances, V<sub>DD</sub> and GND must be capacitively decoupled as close to the device as possible. 0.1 µF and 0.01 µF values in parallel are recommended.

**Table 37-16. Voltage Level Monitor Threshold Characteristics**

Symbol	Description	Min.	Typ.	Max.	Units	Conditions
VDET	Voltage detection threshold	—	5	—	% of BOD Threshold	VLMLVL = 0x01
		—	15	—	% of BOD Threshold	VLMLVL = 0x02
		—	25	—	% of BOD Threshold	VLMLVL = 0x03

### 37.5.3 Internal Voltage Reference (V<sub>REF</sub>) Characteristics

**Table 37-17. Internal Voltage Reference (V<sub>REF</sub>) Characteristics<sup>(1)</sup>**

Symbol	Description	Min.	Typ.	Max.	Units	Conditions
VVREF_1V024	Internal Voltage Reference 1.024V	-4	—	+4	%	V <sub>DD</sub> ≥ 2.5V, -40°C to 85°C
VVREF_2V048	Internal Voltage Reference 2.048V	-4	—	+4	%	V <sub>DD</sub> ≥ 2.5V, -40°C to 85°C
VVREF_4V096	Internal Voltage Reference 4.096V	-4	—	+4	%	V <sub>DD</sub> ≥ 4.55V, -40°C to 85°C
VVREF_2V500	Internal Voltage Reference 2.5V	-4	—	+4	%	V <sub>DD</sub> ≥ 2.7V, -40°C to 85°C
TVREF_ST	VREF Start-up Time	—	50	—	µs	

**Notes:**

1. These values are based on characterization and not covered by production test limits.
2. The symbol V<sub>VREF\_xVxxx</sub> refers to the respective values of the REFSEL bit fields in the VREF.ADC0REF, VREF.DAC0REF and VREF.ACREF registers.

37.5.4 USART

Figure 37-5. USART in SPI Mode - Timing Requirements in Master Mode

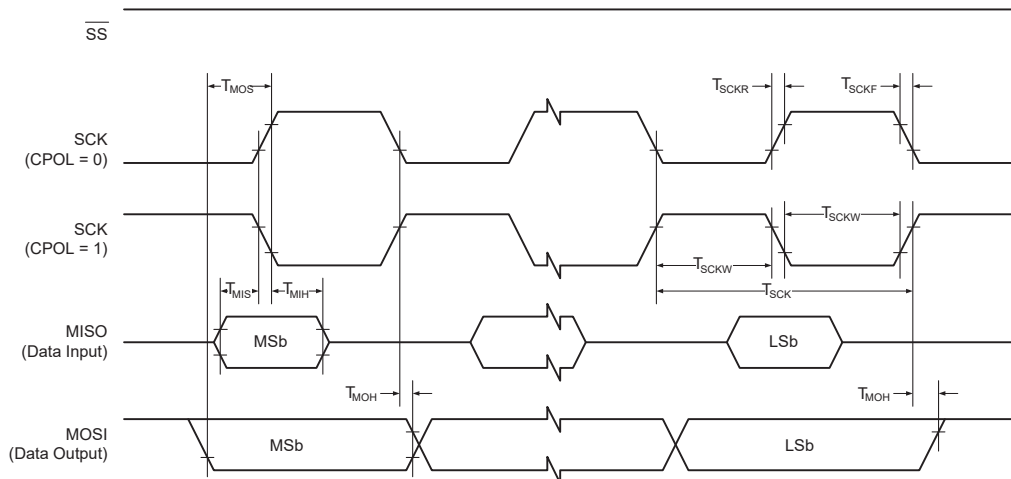


Table 37-18. USART in SPI Master Mode - Timing Characteristics

Symbol	Description	Min.	Typ.	Max.	Unit	Condition
$F_{SCK}$	SCK clock frequency	—	—	10	MHz	
$T_{SCK}$	SCK period	100	—	—	ns	
$T_{SCKW}$	SCK high/low width	—	$0.5 \times T_{SCK}$	—	ns	
$T_{SCKR}$	SCK rise time	—	2.7	—	ns	
$T_{SCKF}$	SCK fall time	—	2.7	—	ns	
$T_{MIS}$	MISO setup to SCK	—	10	—	ns	
$T_{MIH}$	MISO hold after SCK	—	10	—	ns	
$T_{MOS}$	MOSI setup to SCK	—	$0.5 \times T_{SCK}$	—	ns	
$T_{MOH}$	MOSI hold after SCK	—	1.0	—	ns	

37.5.5 SPI

Figure 37-6. SPI - Timing Requirements in Master Mode

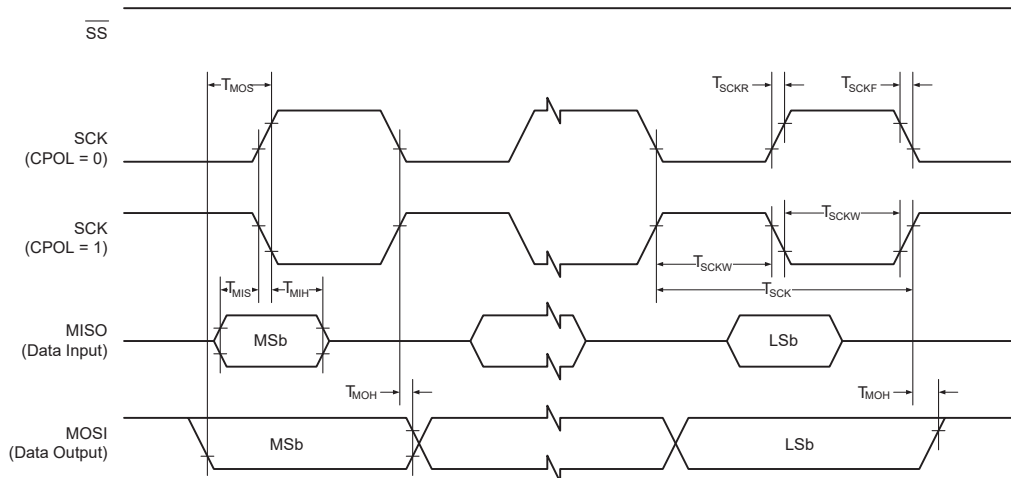


Table 37-19. SPI - Timing Characteristics in Master Mode

Symbol	Description	Min.	Typ.	Max.	Unit	Condition
$F_{SCK}$	SCK clock frequency	—	—	10	MHz	
$T_{SCK}$	SCK period	100	—	—	ns	
$T_{SCKW}$	SCK high/low width	—	$0.5 \cdot T_{SCK}$	—	ns	
$T_{SCKR}$	SCK rise time	—	2.7	—	ns	
$T_{SCKF}$	SCK fall time	—	2.7	—	ns	
$T_{MIS}$	MISO setup to SCK	—	10	—	ns	
$T_{MIH}$	MISO hold after SCK	—	10	—	ns	
$T_{MOS}$	MOSI setup to SCK	—	$0.5 \cdot T_{SCK}$	—	ns	
$T_{MOH}$	MOSI hold after SCK	—	1.0	—	ns	

Figure 37-7. SPI - Timing Requirements in Slave Mode

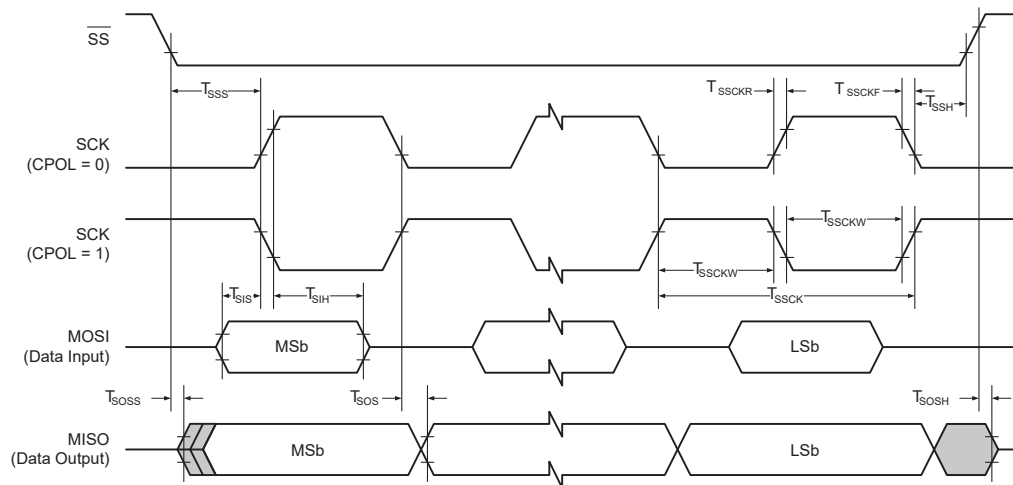


Table 37-20. SPI - Timing Characteristics in Slave Mode

Symbol	Description	Min.	Typ.	Max.	Unit	Condition
$F_{SSCK}$	Slave SCK clock frequency	—	—	5	MHz	
$T_{SSCK}$	Slave SCK period	$4 \cdot T_{CLK\_PER}$	—	—	ns	
$T_{SSCKW}$	SCK high/low width	$2 \cdot T_{CLK\_PER}$	—	—	ns	
$T_{SSCKR}$	SCK rise time	—	—	1600	ns	
$T_{SSCKF}$	SCK fall time	—	—	1600	ns	
$T_{SIS}$	MOSI setup to SCK	3.0	—	—	ns	
$T_{SIH}$	MOSI hold after SCK	$T_{CLK\_PER}$	—	—	ns	
$T_{SSS}$	SS setup to SCK	21	—	—	ns	
$T_{SSH}$	SS hold after SCK	20	—	—	ns	
$T_{SOS}$	MISO setup to SCK	—	8.0	—	ns	
$T_{SOH}$	MISO hold after SCK	—	13	—	ns	

.....continued

Symbol	Description	Min.	Typ.	Max.	Unit	Condition
T <sub>SOSS</sub>	MISO setup after SS low	—	11	—	ns	
T <sub>SOSH</sub>	MISO hold after SS low	—	8.0	—	ns	

37.5.6 TWI

Figure 37-8. TWI - Timing Requirements

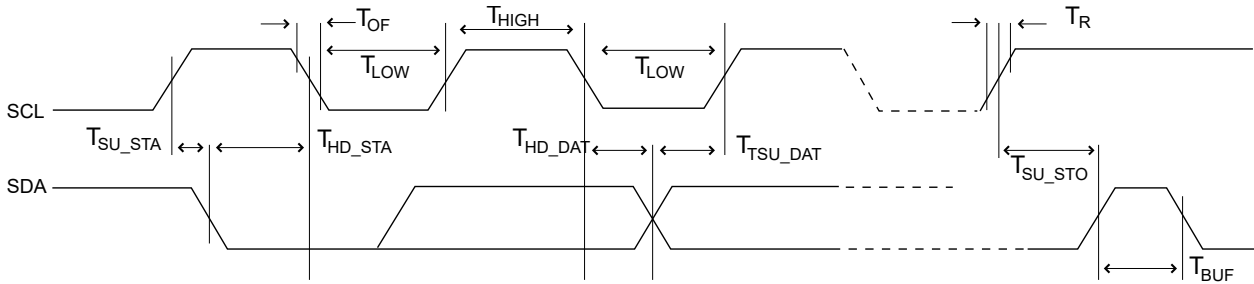


Table 37-21. TWI - Timing Characteristics

Symbol	Description	Min.	Typ.	Max.	Unit	Condition
F <sub>SCL</sub>	SCL clock frequency	0	—	1000	kHz	Max. frequency requires system clock at 10 MHz
V <sub>IH</sub>	Input high voltage	0.7×V <sub>DD</sub>	—	—	V	
V <sub>IL</sub>	Input low voltage	—	—	0.3×V <sub>DD</sub>	V	
V <sub>HYS</sub>	Hysteresis of Schmitt Trigger inputs	0.1×V <sub>DD</sub>	—	0.4×V <sub>DD</sub>	V	
V <sub>OL</sub>	Output low voltage	—	—	0.2×V <sub>DD</sub>	V	I <sub>load</sub> = 20 mA, Fast mode+
		—	—	0.4V		I <sub>load</sub> = 3 mA, Normal mode, V <sub>DD</sub> > 2V
		—	—	0.2×V <sub>DD</sub>		I <sub>load</sub> = 3 mA, Normal mode, V <sub>DD</sub> ≤ 2V
I <sub>OL</sub>	Low-level output current	3	—	—	mA	F <sub>SCL</sub> ≤ 400 kHz, V <sub>OL</sub> = 0.4V
		20	—	—		F <sub>SCL</sub> ≤ 1 MHz, V <sub>OL</sub> = 0.4V
C <sub>B</sub>	Capacitive load for each bus line	—	—	400	pF	F <sub>SCL</sub> ≤ 100 kHz
		—	—	400		F <sub>SCL</sub> ≤ 400 kHz
		—	—	550		F <sub>SCL</sub> ≤ 1 MHz
T <sub>R</sub>	Rise time for both SDA and SCL	—	—	1000	ns	F <sub>SCL</sub> ≤ 100 kHz
		20	—	300		F <sub>SCL</sub> ≤ 400 kHz
		—	—	120		F <sub>SCL</sub> ≤ 1 MHz

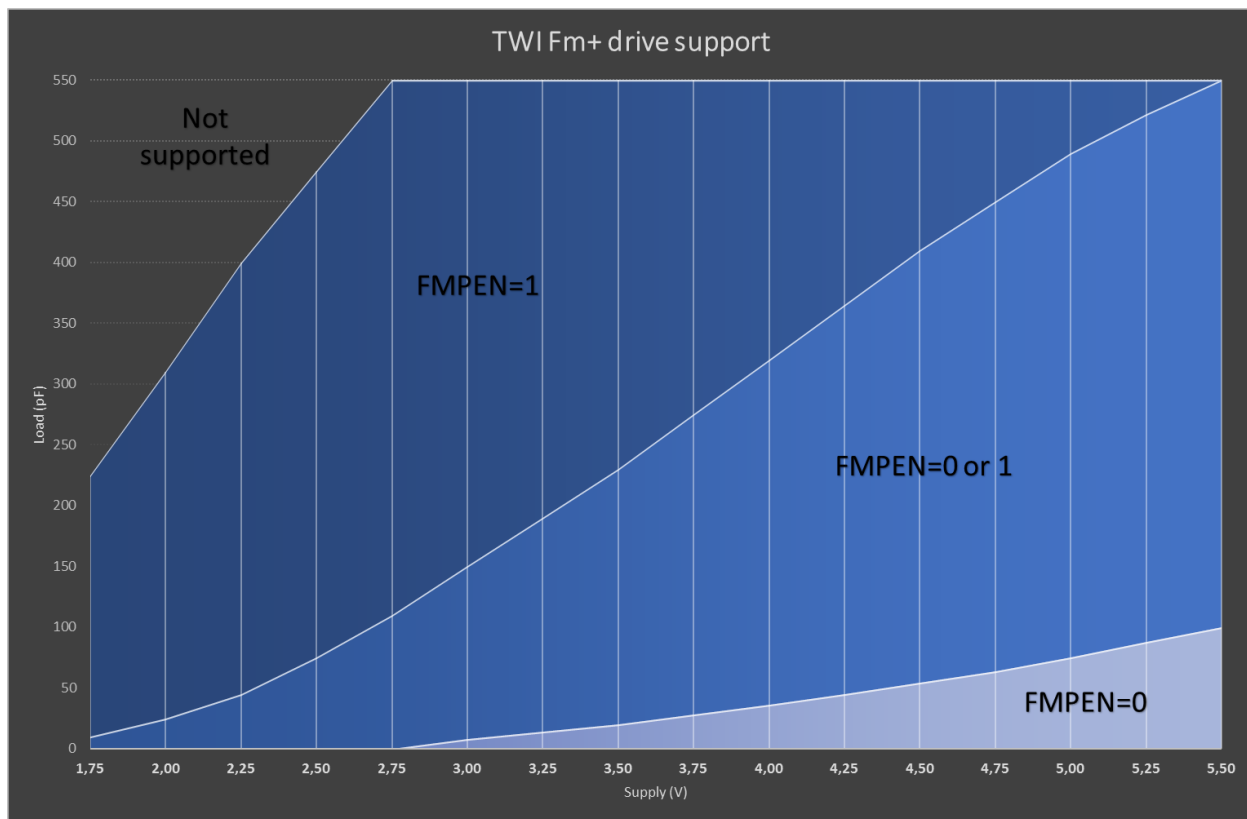
.....continued						
Symbol	Description	Min.	Typ.	Max.	Unit	Condition
T <sub>OF</sub>	Output fall time from V <sub>IHmin</sub> to V <sub>ILmax</sub>	—	—	250	ns	F <sub>SCL</sub> ≤ 100 kHz 10 pF < C <sub>B</sub> < 400 pF
		20×(V <sub>DD</sub> /5.5V)	—	250		F <sub>SCL</sub> ≤ 400 kHz 10 pF < C <sub>B</sub> < 400 pF
		20×(V <sub>DD</sub> /5.5V)	—	120		F <sub>SCL</sub> ≤ 1 MHz 10 pF < C <sub>B</sub> < 400 pF
T <sub>SP</sub>	Spikes suppressed by the input filter	0	—	50	ns	
I <sub>L</sub>	Input current for each I/O pin	—	—	1	μA	0.1×V <sub>DD</sub> < V <sub>I</sub> < 0.9×V <sub>DD</sub>
C <sub>I</sub>	Capacitance for each I/O pin	—	—	10	pF	
R <sub>P</sub>	Value of pull-up resistor	(V <sub>DD</sub> -V <sub>OL(max)</sub> )/I <sub>OL</sub>	—	1000 ns/ (0.8473×C <sub>B</sub> )	Ω	F <sub>SCL</sub> ≤ 100 kHz
		—	—	300 ns/ (0.8473×C <sub>B</sub> )		F <sub>SCL</sub> ≤ 400 kHz
		—	—	120 ns/ (0.8473×C <sub>B</sub> )		F <sub>SCL</sub> ≤ 1 MHz
T <sub>HD_STA</sub>	Hold time (repeated) Start condition	4.0	—	—	μs	F <sub>SCL</sub> ≤ 100 kHz
		0.6	—	—		F <sub>SCL</sub> ≤ 400 kHz
		0.26	—	—		F <sub>SCL</sub> ≤ 1 MHz
T <sub>LOW</sub>	Low period of SCL Clock	4.7	—	—	μs	F <sub>SCL</sub> ≤ 100 kHz
		1.3	—	—		F <sub>SCL</sub> ≤ 400 kHz
		0.5	—	—		F <sub>SCL</sub> ≤ 1 MHz
T <sub>HIGH</sub>	High period of SCL Clock	4.0	—	—	μs	F <sub>SCL</sub> ≤ 100 kHz
		0.6	—	—		F <sub>SCL</sub> ≤ 400 kHz
		0.26	—	—		F <sub>SCL</sub> ≤ 1 MHz
T <sub>SU_STA</sub>	Setup time for a repeated Start condition	4.7	—	—	μs	F <sub>SCL</sub> ≤ 100 kHz
		0.6	—	—		F <sub>SCL</sub> ≤ 400 kHz
		0.26	—	—		F <sub>SCL</sub> ≤ 1 MHz
T <sub>HD_DAT</sub>	Data hold time across all corners	—	0	—	ns	SDAHOLD[1:0] = 0x0
		30	—	300		SDAHOLD[1:0] = 0x1
		120	—	420		SDAHOLD[1:0] = 0x2
		300	—	900		SDAHOLD[1:0] = 0x3
T <sub>SU_DAT</sub>	Data setup time	250	—	—	ns	F <sub>SCL</sub> ≤ 100 kHz
		100	—	—		F <sub>SCL</sub> ≤ 400 kHz
		50	—	—		F <sub>SCL</sub> ≤ 1 MHz



.....continued

Symbol	Description	Min.	Typ.	Max.	Unit	Condition
TSU_STO	Setup time for Stop condition	4	—	—	μs	F <sub>SCL</sub> ≤ 100 kHz
		0.6	—	—		F <sub>SCL</sub> ≤ 400 kHz
		0.26	—	—		F <sub>SCL</sub> ≤ 1 MHz
TBUF	Bus free time between a Stop and Start condition	4.7	—	—	μs	F <sub>SCL</sub> ≤ 100 kHz
		1.3	—	—		F <sub>SCL</sub> ≤ 400 kHz
		0.5	—	—		F <sub>SCL</sub> ≤ 1 MHz

Figure 37-9. TWI - Fm+ Drive Support Characteristics



### 37.5.7 DAC Specifications

Table 37-22. DAC Electrical Specifications

V<sub>DD</sub> = 3.0V, T<sub>A</sub> = 25°C

Symbol	Description	Min.	Typ.	Max.	Units	Conditions
V <sub>DD</sub>	Supply Voltage	1.8	—	5.5	V	
V <sub>OUT</sub>	Output Voltage Range	GND	—	V <sub>DD</sub>		
V <sub>LSB</sub>	Resolution	—	10	—	Bit	
V <sub>ACC</sub>	Absolute Accuracy	—	1	—	LSB	

.....continued

V<sub>DD</sub> = 3.0V, T<sub>A</sub> = 25°C

Symbol	Description	Min.	Typ.	Max.	Units	Conditions
t <sub>ST</sub>	Settling Time <sup>(1)</sup>	—	7	—	μs	V <sub>DD</sub> = 3.0V V <sub>DACREF</sub> = V <sub>DD</sub>
		—	10	—	μs	V <sub>DD</sub> = 5.5V V <sub>DACREF</sub> = V <sub>DD</sub>
INL	Integral Nonlinearity	—	1	—	LSb	
DNL	Differential Nonlinearity	—	0.2	—	LSb	
EOFF	Offset Error	—	0.55	—	LSb	
EGAIN	Gain Error	—	2.8	—	LSb	

**Note:**

- Settling time measured while DACR[9:0] transitions from '0x000' to '0x3FF'.

### 37.5.8 ADC Accuracy Specifications<sup>(1)</sup>

Table 37-23. ADC Accuracy Specifications

V<sub>DD</sub> = 3.0 V, T<sub>A</sub> = 25°C

Symbol	Description	Min.	Typ.	Max.	Units	Conditions
NR	Resolution	—	—	12	bit	
E <sub>INL</sub>	Integral Nonlinearity Error	—	0.1	—	LSb	
E <sub>DNL</sub>	Differential Nonlinearity Error	—	0.1	—	LSb	
E <sub>OFF</sub>	Offset Error	—	1.25	—	LSb	
E <sub>GAIN</sub>	Gain Error	—	2.5	—	LSb	
E <sub>ABS</sub>	Absolute Error	—	4	—	LSb	
V <sub>ADCREf</sub>	ADC Reference Voltage	1.8	—	V <sub>DD</sub>	V	
V <sub>AIN</sub>	ADC Input Pin Voltage	GND	—	V <sub>ADCREf</sub>	V	
Z <sub>AIN</sub>	Recommended Impedance of Analog Voltage Source	—	10	—	kΩ	
R <sub>VREFA</sub>	ADC Voltage Reference Ladder Impedance <sup>(2)</sup>	—	50	—	kΩ	

**Notes:**

- The ADC conversion result never decreases with an increase in the input and has no missing codes.
- This is the impedance seen by the VREFA pin when the external reference is selected.

### 37.5.9 ADC Conversion Timing Specifications

Table 37-24. ADC Conversion Timing Specifications

Symbol	Description	Min.	Typ.	Max.	Units	Conditions
T <sub>CLK_ADC</sub>	ADC Clock Period	0.5	—	8	μs	
t <sub>CNV</sub>	Conversion Time	—	13.5T <sub>CLK_ADC</sub> + 2T <sub>CLK_PER</sub>	—	—	
t <sub>ACQ</sub>	Acquisition Time	—	2T <sub>CLK_ADC</sub>	—	μs	

.....continued

Symbol	Description	Min.	Typ.	Max.	Units	Conditions
f <sub>ADC</sub>	Sample Rate	8	—	130	ksps	
t <sub>s</sub>	Sampling Time	—	2T <sub>CLK_ADC</sub>	—	—	

37.5.10 Analog Comparator Specifications

Table 37-25. Analog Comparator Specifications

V<sub>DD</sub> = 3.0V, T<sub>A</sub> = 25°C

Symbol	Description	Min.	Typ.	Max.	Unit	Condition
V <sub>IN</sub>	Input voltage range	0.1	—	V <sub>DD</sub> - 0.1	V	
I <sub>L</sub>	Input leakage current	—	5	—	nA	
V <sub>OFF</sub>	Input offset voltage	—	±5	—	mV	0.7V < V <sub>IN</sub> < (V <sub>DD</sub> -0.7V)
		—	±20	—		0.1V < V <sub>IN</sub> < (V <sub>DD</sub> - 0.1V)
CMRR	Common Mode Input Rejection Ratio	—	—	—	dB	
V <sub>HYST</sub>	Hysteresis	—	10	—	mV	HYSMODE = 0x1
		—	25	—		HYSMODE = 0x2
		—	50	—		HYSMODE = 0x3
t <sub>RESP</sub>	Response Time, Rising Edge	—	50	—	ns	Power Profile 0
	Response Time, Falling Edge	—	50	—		
	Response Time, Rising Edge	—	200	—	ns	Power Profile 1
	Response Time, Falling Edge	—	250	—		
	Response Time, Rising Edge	—	400	—	ns	Power Profile 2
	Response Time, Falling Edge	—	480	—		

37.5.11 PTC

Table 37-26. Peripheral Touch Controller Characteristics - Operating Ratings

V<sub>DD</sub> = 3.0 V, T<sub>A</sub> = 25°C

Symbol	Description	Condition	Min.	Typ.	Max.	Unit
C <sub>LOAD</sub>	Maximum load		—		31	pF
CLK <sub>PTC_ADC</sub>	PTC ADC operating frequency		250	—	2000	kHz

37.5.12 Zero-Cross Detector Specifications

Table 37-27. Zero-Cross Detector Specifications

V<sub>DD</sub> = 3.0V, T<sub>A</sub> = 25°C

Symbol	Description	Min.	Typ.	Max.	Units	Conditions
V <sub>PINZC</sub>	Voltage on ZCD Pin	—	0.9	—	V	
I <sub>ZCD_MAX</sub>	Maximum source or sink current	—	—	600	µA	

.....continued

$V_{DD} = 3.0V, T_A = 25^{\circ}C$

Symbol	Description	Min.	Typ.	Max.	Units	Conditions
tRESPH	Response Time, Rising Edge	—	1	—	μs	
tRESPL	Response Time, Falling Edge	—	1	—	μs	

### 37.5.13 UPDI Timing

Figure 37-10. UPDI Enable Sequence with Dedicated UPDI Pin

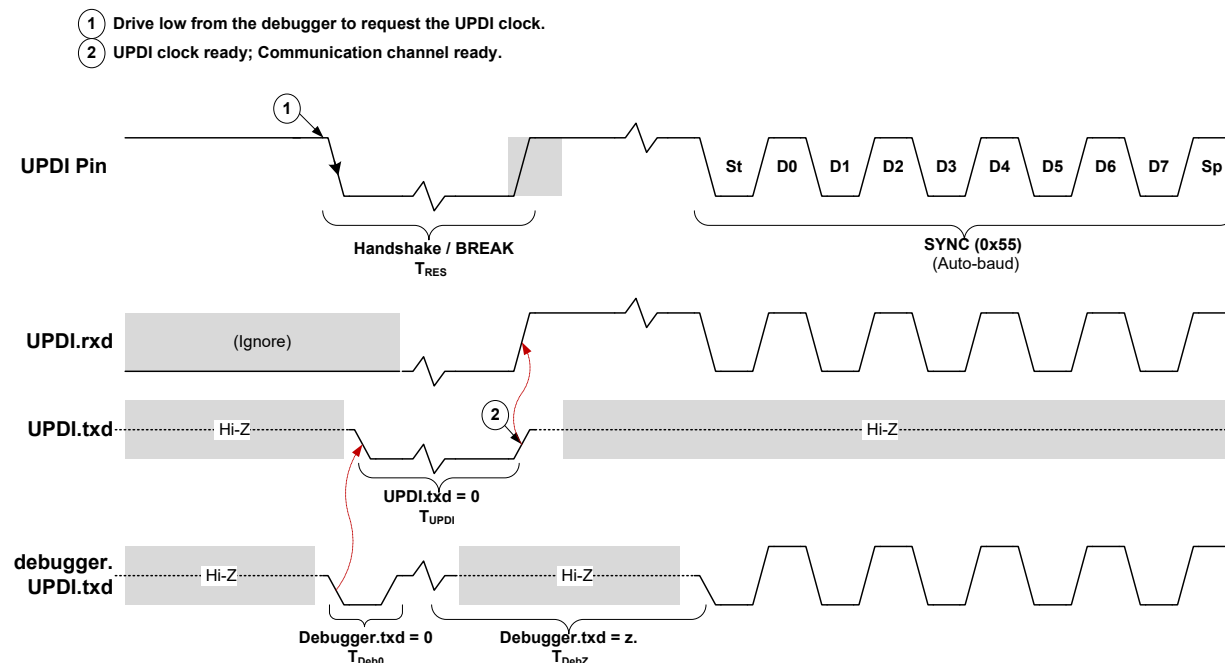


Table 37-28. UPDI Timing Characteristics

Symbol	Description	Min.	Max.	Unit
tRES	Duration of Handshake/Break on $\overline{RESET}$	10	200	μs
tUPDI	Duration of UPDI.txd = 0	10	200	μs
tDeb0	Duration of Debugger.txd = 0	0.2	1	μs
tDebZ	Duration of Debugger.txd = z	200	14000	μs

**38. Typical Characteristics**

Typical Characteristics are not available at this time.

## 39. Ordering Information

- Available ordering options can be found by:
  - Clicking on one of the following product page links:
    - [AVR128DA64 Product Page](#)
    - [AVR128DA48 Product Page](#)
    - [AVR128DA32 Product Page](#)
    - [AVR128DA28 Product Page](#)
  - Searching by product name at [microchipdirect.com](http://microchipdirect.com)
  - Contacting your local sales representative

**Table 39-1. Available Product Numbers**

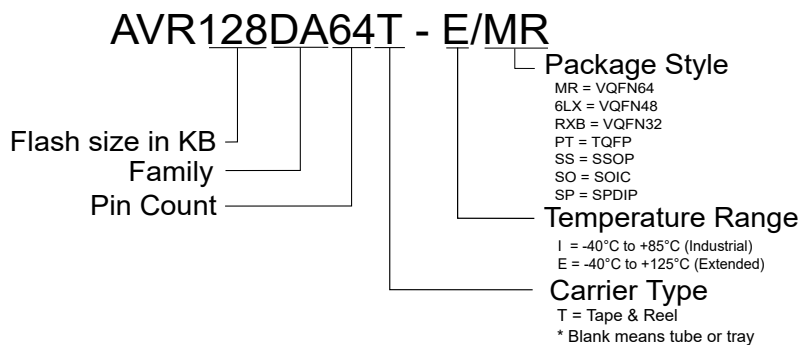
Ordering Code	Flash/SRAM	Pin Count	Package Type	Supply voltage	Temperature Range	Carrier Type
AVR128DA64T-E/MR	128 KB/16 KB	64	VQFN	1.8-5.5V	-40°C to +125°C	Tape & Reel
AVR128DA64T-E/PT	128 KB/16 KB	64	TQFP	1.8-5.5V	-40°C to +125°C	Tape & Reel
AVR128DA48T-E/6LX	128 KB/16 KB	48	VQFN	1.8-5.5V	-40°C to +125°C	Tape & Reel
AVR128DA48T-E/PT	128 KB/16 KB	48	TQFP	1.8-5.5V	-40°C to +125°C	Tape & Reel
AVR128DA32T-E/RXB	128 KB/16 KB	32	VQFN	1.8-5.5V	-40°C to +125°C	Tape & Reel
AVR128DA32T-E/PT	128 KB/16 KB	32	TQFP	1.8-5.5V	-40°C to +125°C	Tape & Reel
AVR128DA28T-E/SS	128 KB/16 KB	28	SSOP	1.8-5.5V	-40°C to +125°C	Tape & Reel
AVR128DA28T-E/SO	128 KB/16 KB	28	SOIC	1.8-5.5V	-40°C to +125°C	Tape & Reel
AVR128DA64T-I/MR	128 KB/16 KB	64	VQFN	1.8-5.5V	-40°C to +85°C	Tape & Reel
AVR128DA64T-I/PT	128 KB/16 KB	64	TQFP	1.8-5.5V	-40°C to +85°C	Tape & Reel
AVR128DA48T-I/6LX	128 KB/16 KB	48	VQFN	1.8-5.5V	-40°C to +85°C	Tape & Reel
AVR128DA48T-I/PT	128 KB/16 KB	48	TQFP	1.8-5.5V	-40°C to +85°C	Tape & Reel
AVR128DA32T-I/RXB	128 KB/16 KB	32	VQFN	1.8-5.5V	-40°C to +85°C	Tape & Reel
AVR128DA32T-I/PT	128 KB/16 KB	32	TQFP	1.8-5.5V	-40°C to +85°C	Tape & Reel
AVR128DA28T-I/SS	128 KB/16 KB	28	SSOP	1.8-5.5V	-40°C to +85°C	Tape & Reel
AVR128DA28T-I/SO	128 KB/16 KB	28	SOIC	1.8-5.5V	-40°C to +85°C	Tape & Reel
AVR128DA64-E/MR	128 KB/16 KB	64	VQFN	1.8-5.5V	-40°C to +125°C	Tray
AVR128DA64-E/PT	128 KB/16 KB	64	TQFP	1.8-5.5V	-40°C to +125°C	Tray
AVR128DA48-E/6LX	128 KB/16 KB	48	VQFN	1.8-5.5V	-40°C to +125°C	Tray
AVR128DA48-E/PT	128 KB/16 KB	48	TQFP	1.8-5.5V	-40°C to +125°C	Tray
AVR128DA32-E/RXB	128 KB/16 KB	32	VQFN	1.8-5.5V	-40°C to +125°C	Tray
AVR128DA32-E/PT	128 KB/16 KB	32	TQFP	1.8-5.5V	-40°C to +125°C	Tray
AVR128DA28-E/SS	128 KB/16 KB	28	SSOP	1.8-5.5V	-40°C to +125°C	Tube

.....continued

Ordering Code	Flash/SRAM	Pin Count	Package Type	Supply voltage	Temperature Range	Carrier Type
AVR128DA28-E/SO	128 KB/16 KB	28	SOIC	1.8-5.5V	-40°C to +125°C	Tube
AVR128DA28-E/SP	128 KB/16 KB	28	SPDIP	1.8-5.5V	-40°C to +125°C	Tube
AVR128DA64-I/MR	128 KB/16 KB	64	VQFN	1.8-5.5V	-40°C to +85°C	Tray
AVR128DA64-I/PT	128 KB/16 KB	64	TQFP	1.8-5.5V	-40°C to +85°C	Tray
AVR128DA48-I/6LX	128 KB/16 KB	48	VQFN	1.8-5.5V	-40°C to +85°C	Tray
AVR128DA48-I/PT	128 KB/16 KB	48	TQFP	1.8-5.5V	-40°C to +85°C	Tray
AVR128DA32-I/RXB	128 KB/16 KB	32	VQFN	1.8-5.5V	-40°C to +85°C	Tray
AVR128DA32-I/PT	128 KB/16 KB	32	TQFP	1.8-5.5V	-40°C to +85°C	Tray
AVR128DA28-I/SS	128 KB/16 KB	28	SSOP	1.8-5.5V	-40°C to +85°C	Tube
AVR128DA28-I/SO	128 KB/16 KB	28	SOIC	1.8-5.5V	-40°C to +85°C	Tube
AVR128DA28-I/SP	128 KB/16 KB	28	SPDIP	1.8-5.5V	-40°C to +85°C	Tube

**Figure 39-1. Product Identification System**

To order or obtain information, for example on pricing or delivery, refer to the factory, or the listed sales office.



**Note:** The Tape and Reel identifier only appears in the catalog part number description. This identifier is used for ordering purposes and is not printed on the device package. Check with your [Microchip Sales Office](#) for package availability with the Tape and Reel option.

## 40. Package Drawings

### 40.1 Online Package Drawings

For the most recent package drawings:

1. Go to [www.microchip.com/packaging](http://www.microchip.com/packaging).
2. Go to the package type-specific page, for example, VQFN.
3. Search for either Drawing Number or Style to find the most recent package drawings.

**Table 40-1. Drawing Numbers**

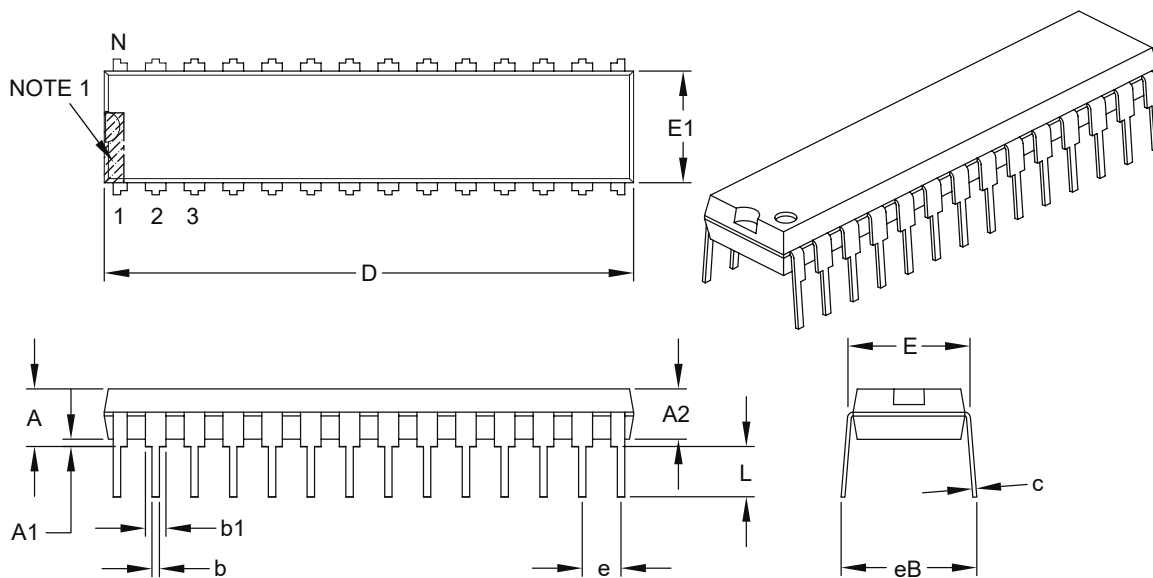
Pin Count	Package Type	Drawing Number	Style
28	SPDIP	C04-00070	SP
28	SOIC	C04-00052	SO
28	SSOP	C04-00073	SS
32	VQFN	C04-21395	RXB
32	TQFP	C04-00074	PT
48	VQFN	C04-00494	6LX
48	TQFP	C04-00300	PT
64	VQFN	C04-00149	MR
64	TQFP	C04-00085	PT



40.2 28-Pin SPDIP

28-Lead Skinny Plastic Dual In-Line (SP) – 300 mil Body [SPDIP]

**Note:** For the most current package drawings, please see the Microchip Packaging Specification located at <http://www.microchip.com/packaging>



Dimension Limits	Units	INCHES		
		MIN	NOM	MAX
Number of Pins	N	28		
Pitch	e	.100 BSC		
Top to Seating Plane	A	–	–	.200
Molded Package Thickness	A2	.120	.135	.150
Base to Seating Plane	A1	.015	–	–
Shoulder to Shoulder Width	E	.290	.310	.335
Molded Package Width	E1	.240	.285	.295
Overall Length	D	1.345	1.365	1.400
Tip to Seating Plane	L	.110	.130	.150
Lead Thickness	c	.008	.010	.015
Upper Lead Width	b1	.040	.050	.070
Lower Lead Width	b	.014	.018	.022
Overall Row Spacing §	eB	–	–	.430

**Notes:**

1. Pin 1 visual index feature may vary, but must be located within the hatched area.
2. § Significant Characteristic.
3. Dimensions D and E1 do not include mold flash or protrusions. Mold flash or protrusions shall not exceed .010" per side.
4. Dimensioning and tolerancing per ASME Y14.5M.

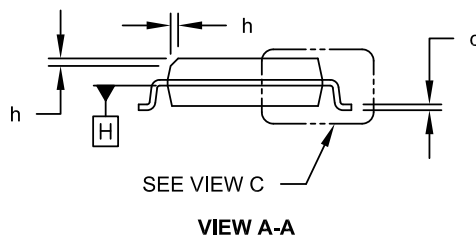
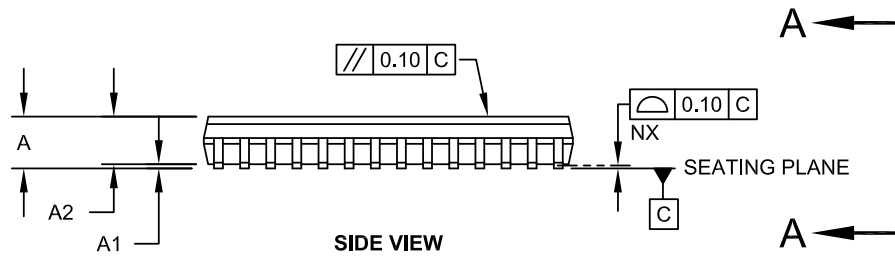
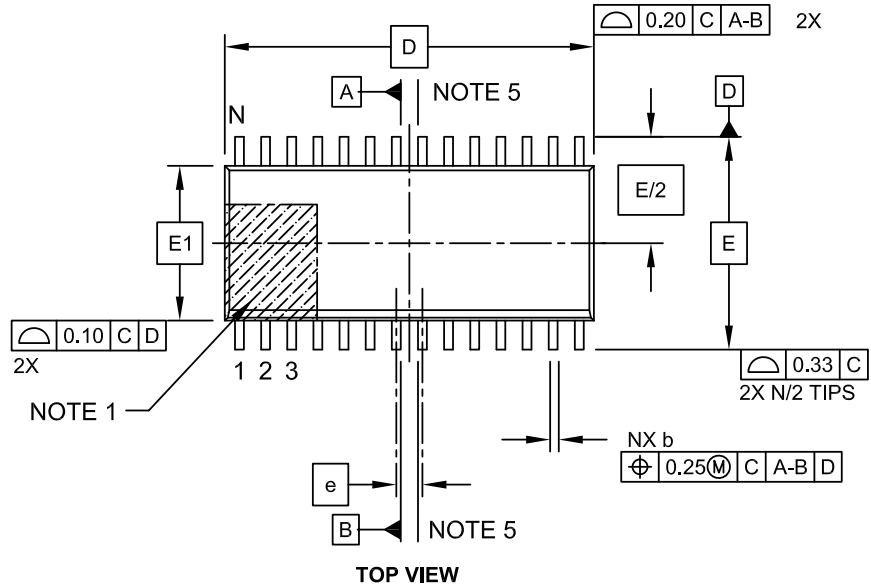
BSC: Basic Dimension. Theoretically exact value shown without tolerances.

Microchip Technology Drawing C04-070B

40.3 28-Pin SOIC

28-Lead Plastic Small Outline (SO) - Wide, 7.5 mm Body [SOIC]

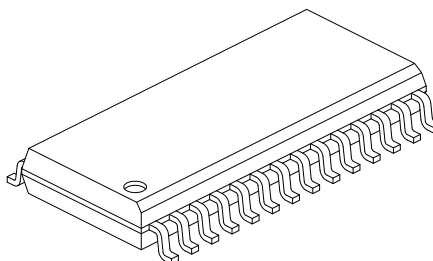
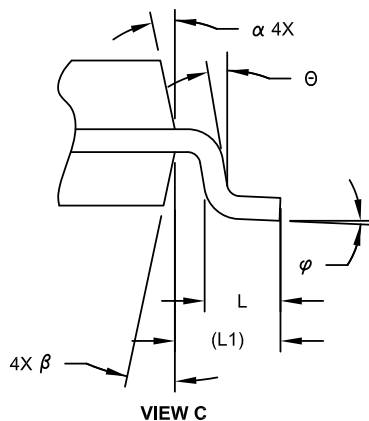
**Note:** For the most current package drawings, please see the Microchip Packaging Specification located at <http://www.microchip.com/packaging>



Microchip Technology Drawing C04-052C Sheet 1 of 2

### 28-Lead Plastic Small Outline (SO) - Wide, 7.50 mm Body [SOIC]

**Note:** For the most current package drawings, please see the Microchip Packaging Specification located at <http://www.microchip.com/packaging>



		Units	MILLIMETERS		
Dimension Limits			MIN	NOM	MAX
Number of Pins	N		28		
Pitch	e		1.27 BSC		
Overall Height	A	-	-	-	2.65
Molded Package Thickness	A2		2.05	-	-
Standoff §	A1		0.10	-	0.30
Overall Width	E		10.30 BSC		
Molded Package Width	E1		7.50 BSC		
Overall Length	D		17.90 BSC		
Chamfer (Optional)	h		0.25	-	0.75
Foot Length	L		0.40	-	1.27
Footprint	L1		1.40 REF		
Lead Angle	θ		0°	-	-
Foot Angle	φ		0°	-	8°
Lead Thickness	c		0.18	-	0.33
Lead Width	b		0.31	-	0.51
Mold Draft Angle Top	α		5°	-	15°
Mold Draft Angle Bottom	β		5°	-	15°

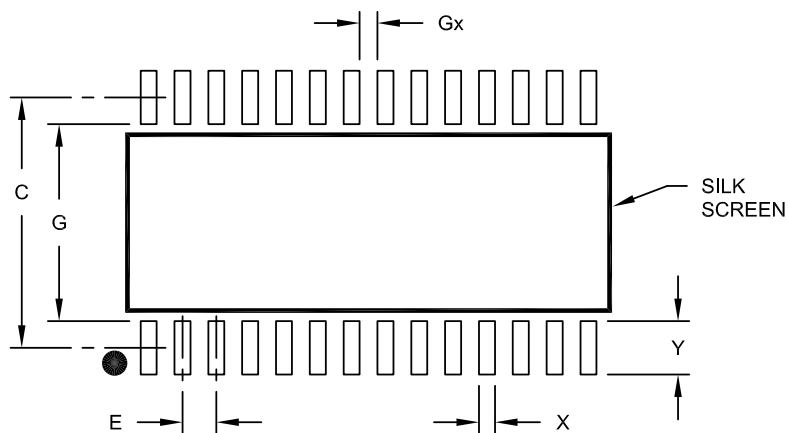
**Notes:**

- Pin 1 visual index feature may vary, but must be located within the hatched area.
- § Significant Characteristic
- Dimension D does not include mold flash, protrusions or gate burrs, which shall not exceed 0.15 mm per end. Dimension E1 does not include interlead flash or protrusion, which shall not exceed 0.25 mm per side.
- Dimensioning and tolerancing per ASME Y14.5M  
 BSC: Basic Dimension. Theoretically exact value shown without tolerances.  
 REF: Reference Dimension, usually without tolerance, for information purposes only.
- Datums A & B to be determined at Datum H.

Microchip Technology Drawing C04-052C Sheet 2 of 2

### 28-Lead Plastic Small Outline (SO) - Wide, 7.50 mm Body [SOIC]

**Note:** For the most current package drawings, please see the Microchip Packaging Specification located at <http://www.microchip.com/packaging>



### RECOMMENDED LAND PATTERN

Dimension Limits	Units	MILLIMETERS		
		MIN	NOM	MAX
Contact Pitch	E	1.27 BSC		
Contact Pad Spacing	C		9.40	
Contact Pad Width (X28)	X			0.60
Contact Pad Length (X28)	Y			2.00
Distance Between Pads	Gx	0.67		
Distance Between Pads	G	7.40		

**Notes:**

1. Dimensioning and tolerancing per ASME Y14.5M

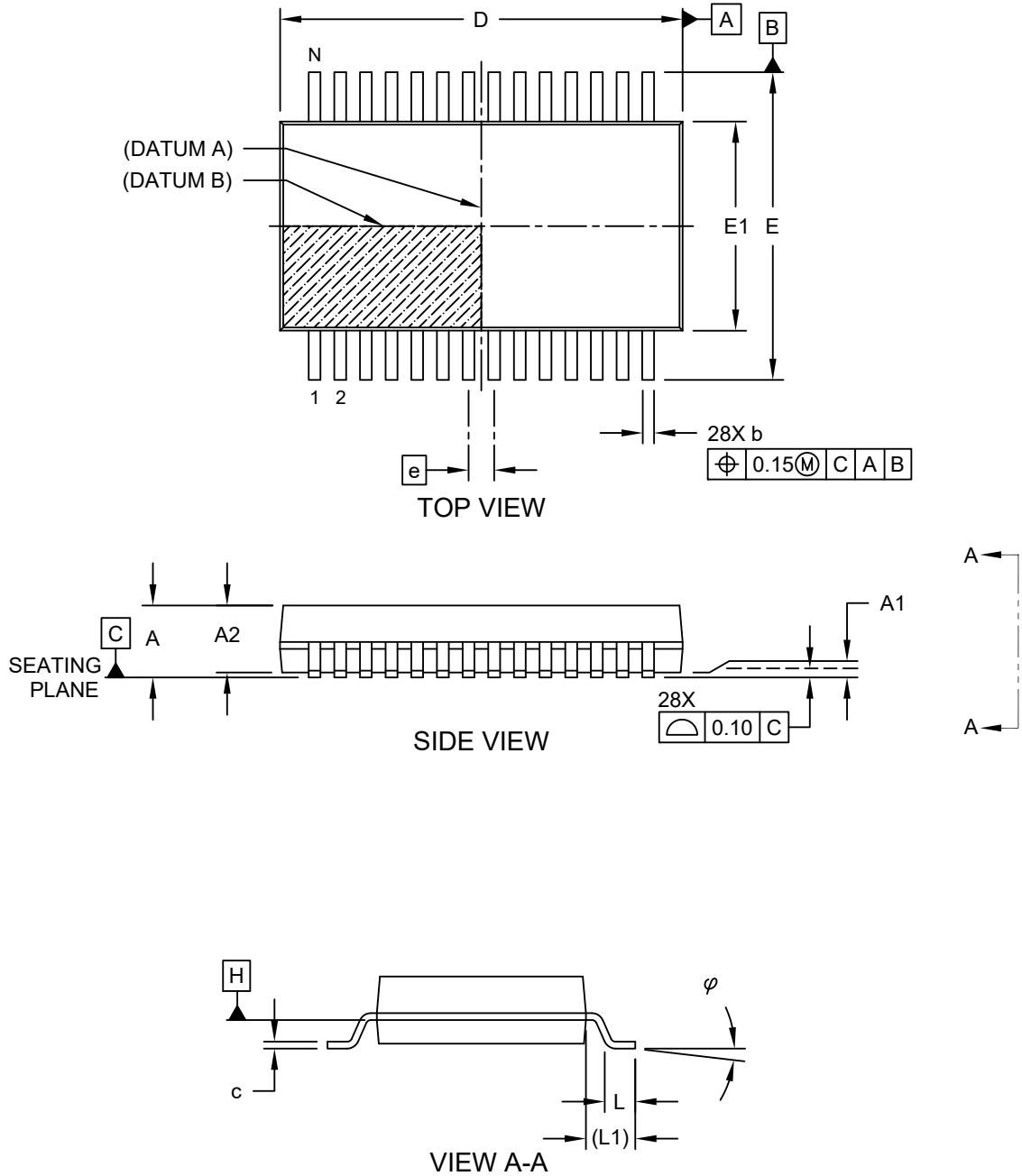
BSC: Basic Dimension. Theoretically exact value shown without tolerances.

Microchip Technology Drawing No. C04-2052A

40.4 28-Pin SSOP

28-Lead Plastic Shrink Small Outline (SS) - 5.30 mm Body [SSOP]

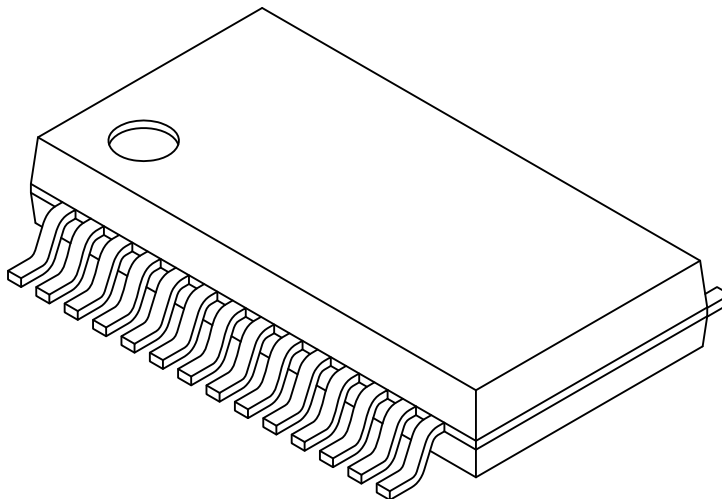
**Note:** For the most current package drawings, please see the Microchip Packaging Specification located at <http://www.microchip.com/packaging>



Microchip Technology Drawing C04-073 Rev C Sheet 1 of 2

**28-Lead Plastic Shrink Small Outline (SS) - 5.30 mm Body [SSOP]**

**Note:** For the most current package drawings, please see the Microchip Packaging Specification located at <http://www.microchip.com/packaging>



Dimension Limits	Units	MILLIMETERS		
		MIN	NOM	MAX
Number of Pins	N	28		
Pitch	e	0.65 BSC		
Overall Height	A	-	-	2.00
Molded Package Thickness	A2	1.65	1.75	1.85
Standoff	A1	0.05	-	-
Overall Width	E	7.40	7.80	8.20
Molded Package Width	E1	5.00	5.30	5.60
Overall Length	D	9.90	10.20	10.50
Foot Length	L	0.55	0.75	0.95
Footprint	L1	1.25 REF		
Lead Thickness	c	0.09	-	0.25
Foot Angle	$\varphi$	0°	4°	8°
Lead Width	b	0.22	-	0.38

**Notes:**

- Pin 1 visual index feature may vary, but must be located within the hatched area.
- Dimensions D and E1 do not include mold flash or protrusions. Mold flash or protrusions shall not exceed 0.20mm per side.
- Dimensioning and tolerancing per ASME Y14.5M

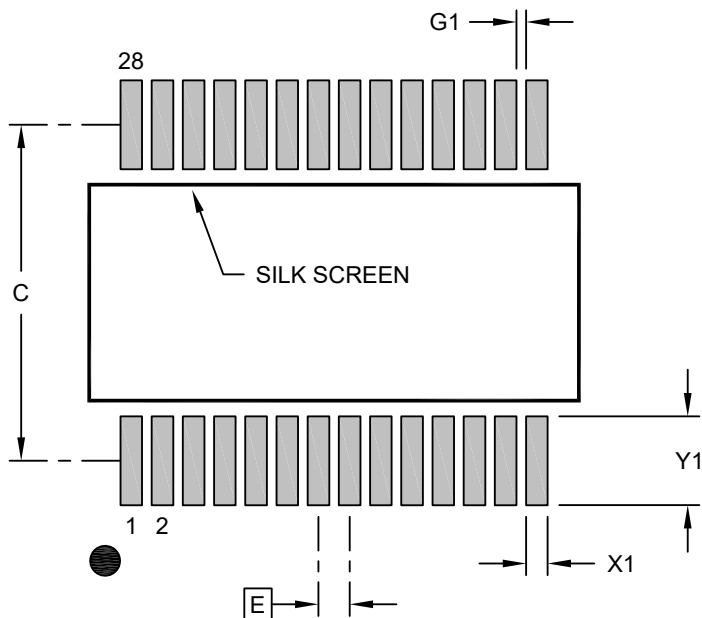
BSC: Basic Dimension. Theoretically exact value shown without tolerances.

REF: Reference Dimension, usually without tolerance, for information purposes only.

Microchip Technology Drawing C04-073 Rev C Sheet 2 of 2

### 28-Lead Plastic Shrink Small Outline (SS) - 5.30 mm Body [SSOP]

**Note:** For the most current package drawings, please see the Microchip Packaging Specification located at <http://www.microchip.com/packaging>



#### RECOMMENDED LAND PATTERN

Dimension Limits	Units	MILLIMETERS		
		MIN	NOM	MAX
Contact Pitch	E	0.65 BSC		
Contact Pad Spacing	C		7.00	
Contact Pad Width (X28)	X1			0.45
Contact Pad Length (X28)	Y1			1.85
Contact Pad to Center Pad (X26)	G1	0.20		

**Notes:**

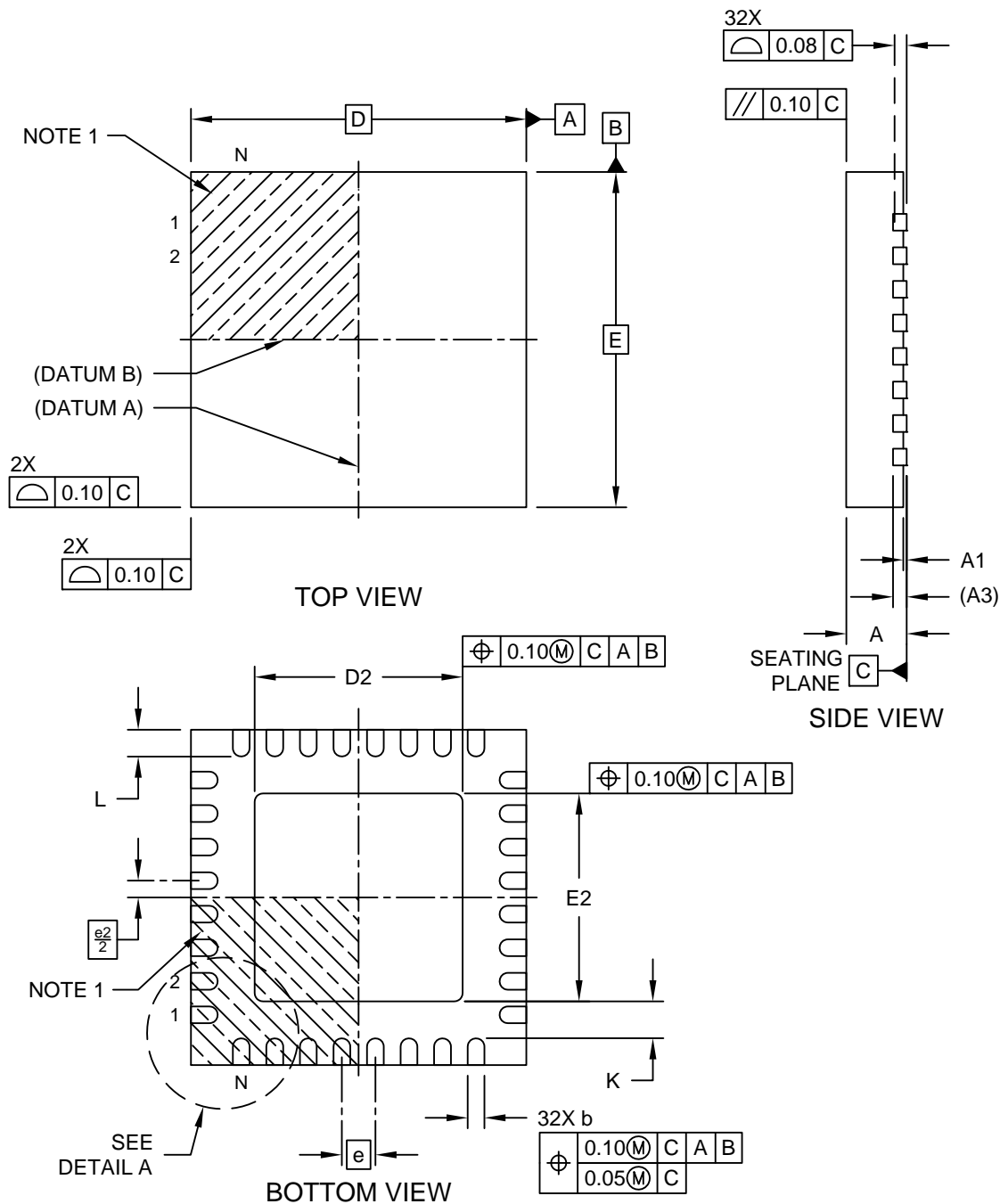
1. Dimensioning and tolerancing per ASME Y14.5M  
BSC: Basic Dimension. Theoretically exact value shown without tolerances.
2. For best soldering results, thermal vias, if used, should be filled or tented to avoid solder loss during reflow process

Microchip Technology Drawing C04-2073 Rev B

40.5 32-Pin VQFN

32-Lead Very Thin Plastic Quad Flat, No Lead Package (RXB) - 5x5x0.9 mm Body [VQFN] With 3.1x3.1 mm Exposed Pad; Atmel Legacy Global Package Code ZMF

**Note:** For the most current package drawings, please see the Microchip Packaging Specification located at <http://www.microchip.com/packaging>

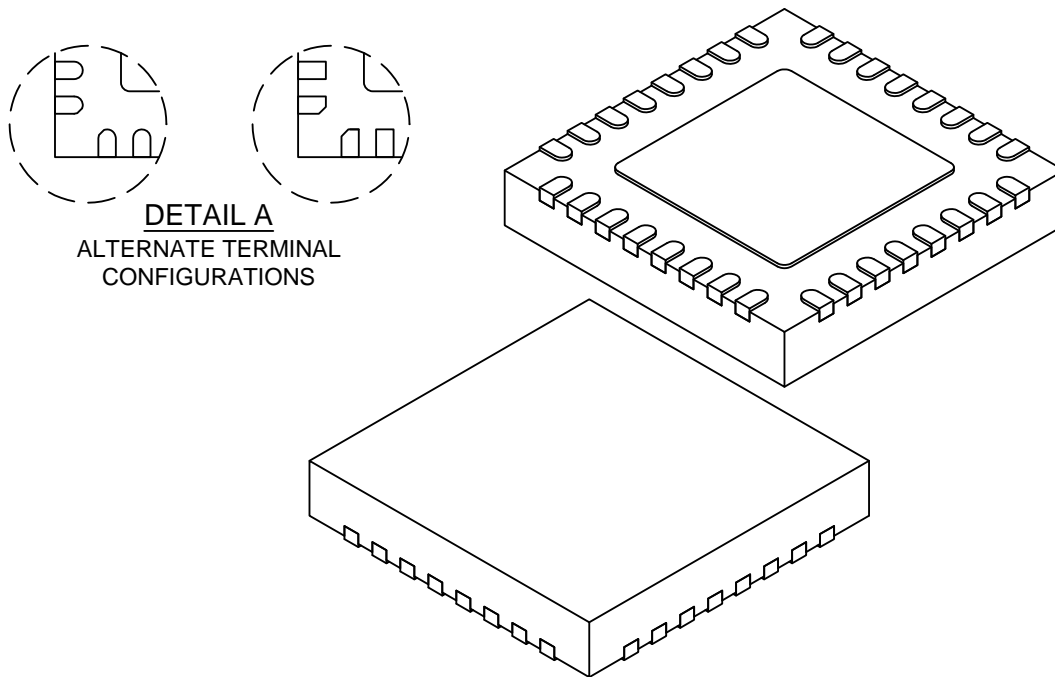


Microchip Technology Drawing C04-21395-RXB Rev B Sheet 1 of 2



### 32-Lead Very Thin Plastic Quad Flat, No Lead Package (RXB) - 5x5x0.9 mm Body [VQFN] With 3.1x3.1 mm Exposed Pad; Atmel Legacy Global Package Code ZMF

**Note:** For the most current package drawings, please see the Microchip Packaging Specification located at <http://www.microchip.com/packaging>



**DETAIL A**  
ALTERNATE TERMINAL  
CONFIGURATIONS

Dimension Limits	Units	MILLIMETERS		
		MIN	NOM	MAX
Number of Terminals	N	32		
Pitch	e	0.50 BSC		
Overall Height	A	0.80	0.85	0.90
Standoff	A1	0.00	0.02	0.05
Terminal Thickness	A3	0.203 REF		
Overall Length	D	5.00 BSC		
Exposed Pad Length	D2	3.00	3.10	3.20
Overall Width	E	5.00 BSC		
Exposed Pad Width	E2	3.00	3.10	3.20
Terminal Width	b	0.18	0.25	0.30
Terminal Length	L	0.30	0.40	0.50
Terminal-to-Exposed-Pad	K	0.20	-	-

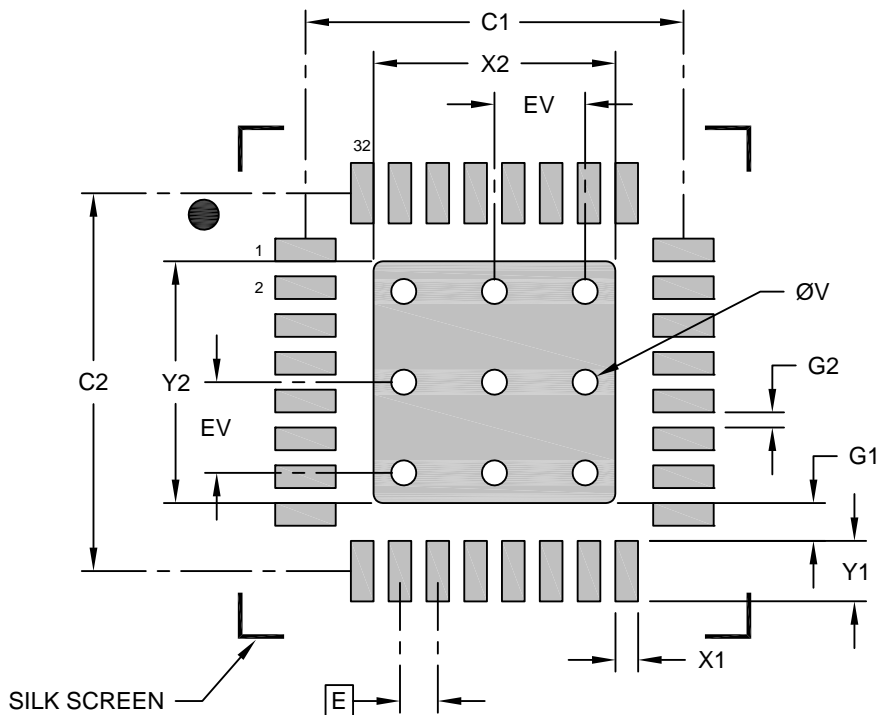
**Notes:**

- Pin 1 visual index feature may vary, but must be located within the hatched area.
- Package is saw singulated
- Dimensioning and tolerancing per ASME Y14.5M  
BSC: Basic Dimension. Theoretically exact value shown without tolerances.  
REF: Reference Dimension, usually without tolerance, for information purposes only.

Microchip Technology Drawing C04-21395-RXB Rev B Sheet 2 of 2

**32-Lead Very Thin Plastic Quad Flat, No Lead Package (RXB) - 5x5x0.9 mm Body [VQFN]  
With 3.1x3.1 mm Exposed Pad; Atmel Legacy Global Package Code ZMF**

**Note:** For the most current package drawings, please see the Microchip Packaging Specification located at <http://www.microchip.com/packaging>



**RECOMMENDED LAND PATTERN**

Dimension Limits	Units	MILLIMETERS		
		MIN	NOM	MAX
Contact Pitch	E	0.50 BSC		
Center Pad Width	X2			3.20
Center Pad Length	Y2			3.20
Contact Pad Spacing	C1		5.00	
Contact Pad Spacing	C2		5.00	
Contact Pad Width (X32)	X1			0.30
Contact Pad Length (X32)	Y1			0.80
Contact Pad to Center Pad (X32)	G1	0.20		
Contact Pad to Contact Pad (X28)	G2	0.20		
Thermal Via Diameter	V		0.33	
Thermal Via Pitch	EV		1.20	

**Notes:**

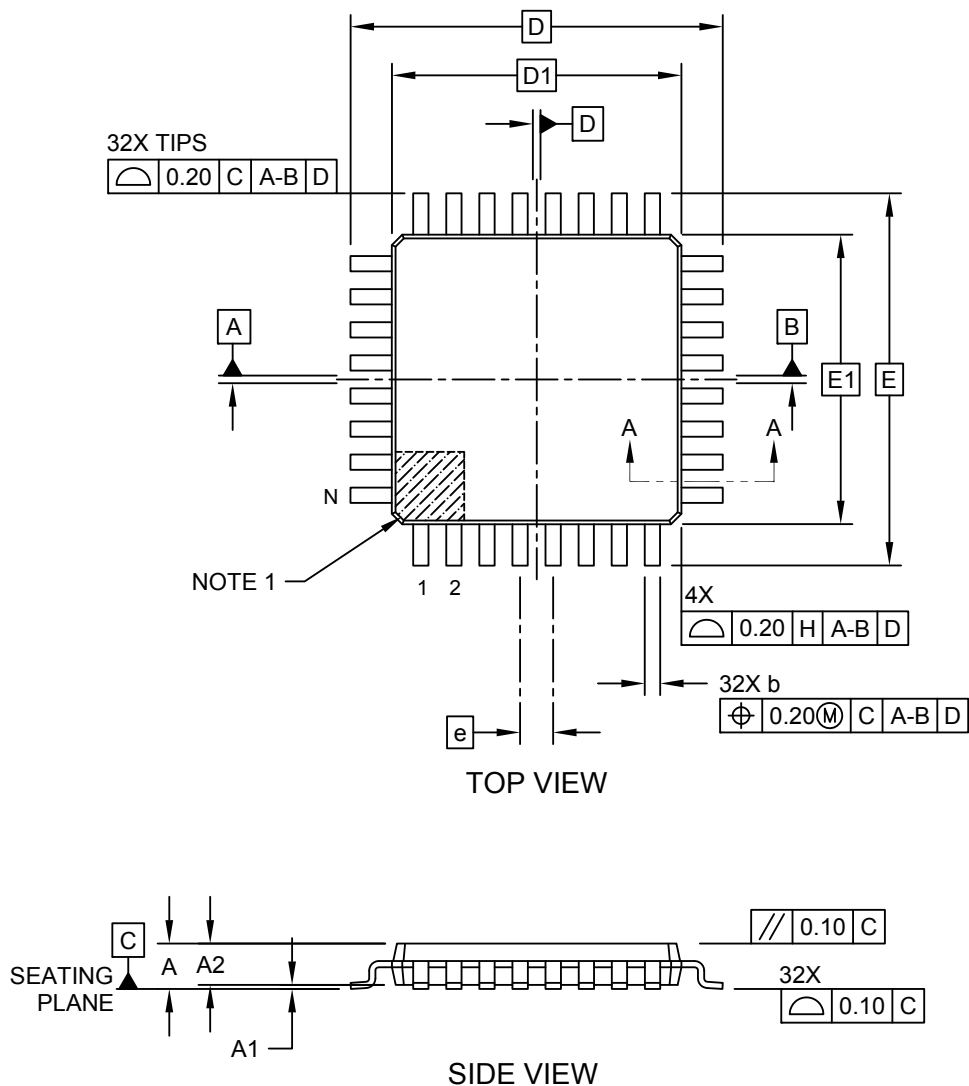
1. Dimensioning and tolerancing per ASME Y14.5M  
BSC: Basic Dimension. Theoretically exact value shown without tolerances.
2. For best soldering results, thermal vias, if used, should be filled or tented to avoid solder loss during reflow process

Microchip Technology Drawing C04-23395-RXB Rev B

40.6 32-Pin TQFP

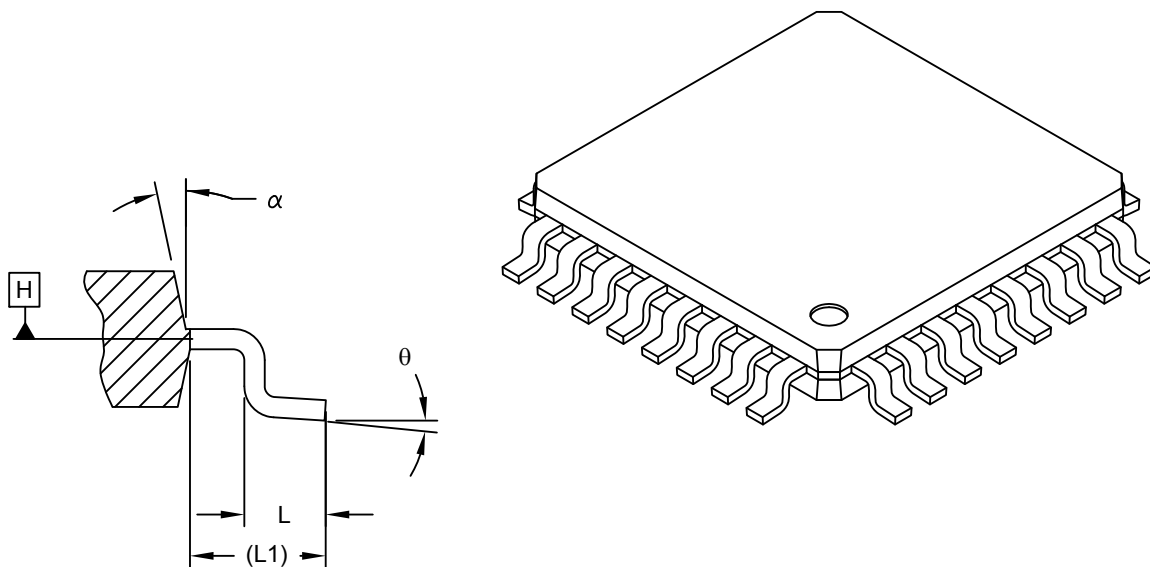
32-Lead Plastic Thin Quad Flatpack (PT) - 7x7x1.0 mm Body [TQFP]  
2.00 mm Footprint; Also Atmel Legacy Global Package Code AUT

**Note:** For the most current package drawings, please see the Microchip Packaging Specification located at <http://www.microchip.com/packaging>



**32-Lead Plastic Thin Quad Flatpack (PT) - 7x7x1.0 mm Body [TQFP]  
2.00 mm Footprint; Also Atmel Legacy Global Package Code AUT**

**Note:** For the most current package drawings, please see the Microchip Packaging Specification located at <http://www.microchip.com/packaging>



SECTION A-A

Dimension Limits	Units	MILLIMETERS		
		MIN	NOM	MAX
Number of Leads	N	32		
Lead Pitch	e	0.80 BSC		
Overall Height	A	-	-	1.20
Standoff	A1	0.05	-	0.15
Molded Package Thickness	A2	0.95	1.00	1.05
Foot Length	L	0.45	0.60	0.75
Footprint	L1	1.00 REF		
Foot Angle	$\theta$	0°	-	7°
Overall Width	E	9.00 BSC		
Overall Length	D	9.00 BSC		
Molded Package Width	E1	7.00 BSC		
Molded Package Length	D1	7.00 BSC		
Lead Width	b	0.30	0.37	0.45
Mold Draft Angle Top	$\alpha$	11°	-	13°

Notes:

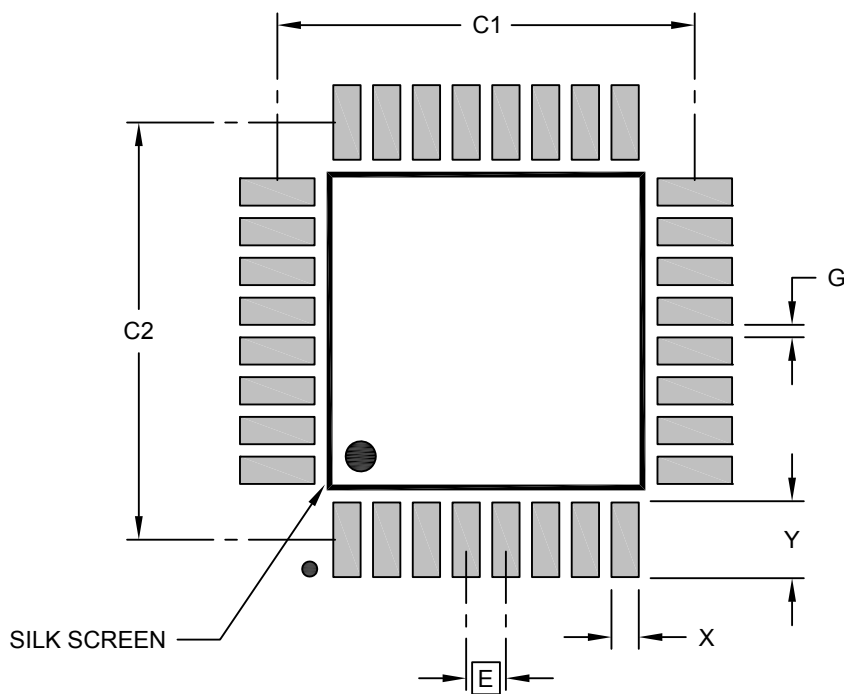
1. Pin 1 visual index feature may vary, but must be located within the hatched area.
2. Dimensioning and tolerancing per ASME Y14.5M

BSC: Basic Dimension. Theoretically exact value shown without tolerances.

REF: Reference Dimension, usually without tolerance, for information purposes only.

### 32-Lead Thin Plastic Quad Flatpack (PT) - 7x7 mm Body [TQFP] 2.00 mm Footprint; Also Atmel Legacy Global Package Code AUT

**Note:** For the most current package drawings, please see the Microchip Packaging Specification located at <http://www.microchip.com/packaging>



#### RECOMMENDED LAND PATTERN

Dimension Limits	Units	MILLIMETERS		
		MIN	NOM	MAX
Contact Pitch	E	0.80 BSC		
Contact Pad Spacing	C1		8.40	
Contact Pad Spacing	C2		8.40	
Contact Pad Width (Xnn)	X			0.55
Contact Pad Length (Xnn)	Y			1.55
Contact Pad to Contact Pad (Xnn)	G	0.25		

**Notes:**

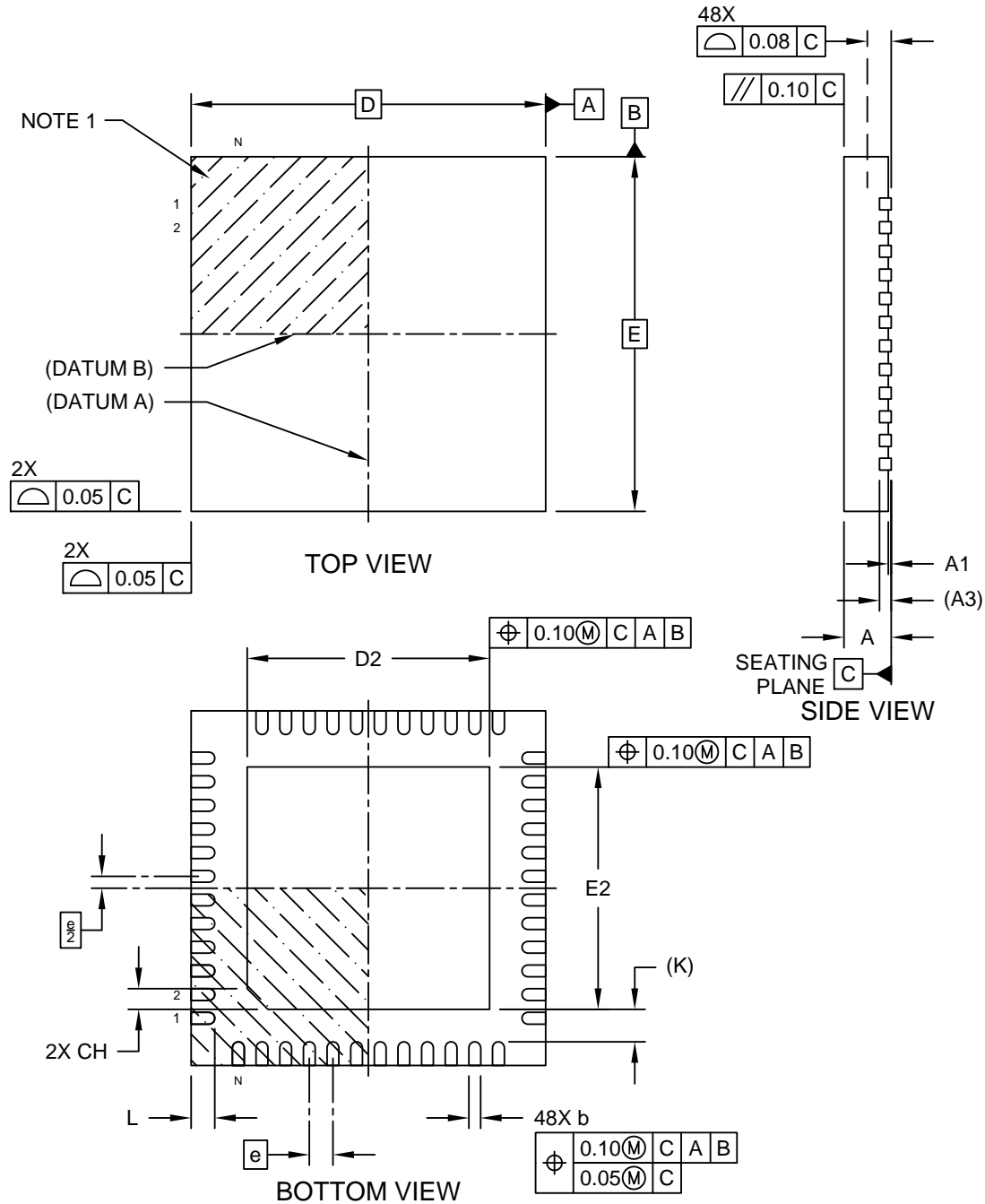
1. Dimensioning and tolerancing per ASME Y14.5M  
BSC: Basic Dimension. Theoretically exact value shown without tolerances.

Microchip Technology Drawing C04-2074 Rev C

40.7 48-Pin VQFN

48-Lead Very Thin Plastic Quad Flat, No Lead Package (6LX) - 6x6 mm Body [VQFN]  
With 4.1x4.1 mm Exposed Pad

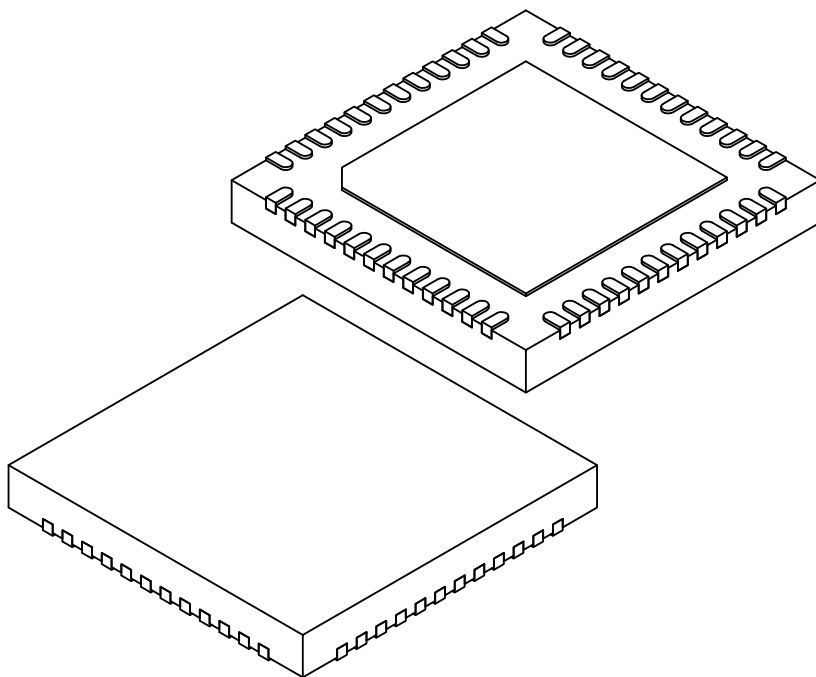
**Note:** For the most current package drawings, please see the Microchip Packaging Specification located at <http://www.microchip.com/packaging>



Microchip Technology Drawing C04-494 Rev A Sheet 1 of 2

### 48-Lead Very Thin Plastic Quad Flat, No Lead Package (6LX) - 6x6 mm Body [VQFN] With 4.1x4.1 mm Exposed Pad

**Note:** For the most current package drawings, please see the Microchip Packaging Specification located at <http://www.microchip.com/packaging>



Dimension Limits	Units	MILLIMETERS		
		MIN	NOM	MAX
Number of Terminals	N	48		
Pitch	e	0.40 BSC		
Overall Height	A	0.80	0.85	0.90
Standoff	A1	0.00	0.02	0.05
Terminal Thickness	A3	0.20 REF		
Overall Length	D	6.00 BSC		
Exposed Pad Length	D2	4.00	4.10	4.20
Overall Width	E	6.00 BSC		
Exposed Pad Width	E2	4.00	4.10	4.20
Exposed Pad Corner Chamfer	CH	0.35 REF		
Terminal Width	b	0.15	0.20	0.25
Terminal Length	L	0.30	0.40	0.50
Terminal-to-Exposed-Pad	K	0.55 REF		

**Notes:**

1. Pin 1 visual index feature may vary, but must be located within the hatched area.
2. Package is saw singulated
3. Dimensioning and tolerancing per ASME Y14.5M

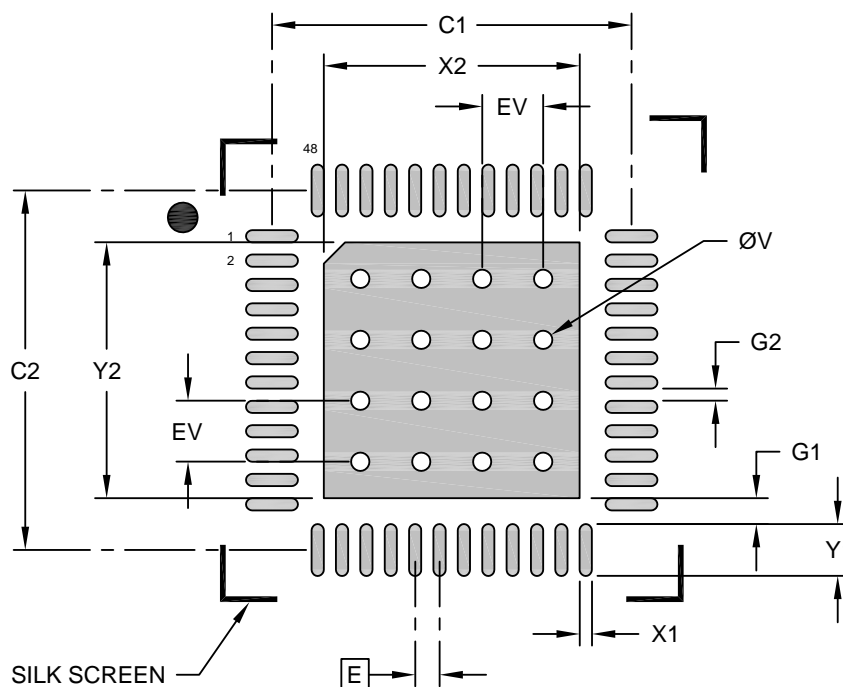
BSC: Basic Dimension. Theoretically exact value shown without tolerances.

REF: Reference Dimension, usually without tolerance, for information purposes only.

Microchip Technology Drawing C04-494 Rev A Sheet 1 of 2

**48-Lead Very Thin Plastic Quad Flat, No Lead (6LX) - 6x6 mm Body [VQFN]  
With 4.1x4.1 mm Exposed Pad**

**Note:** For the most current package drawings, please see the Microchip Packaging Specification located at <http://www.microchip.com/packaging>



**RECOMMENDED LAND PATTERN**

Dimension Limits	Units	MILLIMETERS		
		MIN	NOM	MAX
Contact Pitch	E	0.40 BSC		
Optional Center Pad Width	X2			4.20
Optional Center Pad Length	Y2			4.20
Contact Pad Spacing	C1		5.90	
Contact Pad Spacing	C2		5.90	
Contact Pad Width (X48)	X1			0.20
Contact Pad Length (X48)	Y1			0.85
Contact Pad to Center Pad (X48)	G1	0.20		
Contact Pad to Contact Pad (X44)	G2	0.20		
Thermal Via Diameter	V		0.30	
Thermal Via Pitch	EV		1.00	

**Notes:**

- Dimensioning and tolerancing per ASME Y14.5M  
BSC: Basic Dimension. Theoretically exact value shown without tolerances.
- For best soldering results, thermal vias, if used, should be filled or tented to avoid solder loss during reflow process

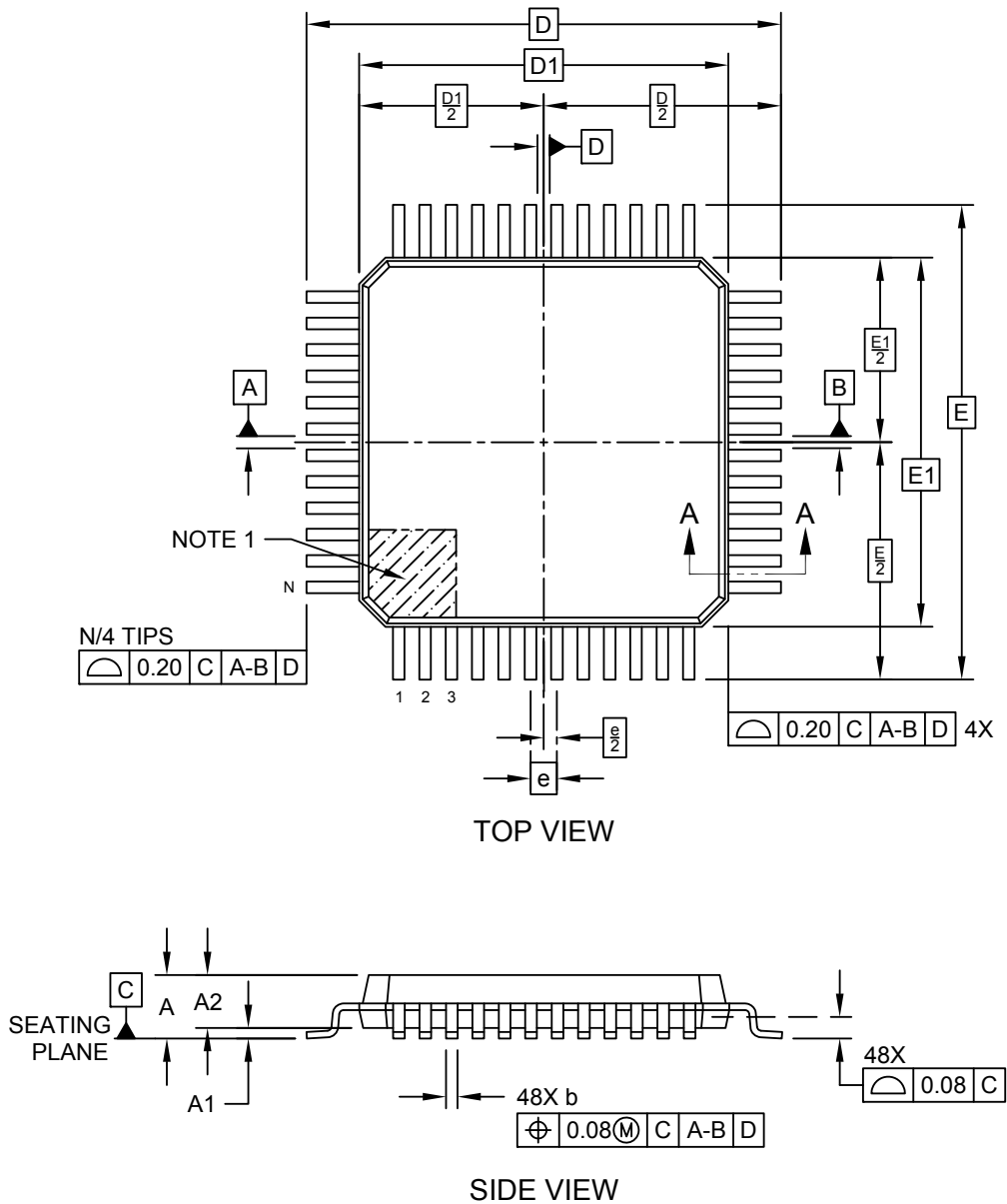
Microchip Technology Drawing C04-2494 Rev A



40.8 48-Pin TQFP

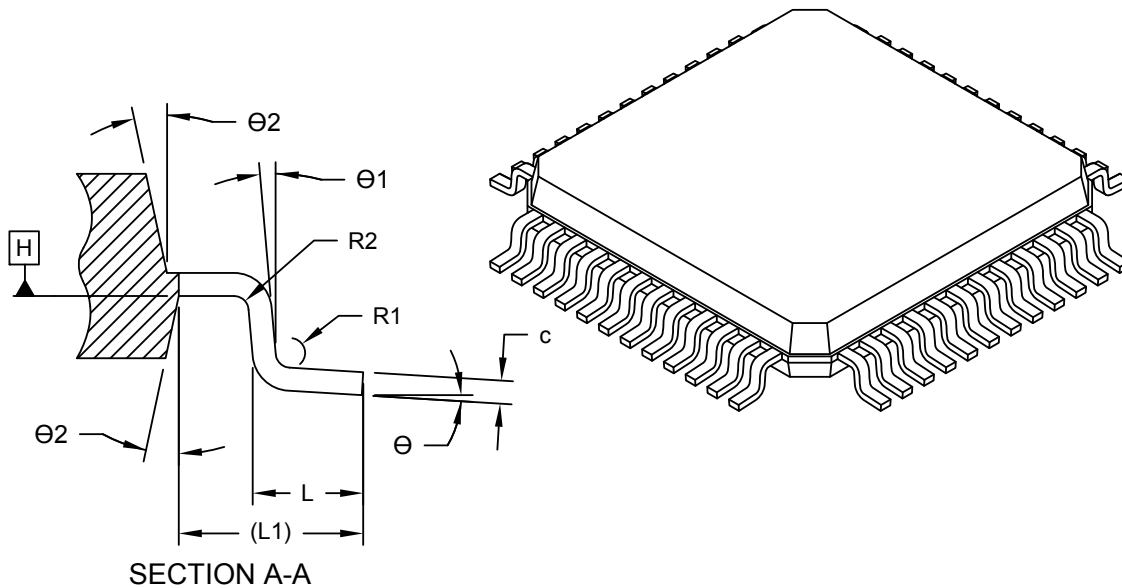
48-Lead Plastic Thin Quad Flatpack (PT) - 7x7x1.0 mm Body [TQFP]

**Note:** For the most current package drawings, please see the Microchip Packaging Specification located at <http://www.microchip.com/packaging>



### 48-Lead Plastic Thin Quad Flatpack (PT) - 7x7x1.0 mm Body [TQFP]

**Note:** For the most current package drawings, please see the Microchip Packaging Specification located at <http://www.microchip.com/packaging>



Dimension Limits	Units	MILLIMETERS		
		MIN	NOM	MAX
Number of Terminals	N	48		
Pitch	e	0.50 BSC		
Overall Height	A	-	-	1.20
Standoff	A1	0.05	-	0.15
Molded Package Thickness	A2	0.95	1.00	1.05
Overall Length	D	9.00 BSC		
Molded Package Length	D1	7.00 BSC		
Overall Width	E	9.00 BSC		
Molded Package Width	E1	7.00 BSC		
Terminal Width	b	0.17	0.22	0.27
Terminal Thickness	c	0.09	-	0.16
Terminal Length	L	0.45	0.60	0.75
Footprint	L1	1.00 REF		
Lead Bend Radius	R1	0.08	-	-
Lead Bend Radius	R2	0.08	-	0.20
Foot Angle	θ	0°	3.5°	7°
Lead Angle	θ1	0°	-	-
Mold Draft Angle	θ2	11°	12°	13°

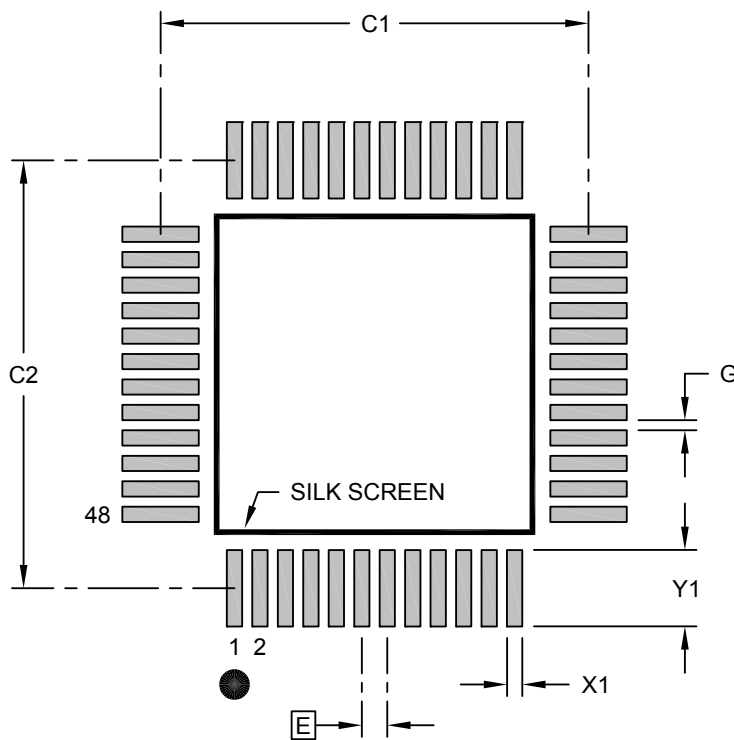
**Notes:**

1. Pin 1 visual index feature may vary, but must be located within the hatched area.
2. Dimensioning and tolerancing per ASME Y14.5M  
 BSC: Basic Dimension. Theoretically exact value shown without tolerances.  
 REF: Reference Dimension, usually without tolerance, for information purposes only.

Microchip Technology Drawing C04-300-PT Rev D Sheet 2 of 2

48-Lead Plastic Thin Quad Flatpack (PT) - 7x7x1.0 mm Body [TQFP]

**Note:** For the most current package drawings, please see the Microchip Packaging Specification located at <http://www.microchip.com/packaging>



RECOMMENDED LAND PATTERN

Dimension Limits	Units	MILLIMETERS		
		MIN	NOM	MAX
Contact Pitch	E	0.50 BSC		
Contact Pad Spacing	C1		8.40	
Contact Pad Spacing	C2		8.40	
Contact Pad Width (X48)	X1			0.30
Contact Pad Length (X48)	Y1			1.50
Distance Between Pads	G	0.20		

Notes:

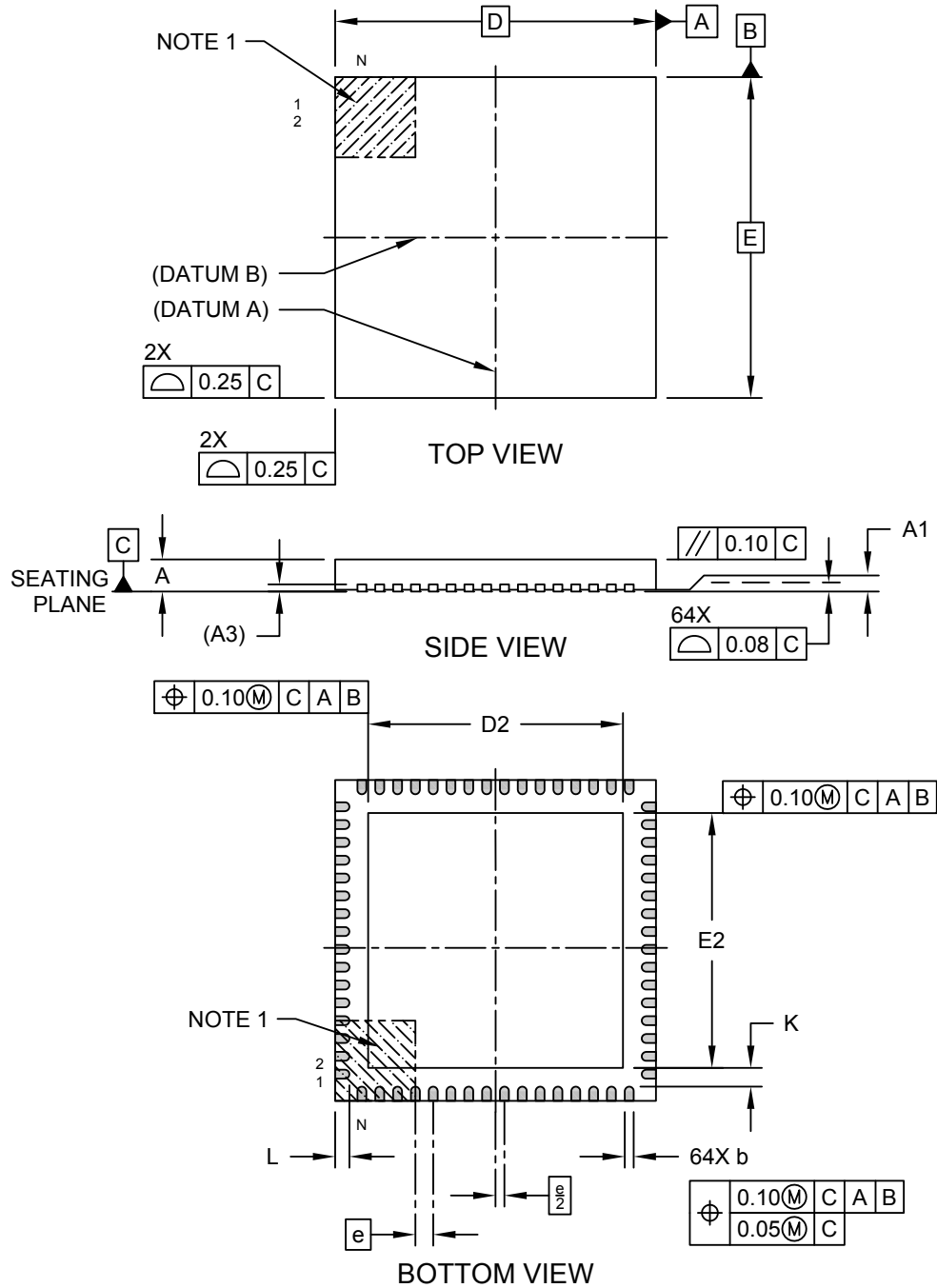
1. Dimensioning and tolerancing per ASME Y14.5M  
BSC: Basic Dimension. Theoretically exact value shown without tolerances.
2. For best soldering results, thermal vias, if used, should be filled or tented to avoid solder loss during reflow process

Microchip Technology Drawing C04-2300-PT Rev D

40.9 64-Pin VQFN

64-Lead Very Thin Plastic Quad Flat, No Lead Package (MR) – 9x9x0.9 mm Body [VQFN]  
With 7.15 x 7.15 Exposed Pad [Also called QFN]

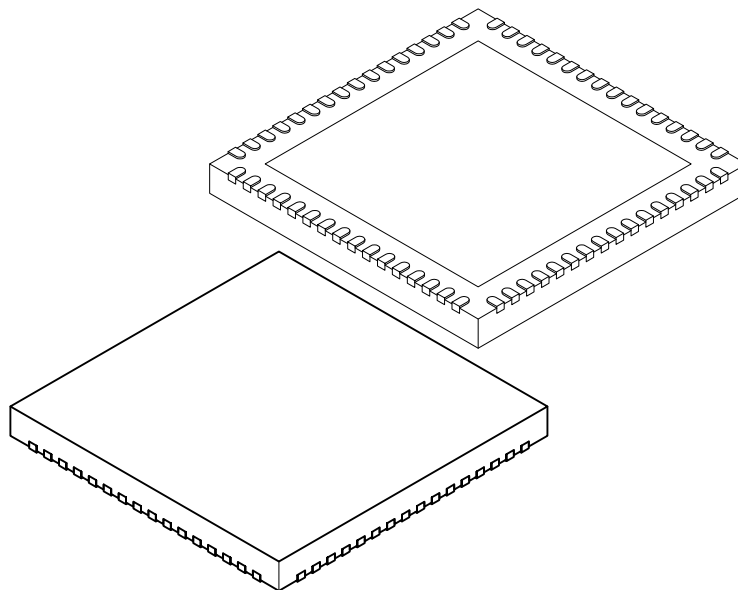
**Note:** For the most current package drawings, please see the Microchip Packaging Specification located at <http://www.microchip.com/packaging>



Microchip Technology Drawing C04-149 [MR] Rev E Sheet 1 of 2

### 64-Lead Very Thin Plastic Quad Flat, No Lead Package (MR) – 9x9x0.9 mm Body [VQFN] With 7.15 x 7.15 Exposed Pad [Also called QFN]

**Note:** For the most current package drawings, please see the Microchip Packaging Specification located at <http://www.microchip.com/packaging>



Dimension Limits	Units	MILLIMETERS		
		MIN	NOM	MAX
Number of Pins	N	64		
Pitch	e	0.50 BSC		
Overall Height	A	0.80	0.90	1.00
Standoff	A1	0.00	0.02	0.05
Contact Thickness	A3	0.20 REF		
Overall Width	E	9.00 BSC		
Exposed Pad Width	E2	7.05	7.15	7.25
Overall Length	D	9.00 BSC		
Exposed Pad Length	D2	7.05	7.15	7.25
Contact Width	b	0.18	0.25	0.30
Contact Length	L	0.30	0.40	0.50
Contact-to-Exposed Pad	K	0.20	-	-

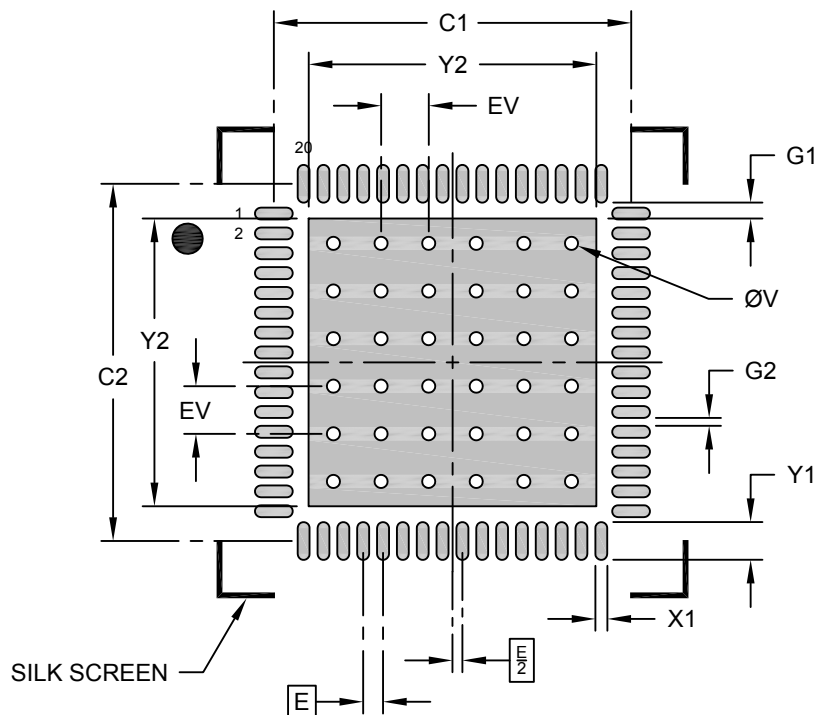
**Notes:**

1. Pin 1 visual index feature may vary, but must be located within the hatched area.
2. Package is saw singulated
3. Dimensioning and tolerancing per ASME Y14.5M
  - BSC: Basic Dimension. Theoretically exact value shown without tolerances.
  - REF: Reference Dimension, usually without tolerance, for information purposes only.

Microchip Technology Drawing C04-149 [MR] Rev E Sheet 2 of 2

### 64-Lead Very Thin Plastic Quad Flat, No Lead Package (MR) – 9x9x0.9 mm Body [VQFN] With 7.15 x 7.15 Exposed Pad [Also called QFN]

**Note:** For the most current package drawings, please see the Microchip Packaging Specification located at <http://www.microchip.com/packaging>



RECOMMENDED LAND PATTERN

Dimension Limits	Units	MILLIMETERS		
		MIN	NOM	MAX
Contact Pitch	E	0.50 BSC		
Optional Center Pad Width	X2			7.25
Optional Center Pad Length	Y2			7.25
Contact Pad Spacing	C1		9.00	
Contact Pad Spacing	C2		9.00	
Contact Pad Width (X64)	X1			0.30
Contact Pad Length (X64)	Y1			0.95
Contact Pad to Center Pad (X64)	G1	0.40		
Spacing Between Contact Pads (X60)	G2	0.20		
Thermal Via Diameter	V		0.33	
Thermal Via Pitch	EV		1.20	

Notes:

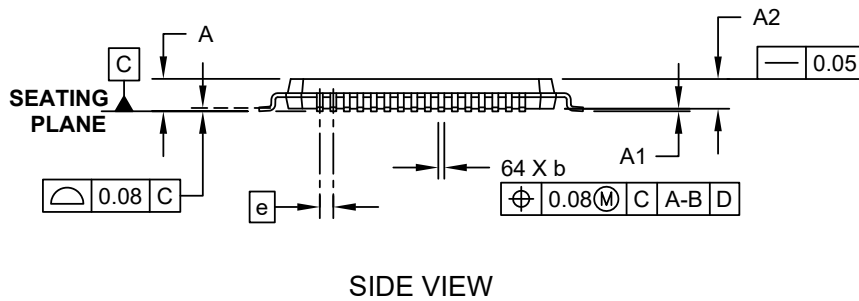
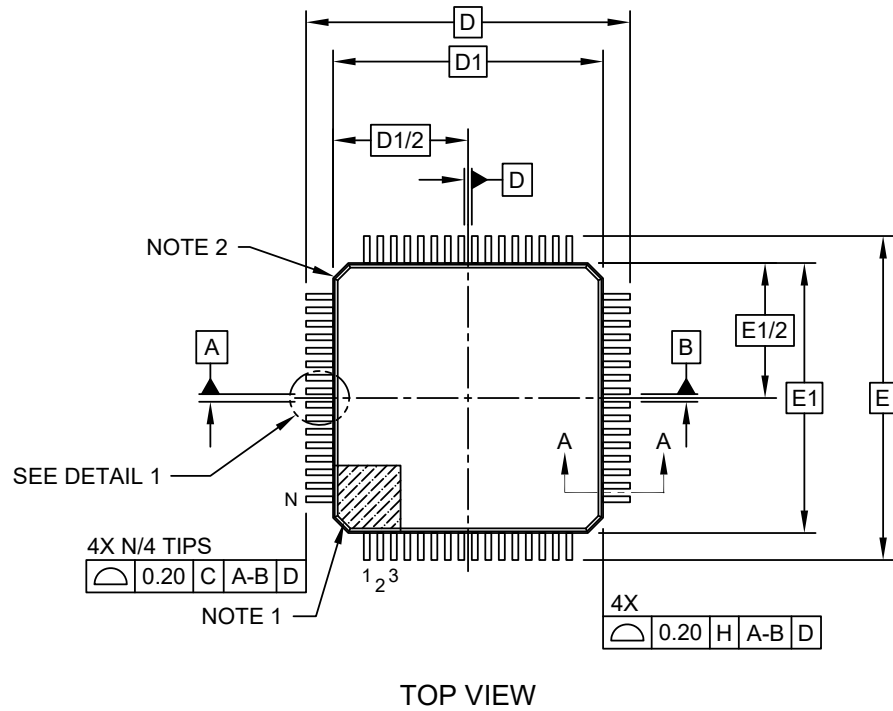
- Dimensioning and tolerancing per ASME Y14.5M  
BSC: Basic Dimension. Theoretically exact value shown without tolerances.
- For best soldering results, thermal vias, if used, should be filled or tented to avoid solder loss during reflow process

Microchip Technology Drawing C04-149 [MR] Rev E

40.10 64-Pin TQFP

64-Lead Plastic Thin Quad Flatpack (PT)-10x10x1 mm Body, 2.00 mm Footprint [TQFP]

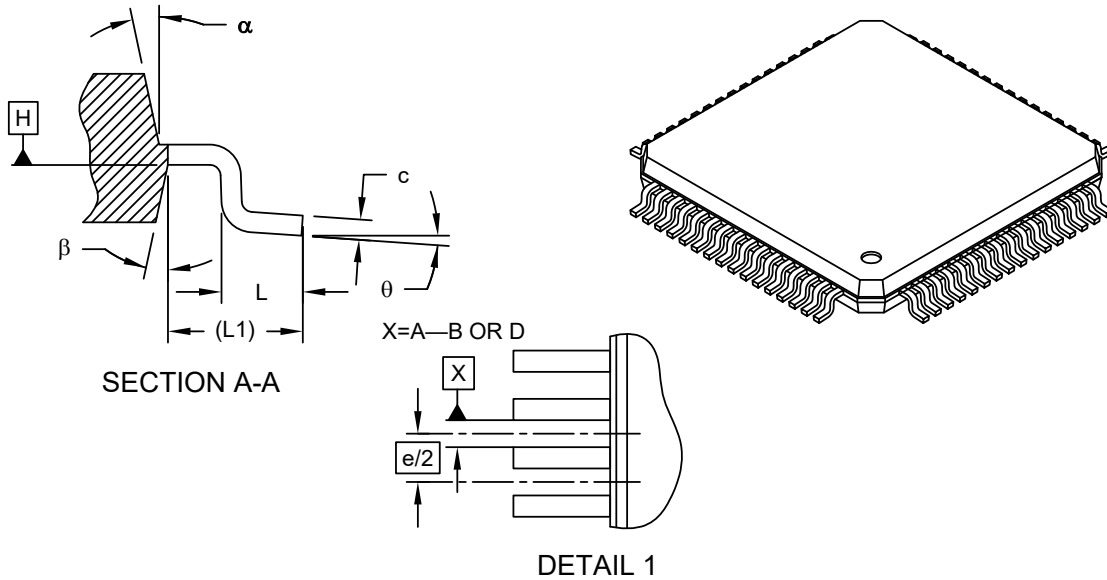
**Note:** For the most current package drawings, please see the Microchip Packaging Specification located at <http://www.microchip.com/packaging>



Microchip Technology Drawing C04-085C Sheet 1 of 2

64-Lead Plastic Thin Quad Flatpack (PT)-10x10x1 mm Body, 2.00 mm Footprint [TQFP]

**Note:** For the most current package drawings, please see the Microchip Packaging Specification located at <http://www.microchip.com/packaging>



Dimension	Units	MILLIMETERS		
		MIN	NOM	MAX
Number of Leads	N	64		
Lead Pitch	e	0.50 BSC		
Overall Height	A	-	-	1.20
Molded Package Thickness	A2	0.95	1.00	1.05
Standoff	A1	0.05	-	0.15
Foot Length	L	0.45	0.60	0.75
Footprint	L1	1.00 REF		
Foot Angle	$\phi$	0°	3.5°	7°
Overall Width	E	12.00 BSC		
Overall Length	D	12.00 BSC		
Molded Package Width	E1	10.00 BSC		
Molded Package Length	D1	10.00 BSC		
Lead Thickness	c	0.09	-	0.20
Lead Width	b	0.17	0.22	0.27
Mold Draft Angle Top	$\alpha$	11°	12°	13°
Mold Draft Angle Bottom	$\beta$	11°	12°	13°

Notes:

1. Pin 1 visual index feature may vary, but must be located within the hatched area.
2. Chamfers at corners are optional; size may vary.
3. Dimensions D1 and E1 do not include mold flash or protrusions. Mold flash or protrusions shall not exceed 0.25mm per side.
4. Dimensioning and tolerancing per ASME Y14.5M

BSC: Basic Dimension. Theoretically exact value shown without tolerances.

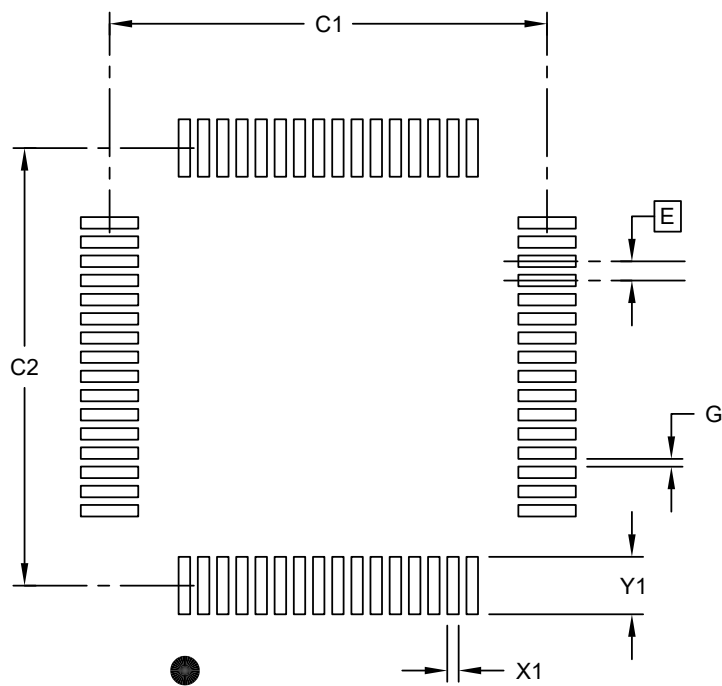
REF: Reference Dimension, usually without tolerance, for information purposes only.

Microchip Technology Drawing C04-085C Sheet 2 of 2



### 64-Lead Plastic Thin Quad Flatpack (PT)-10x10x1 mm Body, 2.00 mm Footprint [TQFP]

**Note:** For the most current package drawings, please see the Microchip Packaging Specification located at <http://www.microchip.com/packaging>



RECOMMENDED LAND PATTERN

Dimension Limits	Units	MILLIMETERS		
		MIN	NOM	MAX
Contact Pitch	E	0.50 BSC		
Contact Pad Spacing	C1		11.40	
Contact Pad Spacing	C2		11.40	
Contact Pad Width (X28)	X1			0.30
Contact Pad Length (X28)	Y1			1.50
Distance Between Pads	G	0.20		

**Notes:**

1. Dimensioning and tolerancing per ASME Y14.5M  
BSC: Basic Dimension. Theoretically exact value shown without tolerances.

Microchip Technology Drawing C04-2085B Sheet 1 of 1

## 41. Data Sheet Revision History

**Note:** The data sheet revision is independent of the die revision and the device variant (last letter of the ordering number).

### 41.1

#### Rev. B - 07/2020

Section	Changes
Entire Document	<ul style="list-style-type: none"> <li>Updated AVR® MCU DA (AVR-DA) to AVR® DA MCU, and AVR-DA to AVR DA, per latest trademarking</li> <li>Editorial updates</li> </ul>
Hardware Guidelines	<ul style="list-style-type: none"> <li>Changed the value of the primary decoupling capacitor from 100 nF to 1 <math>\mu</math>F</li> </ul>
Sleep Controller	<ul style="list-style-type: none"> <li>Added the High-Temperature Low Leakage Enable (HTLLEN) bit in the VREGCTRL register</li> </ul>
Electrical characteristics	<ul style="list-style-type: none"> <li>Added Supply Voltage Slew Rate</li> <li>Updated I/O Pin characteristics (Input Leakage current)</li> </ul>

#### Rev. A - 03/2020

Section	Changes
Document	Initial release

## The Microchip Website

---

Microchip provides online support via our website at [www.microchip.com/](http://www.microchip.com/). This website is used to make files and information easily available to customers. Some of the content available includes:

- **Product Support** – Data sheets and errata, application notes and sample programs, design resources, user's guides and hardware support documents, latest software releases and archived software
- **General Technical Support** – Frequently Asked Questions (FAQs), technical support requests, online discussion groups, Microchip design partner program member listing
- **Business of Microchip** – Product selector and ordering guides, latest Microchip press releases, listing of seminars and events, listings of Microchip sales offices, distributors and factory representatives

## Product Change Notification Service

---

Microchip's product change notification service helps keep customers current on Microchip products. Subscribers will receive email notification whenever there are changes, updates, revisions or errata related to a specified product family or development tool of interest.

To register, go to [www.microchip.com/pcn](http://www.microchip.com/pcn) and follow the registration instructions.

## Customer Support

---

Users of Microchip products can receive assistance through several channels:

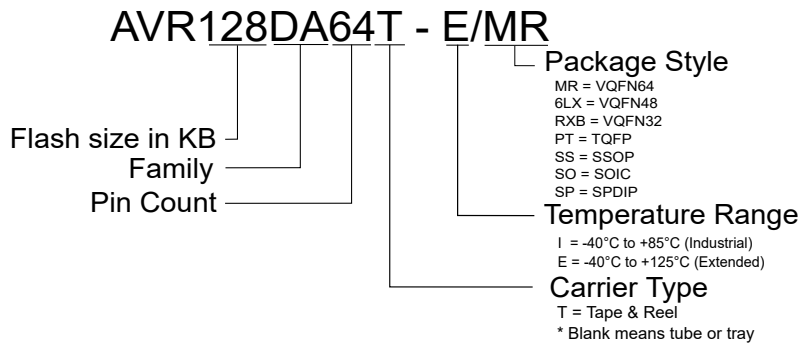
- Distributor or Representative
- Local Sales Office
- Embedded Solutions Engineer (ESE)
- Technical Support

Customers should contact their distributor, representative or ESE for support. Local sales offices are also available to help customers. A listing of sales offices and locations is included in this document.

Technical support is available through the website at: [www.microchip.com/support](http://www.microchip.com/support)

## Product Identification System

To order or obtain information, e.g., on pricing or delivery, refer to the factory or the listed sales office.



**Note:** The Tape and Reel identifier only appears in the catalog part number description. This identifier is used for ordering purposes and is not printed on the device package. Check with your [Microchip Sales Office](#) for package availability with the Tape and Reel option.

## Microchip Devices Code Protection Feature

Note the following details of the code protection feature on Microchip devices:

- Microchip products meet the specifications contained in their particular Microchip Data Sheet.
- Microchip believes that its family of products is secure when used in the intended manner and under normal conditions.
- There are dishonest and possibly illegal methods being used in attempts to breach the code protection features of the Microchip devices. We believe that these methods require using the Microchip products in a manner outside the operating specifications contained in Microchip's Data Sheets. Attempts to breach these code protection features, most likely, cannot be accomplished without violating Microchip's intellectual property rights.
- Microchip is willing to work with any customer who is concerned about the integrity of its code.
- Neither Microchip nor any other semiconductor manufacturer can guarantee the security of its code. Code protection does not mean that we are guaranteeing the product is "unbreakable." Code protection is constantly evolving. We at Microchip are committed to continuously improving the code protection features of our products. Attempts to break Microchip's code protection feature may be a violation of the Digital Millennium Copyright Act. If such acts allow unauthorized access to your software or other copyrighted work, you may have a right to sue for relief under that Act.

## Legal Notice

Information contained in this publication is provided for the sole purpose of designing with and using Microchip products. Information regarding device applications and the like is provided only for your convenience and may be superseded by updates. It is your responsibility to ensure that your application meets with your specifications.

THIS INFORMATION IS PROVIDED BY MICROCHIP "AS IS". MICROCHIP MAKES NO REPRESENTATIONS OR WARRANTIES OF ANY KIND WHETHER EXPRESS OR IMPLIED, WRITTEN OR ORAL, STATUTORY OR OTHERWISE, RELATED TO THE INFORMATION INCLUDING BUT NOT LIMITED TO ANY IMPLIED WARRANTIES OF NON-INFRINGEMENT, MERCHANTABILITY, AND FITNESS FOR A PARTICULAR PURPOSE OR WARRANTIES RELATED TO ITS CONDITION, QUALITY, OR PERFORMANCE.

IN NO EVENT WILL MICROCHIP BE LIABLE FOR ANY INDIRECT, SPECIAL, PUNITIVE, INCIDENTAL OR CONSEQUENTIAL LOSS, DAMAGE, COST OR EXPENSE OF ANY KIND WHATSOEVER RELATED TO THE INFORMATION OR ITS USE, HOWEVER CAUSED, EVEN IF MICROCHIP HAS BEEN ADVISED OF THE POSSIBILITY OR THE DAMAGES ARE FORESEEABLE. TO THE FULLEST EXTENT ALLOWED BY LAW, MICROCHIP'S TOTAL LIABILITY ON ALL CLAIMS IN ANY WAY RELATED TO THE INFORMATION OR ITS USE

WILL NOT EXCEED THE AMOUNT OF FEES, IF ANY, THAT YOU HAVE PAID DIRECTLY TO MICROCHIP FOR THE INFORMATION. Use of Microchip devices in life support and/or safety applications is entirely at the buyer's risk, and the buyer agrees to defend, indemnify and hold harmless Microchip from any and all damages, claims, suits, or expenses resulting from such use. No licenses are conveyed, implicitly or otherwise, under any Microchip intellectual property rights unless otherwise stated.

## **Trademarks**

---

The Microchip name and logo, the Microchip logo, Adaptec, AnyRate, AVR, AVR logo, AVR Freaks, BesTime, BitCloud, chipKIT, chipKIT logo, CryptoMemory, CryptoRF, dsPIC, FlashFlex, flexPWR, HELDO, IGLOO, JukeBlox, KeeLoq, Kleer, LANCheck, LinkMD, maXStylus, maXTouch, MediaLB, megaAVR, Microsemi, Microsemi logo, MOST, MOST logo, MPLAB, OptoLyzer, PackeTime, PIC, picoPower, PICSTART, PIC32 logo, PolarFire, Prochip Designer, QTouch, SAM-BA, SenGenuity, SpyNIC, SST, SST Logo, SuperFlash, Symmetricom, SyncServer, Tachyon, TempTrackr, TimeSource, tinyAVR, UNI/O, Vectron, and XMEGA are registered trademarks of Microchip Technology Incorporated in the U.S.A. and other countries.

APT, ClockWorks, The Embedded Control Solutions Company, EtherSynch, FlashTec, Hyper Speed Control, HyperLight Load, IntelliMOS, Libero, motorBench, mTouch, Powermite 3, Precision Edge, ProASIC, ProASIC Plus, ProASIC Plus logo, Quiet-Wire, SmartFusion, SyncWorld, Temux, TimeCesium, TimeHub, TimePictra, TimeProvider, Vite, WinPath, and ZL are registered trademarks of Microchip Technology Incorporated in the U.S.A.

Adjacent Key Suppression, AKS, Analog-for-the-Digital Age, Any Capacitor, AnyIn, AnyOut, BlueSky, BodyCom, CodeGuard, CryptoAuthentication, CryptoAutomotive, CryptoCompanion, CryptoController, dsPICDEM, dsPICDEM.net, Dynamic Average Matching, DAM, ECAN, EtherGREEN, In-Circuit Serial Programming, ICSP, INICnet, Inter-Chip Connectivity, JitterBlocker, KleerNet, KleerNet logo, memBrain, Mindi, MiWi, MPASM, MPF, MPLAB Certified logo, MPLIB, MPLINK, MultiTRAK, NetDetach, Omniscient Code Generation, PICDEM, PICDEM.net, PICkit, PICtail, PowerSmart, PureSilicon, QMatrix, REAL ICE, Ripple Blocker, SAM-ICE, Serial Quad I/O, SMART-I.S., SQI, SuperSwitcher, SuperSwitcher II, Total Endurance, TSHARC, USBCheck, VariSense, ViewSpan, WiperLock, Wireless DNA, and ZENA are trademarks of Microchip Technology Incorporated in the U.S.A. and other countries.

SQTP is a service mark of Microchip Technology Incorporated in the U.S.A.

The Adaptec logo, Frequency on Demand, Silicon Storage Technology, and Symmcom are registered trademarks of Microchip Technology Inc. in other countries.

GestIC is a registered trademark of Microchip Technology Germany II GmbH & Co. KG, a subsidiary of Microchip Technology Inc., in other countries.

All other trademarks mentioned herein are property of their respective companies.

© 2020, Microchip Technology Incorporated, Printed in the U.S.A., All Rights Reserved.

ISBN: 978-1-5224-6401-3

## **Quality Management System**

---

For information regarding Microchip's Quality Management Systems, please visit [www.microchip.com/quality](http://www.microchip.com/quality).

## Worldwide Sales and Service

AMERICAS	ASIA/PACIFIC	ASIA/PACIFIC	EUROPE
<p><b>Corporate Office</b> 2355 West Chandler Blvd. Chandler, AZ 85224-6199 Tel: 480-792-7200 Tel: 480-792-7277 Technical Support: <a href="http://www.microchip.com/support">www.microchip.com/support</a> Web Address: <a href="http://www.microchip.com">www.microchip.com</a></p> <p><b>Atlanta</b> Duluth, GA Tel: 678-957-9614 Fax: 678-957-1455</p> <p><b>Austin, TX</b> Tel: 512-257-3370</p> <p><b>Boston</b> Westborough, MA Tel: 774-760-0087 Fax: 774-760-0088</p> <p><b>Chicago</b> Itasca, IL Tel: 630-285-0071 Fax: 630-285-0075</p> <p><b>Dallas</b> Addison, TX Tel: 972-818-7423 Fax: 972-818-2924</p> <p><b>Detroit</b> Novi, MI Tel: 248-848-4000</p> <p><b>Houston, TX</b> Tel: 281-894-5983</p> <p><b>Indianapolis</b> Noblesville, IN Tel: 317-773-8323 Fax: 317-773-5453 Tel: 317-536-2380</p> <p><b>Los Angeles</b> Mission Viejo, CA Tel: 949-462-9523 Fax: 949-462-9608 Tel: 951-273-7800</p> <p><b>Raleigh, NC</b> Tel: 919-844-7510</p> <p><b>New York, NY</b> Tel: 631-435-6000</p> <p><b>San Jose, CA</b> Tel: 408-735-9110 Tel: 408-436-4270</p> <p><b>Canada - Toronto</b> Tel: 905-695-1980 Fax: 905-695-2078</p>	<p><b>Australia - Sydney</b> Tel: 61-2-9868-6733</p> <p><b>China - Beijing</b> Tel: 86-10-8569-7000</p> <p><b>China - Chengdu</b> Tel: 86-28-8665-5511</p> <p><b>China - Chongqing</b> Tel: 86-23-8980-9588</p> <p><b>China - Dongguan</b> Tel: 86-769-8702-9880</p> <p><b>China - Guangzhou</b> Tel: 86-20-8755-8029</p> <p><b>China - Hangzhou</b> Tel: 86-571-8792-8115</p> <p><b>China - Hong Kong SAR</b> Tel: 852-2943-5100</p> <p><b>China - Nanjing</b> Tel: 86-25-8473-2460</p> <p><b>China - Qingdao</b> Tel: 86-532-8502-7355</p> <p><b>China - Shanghai</b> Tel: 86-21-3326-8000</p> <p><b>China - Shenyang</b> Tel: 86-24-2334-2829</p> <p><b>China - Shenzhen</b> Tel: 86-755-8864-2200</p> <p><b>China - Suzhou</b> Tel: 86-186-6233-1526</p> <p><b>China - Wuhan</b> Tel: 86-27-5980-5300</p> <p><b>China - Xian</b> Tel: 86-29-8833-7252</p> <p><b>China - Xiamen</b> Tel: 86-592-2388138</p> <p><b>China - Zhuhai</b> Tel: 86-756-3210040</p>	<p><b>India - Bangalore</b> Tel: 91-80-3090-4444</p> <p><b>India - New Delhi</b> Tel: 91-11-4160-8631</p> <p><b>India - Pune</b> Tel: 91-20-4121-0141</p> <p><b>Japan - Osaka</b> Tel: 81-6-6152-7160</p> <p><b>Japan - Tokyo</b> Tel: 81-3-6880-3770</p> <p><b>Korea - Daegu</b> Tel: 82-53-744-4301</p> <p><b>Korea - Seoul</b> Tel: 82-2-554-7200</p> <p><b>Malaysia - Kuala Lumpur</b> Tel: 60-3-7651-7906</p> <p><b>Malaysia - Penang</b> Tel: 60-4-227-8870</p> <p><b>Philippines - Manila</b> Tel: 63-2-634-9065</p> <p><b>Singapore</b> Tel: 65-6334-8870</p> <p><b>Taiwan - Hsin Chu</b> Tel: 886-3-577-8366</p> <p><b>Taiwan - Kaohsiung</b> Tel: 886-7-213-7830</p> <p><b>Taiwan - Taipei</b> Tel: 886-2-2508-8600</p> <p><b>Thailand - Bangkok</b> Tel: 66-2-694-1351</p> <p><b>Vietnam - Ho Chi Minh</b> Tel: 84-28-5448-2100</p>	<p><b>Austria - Wels</b> Tel: 43-7242-2244-39 Fax: 43-7242-2244-393</p> <p><b>Denmark - Copenhagen</b> Tel: 45-4485-5910 Fax: 45-4485-2829</p> <p><b>Finland - Espoo</b> Tel: 358-9-4520-820</p> <p><b>France - Paris</b> Tel: 33-1-69-53-63-20 Fax: 33-1-69-30-90-79</p> <p><b>Germany - Garching</b> Tel: 49-8931-9700</p> <p><b>Germany - Haan</b> Tel: 49-2129-3766400</p> <p><b>Germany - Heilbronn</b> Tel: 49-7131-72400</p> <p><b>Germany - Karlsruhe</b> Tel: 49-721-625370</p> <p><b>Germany - Munich</b> Tel: 49-89-627-144-0 Fax: 49-89-627-144-44</p> <p><b>Germany - Rosenheim</b> Tel: 49-8031-354-560</p> <p><b>Israel - Ra'anana</b> Tel: 972-9-744-7705</p> <p><b>Italy - Milan</b> Tel: 39-0331-742611 Fax: 39-0331-466781</p> <p><b>Italy - Padova</b> Tel: 39-049-7625286</p> <p><b>Netherlands - Drunen</b> Tel: 31-416-690399 Fax: 31-416-690340</p> <p><b>Norway - Trondheim</b> Tel: 47-72884388</p> <p><b>Poland - Warsaw</b> Tel: 48-22-3325737</p> <p><b>Romania - Bucharest</b> Tel: 40-21-407-87-50</p> <p><b>Spain - Madrid</b> Tel: 34-91-708-08-90 Fax: 34-91-708-08-91</p> <p><b>Sweden - Gothenberg</b> Tel: 46-31-704-60-40</p> <p><b>Sweden - Stockholm</b> Tel: 46-8-5090-4654</p> <p><b>UK - Wokingham</b> Tel: 44-118-921-5800 Fax: 44-118-921-5820</p>