

DATA SHEET

SURFACE-MOUNT CERAMIC MULTILAYER CAPACITORS

Low-Inductance

X5R / X7R

6.3 V TO 50 V

10 nF to 1 μ F

RoHS compliant & Halogen Free



SCOPE

This specification describes Mid-voltage X7R series chip capacitors with lead-free terminations

APPLICATIONS

High speed IC packages
 Processor package decoupling
 AC noise reduction in multi-chip modules.

FEATURES

Supplied in tape on reel
 Nickel-barrier end termination
 RoHS compliant
 Halogen Free compliant

ORDERING INFORMATION - GLOBAL PART NUMBER, PHYCOMP

CTC

All part numbers are identified by the series, size, tolerance, TC material, packing style, voltage, process code, termination and capacitance value.

YAGEO BRAND ordering code

GLOBAL PART NUMBER (PREFERRED)

CL XXXX X X XXX X **BB** XXX
 (1) (2) (3) (4) (5) (6)

(1) SIZE – INCH BASED (METRIC)

0204(0510)
 0306(0816)
 0508(1220)
 0612(1632)

(2) TOLERANCE

K = ±10%
 M = ±20%

(3) PACKING STYLE

R = Paper/PE taping reel; Reel 7 inch
 K = Blister taping reel; Reel 7 inch
 P = Paper/PE taping reel; Reel 13 inch
 F = Blister taping reel; Reel 13 inch

(4) TC MATERIAL

X5R / X7R

(5) RATED VOLTAGE

5 = 6.3 V
 6 = 10 V
 7 = 16 V
 8 = 25 V
 9 = 50 V

(6) CAPACITANCE VALUE

2 significant digits+number of zeros
 The 3rd digit signifies the multiplying factor, and letter R is decimal point
 Example: 121 = 12 × 10¹ = 120 pF

CONSTRUCTION

The capacitor consists of a rectangular block of ceramic dielectric in which a number of interleaved metal electrodes are contained. This structure gives rise to a high capacitance per unit volume.

The inner electrodes are connected to the two end terminations and finally covered with a layer of plated tin (NiSn). The terminations are lead-free. A cross section of the structure is shown in Fig.1.

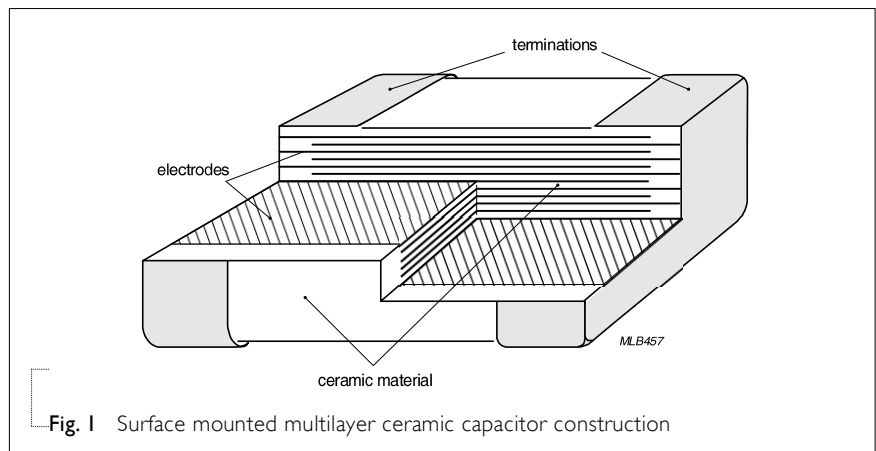

Fig. 1 Surface mounted multilayer ceramic capacitor construction

DIMENSION

Table I For outlines see fig. 2

TYPE	L ₁ (mm)	W (mm)	T (mm)	L ₂ / L ₃ (mm)		L ₄ (mm)
				min.	max.	min.
0204	0.5 ±0.1	1.0 ±0.1	0.3 ±0.1	0.1	0.3	0.1
0306	0.8 ±0.15	1.6 ±0.2	0.5 ±0.1	0.1	0.3	0.2
0508	1.25 ±0.2	2.0 ±0.2	0.85 ±0.1	0.13	0.46	0.38
0612	1.6 ±0.2	3.2 ±0.2	0.85 ±0.1	0.13	0.46	0.50
0612*	1.6 ±0.2	3.2 ±0.2	1.15 ±0.1	0.13	0.46	0.50

0612*: 1uF/16V, 470nF~1uF/25V, 120nF~470nF/50V

OUTLINES

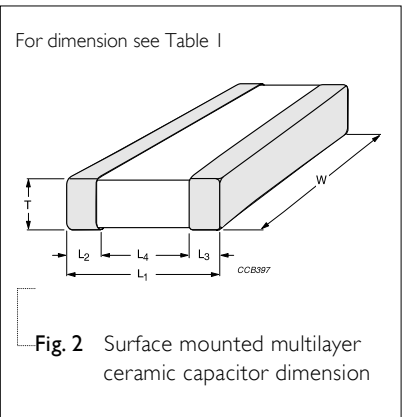

Fig. 2 Surface mounted multilayer ceramic capacitor dimension

CAPACITANCE RANGE & THICKNESS FOR X5R

Table 2 Sizes from 0204

CAP. **0204**
 6.3 V / 10V

10 nF	0.3 ±0.1
15 nF	0.3 ±0.1
22 nF	0.3 ±0.1
33 nF	0.3 ±0.1
47 nF	0.3 ±0.1
68 nF	0.3 ±0.1
100 nF	0.3 ±0.1
150 nF	
220 nF	
330 nF	
470 nF	
680 nF	
1 μF	

NOTE

1. Values in shaded cells indicate thickness class in mm
2. Capacitance value of non E-6 series is on request
3. For special ordering code, please contact local sales force before order.

CAPACITANCE RANGE & THICKNESS FOR X7R

Table 3 Sizes from 0306 to 0508

CAP.	0306		0508		
	6.3 V / 10V		10 V	16 V	25 V
10 nF			0.85 ±0.1	0.85 ±0.1	0.85 ±0.1
15 nF			0.85 ±0.1	0.85 ±0.1	0.85 ±0.1
22 nF			0.85 ±0.1	0.85 ±0.1	0.85 ±0.1
33 nF			0.85 ±0.1	0.85 ±0.1	0.85 ±0.1
47 nF			0.85 ±0.1	0.85 ±0.1	0.85 ±0.1
68 nF			0.85 ±0.1	0.85 ±0.1	0.85 ±0.1
100 nF	0.5 ±0.1		0.85 ±0.1	0.85 ±0.1	0.85 ±0.1
150 nF			0.85 ±0.1	0.85 ±0.1	
220 nF	0.5 ±0.1		0.85 ±0.1	0.85 ±0.1	
330 nF					
470 nF			0.85 ±0.1		
680 nF					
1 uF			0.85 ±0.1		

NOTE

1. Values in shaded cells indicate thickness class in mm
2. Capacitance value of non E-6 series is on request
3. For special ordering code, please contact local sales force before order.

CAPACITANCE RANGE & THICKNESS FOR X7R
Table 4 Sizes from 0612

CAP.	0612				
	6.3 V	10 V	16 V	25 V	50 V
10 nF	0.85 ±0.1	0.85 ±0.1	0.85 ±0.1	0.85 ±0.1	0.85 ±0.1
15 nF	0.85 ±0.1	0.85 ±0.1	0.85 ±0.1	0.85 ±0.1	0.85 ±0.1
22 nF	0.85 ±0.1	0.85 ±0.1	0.85 ±0.1	0.85 ±0.1	0.85 ±0.1
33 nF	0.85 ±0.1	0.85 ±0.1	0.85 ±0.1	0.85 ±0.1	0.85 ±0.1
47 nF	0.85 ±0.1	0.85 ±0.1	0.85 ±0.1	0.85 ±0.1	0.85 ±0.1
68 nF	0.85 ±0.1	0.85 ±0.1	0.85 ±0.1	0.85 ±0.1	0.85 ±0.1
100 nF	0.85 ±0.1	0.85 ±0.1	0.85 ±0.1	0.85 ±0.1	0.85 ±0.1
150 nF	0.85 ±0.1	0.85 ±0.1	0.85 ±0.1	1.15 ±0.1	1.15 ±0.1
220 nF	0.85 ±0.1	0.85 ±0.1	0.85 ±0.1	1.15 ±0.1	1.15 ±0.1
330 nF	0.85 ±0.1	0.85 ±0.1	0.85 ±0.1	1.15 ±0.1	1.15 ±0.1
470 nF	0.85 ±0.1	0.85 ±0.1	0.85 ±0.1	1.15 ±0.1	1.15 ±0.1
680 nF	1.15 ±0.1	1.15 ±0.1	1.15 ±0.1	1.15 ±0.1	1.15 ±0.1
1 µF	1.15 ±0.1	1.15 ±0.1	1.15 ±0.1	1.15 ±0.1	1.15 ±0.1

NOTE

1. Values in shaded cells indicate thickness class in mm
2. Capacitance value of non E-6 series is on request
3. For special ordering code, please contact local sales force before order

THICKNESS CLASSES AND PACKING QUANTITY
Table 5

SIZE CODE	THICKNESS CLASSIFICATION	TAPE WIDTH QUANTITY PER REEL	Ø180 MM / 7 INCH		Ø330 MM / 13 INCH		QUANTITY PER BULK CASE
			Paper	Blister	Paper	Blister	
0204	0.3 ±0.1 mm	8 mm	10,000	---	---	---	---
0306	0.5 ±0.1 mm	8 mm	4,000	---	15,000	---	---
0508	0.85 ±0.1 mm	8 mm	4,000	---	15,000	---	---
0612	0.85 ±0.1 mm	8 mm	4,000	---	15,000	---	---
0612	1.15 ±0.1 mm	8 mm	---	3,000	---	---	---

ELECTRICAL CHARACTERISTICS

X7R DIELECTRIC CAPACITORS;

Unless otherwise specified, all test and measurements shall be made under standard atmospheric conditions for testing as given in 5.3 of IEC 60068-1:

- Temperature: 15 °C to 35 °C
- Relative humidity: 25% to 75%
- Air pressure: 86 kPa to 106 kPa

Before the measurements are made, the capacitor shall be stored at the measuring temperature for a time sufficient to allow the entire capacitor to reach this temperature.

The period as prescribed for recovery at the end of a test is normally sufficient for this purpose.

Table 6

DESCRIPTION	VALUE
Capacitance range	10 nF to 1 uF
Capacitance tolerance	
X5R / X7R	±10%, ±20%
Dissipation factor (D.F.)	
X5R / X7R	≤ 5 %
Insulation resistance after 1 minute at U_r (DC)	$R_{ins} \geq 10 \text{ G}\Omega$ or $R_{ins} \times C \geq 500$ seconds whichever is less
Maximum capacitance change as a function of temperature (temperature characteristic/coefficient):	
X5R / X7R	±15%
Operating temperature range:	
X5R	-55 °C to +85 °C
X7R	-55 °C to +125 °C

SOLDERING RECOMMENDATION

Table 7

SOLDERING METHOD	SIZE			
	0204	0306	0508	0612
Reflow				
Reflow/Wave	○	○	○	○

TESTS AND REQUIREMENTS

Table 8 Test procedures and requirements

TEST	TEST METHOD	PROCEDURE	REQUIREMENTS
Mounting	IEC 4.3 60384-21/22	The capacitors may be mounted on printed-circuit boards or ceramic substrates	No visible damage
Visual Inspection and Dimension Check	4.4	Any applicable method using × 10 magnification	In accordance with specification
Capacitance	4.5.1	Class 2: f = 1 KHz, measuring at voltage 1 Vrms at 20 °C	Within specified tolerance
Dissipation Factor (D.F.)	4.5.2	Class 2: f = 1 KHz, measuring at voltage 1 Vrms at 20 °C	In accordance with specification
Insulation Resistance	4.5.3	At Ur (DC) for 1 minute	In accordance with specification

TEST	TEST METHOD	PROCEDURE	REQUIREMENTS									
Temperature coefficient	4.6	Capacitance shall be measured by the steps shown in the following table. The capacitance change should be measured after 5 min at each specified temperature stage.	Class2: X7R/X5R : $\Delta C/C : \pm 15\%$ In case of applying voltage, the capacitance change should be measured after 1 more min. with applying voltage in equilibration of each temp. stage.									
		<table border="1"> <thead> <tr> <th>Step</th> <th>Temperature(°C)</th> </tr> </thead> <tbody> <tr> <td>a</td> <td>25±2</td> </tr> <tr> <td>b</td> <td>Lower temperature±3°C</td> </tr> <tr> <td>c</td> <td>25±2</td> </tr> <tr> <td>d</td> <td>Upper Temperature±2°C</td> </tr> <tr> <td>e</td> <td>25±2</td> </tr> </tbody> </table> <p>Class II Capacitance Change shall be calculated from the formula as below $\Delta C = \frac{C2 - C1}{C1} \times 100\%$ C1: Capacitance at step c C2: Capacitance at step b or d</p>		Step	Temperature(°C)	a	25±2	b	Lower temperature±3°C	c	25±2	d
Step	Temperature(°C)											
a	25±2											
b	Lower temperature±3°C											
c	25±2											
d	Upper Temperature±2°C											
e	25±2											
Adhesion	IEC 60384-21/22	4.7 A force applied for 10 seconds to the line joining the terminations and in a plane parallel to the substrate	Force size ≥ 0306: 5N size = 0204: 2.5N									
Bending Strength		4.8 Mounting in accordance with IEC 60384-22 paragraph 4.3 Conditions: bending 1 mm at a rate of 1 mm/s, radius jig 5 mm	No visible damage $\Delta C/C$ Class2: X7R/X5R : ±10%									

TEST	TEST METHOD	PROCEDURE	REQUIREMENTS
Resistance to Soldering Heat	4.9	<p>Precondition: 150 +0/-10 °C for 1 hour, then keep for 24 ±1 hours at room temperature</p> <p>Preheating: 120 °C to 150 °C for 1 minute and 170 °C to 200 °C for 1 minute.</p> <p>Solder bath temperature: 260 ±5 °C</p> <p>Dipping time: 10 ±0.5 seconds</p> <p>Recovery time: 24 ±2 hours</p>	<p>Dissolution of the end face plating shall not exceed 25% of the length of the edge concerned</p> <hr/> <p>$\Delta C/C$</p> <p>Class2:</p> <p>X7R/X5R : ±10%</p> <hr/> <p>D.F. within initial specified value</p> <p>R_{ins} within initial specified value</p>
Solderability	4.10	<p>Preheated the temperature of 80 °C to 140 °C and maintained for 30 seconds to 60 seconds.</p> <p>Test conditions for leadfree containing solder alloy</p> <p>Temperature: 245 ±5 °C</p> <p>Dipping time: 3 ±0.3 seconds</p> <p>Depth of immersion: 10 mm</p>	<p>The solder should cover over 95% of the critical area of each termination</p>
Rapid Change of Temperature	IEC 60384-21/22	<p>4.11 Preconditioning; 150 +0/-10 °C for 1 hour, then keep for 24 ±1 hours at room temperature</p> <p>5 cycles with following detail: 30 minutes at lower category temperature 30 minutes at upper category temperature</p> <p>Recovery time 24 ±2 hours</p>	<p>No visual damage</p> <hr/> <p>$\Delta C/C$</p> <p>Class2:</p> <p>X7R/X5R : ±15%</p> <hr/> <p>D.F. meet initial specified value</p> <p>R_{ins} meet initial specified value</p>

TEST	TEST METHOD	PROCEDURE	REQUIREMENTS
Damp Heat with Ur load	4.13	<p>1. Preconditioning, class 2 only: 150 +0/-10 °C /1 hour, then keep for 24 ± 1 hour at room temp</p> <p>2. Initial measure: Spec: refer initial spec C, D, IR</p> <p>3. Damp heat test: 500 ± 12 hours at 40 ± 2 °C; 90 to 95% R.H; 1.0 Ur applied.</p> <p>4. Recovery: Class 1: 6 to 24 hours Class 2: 24 ± 2 hours</p> <p>5. Final measure: C, D, IR</p> <p>P.S. If the capacitance value is less than the minimum value permitted, then after the other measurements have been made the capacitor shall be precondition according to "IEC 60384 4.1" and then the requirement shall be met.</p>	<p>No visual damage after recovery</p> <hr/> <p>$\Delta C/C$ Class2: X7R/X5R : ±20% D.F. Class2: X7R/X5R : ≤ 2 × specified value R_{ins} Class2: X7R/X5R : ≥ 500 MΩ or $R_{ins} \times C_r \geq 25s$ whichever is less</p> <p>$\Delta C/C$ Class2: X7R/X5R : ±25% D.F. Class2: X7R/X5R : ≤ 2 × specified value R_{ins} $R_{ins} \times C_r \geq 25\Omega \cdot F$</p>

TEST	TEST METHOD	PROCEDURE	REQUIREMENTS	
Endurance	IEC 60384-21/22	4.14	<p>1. Preconditioning, class 2 only: 150 +0/-10 °C /1 hour, then keep for 24 ±1 hour at room temp</p> <p>2. Initial measure: Spec: refer initial spec C, D, IR</p> <p>3. Endurance test: Temperature: NP0: 125 °C Specified stress voltage applied for 1,000 hours: Applied 2.0 × U_r for general product Temperature: X7R: 125°C Specified stress voltage applied for 1,000 hours: Recovery time: 24 ±2 hours</p> <p>4. Final measure: C, D, IR</p> <p>P.S. If the capacitance value is less than the minimum value permitted, then after the other measurements have been made the capacitor shall be precondition according to "IEC 60384 4.1" and then the requirement shall be met.</p>	<p>No visual damage</p> <hr/> <p>ΔC/C Class2: X7R/X5R : ±20%</p> <p>D.F. Class2: X7R/X5R : ≤ 2x initial value max</p> <p>R_{ins} Class2: X7R/X5R : ≥ 1,000 MΩ or R_{ins} × Cr ≥ 50s whichever is less</p> <p>Δ C/C Class2: X7R/X5R : ±25%</p> <p>D.F. Class2: X7R/X5R : ≤ 2x initial value max</p> <p>R_{ins} Class2: R_{ins} × Cr ≥ 50 Ω· F</p>
Voltage Proof	IEC 60384-1	4.5.4	<p>Specified stress voltage applied for 1 to 5 seconds U_r ≤ 100 V: series applied 2.5 U_r Charge/Discharge current less than 50mA</p>	No breakdown or flashover

REVISION HISTORY

REVISION	DATE	CHANGE NOTIFICATION	DESCRIPTION
Version 1	Nov. 7, 2016	-	- Add 13" packing
Version 0	Jun. 26, 2015	-	- New