

DATA SHEET

SKY66405-11: 2.4 GHz Front-End Module for Zigbee® / Thread / Bluetooth® Applications

Applications

- In-home appliances
- Smart thermostats
- Internet of Things (IoT) devices
- Smart lighting
- Sensors
- Range extender
- Wireless audio

Features

- Integrated PA with +13 dBm output power
- Integrated LNA (2 dB noise figure typical) and bypass path
- Single-ended transmit/receive interface
- Fast switch on/off time: < 800 ns
- Supply range: 1.7 V to 3.6 V
- Sleep mode current: < 1 μ A typical
- No external bias resistor is required
- Small MCM (1.9 mm x 1.9 mm x 0.56 mm) package, NiPdAu-plated (MSL3, 260 °C per JEDEC-J-STD-020)



Skyworks Green™ products are compliant with all applicable legislation and are halogen-free. For additional information, refer to *Skyworks Definition of Green™*, document number SQ04-0074.

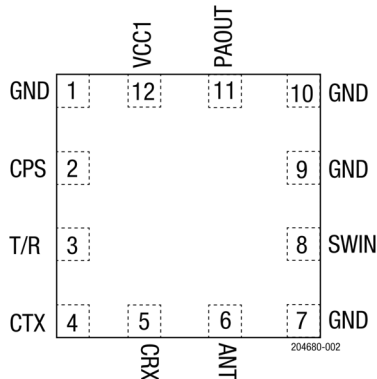

Figure 2. SKY66405-11 Pinout (Top View)

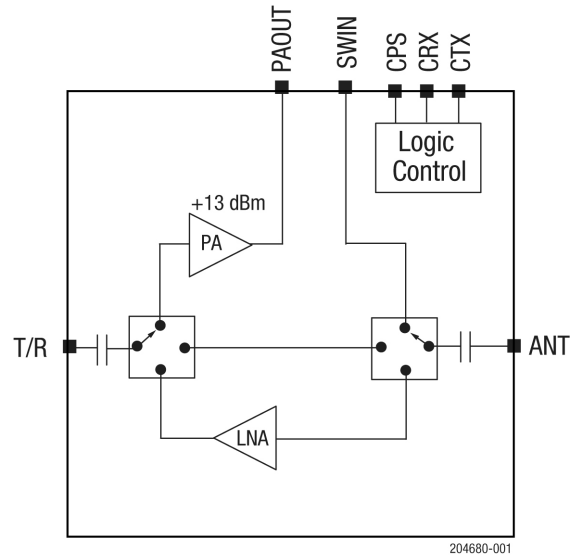

Figure 1. SKY66405-11 Block Diagram

Description

The SKY66405-11 is a high-performance, fully integrated RF front-end module (FEM) designed for Zigbee, Thread, and Bluetooth (including Low Energy) applications.

The SKY66405-11 is designed for ease of use and maximum flexibility. The device provides a power amplifier, low-noise amplifier, low-loss bypass path, transmit/receive switches, and digital controls compatible with 1.6 V to 3.6 V CMOS levels. The RF blocks operate over a wide supply voltage range from 1.7 V to 3.6 V that allows the SKY66405-11 to be used in battery powered applications over a wide spectrum of the battery discharge curve.

A functional block diagram is shown in Figure 1. The SKY66405-11 is provided in a small 1.9 mm x 1.9 mm x 0.56 mm Multi-Chip Module (MCM) package. The pin configuration and package are shown in Figure 2. Signal pin assignments and functional pin descriptions are provided in Table 1.

Table 1. SKY66405-11 Signal Descriptions

Pin	Name	Description	Pin	Name	Description
1	GND	Ground	7	GND	Ground
2	CPS	Bypass mode control input	8	SWIN	Transmit arm to T/R switch; connect to OMN
3	T/R	Connect to 50 Ω transceiver	9	GND	Ground
4	CTX	Transmit mode control input	10	GND	Ground
5	CRX	Receive mode control input	11	PAOUT	PA output; connect to RF choke and OMN
6	ANT	Connect to 50 Ω antenna	12	VCC1	Connect to positive power supply

Electrical and Mechanical Specifications

The absolute maximum ratings of the SKY66405-11 are provided in Table 2. The recommended operating conditions are specified in Table 3.

Electrical specifications are provided in Tables 4 and 5. The state of the SKY66405-11 is determined by the logic provided in Table 6.

Table 2. SKY66405-11 Absolute Maximum Ratings¹

Parameter	Symbol	Minimum	Maximum	Units
Supply voltage	V _{CC1}	-0.3	+3.6	V
	V _{CC2}	-0.3	+3.6	V
Control pin voltages	V _{CTL}	-0.3	+3.6	V
Transmit input power at T/R port	P _{IN_TX}		+8	dBm
Receive input power at ANT ports ²	P _{IN_RX}		+15	dBm
Bypass input power at ANT ports ²	P _{IN_BYP}		+20	dBm
Voltage standing wave ratio	VSWR		10:1	
Operating temperature	T _A	-40	+105	°C
Storage temperature	T _{STG}	-40	+125	°C
Electrostatic discharge:	ESD			
Human Body Model (HBM), Pin 11 (PAOUT)			500	V
Human Body Model (HBM), All other pins			3000	V

¹ Exposure to maximum rating conditions for extended periods may reduce device reliability. There is no damage to device with only one parameter set at the limit and all other parameters set at or below their nominal value. Exceeding any of the limits listed here may result in permanent damage to the device.

² CW test signal.

ESD HANDLING: *Although this device is designed to be as robust as possible, electrostatic discharge (ESD) can damage this device. This device must be protected at all times from ESD when handling or transporting. Static charges may easily produce potentials of several kilovolts on the human body or equipment, which can discharge without detection. Industry-standard ESD handling precautions should be used at all times.*

Table 3. Recommended Operating Conditions

Parameter	Symbol	Min	Typ	Max	Units
Supply voltage on VCC1 pin	Vcc1	1.7	3.3	3.6	V
Supply voltage on PAOUT pin	Vcc2	0.6	3.3	3.6	V
Operating temperature	TA	-40	+25	+105	°C

Table 4. SKY66405-11 DC Electrical Specifications¹
(Vcc1 = Vcc2 = 3.3 V, TA = +25 °C, Unless Otherwise Noted)

Parameter	Symbol	Test Condition	Min	Typ	Max	Units
DC Characteristics						
Transmit operating current	Icc_TX	P _{OUT} = +13 dBm		16		mA
		P _{OUT} = +10 dBm		10		mA
Transmit quiescent current	Iccq_TX			4.0		mA
Receive mode current	Icc_RX			3.5	5.5	mA
Bypass mode current	Icc_BYP			5		μA
Sleep mode current	Icc_OFF	No RF			1	μA
Logic Characteristics						
Control voltage:	V _{IH} V _{IL}		1.6		Vcc1	V
			0		0.3	V
Control current:	I _{IH} I _{IL}				1.0	μA
					1.0	μA

¹ Performance is guaranteed only under the conditions listed in this table.

Table 5. SKY66405-11 AC Electrical Specifications¹
(Vcc1 = Vcc2 = 3.3 V, TA = +25 °C, All Unused Ports Terminated with 50 Ω, Unless Otherwise Noted)

Parameter	Symbol	Test Condition	Min	Typ	Max	Units
Transmit Characteristics						
Frequency range	f		2400		2483.5	MHz
Output power at ANT port	P _{OUT}	P _{IN} = -1 dBm P _{IN} = +3 dBm		+10 +13		dBm dBm
Saturated gain	G _{SAT}	P _{IN} = +3 dBm		10		dB
Small signal gain	S _{21_TX}			11		dB
Saturated output power variation	ΔP _{OUT}				1	dBp-p
Input return loss	S _{11_TX}	T/R port		-10		dB
2 nd to 10 th harmonics ²	2fo to 10fo	P _{OUT} = +13 dBm, BLE source			-30	dBm/MHz
Turn-on time ²	t _{ON_TX}	From 50% of CTX edge to 90% of final RF output power		800		ns
Turn-off time ²	t _{OFF_TX}	From 50% of CTX edge to 10% of initial RF output power		800		ns
Stability ²	STAB	CW, P _{IN} = +3 dBm, 0 GHz to 20 GHz, load VSWR = 6:1	All non-harmonically related outputs < -42 dBm/MHz			
Ruggedness ²	RUG	CW, P _{IN} = +3 dBm, load VSWR = 10:1	No permanent damage			
Receive Characteristics						
Frequency range	f		2400		2483.5	MHz
Receive gain	S _{21_RX}		11.5	13.5	16	dB
Receive noise figure	NF			2		dB
Third order input intercept point	IIP3			2		dBm
1 dB input compression point	IP1dB		-14	-8		dBm
Input return loss	S _{11_RX}	ANT port		-10		dB
Output return loss	S _{22_RX}	T/R port		-10		dB
Turn-on time ²	t _{ON_RX}	From 50% of CRX edge to 90% of final RF output power		800		ns
Turn-off time ²	t _{OFF_RX}	From 50% of CRX edge to 10% of initial RF output power		800		ns
Bypass Characteristics						
Frequency range	f		2400		2483.5	MHz
Bypass gain	S _{21_BYP}			-2		dB
Input return loss	S _{11_BYP}	ANT port		-10		dB
Output return loss	S _{22_BYP}	T/R port		-10		dB

¹ Performance is guaranteed only under the conditions listed in this table.

² Not tested in production. Fully characterized and guaranteed by design.

Table 6. SKY66405-11 Mode Control Logic

State	CTX	CRX	CPS
Sleep	0	0	X
Tx	1	0	0
Rx	0	1	0
BYP	1	1	0
BYP	1	0	1
BYP	0	1	1
BYP	1	1	1

Evaluation Board Description

An Evaluation Board schematic diagram is shown in Figure 3. A reference design schematic is provided in Figure 4.

A photograph of the Evaluation Board is shown in Figure 5. The Evaluation Board Bill of Materials (BOM) is listed in Table 7.

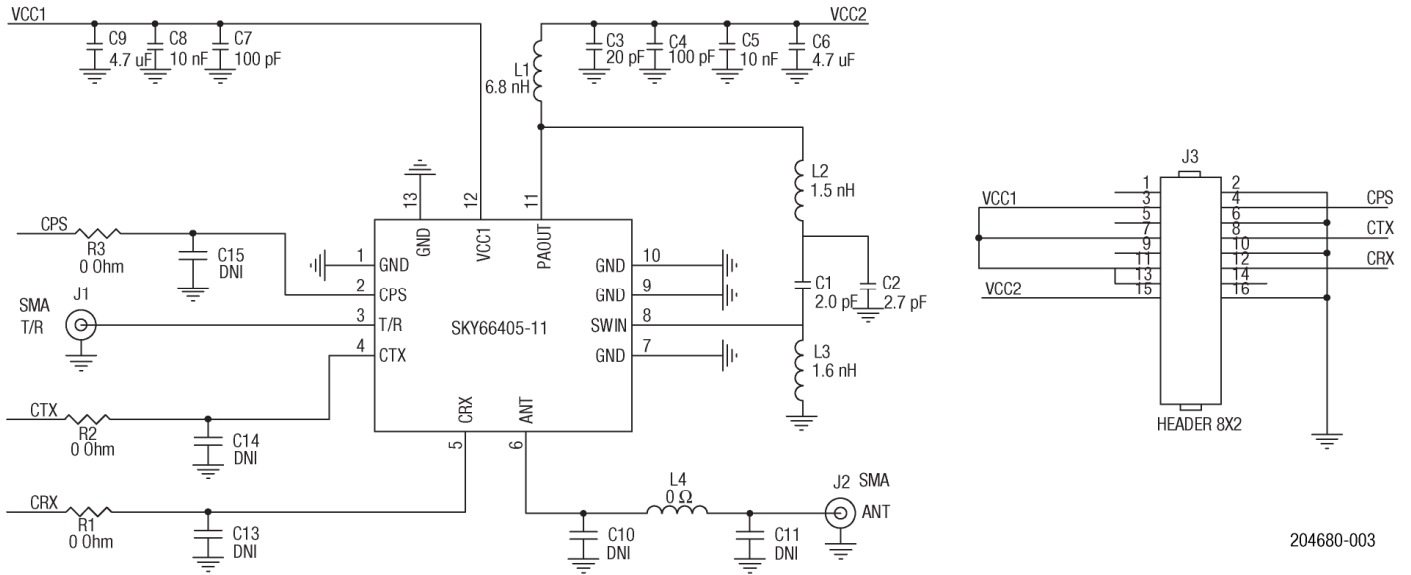

Figure 3. SKY66405-11 Evaluation Board Schematic Diagram

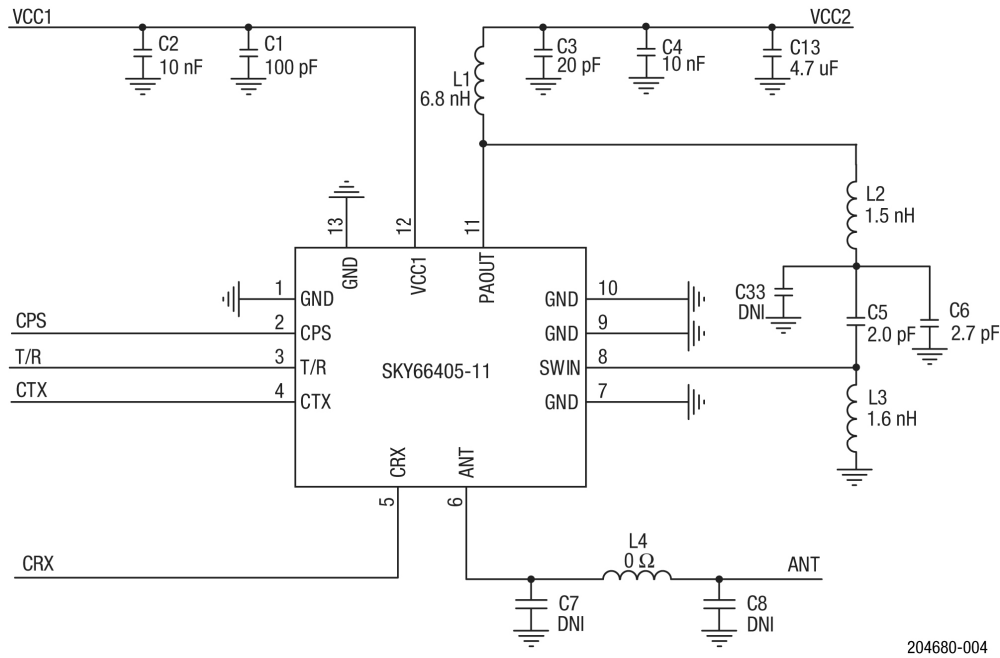

Figure 4. SKY66405-11 Reference Design Schematic

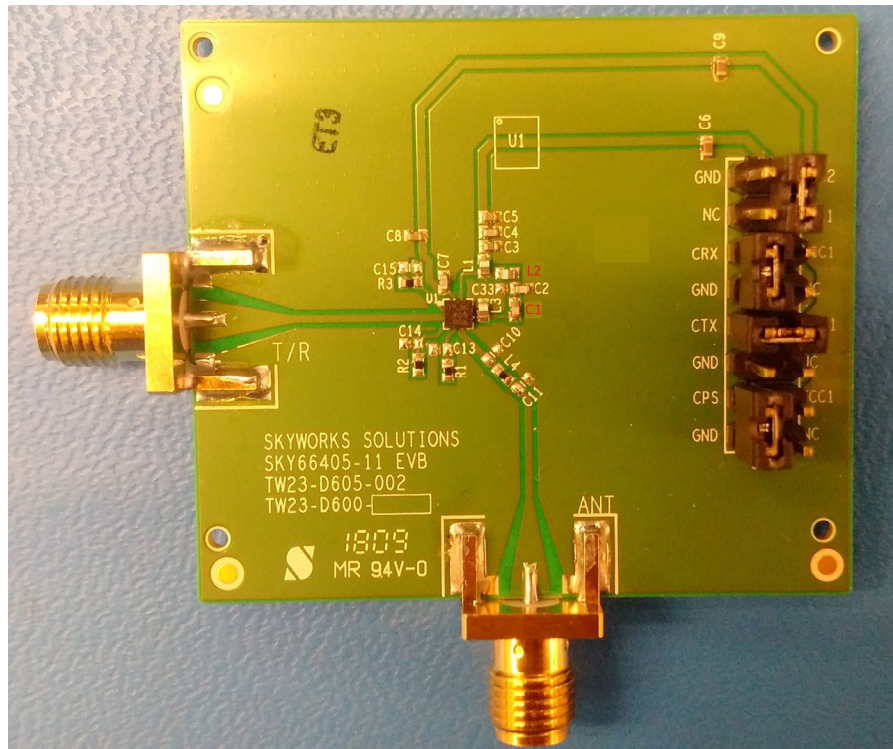

Figure 5. SKY66405-11 Evaluation Board Photograph

Table 7. SKY66405-11 Evaluation Board Bill of Materials

Component	Value	Manufacturer	Mfr Part Number	Size	Description
C1	2 pF		GJM1552C1H2R0WB01	0402	2 pF ±0.05 pF 50 Vdc
C2	2.7 pF		GJM1552C1H2R7BB01	0402	2.7 pF ±0.1 pF 50 Vdc
C3	20 pF	Murata	GRM1555C1H200JZ01	0402	Ceramic capacitor, 20 pF, 5%, COG, 50 V
C4, C7	100 pF	Murata	GRM1555C1H101JZ01	0402	Ceramic capacitor, 100 pF, 5%, COG, 50 V
C5, C8	10 nF		GRM36X7R103J25D500	0402	Ceramic capacitor, 10000 pF, 10%, X7R, 16 V
C6, C9	4.7 uF		C1005X5R1A475KTJ00E	0402	Ceramic capacitor, 4.7 uF, 20%, X5R, 4 V
C10, C11, C13, C14, C15, C33	DNI			0402	
L1	6.8 nH	TDK	MHQ1005P6N8JT000	0402	Inductor, ML-VC, 6.8 nH, 5%, Hi-Q
L2	1.5 nH	TDK	MHQ1005P1N5BT000	0402	Inductor, ML-VC, 1.5 nH, ±0.2 nH, Hi-Q
L3	1.6 nH	TDK	MHQ1005P1N6CT000	0402	Inductor, ML-VC, 1.6 nH, ±0.2 nH, Hi-Q
L4	0 Ω	Panasonic	ERJ2GE0R00	0402	
R1 R2 R3	0 Ω	Panasonic	ERJ2GE0R00	0402	
PCB1	TW23-D605-001-V1	Skyworks	TW23-D605-001-V1		EVB
J3	Header 8×2	Molex		8×2	Header 8×2
U1	SKY66405				

Package Dimensions

The typical part marking is shown in Figure 6. The PCB layout footprint for the SKY66405-11 is provided in Figure 7. Package dimensions are shown in Figure 8, and tape and reel dimensions are provided in Figure 9.

Package and Handling Information

Since the device package is sensitive to moisture absorption, it is baked and vacuum packed before shipping. Instructions on the shipping container label regarding exposure to moisture after the container seal is broken must be followed. Otherwise, problems related to moisture absorption may occur when the part is subjected to high temperature during solder assembly.

The SKY66405-11 is rated to Moisture Sensitivity Level 3 (MSL3) at 260 °C. It can be used for lead or lead-free soldering. For additional information, refer to the Skyworks Application Note, *PCB Design and SMT Assembly/Rework Guidelines for MCM-L Packages*, document number 101752.

Care must be taken when attaching this product, whether it is done manually or in a production solder reflow environment. Production quantities of this product are shipped in a standard tape and reel format.

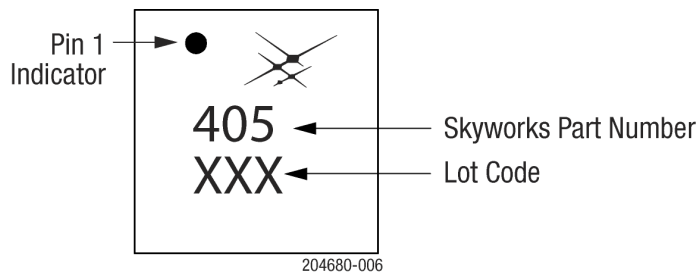
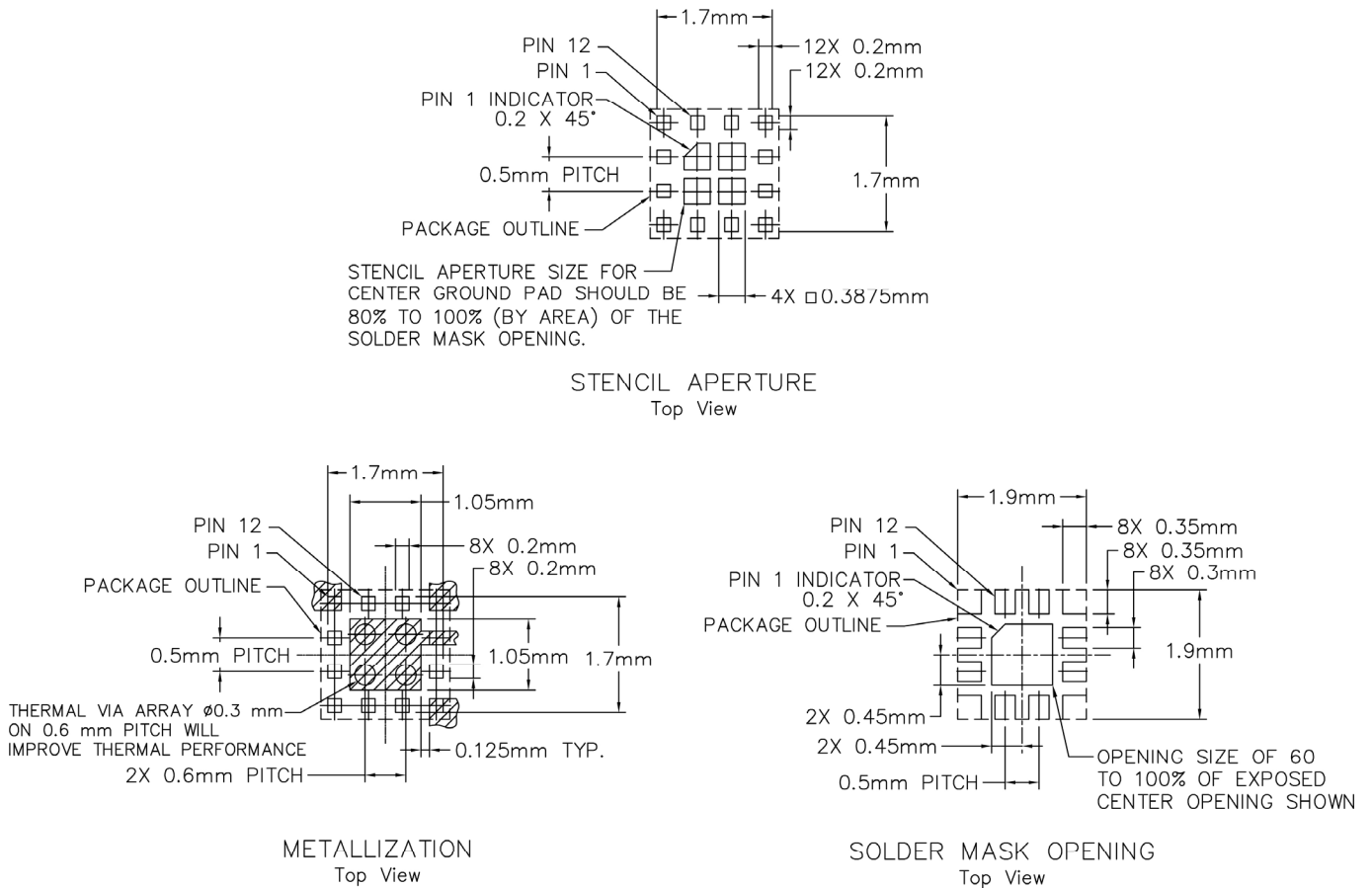

Figure 6. SKY66405-11 Typical Part Marking (Top View)



NOTES:

1. DIMENSIONS ARE IN MILLIMETERS, UNLESS OTHERWISE SPECIFIED.
2. THERMAL VIAS SHOULD BE RESIN FILLED AND CAPPED IN ACCORDANCE WITH IPC-4761 TYPE VII VIAS. 30-35UM Cu THICKNESS IS RECOMMENDED.

204680-007

Figure 7. SKY66405-11 PCB Layout Footprint

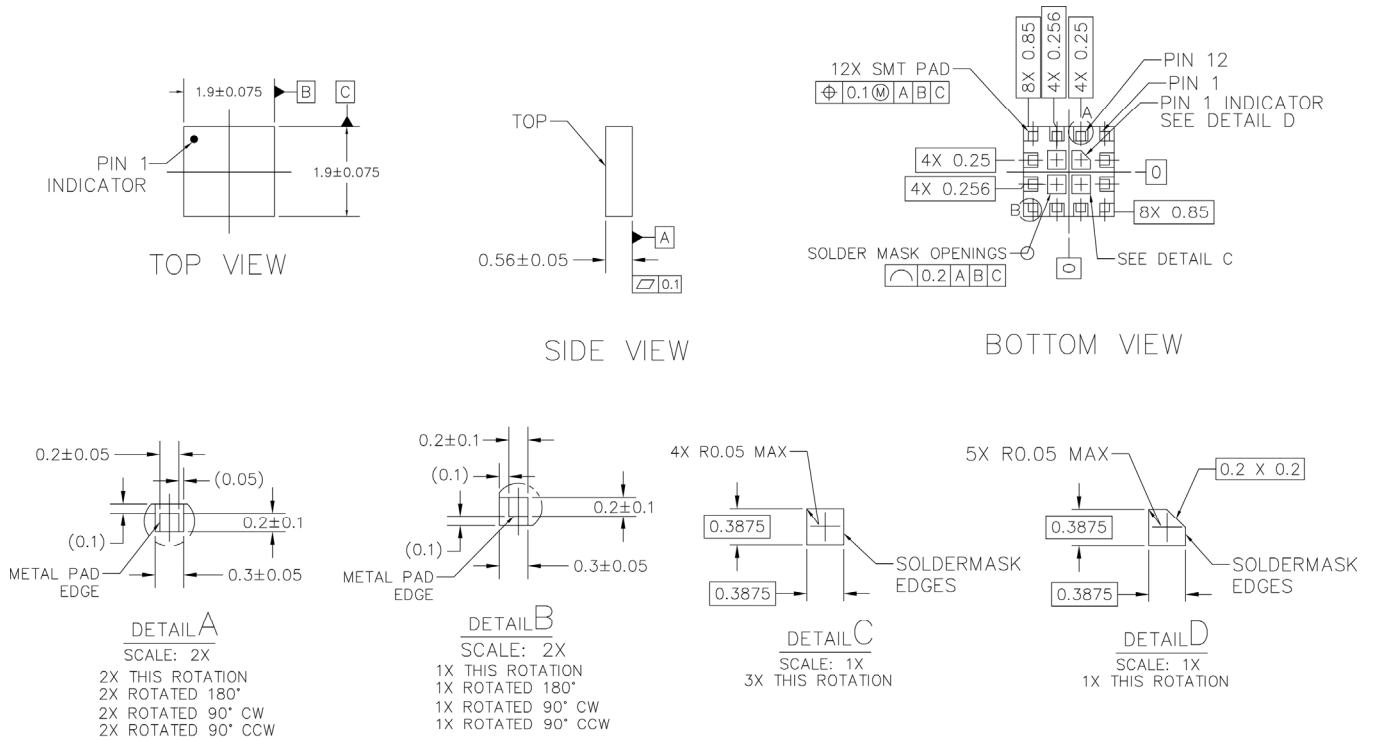

NOTES: UNLESS OTHERWISE SPECIFIED.
1. DIMENSIONING AND TOLERANCING IN ACCORDANCE WITH ASME Y14.5M-1994.
2. DIMENSIONS ARE IN MILLIMETERS

204680-008

Figure 8. SKY66405-11 Package Dimensions

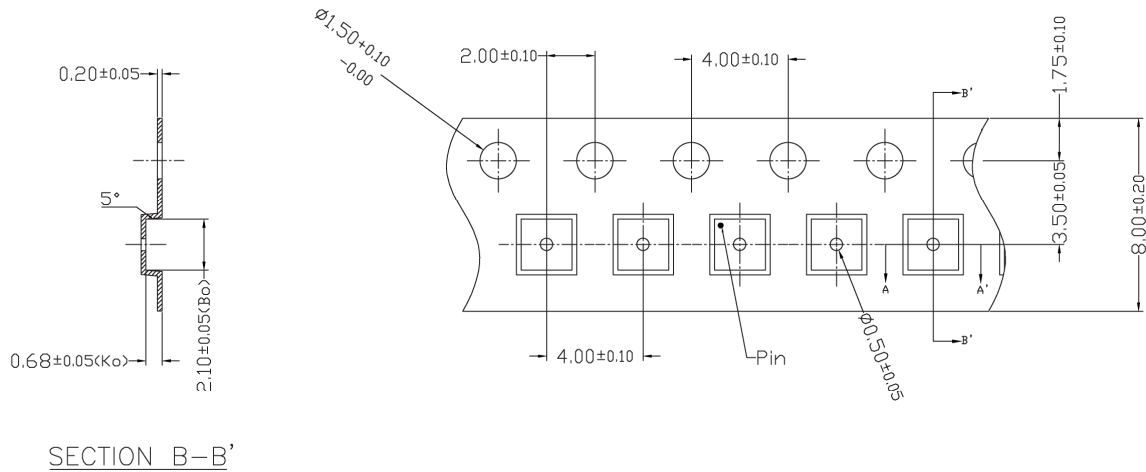

1. CARRIER TAPE MUST MEET ALL SKYWORKS REQUIREMENTS OF GP01-D233 PROCUREMENT SPEC FOR TAPE AND REEL
2. CARRIER TAPE SHALL BE BLACK CONDUCTIVE POLYCARBONATE NON BAKEABLE.
3. COVER TAPE SHALL BE TRANSPARENT CONDUCTIVE MATERIAL
4. ESD-SURFACE RESISTIVITY SHALL MEET GP01-D233
5. 10 SPROCKET HOLE PITCH CUMULATIVE TOLERANCE : ±0.20mm
6. Ao & Bo MEASURED ON PLANE 0.30mm ABOVE THE BOTTOM OF THE POCKET.
7. ALL DIMENSIONS ARE IN MILLIMETERS.

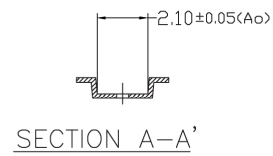

Figure 9. SKY66405-11 Tape and Reel Dimensions

204680-009

Ordering Information

Part Number	Product Description	Evaluation Board Part Number
SKY66405-11	2.4 GHz Zigbee / Thread / Bluetooth FEM	SKY66405-11EK1

Copyright © 2017-2019 Skyworks Solutions, Inc. All Rights Reserved.

Information in this document is provided in connection with Skyworks Solutions, Inc. ("Skyworks") products or services. These materials, including the information contained herein, are provided by Skyworks as a service to its customers and may be used for informational purposes only by the customer. Skyworks assumes no responsibility for errors or omissions in these materials or the information contained herein. Skyworks may change its documentation, products, services, specifications or product descriptions at any time, without notice. Skyworks makes no commitment to update the materials or information and shall have no responsibility whatsoever for conflicts, incompatibilities, or other difficulties arising from any future changes.

No license, whether express, implied, by estoppel or otherwise, is granted to any intellectual property rights by this document. Skyworks assumes no liability for any materials, products or information provided hereunder, including the sale, distribution, reproduction or use of Skyworks products, information or materials, except as may be provided in Skyworks Terms and Conditions of Sale.

THE MATERIALS, PRODUCTS AND INFORMATION ARE PROVIDED "AS IS" WITHOUT WARRANTY OF ANY KIND, WHETHER EXPRESS, IMPLIED, STATUTORY, OR OTHERWISE, INCLUDING FITNESS FOR A PARTICULAR PURPOSE OR USE, MERCHANTABILITY, PERFORMANCE, QUALITY OR NON-INFRINGEMENT OF ANY INTELLECTUAL PROPERTY RIGHT; ALL SUCH WARRANTIES ARE HEREBY EXPRESSLY DISCLAIMED. SKYWORKS DOES NOT WARRANT THE ACCURACY OR COMPLETENESS OF THE INFORMATION, TEXT, GRAPHICS OR OTHER ITEMS CONTAINED WITHIN THESE MATERIALS. SKYWORKS SHALL NOT BE LIABLE FOR ANY DAMAGES, INCLUDING BUT NOT LIMITED TO ANY SPECIAL, INDIRECT, INCIDENTAL, STATUTORY, OR CONSEQUENTIAL DAMAGES, INCLUDING WITHOUT LIMITATION, LOST REVENUES OR LOST PROFITS THAT MAY RESULT FROM THE USE OF THE MATERIALS OR INFORMATION, WHETHER OR NOT THE RECIPIENT OF MATERIALS HAS BEEN ADVISED OF THE POSSIBILITY OF SUCH DAMAGE.

Skyworks products are not intended for use in medical, lifesaving or life-sustaining applications, or other equipment in which the failure of the Skyworks products could lead to personal injury, death, physical or environmental damage. Skyworks customers using or selling Skyworks products for use in such applications do so at their own risk and agree to fully indemnify Skyworks for any damages resulting from such improper use or sale.

Customers are responsible for their products and applications using Skyworks products, which may deviate from published specifications as a result of design defects, errors, or operation of products outside of published parameters or design specifications. Customers should include design and operating safeguards to minimize these and other risks. Skyworks assumes no liability for applications assistance, customer product design, or damage to any equipment resulting from the use of Skyworks products outside of stated published specifications or parameters.

Skyworks and the Skyworks symbol are trademarks or registered trademarks of Skyworks Solutions, Inc. or its subsidiaries in the United States and other countries. Third-party brands and names are for identification purposes only, and are the property of their respective owners. Additional information, including relevant terms and conditions, posted at www.skyworksinc.com, are incorporated by reference.