

Description

RSFP2403D is a high-performance, miniature filter designed for mobile equipment with Wi-Fi band. It is designed with Film Bulk Acoustic Resonator (FBAR) technology, which can provide low insertion loss and steep skirt. So that this product enables coexistence of Wi-Fi and LTE signals within the same device or in close proximity to one another.

For general performance, the RSFP2403D typical insertion loss in the pass band is less than 1.8dB. Typical rejection at the LTE Band 38 and LTE Band 7 and 41 is more than 45dB, at the LTE Band 40 is more than 52dB.

For the chip package, the RSFP2403D uses advanced module packing techniques to achieve the industry standard 1.4x1.1x0.61mm footprint, include bumping and flip chip.



Functional Block Diagram

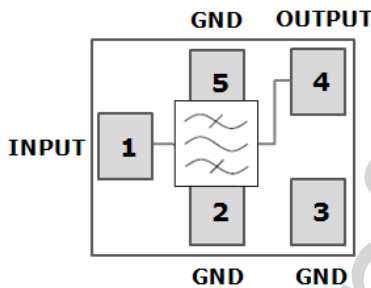

Pin Connection

No.	Function
1	Input
4	Output
2,3,5	Ground

Features

- For Wi-Fi - LTE coexistence application
- Plastic Chip Scale Package(CSP)
- Miniature Size: 1.4mm x 1.1 mm x 0.61 mm
- Fast Roll-off from Wi-Fi to near LTE Bands
- High Rejection at LTE bands.
- Low Temperature Coefficient of Frequency
- ESD protection ability: HBM Class1C
- Moisture Sensitivity : MSL3
- Max Input Power Rating +28dBm

Applications

- Wi-Fi bandpass filter enables the coexistence of (LTE/TD-LTE) & Wi-Fi
- ISM band applications such as Smart Meters
- Portable Hotspots and Mobile Routers

Environmental

- Full implement with RoHS compliant
- Lead Free (Pb free)



Electrical Specifications

Parameter(Operable Temperature:-20 to +90°C)	Min	Typ ⁽¹⁾	Max	Unit
Insertion Loss (2402.5 ~ 2421.5 MHz)	\	1.7	3.1	dB
Insertion Loss (2407.5 ~ 2476.5 MHz)	\	1.4	2.8	dB
Insertion Loss (2462.5 ~ 2481.5 MHz)	\	1.8	3.3	dB
Ripple (2402.5 ~ 2421.5 MHz)	\	0.9	1.3	dB
Ripple (2407.5 ~ 2476.5 MHz)	\	1.2	1.6	dB
Ripple (2462.5 ~ 2481.5 MHz)	\	1.4	1.8	dB
Return Loss (2402.5 ~ 2481.5 MHz)	11	20	\	dB
Absolute Attenuation				
800 ~ 2000 MHz	32	40	\	dB
2000 ~ 2170 MHz	32	38	\	dB
2300 ~ 2370 MHz	42	52	\	dB
2370 ~ 2375 MHz	45	53	\	dB
2375 ~ 2380 MHz	40	56	\	dB
2500 ~ 2505 MHz	30	52	\	dB
2505 ~ 2570 MHz	44	55	\	dB
2570 ~ 2620 MHz	40	48	\	dB
2620 ~ 2690 MHz	38	45	\	dB
4800 ~ 5805 MHz	32	40	\	dB
Max RF Input Power ⁽²⁾ (2402.5 ~ 2481.5 MHz)			28	dBm

(1) **Typ Data** is the integrated value of the linear S-parameter over indicated band.

(2) Input power applied for a minimum of 5,000 hrs at 55°C in the specified frequency band.

Typical Performance at Tc=25 °C

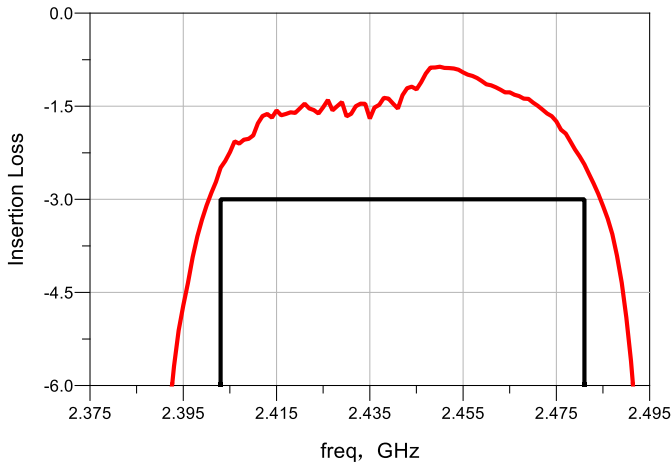

Figure.1 Passband Insertion Loss

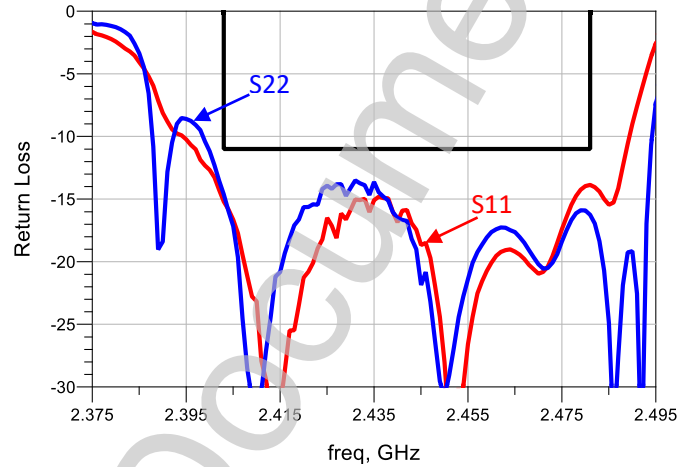

Figure.2 Passband Return Loss

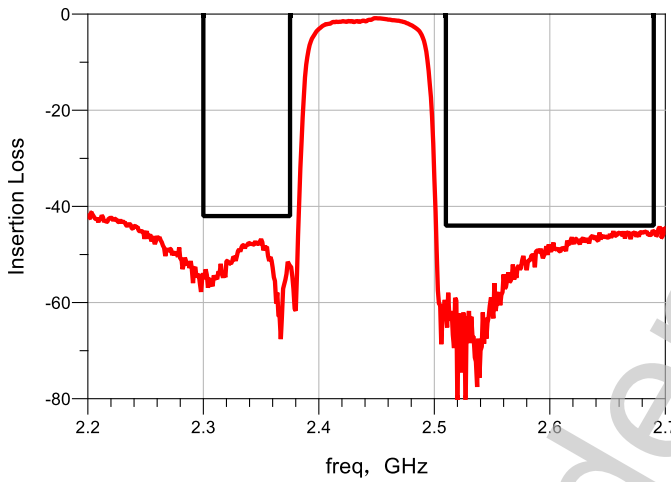

Figure.3 Narrowband Insertion Loss

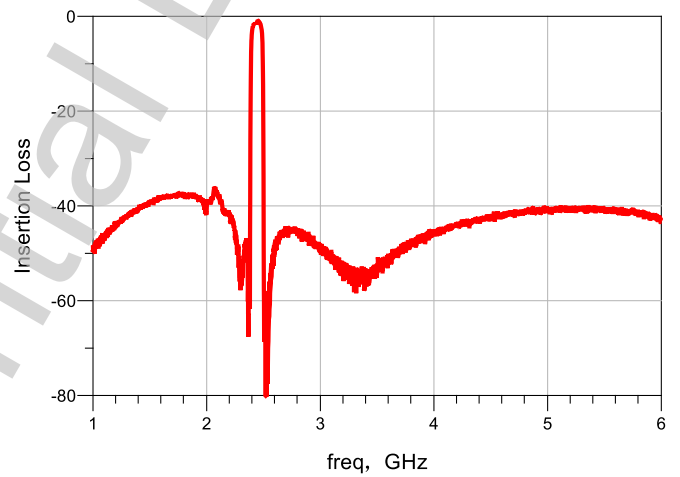

Figure.4 Wideband Insertion Loss

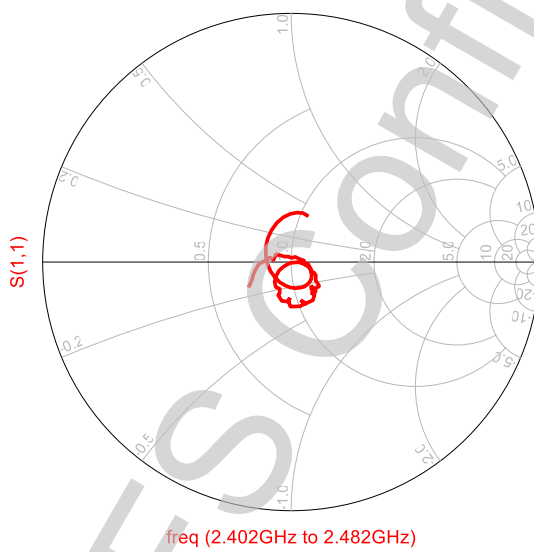

Figure.5 Input Smith Chart S11

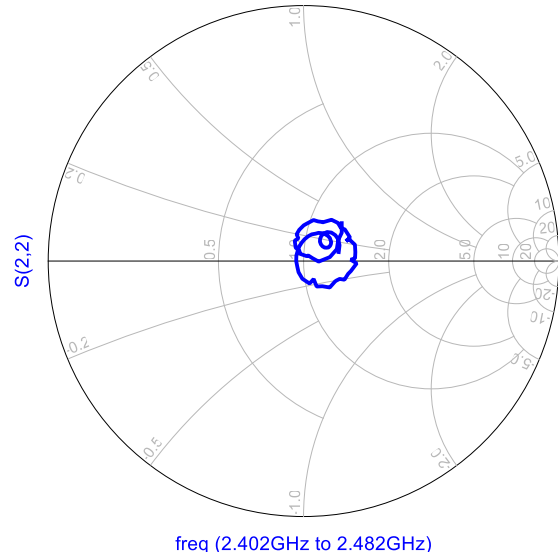
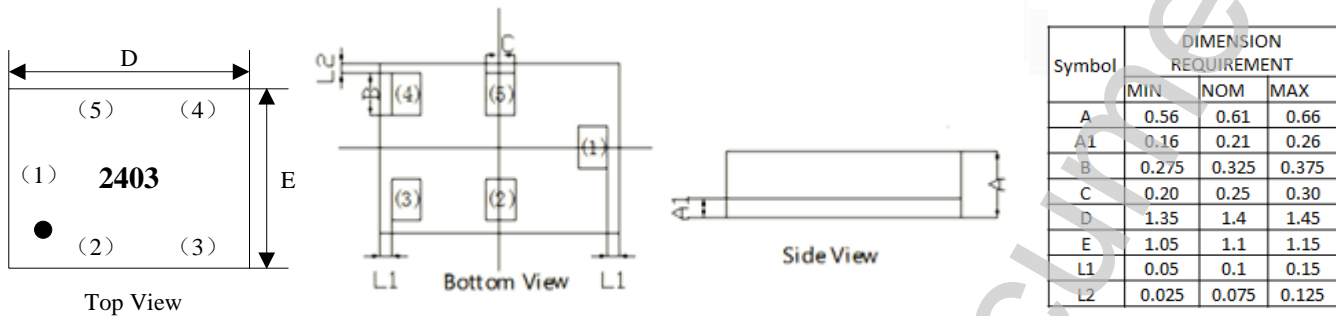

Figure.6 Output Smith Chart S22

Package Outline Drawing



Notes:

1. Dimension: mm
2. Dimensions nominal unless otherwise noted
3. Contact area are gold plated
4. Pad(1) to (5) are same size
5. XX is ROFS inside code

Pin Connection:

- 1 Input
- 4 Output
- 2,3,5 Ground

Test Circuit

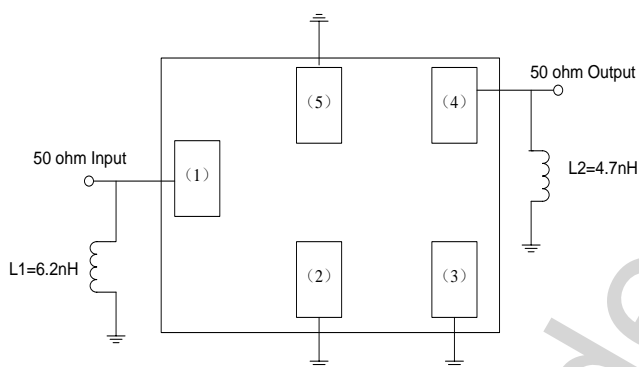

Notes:

1. Matching component values shown are ROFS evaluation board results, please adjust component values by the actual use environment.

PCB Footprint

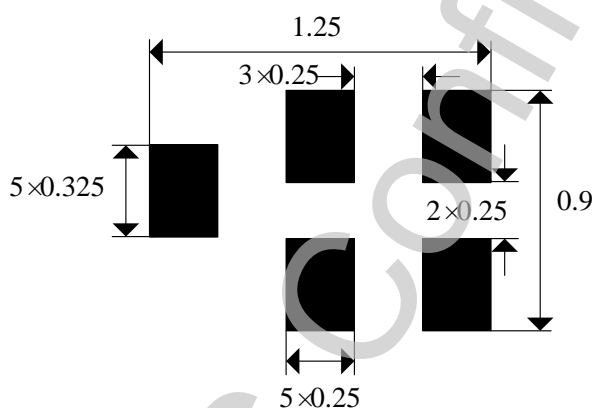

Notes:

1. Black indicates metalized area.
2. This footprint represents a recommendation only, some modification may be necessary to suit end user assembly materials and processes.
3. For solder pad recommendation see mechanical information.
4. Dimensions shown are nominal in millimeters.

Packing

1. Tape Dimension

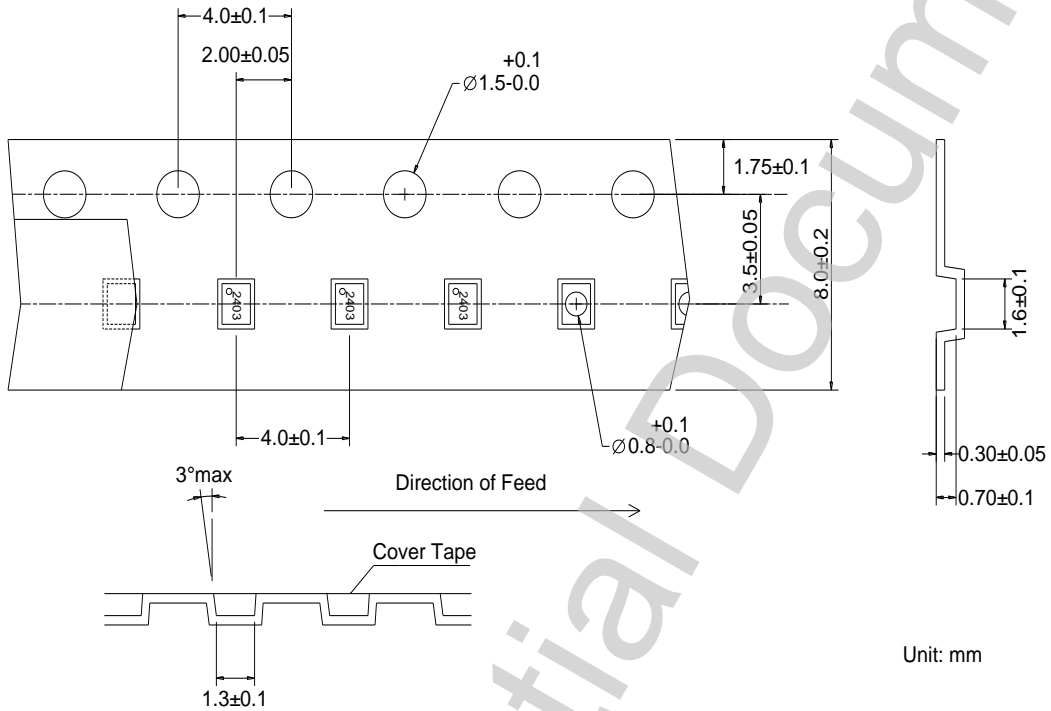

2. Reel Dimension

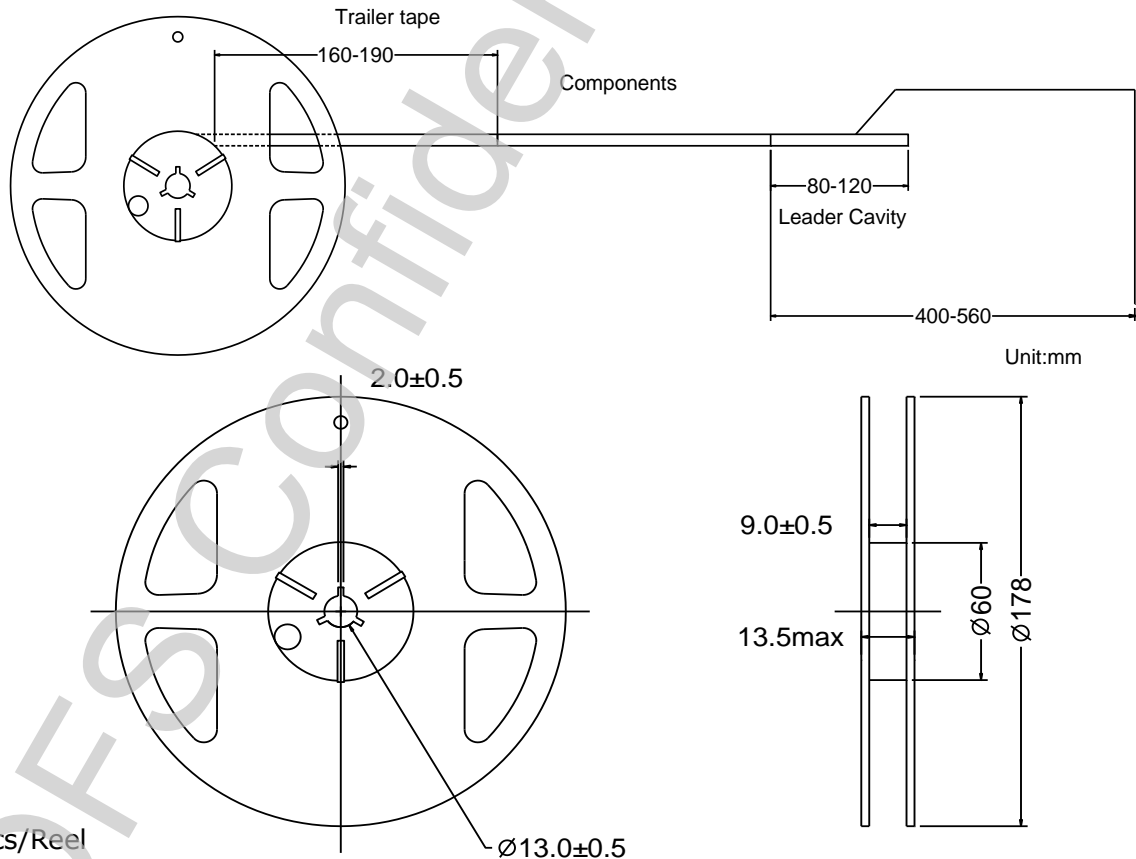

Recommended IR Reflow Profile

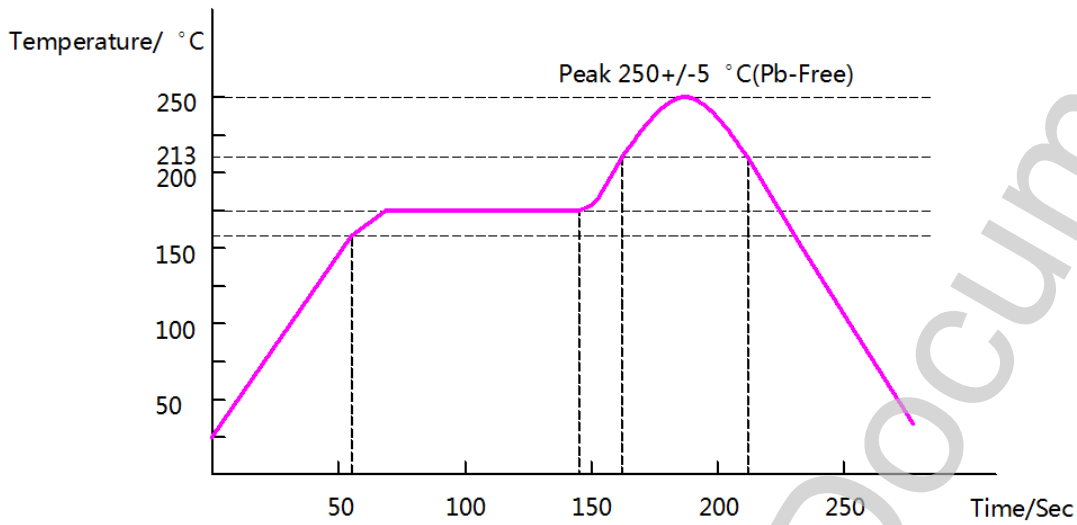

Order Information

Part Number	Qty Per Reel	Container
RSFP2403D	4000	7 inch Reel

For more information, please contact: sales@rofsmicro.com

Notes:

The specification may be changed or the product had been discontinued, please check with our sales or product engineer before order.