

ABIDE BY ROHS

SURFACE WORKING: MT11010
 SW CAP MATERIAL: MITSUBISHI#PC/S-2000

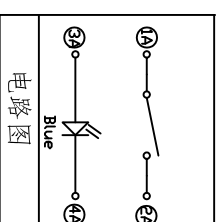
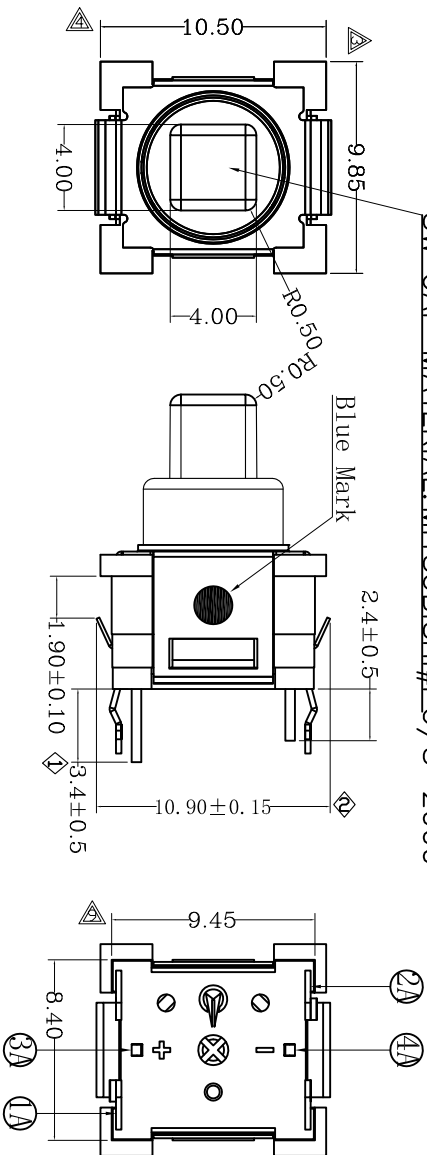

Specification :

1. Rating : DC12V 50mA
2. Contact Resistance : 100mΩ Max@0M Ω Min
3. Insulation Resistance :
4. Withstand Voltage : AC250V (50-60Hz) For 1 minute
5. Operation Force : 450±100gf
6. Life Test : 25,000 Cycles
7. Total Travel : 1.20±0.25mm
8. Operation Type: Touch Restore

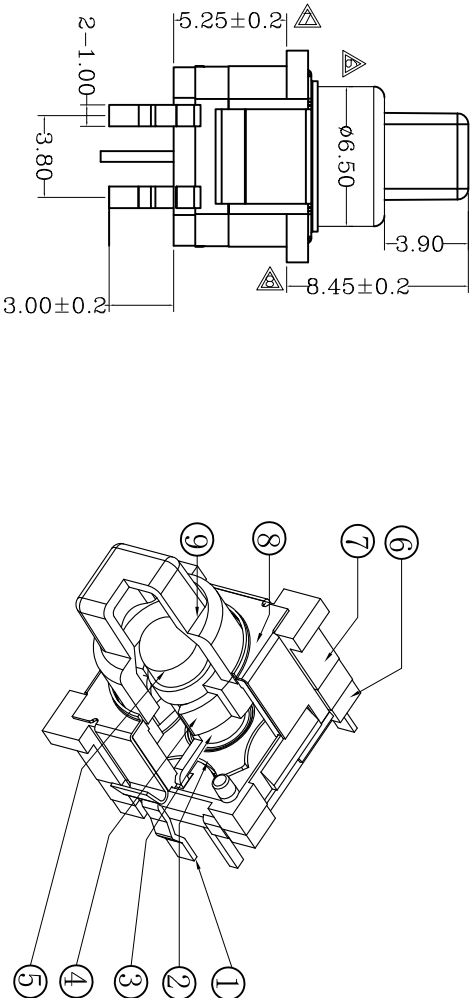

9	Keystroke	1pcs	PC	Transparent
8	Shell	1pcs	SUS301HV	
7	Cover	1pcs	PA10T	Black
6	Base	1pcs	PA10T	Black
5	LED	1pcs	φ2.8mm Super Bright Blue LED	
4	Pad	1pcs	LCP	Black
3	Rubber pod	1pcs	Rubber	Grey
2	Contact	1pcs	SUS301HV	Plating Au(4μm)
1	Terminal	2pcs	Brass	Plating Au(3μm)
ITEM	PART NAME	TER'NO.	MATERIAL	FINISHING
APPROVALS	DATE			
DRAWN	Zhonghuijun	2014.10.10		
CHECKED				
APPROVALS	TITLE:	LA9313 LAMP SWITCH		
	PART NO.	CLA931301D24		
TOLERANCES ARE	30<L	±0.30	ANGLE	
	10<L	±0.20	UNIT: mm	SCALE:
	5<L	±0.15	±2'	DRAWING NO.
	≤5	±0.10		SHEET 1 OF 1



东莞市凯华电子有限公司
 KAIHUA ELECTRONICS CO.,LTD

A

B

C

D

A

B

C

D

ECN NO. A
 REV. 2014.10.10

DESCRIPTION: NEW

CHANGE: CHECK: APPRO.

DATE: 2014.10.10

DATE: 2014.10.10

SCALE:

SHEET 1 OF 1