

Features

- 4.75~36Vin(3.3Vout).6.5-36Vin(5.0Vout).15-36Vin(12.0Vout)
- Fixed Output: 3.3 or 5 or 12V@ 2A
- Vertical SIP, small footprint package
- “No heat sink” direct replacement for 3-terminal78xx-series linear regulators
- High efficiency with no external components
- Short circuit protection
- Outstanding thermal derating performance
- UL/EN/IEC 60950-1, 2nd Edition safety meets

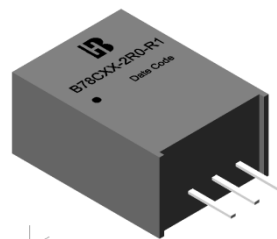

Description

The B78CXX-2R0 Series are non-isolated DC/DC converters suited to replace 2Amp LM78xx linear regulators. Designed with highly efficiency, allow the operating temperature range of these units to be -40°C to +85°C in a 11.6*8.5*17.5mm. Further features include wide 4.75~36VDC input voltage range, short-circuits protection and over temperature protection.

Technical Specification All specifications are typical at nominal input, full load and 25°C unless otherwise stated.

Model Number	Input Voltage Range	Output Voltage (V)	Output Current (mA)		Eff. ⁽²⁾ (%)		Capacitive Load, max. ⁽³⁾ (uF)
			Min. Load ⁽¹⁾	Full. Load	Vin_min	Vin_max.	
B78C03-2R0-R1	4.75-36V Nominal:12V	3.3	0	2000	90	86	1200
B78C05-2R0-R1	6.5-36V Nominal:12V	5	0	2000	93	90	660
B78C12-2R0-R1	15-36V Nominal:24V	12	0	2000	97	93	470
B78C03-2R0	4.75-36V Nominal:12V	3.3	0	2000	90	86	1200
B78C05-2R0	6.5-36V Nominal:12V	5	0	2000	93	90	660
B78C12-2R0	15-36V Nominal:24V	12	0	2000	97	93	470

Input Specifications			
Input voltage	B78C03-2R0-R1	12V nominal input	4.75-36V
	B78C05-2R0-R1	12V nominal input	6.5-36V
	B78C12-2R0-R1	24V nominal input	15-36V
Input filter			Capacitor type
Input Reverse Polarity	None, install external fuse(2A Fast blow)		
No Load Input Current			10mA Typ.
Hot swap is not supported			
Environmental Specifications			
Operating ambient temperature	-40°C to +85°C (with derating)		
Storage temperature range	-55°C to +125°C		
Relative humidity	5% TO 95% RH max.		
Temperature coefficient	±0.02% / °C Typ.		
RoHS Compliant	RoHS 2.0		
Output Specifications			
Output current			2A max.
Voltage accuracy	At 50% load	-4% Min.	
		+4% Max.	
Minimum load	(No minimum load)	0mA	
Line regulation	Vin=min. to max. Vout=nom.	±0.4% Typ	
		±0.8% max.	
Load Regulation	10 -100% load	±0.5% Typ	
		±1.5% max	
Ripple and Noise (20MHz Bandwidth)	75mVp-p max.		
Capacitive load	2200uS max		
Over Current Protection(OCP)	100%=1A	200% Typ	
		250% max	
Short Circuit Protection(SCP)	Continuous, autorecovery		
General Specifications			
Efficiency			See table
Switching frequency (Fixed)	Pulse width modulation (PWM)		410kHz Typ
Dynamic load response	75-100-75% 25%load step		100uS Typ
Reliability, calculated MTBF	B78C03-2R0/ B78C05-2R0		2.0×10 ⁶ Hrs
Safety ⁽⁵⁾	UL-60950-1,IEC/EN60950-1,2nd Edition		meet
Physical Specifications			
Dimensions	0.45 × 0.33 × 0.68 Inch (11.6 × 8.5 × 17.5 mm)		
Weight	4g (0.142oz) typ.		

Efficiency Curve

B78C03-2R0-R1

Efficiency vs Line Voltage and Load Current@+25°C(Vout=Vnom.)

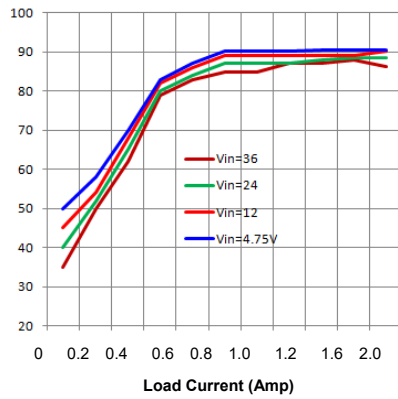

B78C05-2R0-R1

Efficiency vs Line Voltage and Load Current@+25°C(Vout=Vnom.)

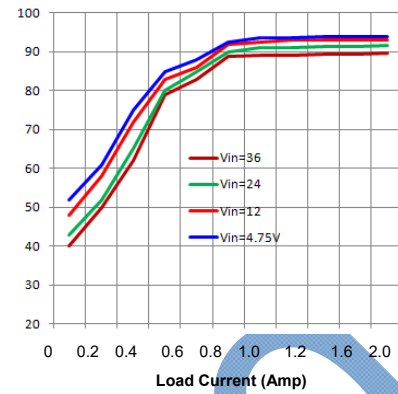

Power Derating Curve

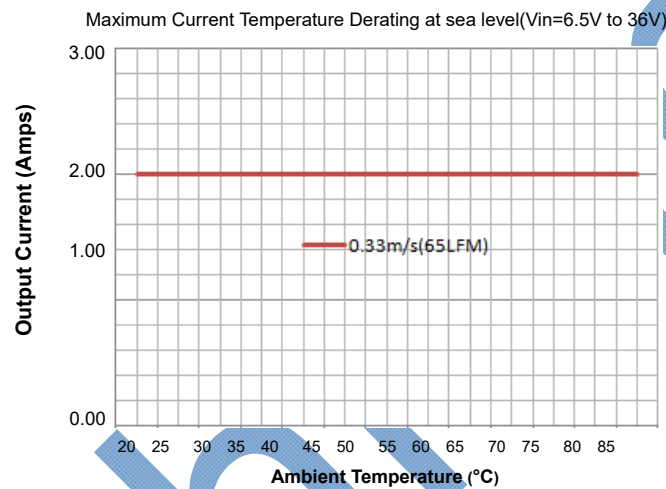

Note

1. Io below this value will not damage these converters, however, they may not meet all listed specifications.
2. Typical value, tested at nominal input and full load.
3. Specifications subject to change without notice.
4. This power module is not internally fused. The input line fuse must always be used.
5. Input Back Ripple Current is tested and specified over a 5 Hz to 20 MHz bandwidth.
Input filtering is Cin=2x 100 uF, Cbus=1000 uF, Lbus=1 uH. All caps are low ESR types.

Mechanical Dimensions

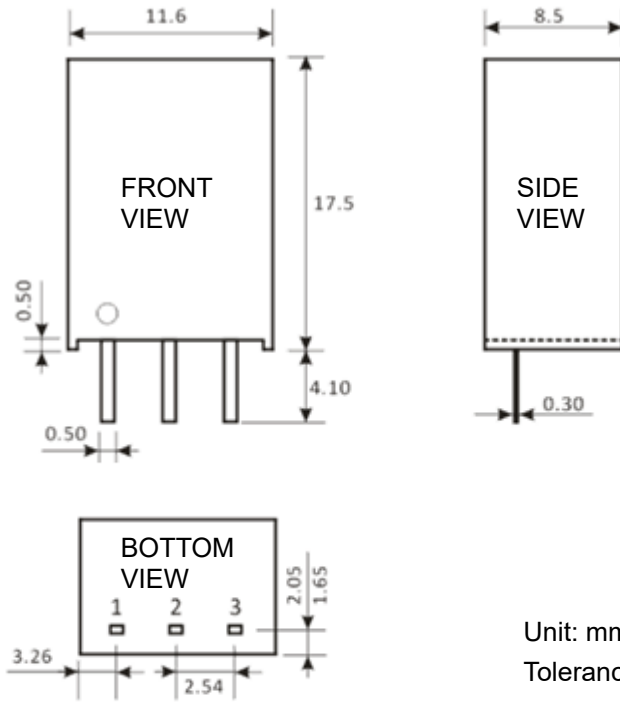

Pin Assignment	
Pin	Define
1	Positive Input
2	Common(Ground)
3	Positive Output

Unit: mm
Tolerance: XX.X=±0.5, XX.XX=±0.25

Package Information

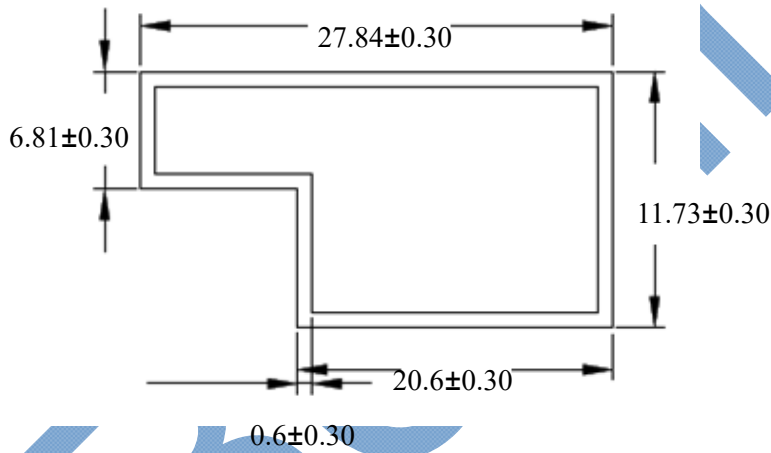

PS:
Unit: mm [inch]
L= 220 mm[8.66 inch] ; ONE TUBE = 16 PCS

The components used in the above figure, together with the manufacturers' part numbers for these components, are as follows:

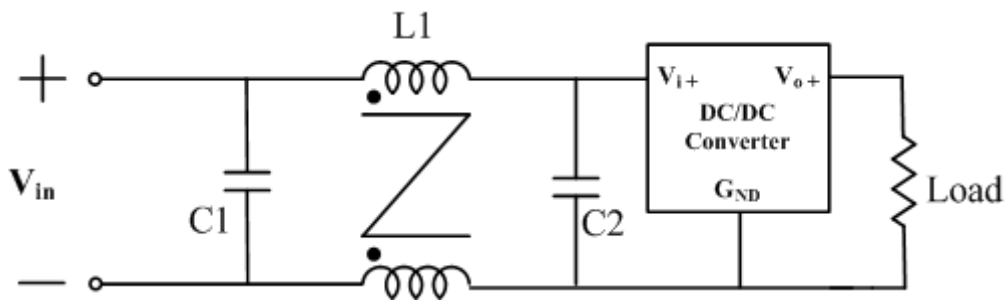

Models	C1	C2	L1
B78C03-2R0-R1 B78C05-2R0-R1	10uF/50V MLCC	10uF/50V MLCC	PCM090704S-701 SMD Common mode choke
B78C12-2R0-R1	10uF/50V MLCC	10uF/50V MLCC	PCM090704S-102 SMD Common mode choke

The components used in the above figure, together with the manufacturers' part numbers for these components, are as follows:

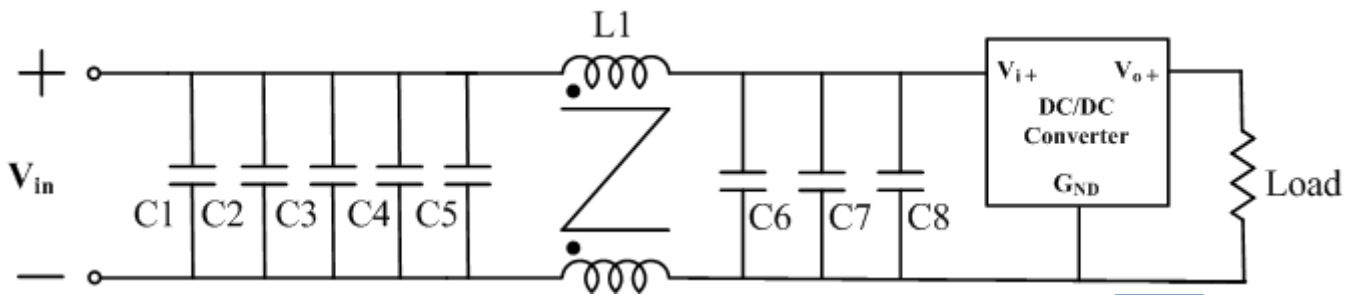

Models	C1	C2,C3	C4,C5	C6	C7,C8,C9	L1
B78C03-2R0-R1 B78C05-2R0-R1	100uF/50V Aluminum electrolytic solid capacitors	10uF/50V MLCC	N/A	100uF/50V Aluminum electrolytic solid capacitors	10uF/50V MLCC	PCM090704S-701 SMD Common mode choke
B78C12-2R0-R1	100uF/50V Aluminum electrolytic solid capacitors	100uF/50V Aluminum electrolytic solid capacitors	10uF/50V MLCC	100uF/50V Aluminum electrolytic solid capacitors	10uF/50V MLCC	PCM090704S-102 SMD Common mode choke

Test Configurations

All specifications are typical at nominal input, full load and 25°C unless otherwise stated.

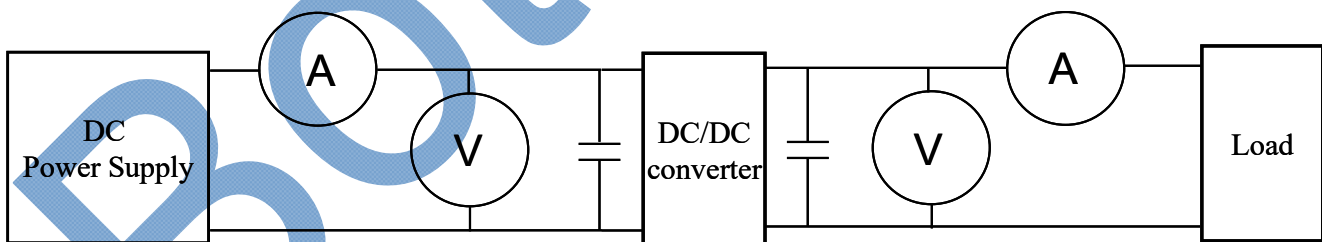

- ⊙DC Power Supply: It offers a wide voltage and current range precisely.
- ⊙Current meter (A): Accuracy → 200μA ~ 200mA 4 ranges+(0.2% rdg + 2 digits)
2000mA ~ 20A 2 ranges+(0.3% rdg + 2 digits).
- ⊙Voltage meter (V): Accuracy → ±(0.03% rdg + 4 digits).
- ⊙Load: At full load.
- ⊙Wires: The resistance of the wires must be small.

1. Ripple and Noise: as shown below. The bandwidth is 0-20MHz.

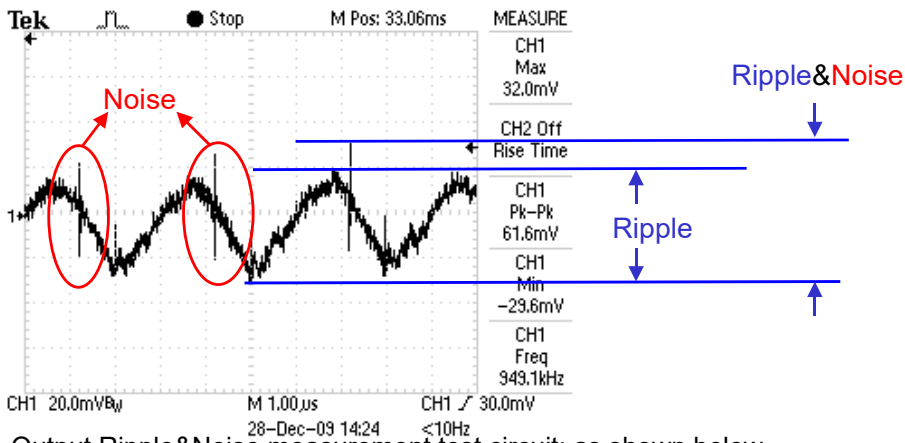

Output Ripple&Noise measurement test circuit: as shown below.

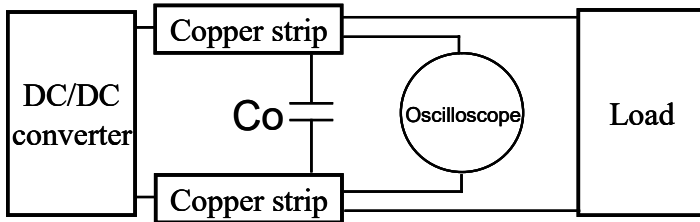

Co: usually 10uF to 47uF use low-ESR ceramic.

2. **Temperature derating curve:** The DC-DC converter will operate over a wider temperature range if less power is drawn from the output and the device is already running. The temperature derating curve shows the operating power-temperature range. As shown below.

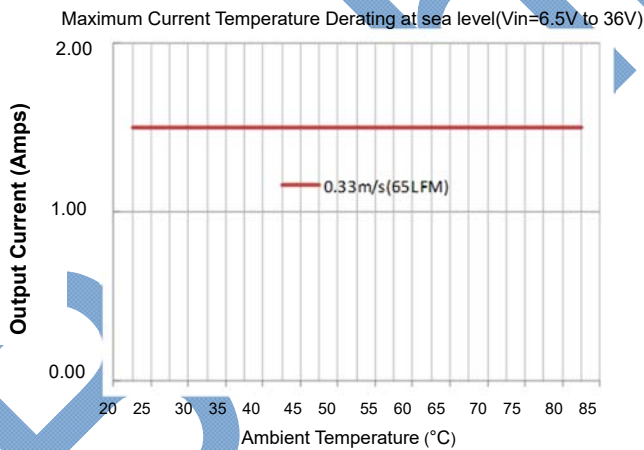

3. **Application circuit:** as shown below. C1=100uF/50V, C2 =47uF/16V MLCC.

