

Current1A High Voltage40V Low Power LDO

SSP7903

General Description

The SSP7903 series is a group of positive voltage output, three-pin regulators, that provide a high current even when the input/output voltage differential is small. Low power consumption and high accuracy is achieved through CMOS and laser trimming technologies.

The SSP7903 consists of a high-precision voltage reference, an error amplification circuit, and a current limited output driver. Transient response to load variations have improved in comparison to the existing series.



Features

- Low Quiescent Current: 1.6 μ A
- Temperature Stability: ± 50 ppm/ $^{\circ}$ C
- High input voltage: 40V
- Output voltage accuracy: tolerance $\pm 2\%$
- Low temperature coefficient
- Dropout Voltage: 20mV@IOUT=10mA
- Large Output Current: 1A
- Packages: SOT89-3L, SOT223 and TO252

Applications

- Industrial control
- Smart meters, instruments and meters
- Battery supply set
- Wireless communication equipment
- Automotive electronics

Order information

Product model	Package	Manner of packing	Minimum packing quantity
SSP7903Pxxxx	SOT89-3L	reel	1000
	SOT223		2500
	TO252	Tube	2500

Selection Guide Table

SSP7903P①②③④

Designator	Symbol	Description
① ②	Integer	Output Voltage(3.0V~12.0V)
③	P	Package:SOT89-3L
	F	Package:SOT223
	J	Package: TO252
④	R	RoHS / Pb Free
	G	Halogen Free

Note: "① ②" stands for output voltages. Other voltages can be specially customized.

Part No.	Output Voltage	Package	Marking
SSP7903P30PR	3.0V	SOT89-3L	XXXX
SSP7903P33PR	3.3V	SOT89-3L	XXXX
SSP7903P36PR	3.6V	SOT89-3L	XXXX
SSP7903P40PR	4.0V	SOT89-3L	XXXX
SSP7903P50PR	5.0V	SOT89-3L	XXXX
SSP7903P12PR	12.0V	SOT89-3L	XXXX
SSP7903P30FR	3.0V	SOT223	XXXX
SSP7903P33FR	3.3V	SOT223	XXXX
SSP7903P36FR	3.6V	SOT223	XXXX
SSP7903P40FR	4.0V	SOT223	XXXX

SSP7903P50FR	5.0V	SOT223	XXXX
SSP7903P12FR	12.0V	SOT223	XXXX
SSP7903P30JR	3.0V	TO252	XXXX
SSP7903P33JR	3.3V	TO252	XXXX
SSP7903P36JR	3.6V	TO252	XXXX
SSP7903P40JR	4.0V	TO252	XXXX
SSP7903P50JR	5.0V	TO252	XXXX
SSP7903P12JR	12.0V	TO252	XXXX

Functional Block Diagram

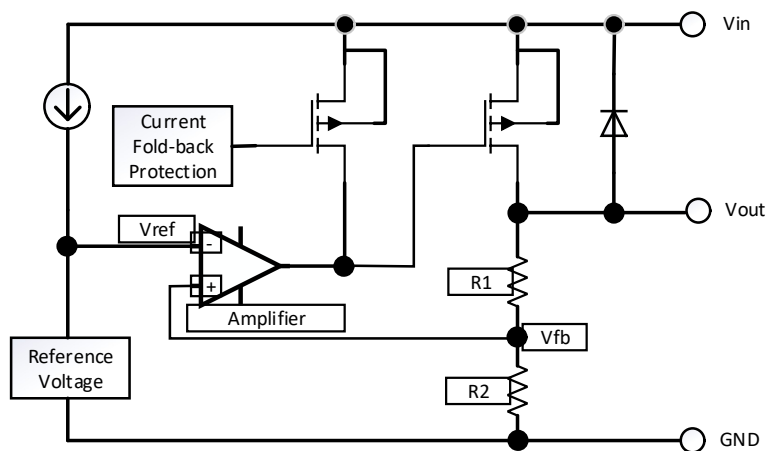

Pin Assignment (TOP VIEW)

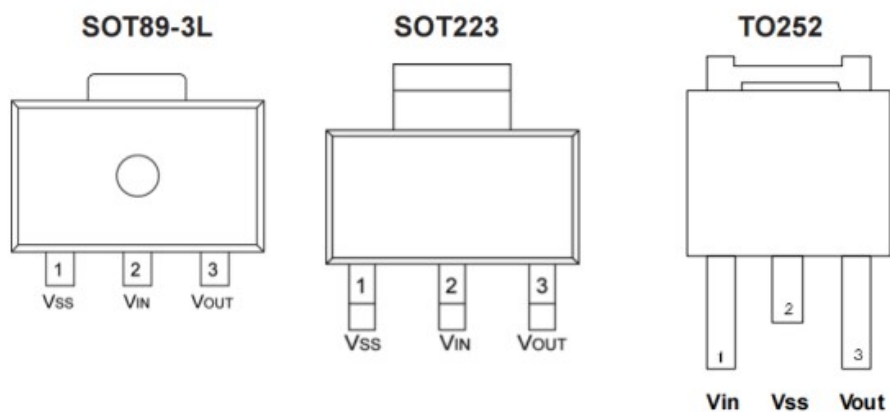

Application Circuits

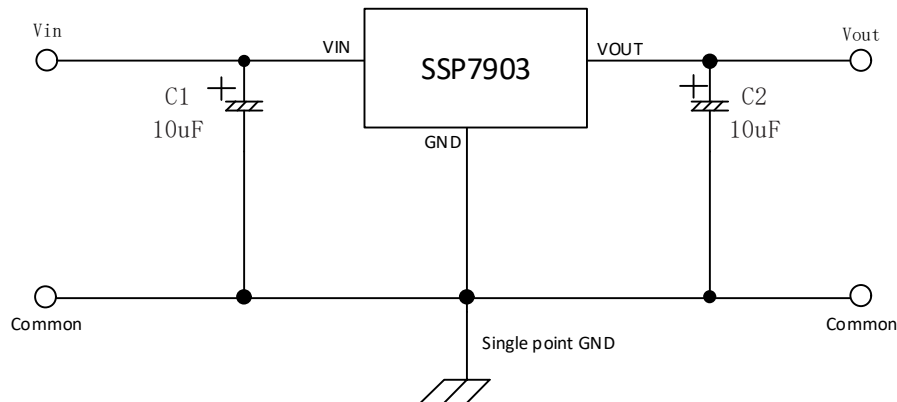

Absolute Maximum Ratings

(Unless otherwise indicated: $T_a=25^{\circ}\text{C}$)

PARAMETER	SYMBOL	MIN	MAX	UNITS
Input Voltage	V_{IN}	-0.3	40	V
Output Voltage	V_{OUT}	$V_{SS}-0.3$	$V_{IN}+0.3V$	
Power Dissipation	P_D (1)		SOT 89 1000 TO 252 1800 SOT 223 1500	mW
Operating Ambient Temperature	T_{opr}	-40	85	$^{\circ}\text{C}$
Storage Temperature	T_{stg}	-40	125	
ESD Protection	ESD HBM		2000	V

Note: These are just the limit parameters. Beyond the range specified in the Absolute Maximum Ratings may cause serious damage to the equipment. Long exposure to extreme conditions may affect the reliability of the device.

(1) Increasing the welding area of package is beneficial to increase power consumption

Electrical Characteristics

 SSP7903 Series (Unless otherwise indicated: $T_a=25^{\circ}\text{C}$)

PARAMETER	SYMBOL	CONDITIONS	MIN	TYP	MAX	UNIT	
Output Voltage ¹	$V_{OUT(S)}$	$V_{IN}=V_{OUT(S)}+2V, I_{OUT}=10\text{mA}$	$V_{OUT(S)} \times 0.98$	$V_{OUT(S)}$	$V_{OUT(S)} \times 1.02$	V	
Dropout Voltage ²	V_{DROP}	$I_{OUT}=1\text{mA}$		4	8	mV	
		$I_{OUT}=1\text{A}$		1000	1500		
Line Regulation	$\frac{\Delta V_{OUT}}{\Delta V_{IN} \times V_{OUT}}$	$V_{OUT(S)}+2V \leq V_{IN} \leq 40V$ $I_{OUT}=1\text{mA}$		0.01	0.02	%/V	
Load Regulation	ΔV_{OUT2}	$V_{IN}=V_{OUT(S)}+2V$ $V_{OUT(S)} \leq 10V$		20	80	mV	
		$1\text{mA} \leq I_{OUT} \leq 300\text{mA}$ $V_{OUT(S)} > 10V$		85	150		
Temperature Stability	$\frac{\Delta V_{OUT}}{\Delta T_a}$	$V_{IN}=V_{OUT(S)}+2V, I_{OUT}=10\text{mA}$ $-40^{\circ}\text{C} \leq T_a \leq 85^{\circ}\text{C}$		± 50		ppm/ $^{\circ}\text{C}$	
GND Current	I_{GND}	no load	$V_{OUT(S)} < 3.0V$	0.8	1.2	2	μA
			$3.0 \leq V_{OUT(S)} \leq 40V$	1	1.6	3	
		$I_{OUT}=100\text{mA}$		370			
Input Voltage	V_{IN}	---	2.2		40	V	
Maximum Output Current	I_{OUTMAX}				1	A	
Current Limit ³	I_{LIM}	$V_{IN}=V_{OUT(S)}+2V,$ $V_{OUT}=0.9 \times V_{OUT(S)}$		1.8		A	
Short Circuit Current	I_{SHORT}	$V_{IN}=V_{OUT(S)}+2V, V_{OUT}=0V$		120		mA	
Power Supply Rejection Ratio	PSRR	$f=10\text{Hz}, V_{OUT(S)}=3.6V$		73.2		dB	
		$f=100\text{Hz}, V_{OUT(S)}=3.6V$		72.2			
		$f=1\text{kHz}, V_{OUT(S)}=3.6V$		54.5			
Over Temperature Protection	OTP	$I_{OUT}=10\text{mA}$		145		$^{\circ}\text{C}$	

Notes:

- $V_{OUT(S)}$: Output voltage when $V_{IN}=V_{out}+2V, I_{out}=1\text{mA}$.
- $V_{DROP}=V_{in1} - (V_{out(S)} \times 0.98)$ where V_{in1} is the input voltage when $V_{out} = V_{out(S)} \times 0.98$.
- I_{LIM} : Output current when $V_{in}=V_{out(S)}+2V$ and $V_{out} = 0.95 \times V_{out(S)}$.

Typical Performance Characteristics

Test Conditions: SSP7903P36 $C_{IN}=4.7\mu F$, $C_{OUT}=4.7\mu F$, unless otherwise indicated.

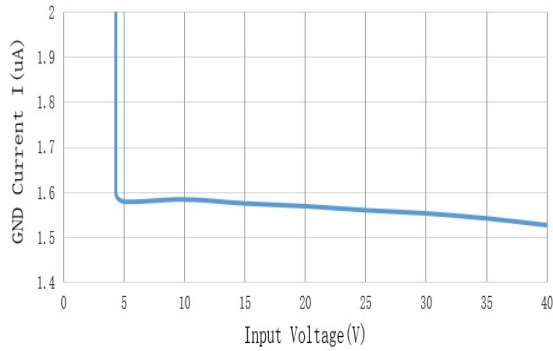

GND Current vs Input Voltage
SSP7903P36

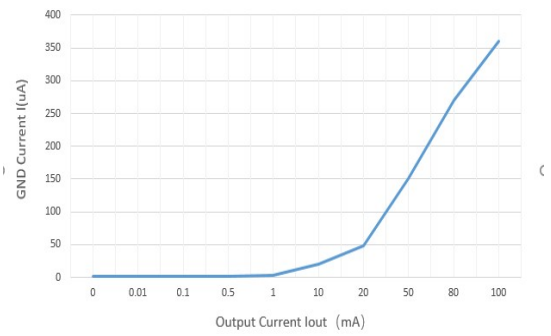

GND Current vs Output Current
SSP7903P36

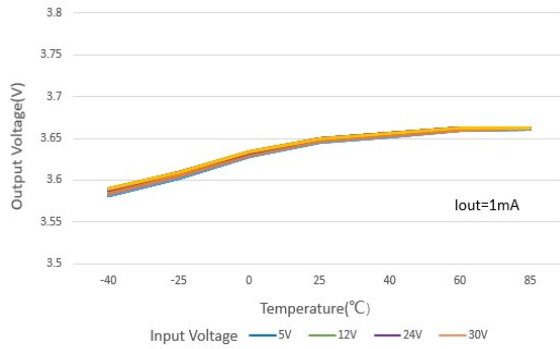

V_{OUT} vs Temperature
SSP7903P36

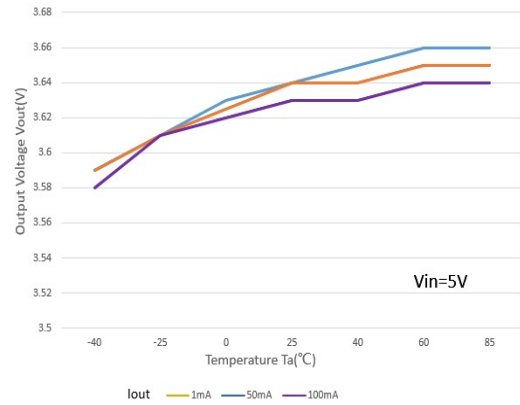

V_{OUT} vs Temperature
SSP7903P36

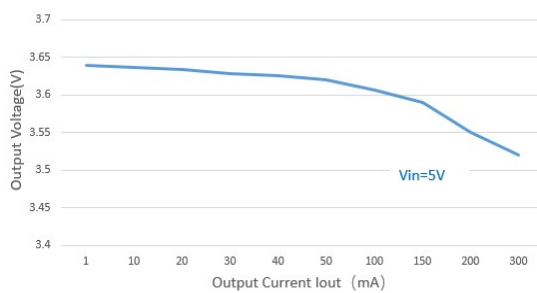

V_{OUT} vs Current out
SSP7903P36

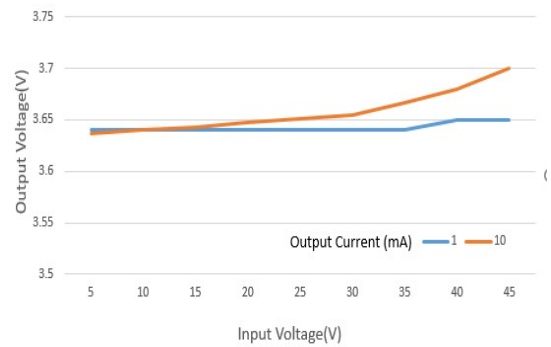

V_{OUT} vs Input Voltage
SSP7903P36

Typical Performance Characteristics

Test Conditions: $V_{IN}=V_{OUT}+2.0V$, $C_{IN}=2.2\mu F$, $C_{OUT}=2.2\mu F$, unless otherwise indicated.

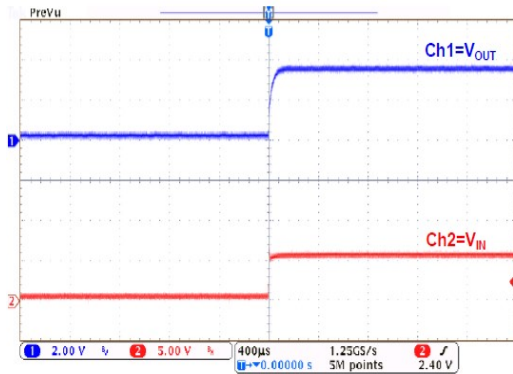

Power-Up at $V_{OUT}=3.6V$ SSP7903P36
($I_{OUT}=0mA$)

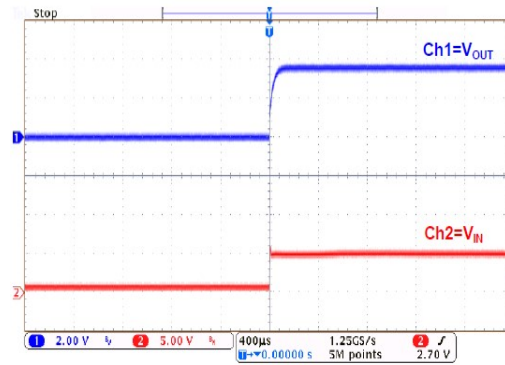

Power-Up at $V_{OUT}=3.6V$ SSP7903P36
($I_{OUT}=1A$)

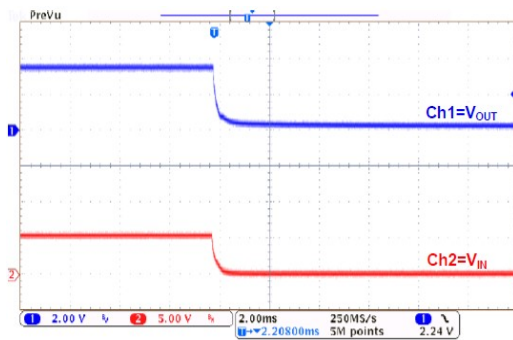

Power- Down at $V_{OUT}=3.6V$ SSP7903P36
($I_{OUT}=0mA$)

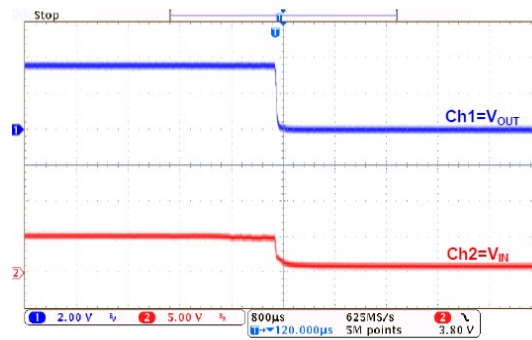

Power- Down at $V_{OUT}=3.6V$ SSP7903P36
($I_{OUT}=1A$)

Package Information

SOT89-3L Package Outline Dimensions

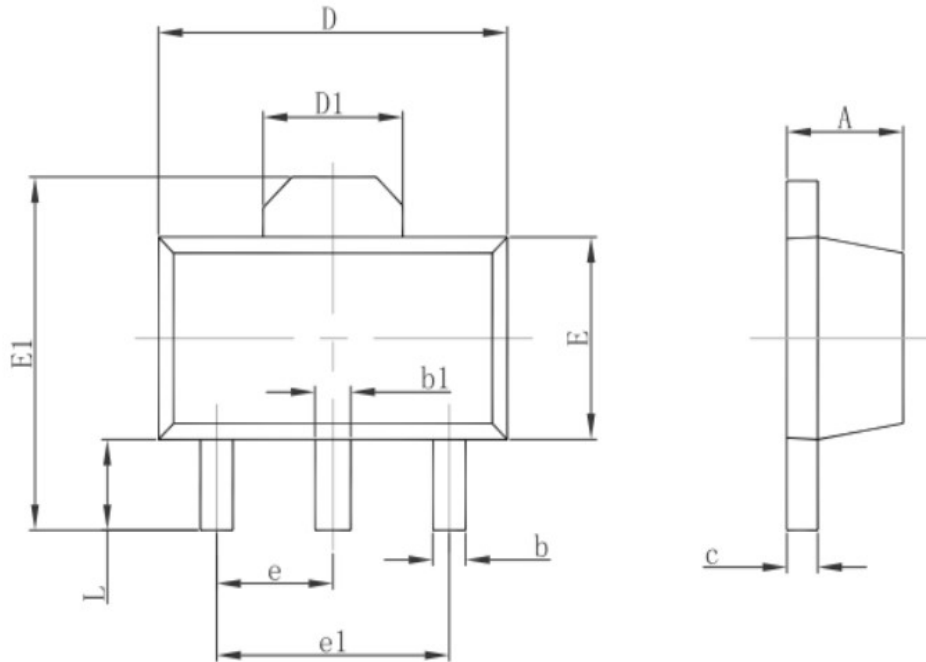

Symbol	Dimensions In Millimeters		Dimensions In Inches	
	Min	Max	Min	Max
A	1.400	1.600	0.055	0.063
b	0.320	0.520	0.013	0.020
b1	0.400	0.580	0.016	0.023
c	0.350	0.440	0.014	0.017
D	4.400	4.600	0.173	0.181
D1	1.550 REF		0.061 REF	
E	2.300	2.600	0.091	0.102
E1	3.940	4.250	0.155	0.167
e	1.500 TYP		0.060 TYP	
e1	3.000 TYP		0.118 TYP	
L	0.900	1.200	0.035	0.047

SOT223 Package Outline Dimensions

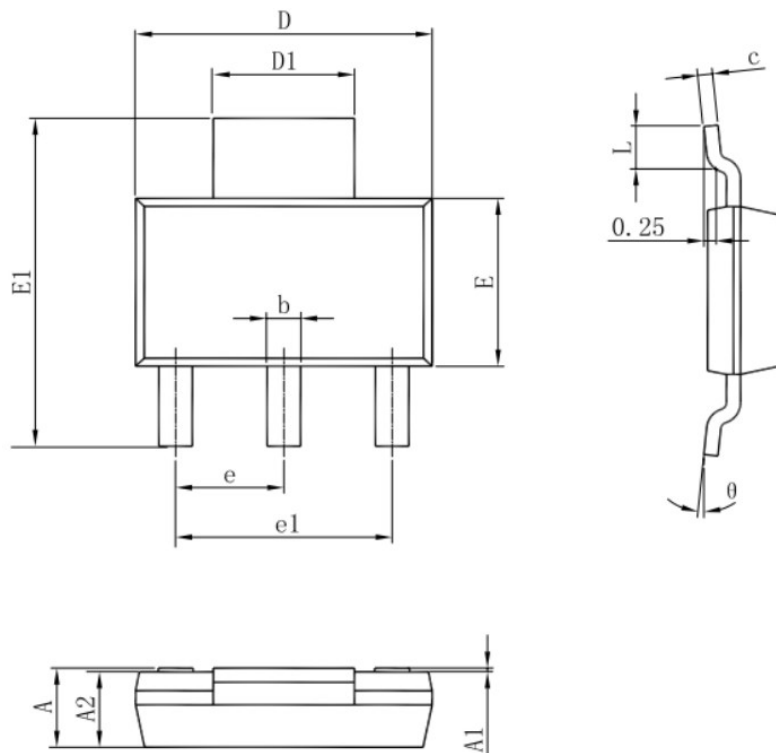

Symbol	Dimensions In Millimeters		Dimensions In Inches	
	Min	Max	Min	Max
A	1.520	1.800	0.060	0.071
A1	0.000	0.100	0.000	0.004
A2	1.500	1.700	0.059	0.067
b	0.660	0.820	0.026	0.032
c	0.250	0.350	0.010	0.014
D	6.200	6.400	0.244	0.252
D1	2.900	3.100	0.114	0.122
E	3.300	3.700	0.130	0.146
E1	6.830	7.070	0.269	0.278
e	2.300(BSC)		0.091(BSC)	
e1	4.500	4.700	0.177	0.185
L	0.900	1.150	0.035	0.045
θ	0°	10°	0°	10°

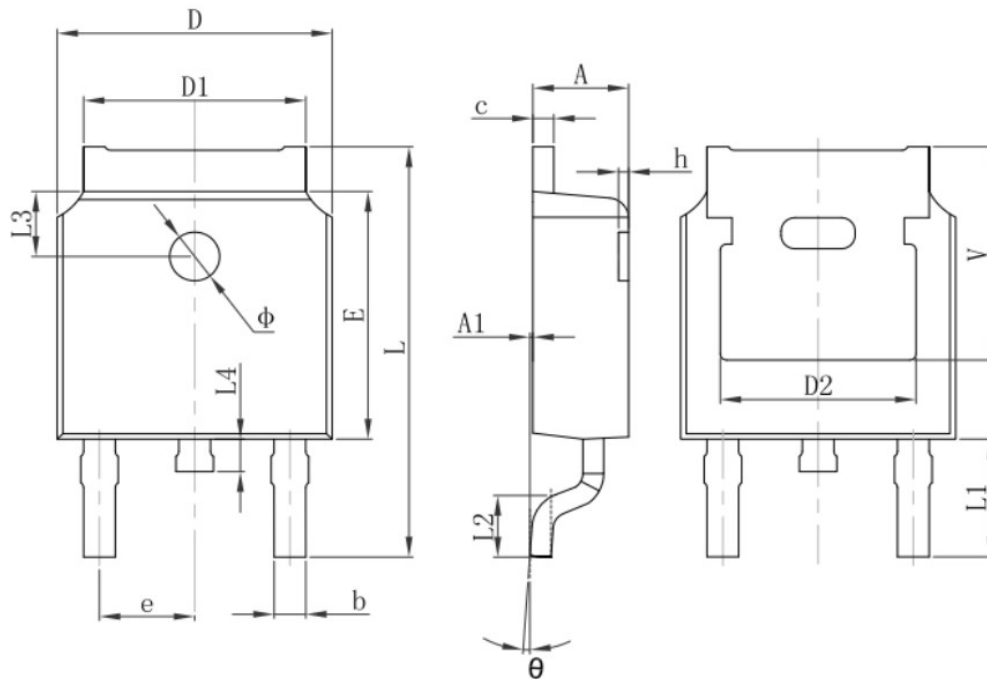
TO252 Package Outline Dimensions

Symbol	Dimensions In Millimeters		Dimensions In Inches	
	Min	Max	Min	Max
A	2.200	2.400	0.087	0.094
A1	0.000	0.127	0.000	0.005
b	0.660	0.860	0.026	0.034
c	0.460	0.580	0.018	0.023
D	6.500	6.700	0.256	0.264
D1	5.100	5.460	0.201	0.215
D2	4.830 REF		0.190 REF	
E	6.000	6.200	0.236	0.244
e	2.186	2.386	0.086	0.094
L	9.800	10.400	0.386	0.409
L1	2.900 REF		0.114 REF	
L2	1.400	1.700	0.055	0.067
L3	1.600 REF		0.063 REF	
L4	0.600	1.000	0.024	0.039
Φ	1.100	1.300	0.043	0.051
θ	0°	8°	0°	8°
h	0.000	0.300	0.000	0.012
V	5.350 REF		0.211 REF	

Special Version

The company reserves the right of final interpretation of this specification.

Version Change Description

Versions: V1.2

Writer: Si Yuan Wu

Time: 2021.10.29