

## Dual P-Channel Enhancement Mode MOSFET

### Features

- 30V/-4.9A ,  
 $R_{DS(ON)} = 53m\Omega (typ.) @ V_{GS} = -10V$   
 $R_{DS(ON)} = 80m\Omega (typ.) @ V_{GS} = -4.5V$
- Reliable and Rugged
- Lead Free and Green Device Available  
(RoHS Compliant)

### Applications

- Power Management in Notebook Computer, Portable Equipment and Battery Powered Systems

### Pin Description

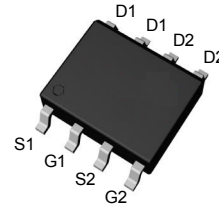

Top View of SOP-8

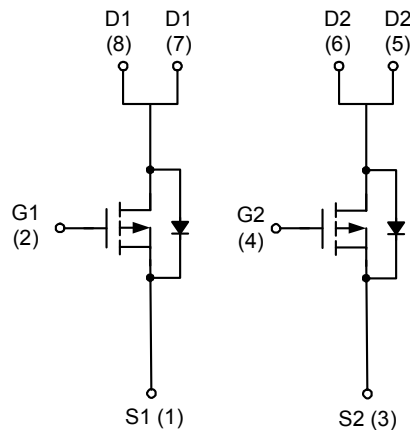

P-Channel MOSFET

### Ordering and Marking Information

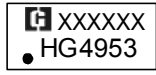
<p>HG4953    □□-□□□</p> <p>└─ Assembly Material  └─ Handling Code  └─ Temp. Range  └─ Package Code</p>	<p>Package Code K : SOP-8</p> <p>Operating Junction Temp. Range C : -55 to 150 °C</p> <p>Handling Code TR : Tape &amp; Reel (2500ea/reel)</p> <p>Assembly Material L : Lead Free Device G : Halogen and Lead Free Device</p>
<p>HG4953 :    </p>	<p>XXXXXX - Lot Code</p>

Note : SINOPOWER lead-free products contain molding compounds/die attach materials and 100% matte tin plate termination finish; which are fully compliant with RoHS. SINOPOWER lead-free products meet or exceed the lead-free requirements of IPC/JEDEC J-STD-020C for MSL classification at lead-free peak reflow temperature. SINOPOWER defines "Green" to mean lead-free (RoHS compliant) and halogen free (Br or Cl does not exceed 900ppm by weight in homogeneous material and total of Br and Cl does not exceed 1500ppm by weight).

SINOPOWER reserves the right to make changes to improve reliability or manufacturability without notice, and advise customers to obtain the latest version of relevant information to verify before placing orders.

## Absolute Maximum Ratings (T<sub>A</sub> = 25°C unless otherwise noted)

Symbol	Parameter	Rating	Unit	
V <sub>DSS</sub>	Drain-Source Voltage	-30	V	
V <sub>GSS</sub>	Gate-Source Voltage	±25		
I <sub>D</sub> <sup>*</sup>	Continuous Drain Current	-4.9	A	
I <sub>DM</sub> <sup>*</sup>	Pulsed Drain Current			-20
I <sub>S</sub> <sup>*</sup>	Diode Continuous Forward Current	-2	A	
T <sub>J</sub>	Maximum Junction Temperature	150	°C	
T <sub>STG</sub>	Storage Temperature Range	-55 to 150		
P <sub>D</sub> <sup>*</sup>	Power Dissipation for Single Operation	T <sub>A</sub> =25°C	2	W
		T <sub>A</sub> =100°C	0.8	
R <sub>θJA</sub> <sup>*</sup>	Thermal Resistance-Junction to Ambient	62.5	°C/W	

\*Note:

\*Surface Mounted on 1in<sup>2</sup> pad area, t ≤ 10sec.

## Electrical Characteristics (T<sub>A</sub> = 25°C unless otherwise noted)

Symbol	Parameter	Test Condition	SM4953K			Unit
			Min.	Typ.	Max.	
<b>Static Characteristics</b>						
BV <sub>DSS</sub>	Drain-Source Breakdown Voltage	V <sub>GS</sub> =0V, I <sub>DS</sub> =250μA	-30			V
I <sub>DSS</sub>	Zero Gate Voltage Drain Current	V <sub>DS</sub> =-24V, V <sub>GS</sub> =0V T <sub>J</sub> =85°C			-1	μA
					-30	
V <sub>GS(th)</sub>	Gate Threshold Voltage	V <sub>DS</sub> =V <sub>GS</sub> , I <sub>DS</sub> =250μA	-1	-1.5	-2	V
I <sub>GSS</sub>	Gate Leakage Current	V <sub>GS</sub> =±25V, V <sub>DS</sub> =0V			±100	nA
R <sub>DS(on)</sub> <sup>a</sup>	Drain-Source On-state Resistance	V <sub>GS</sub> =-10V, I <sub>DS</sub> =-4.9A		53	60	mΩ
		V <sub>GS</sub> =-4.5V, I <sub>DS</sub> =-3.6A		80	95	
V <sub>SD</sub> <sup>a</sup>	Diode Forward Voltage	I <sub>SD</sub> =-1.7A, V <sub>GS</sub> =0V		-0.8	-1.3	V
<b>Gate Charge Characteristics<sup>b</sup></b>						
Q <sub>g</sub>	Total Gate Charge	V <sub>DS</sub> =-15V, V <sub>GS</sub> =-10V, I <sub>DS</sub> =-4.9A		11.6	16	nC
Q <sub>gs</sub>	Gate-Source Charge			1.3		
Q <sub>gd</sub>	Gate-Drain Charge			2.5		

## Electrical Characteristics (Cont.) (T<sub>A</sub> = 25°C unless otherwise noted)

Symbol	Parameter	Test Condition	SM4953K			Unit
			Min.	Typ.	Max.	
<b>Dynamic Characteristics</b> <sup>b</sup>						
R <sub>G</sub>	Gate Resistance	V <sub>GS</sub> =0V, V <sub>DS</sub> =0V, F=1MHz		8		Ω
C <sub>ISS</sub>	Input Capacitance	V <sub>GS</sub> =0V, V <sub>DS</sub> =-15V, Frequency=1.0MHz		625		pF
C <sub>OSS</sub>	Output Capacitance			100		
C <sub>ISS</sub>	Reverse Transfer Capacitance			60		
t <sub>d(ON)</sub>	Turn-on Delay Time	V <sub>DD</sub> =-15V, R <sub>L</sub> =15Ω, I <sub>DS</sub> =-1A, V <sub>GEN</sub> =-10V, R <sub>G</sub> =6Ω		6	12	ns
t <sub>r</sub>	Turn-on Rise Time			12	23	
t <sub>d(OFF)</sub>	Turn-off Delay Time			25	46	
t <sub>f</sub>	Turn-off Fall Time			6	12	
t <sub>rr</sub>	Reverse Recovery Time	I <sub>DS</sub> =-4.9A,		14		ns
Q <sub>rr</sub>	Reverse Recovery Charge	di <sub>SD</sub> /dt=100A/μs		5		nC

Notes:

- a : Pulse test ; pulse width ≤ 300μs, duty cycle ≤ 2%.
- b : Guaranteed by design, not subject to production testing.

**Typical Characteristics**

**Power Dissipation**

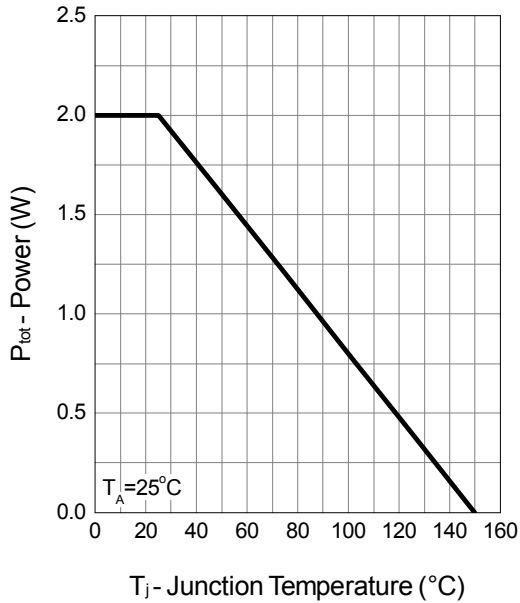

**Drain Current**

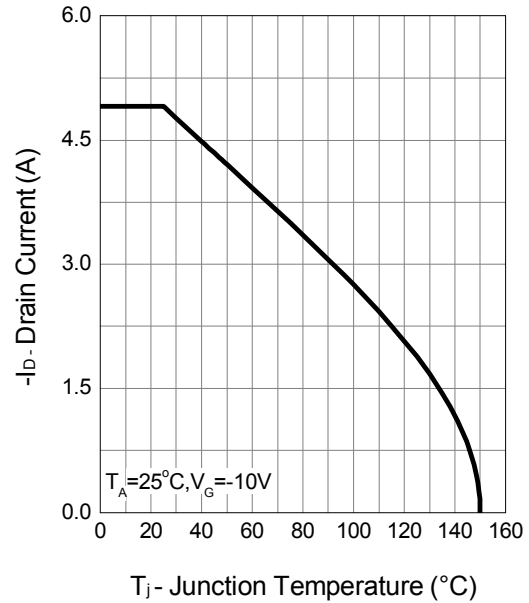

**Safe Operation Area**

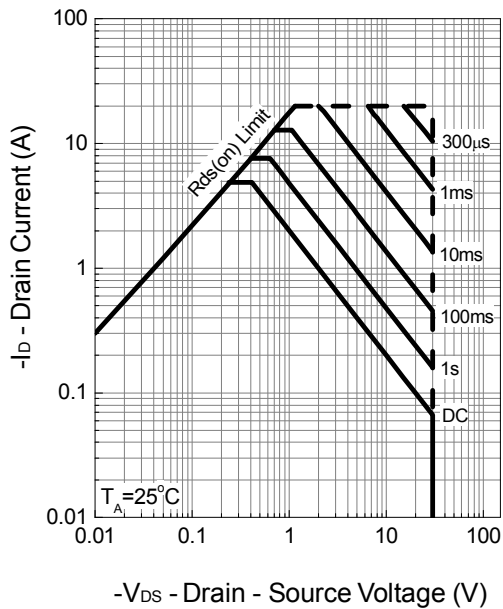

**Thermal Transient Impedance**

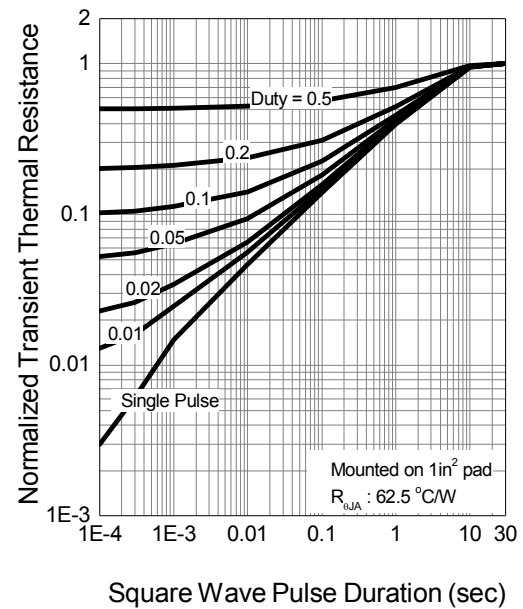

**Typical Characteristics (Cont.)**

**Output Characteristics**

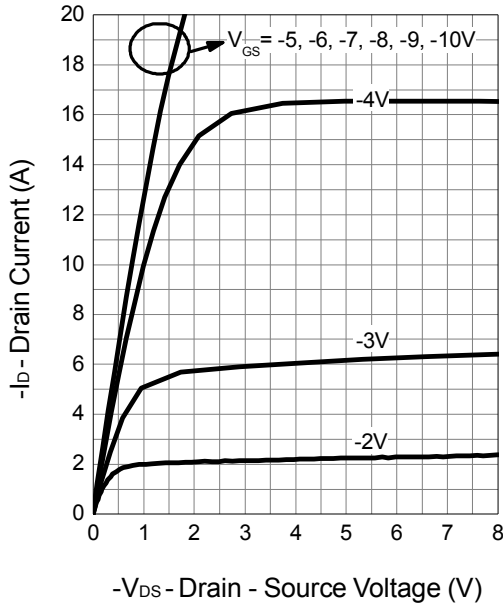

**Drain-Source On Resistance**

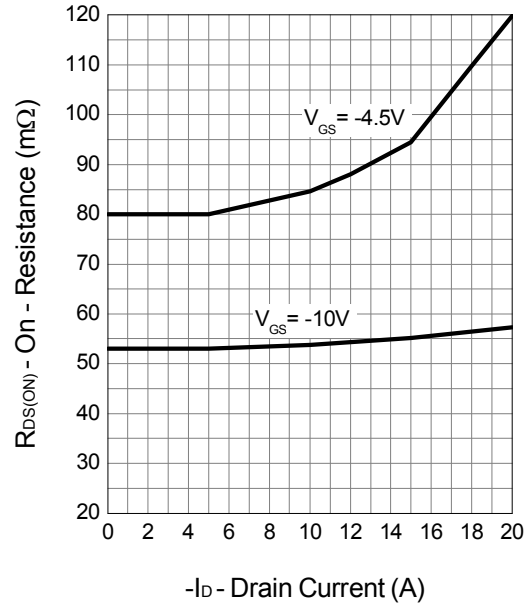

**Drain-Source On Resistance**

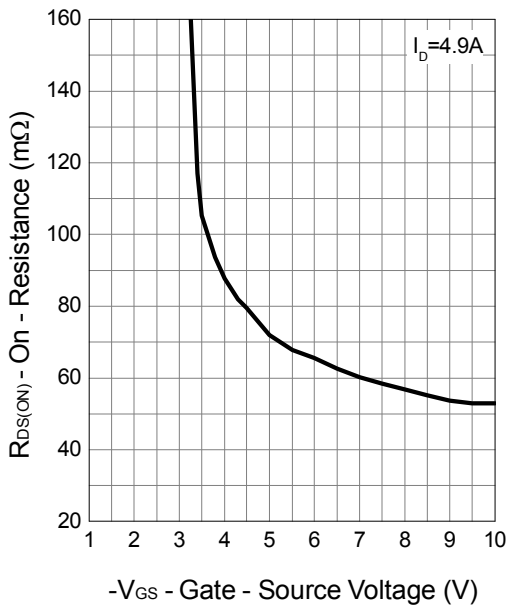

**Gate Threshold Voltage**

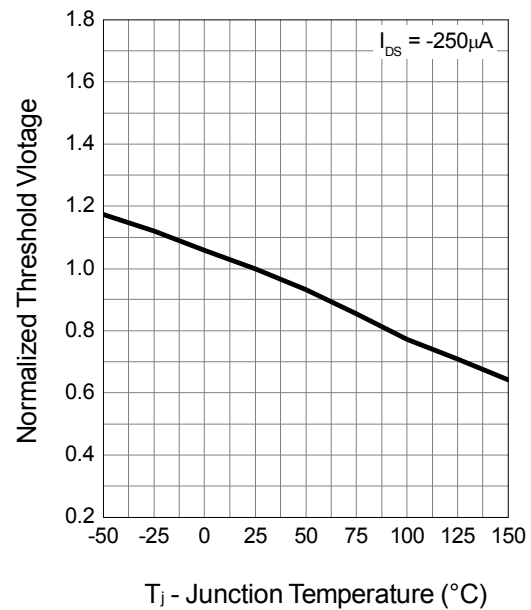

**Typical Characteristics (Cont.)**

**Drain-Source On Resistance**

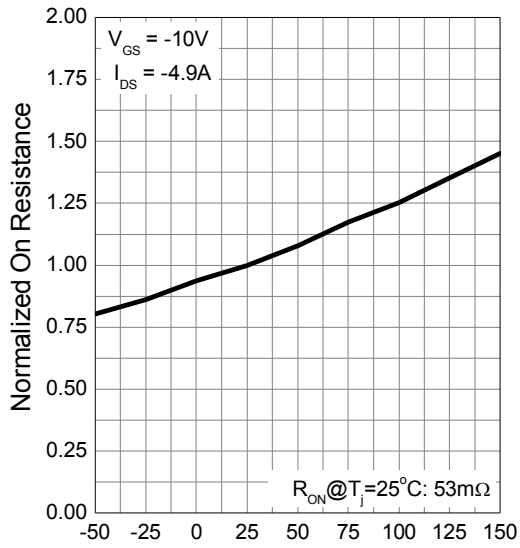

$T_j$  - Junction Temperature (°C)

**Source-Drain Diode Forward**

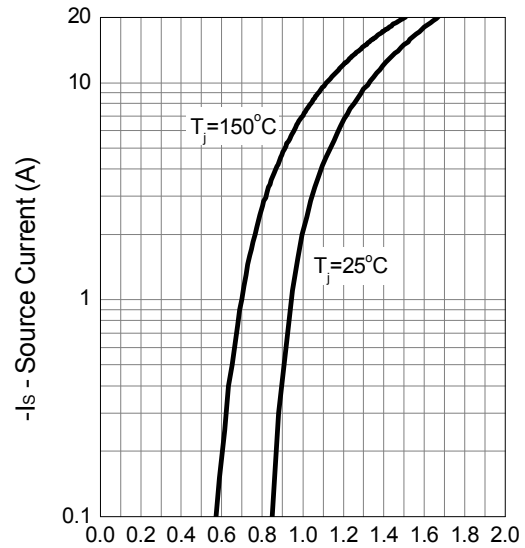

$-V_{SD}$  - Source-Drain Voltage (V)

**Capacitance**

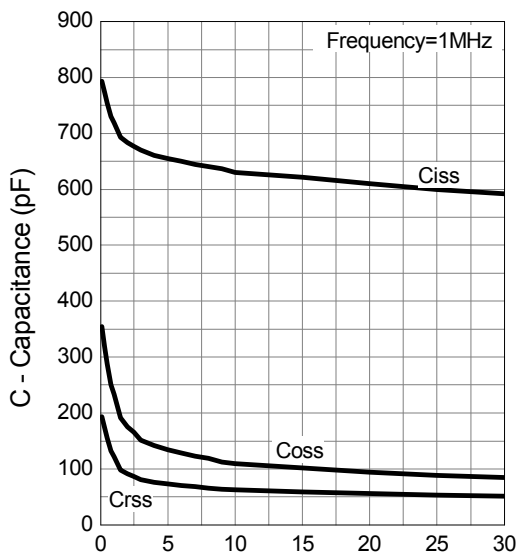

$-V_{DS}$  - Drain-Source Voltage (V)

**Gate Charge**

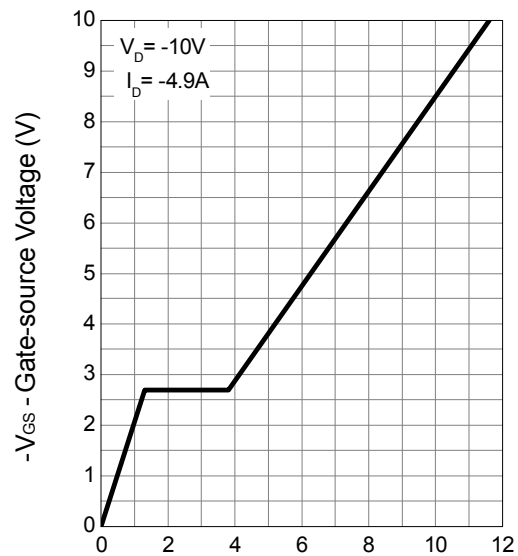

$Q_G$  - Gate Charge (nC)

### Avalanche Test Circuit and Waveforms

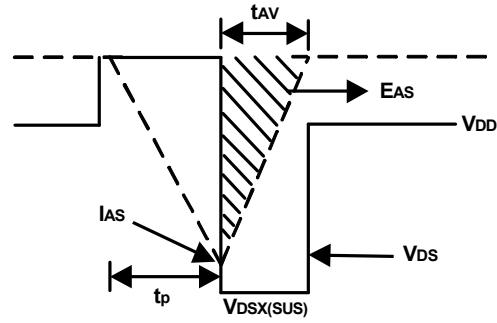
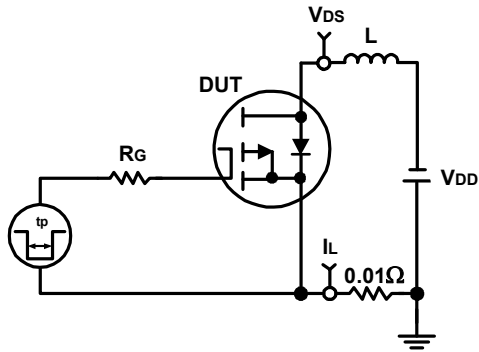

### Switching Time Test Circuit and Waveforms

