

ZT シリーズ
SERIES

125°C 低インピーダンス品
125°C Low Impedance

・125°C 1000~4000時間品。
Load Life : 125°C 1000~4000 hours.

RoHS
compliance



◆規格表 / SPECIFICATIONS

項目 Items	特性 Characteristics																				
カテゴリ温度範囲 Category Temperature Range	-40~+125°C																				
定格電圧範囲 Rated Voltage Range	10~35Vdc																				
静電容量許容差 Capacitance Tolerance	±20%(20°C,120Hz)																				
漏れ電流 Leakage Current(MAX)	I=0.03CV又は3µAのいずれか大なる値以下(定格電圧印加2分後) I=0.03CV or 3µA whichever is greater. (After 2 minutes) I=漏れ電流(µA) Leakage Current C=静電容量(µF) Capacitance V=定格電圧(Vdc) Rated Voltage																				
損失角の正接(tanδ) Dissipation Factor(MAX)	<table border="1"> <tr> <td>定格電圧(Vdc) Rated Voltage</td> <td>10</td> <td>16</td> <td>25</td> <td>35</td> <td>(20°C,120Hz)</td> </tr> <tr> <td>tanδ</td> <td>0.20</td> <td>0.16</td> <td>0.14</td> <td>0.12</td> <td></td> </tr> </table> <p>1000µFを越えるものは1000µF増す毎に上表の値に0.02を加えた値とする。 When capacitance is over 1000µF, tanδ shall be added 0.02 to the listed value with increase of every 1000µF.</p>	定格電圧(Vdc) Rated Voltage	10	16	25	35	(20°C,120Hz)	tanδ	0.20	0.16	0.14	0.12									
定格電圧(Vdc) Rated Voltage	10	16	25	35	(20°C,120Hz)																
tanδ	0.20	0.16	0.14	0.12																	
耐久性 Endurance	<p>125°C中で右表の時間定格電圧(リプル重畳)印加後、下記項目を満足すること。 After applying rated voltage with rated ripple current for specified time at 125°C, the capacitors shall meet the following requirements.</p> <table border="1"> <tr> <td>静電容量変化率 Capacitance Change</td> <td>初期値の±30%以内 Within ±30% of the initial value.</td> <td>ケースサイズ Case Size</td> <td>時間(hrs) Life Time</td> </tr> <tr> <td>損失角の正接 Dissipation Factor</td> <td>規格値の300%以下 Not more than 300% of the specified value.</td> <td>φD≤6.3</td> <td>1000</td> </tr> <tr> <td>漏れ電流 Leakage Current</td> <td>規格値以下 Not more than the specified value.</td> <td>φD=8</td> <td>2000</td> </tr> <tr> <td></td> <td></td> <td>φD=10</td> <td>3000</td> </tr> <tr> <td></td> <td></td> <td>φD=12.5</td> <td>4000</td> </tr> </table>	静電容量変化率 Capacitance Change	初期値の±30%以内 Within ±30% of the initial value.	ケースサイズ Case Size	時間(hrs) Life Time	損失角の正接 Dissipation Factor	規格値の300%以下 Not more than 300% of the specified value.	φD≤6.3	1000	漏れ電流 Leakage Current	規格値以下 Not more than the specified value.	φD=8	2000			φD=10	3000			φD=12.5	4000
静電容量変化率 Capacitance Change	初期値の±30%以内 Within ±30% of the initial value.	ケースサイズ Case Size	時間(hrs) Life Time																		
損失角の正接 Dissipation Factor	規格値の300%以下 Not more than 300% of the specified value.	φD≤6.3	1000																		
漏れ電流 Leakage Current	規格値以下 Not more than the specified value.	φD=8	2000																		
		φD=10	3000																		
		φD=12.5	4000																		
低温特性 Low Temperature Stability (インピーダンス比) Impedance Ratio(MAX)	<table border="1"> <tr> <td>定格電圧(Vdc) Rated Voltage</td> <td>10</td> <td>16</td> <td>25</td> <td>35</td> <td>(120Hz)</td> </tr> <tr> <td>Z(-25°C)/Z(20°C)</td> <td>3</td> <td>2</td> <td>2</td> <td>2</td> <td></td> </tr> <tr> <td>Z(-40°C)/Z(20°C)</td> <td>6</td> <td>4</td> <td>3</td> <td>3</td> <td></td> </tr> </table>	定格電圧(Vdc) Rated Voltage	10	16	25	35	(120Hz)	Z(-25°C)/Z(20°C)	3	2	2	2		Z(-40°C)/Z(20°C)	6	4	3	3			
定格電圧(Vdc) Rated Voltage	10	16	25	35	(120Hz)																
Z(-25°C)/Z(20°C)	3	2	2	2																	
Z(-40°C)/Z(20°C)	6	4	3	3																	

◆リプル電流補正係数 / MULTIPLIER FOR RIPPLE CURRENT

周波数(Hz) Frequency	120	1k	10k	100k≤
22~33µF	0.20	0.50	0.80	1.00
39~100µF	0.25	0.60	0.90	1.00
120~270µF	0.35	0.70	0.92	1.00
330~680µF	0.45	0.75	0.95	1.00
820~1800µF	0.50	0.80	0.96	1.00
2200µF	0.55	0.85	0.98	1.00

◆寸法図 / DIMENSIONS (mm)

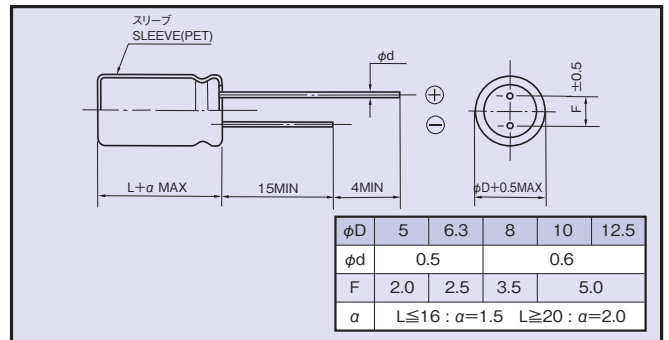

◆呼称方法 / PART NUMBER

□□□	ZT	□□□□□	M	□□□	□□	DXL
定格電圧 Rated Voltage	シリーズ名 Series	静電容量 Capacitance	静電容量許容差 Capacitance Tolerance	副記号 Option	リード加工記号 Lead Forming	ケースサイズ Case Size

◆副記号 / OPTION

	記号 Code
PETスリーブ PET Sleeve	なし Blank

◆標準品一覧表 / STANDARD SIZE

定格電圧 Rated Voltage (Vdc)	静電容量 Capacitance (μ F)	外形寸法 Size ϕ D×L(mm)	定格リップル電流 Rated ripple current (mA r.m.s./125°C, 100kHz)	インピーダンス(Ω MAX) Impedance	
				20°C, 100kHz	-10°C, 100kHz
10	56	5×11	250	0.40	1.3
	120	6.3×11	405	0.17	0.53
	330	8×11.5	760	0.094	0.29
	470	8×16	995	0.073	0.23
	470	10×12.5	1030	0.069	0.21
	680	8×20	1250	0.054	0.17
	680	10×16	1430	0.050	0.16
	1000	10×20	1500	0.030	0.090
	1200	10×23	1620	0.029	0.086
	1500	12.5×20	1720	0.028	0.069
2200	12.5×25	1900	0.024	0.059	
16	47	5×11	250	0.40	1.3
	100	6.3×11	405	0.17	0.53
	220	8×11.5	760	0.094	0.29
	330	8×16	995	0.073	0.23
	330	10×12.5	1030	0.069	0.21
	470	8×20	1250	0.054	0.17
	470	10×16	1430	0.050	0.16
	680	10×20	1500	0.030	0.090
	820	10×23	1620	0.029	0.086
	1000	12.5×20	1720	0.028	0.069
1500	12.5×25	1900	0.024	0.059	
25	33	5×11	250	0.40	1.3
	56	6.3×11	405	0.17	0.53
	150	8×11.5	760	0.094	0.29
	220	8×16	995	0.073	0.23
	220	10×12.5	1030	0.069	0.21
	270	8×20	1250	0.054	0.17
	330	10×16	1430	0.050	0.16
	470	10×20	1500	0.030	0.090
	560	10×23	1620	0.029	0.086
	680	12.5×20	1720	0.028	0.069
	1000	12.5×25	1900	0.024	0.059
35	22	5×11	250	0.40	1.3
	56	6.3×11	405	0.17	0.53
	100	8×11.5	760	0.094	0.29
	120	8×16	995	0.073	0.23
	150	10×12.5	1030	0.069	0.21
	180	8×20	1250	0.054	0.17
	220	10×16	1430	0.050	0.16
	270	10×20	1500	0.030	0.090
	330	10×23	1620	0.029	0.086
	470	12.5×20	1720	0.028	0.069
	560	12.5×25	1900	0.024	0.059