

1.5MHz Low-Voltage Rail-to-Rail Output Operational Amplifier (compatible to LMV358)

Feature

- Stable 1.5MHz GBWP with Low I_Q of Only 330 μ A Typical per Amplifier
- Offset Voltage: +/-900uV Maximum
- High Slew Rate: 3.7V/ μ s
- Input Bias Current: 1pA Typical
- CMRR/PSRR:100dB/100dB
- Settling time to 0.1% with 2V Step: 0.46us
- Beyond the Rails Input Common-Mode Range
- Output Swing to within 10mV Typical of each Rail
- No Phase Reversal for Overdriven Inputs
- Supply Voltage Range: 2.5V to 5.5V
- -40 $^{\circ}$ C to 125 $^{\circ}$ C Operation Range
- Green, Popular Type Package

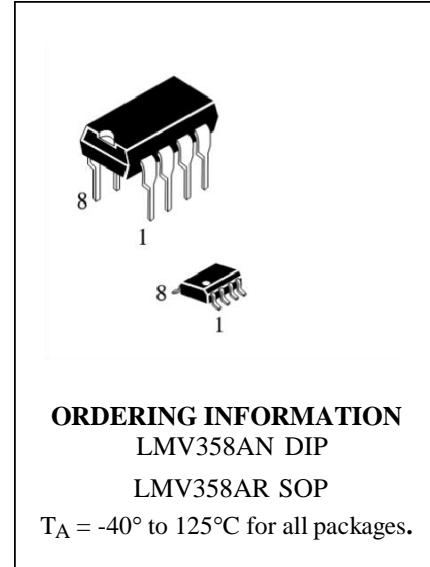

Applications

- Active Filters, ASIC Input or Output Amplifier
- Sensor Interface
- Smoke/Gas/Environment Sensors
- Portable Instruments and Mobile Device
- Audio Output
- PCMCIA Cards
- Battery or Solar Power Systems
- Medical Equipment
- Piezo Electrical Transducer Amplifier

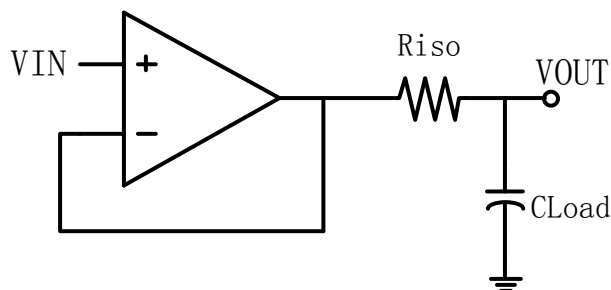

Absolute Maximum Ratings

(If out of these ratings, the filter may be fail or damaged)

Table 1

Symbol	parameter	rating	units
VDD	Power supply	6	V
T _A	Operating ambient Temperature Range	-40~+125	°C
T _{STG}	Storage Temperature	-65~+150	°C

Recommended Operating Conditions

Table 2

Symbol	parameter	rating	units
VDD	Power supply	2.5~5.5	V
T _A	Operating ambient Temperature Range	-40~+125	°C

Electrical Characteristics

 Specifications are at $T_A=+27^{\circ}\text{C}$, $V_{DD}=5\text{V}$, $V_{CM}=V_{OUT}=V_{DD}/2$, $R_L=10\text{Kohm}$, $C_L=100\text{pF}$

Symbol	Parameter	Spec			Units
		Min	Typ	Max	
VCC	Operating Supply Voltage	2.5	5	5.5	V
V _{OS}	Input Offset Voltage	-900	+/-500	+900	uV
V _{OS_TC}	Input Offset voltage Temp Drift		4		μV/°C
e _n	Input Voltage Noise Density: f=1KHz		25		nV/√Hz
C _{IN}	Input Capacitance	Differential	1.5		pF
		Common Mode	3.0		
R _{IN}	Input Resistance	>100			GΩ
I _Q	Quiescent Current per Amplifier		150	330	uA
I _{out}	Output Current		50		mA
V _{in_cm}	Common mode Input voltage	0		VDD-0.1	V
V _{OL}	Output Voltage from supply Swing		10		mV
CMRR	Common Mode Rejection Ratio		100		dB
I _{sc}	Output short-circuit current		80		mA
PM	Phase Margin		65		°
GM	Gain Margin		-10		dB
GBWP	Gain-Bandwidth Product		1.5		MHz
PSRR	Power supply rejection ratio: 1Hz 1KHz		100		dB
			72		
ts	Settling time, 1.5V to 3.5V, Unity Gain: 0.1%		0.46		μs
SR	Slew Rate		3.7		μs
THD+Noise	Total Harmonic Distortion and Noise: f=1KHz		0.0007		%

Typical performance characteristics

At $T_A=+27^\circ\text{C}$, $V_{dd}=5\text{V}$, $V_{CM}=V_{OUT}=V_{DD}/2$, $R_L=10\text{Kohm}$, $C_L=100\text{pF}$

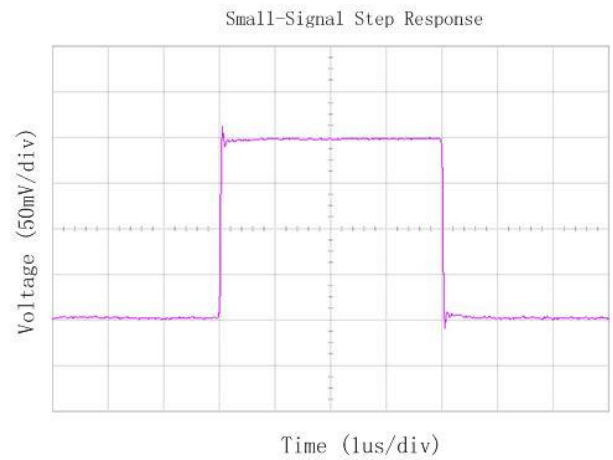
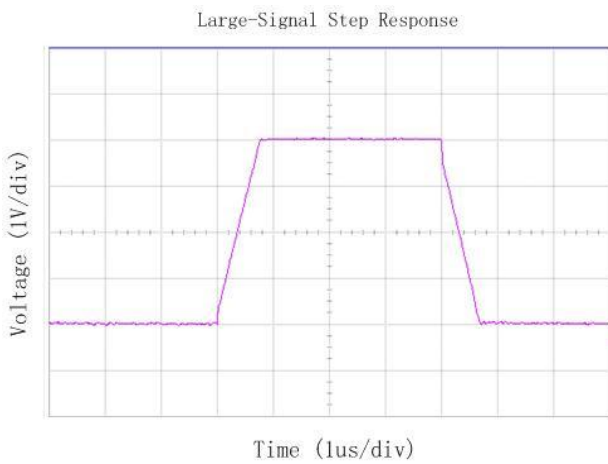
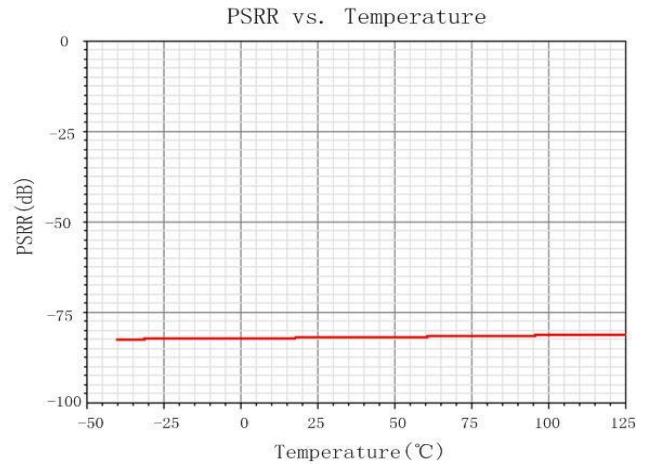
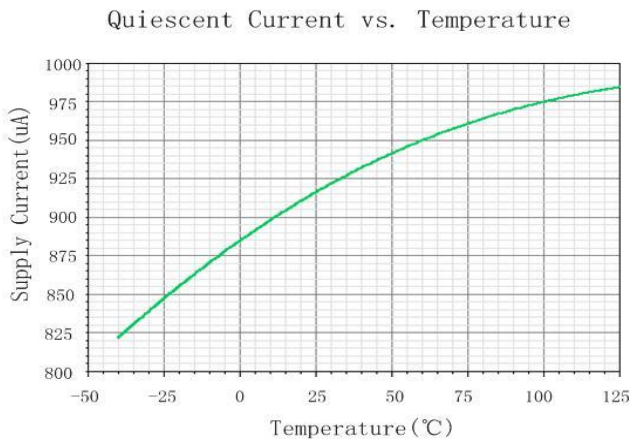
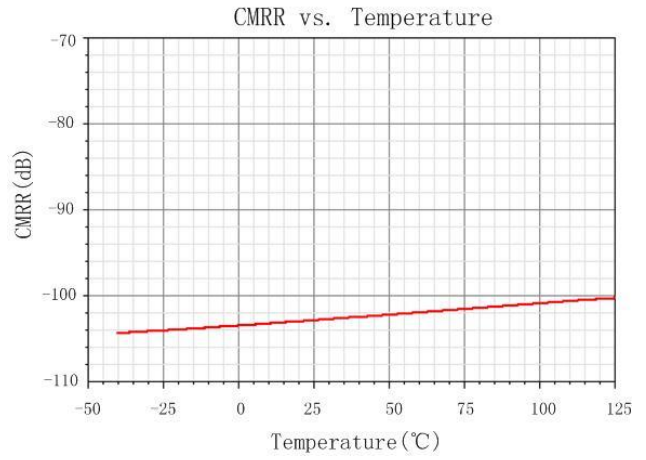
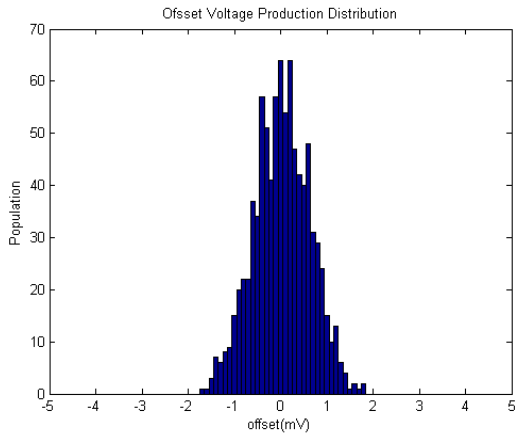

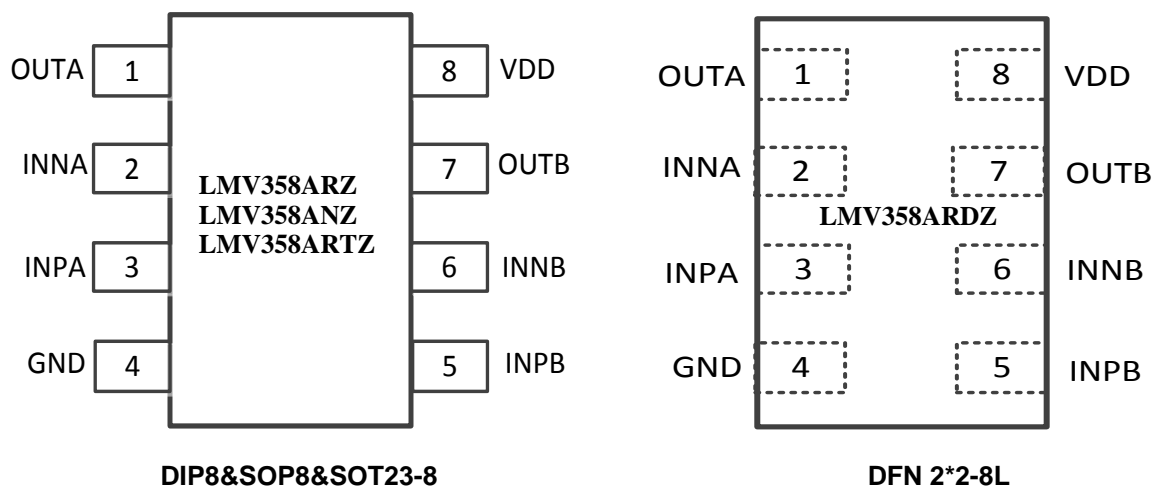
Pin Configuration and Function

Name	I/O	Analog/Digital	Description
INP	I	A	Non-Inverting Input of Amplifier. Voltage range of this pin can go from 0 to VDD.
GND	GROUND	GROUND	Ground pin. Connect to the most negative supply, ALL GND pads are connected on die.
INN	I	A	Inverting Input of Amplifier. This pin has same voltage range as INP.
OUT	O	A	Amplifier Output. The voltage range extends to within millivolts of each supply rail.
VDD	POWER	POWER	Power supply (5V) ,connect to positive voltage supply

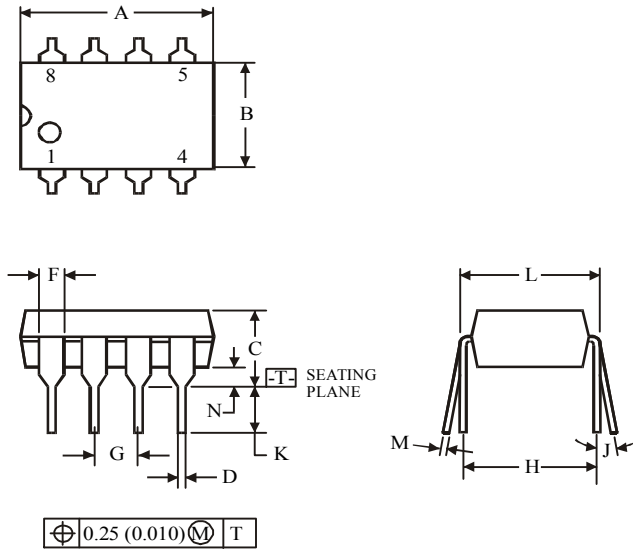
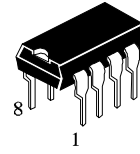
(DIP8)

Symbol	Dimension, mm	
	MIN	MAX
A	8.51	10.16
B	6.1	7.11
C		5.33
D	0.36	0.56
F	1.14	1.78
G	2.54	
H	7.62	
J	0°	10°
K	2.92	3.81
L	7.62	8.26
M	0.2	0.36
N	0.38	

NOTES:

- Dimensions "A", "B" do not include mold flash or protrusions.
Maximum mold flash or protrusions 0.25 mm (0.010) per side.

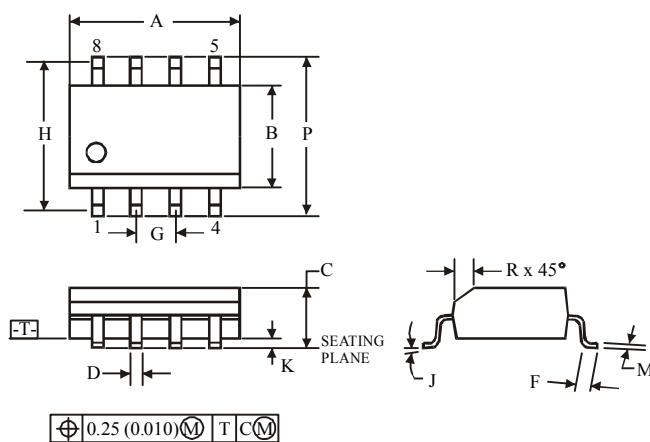
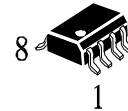
(SOP8)

Symbol	Dimension, mm	
	MIN	MAX
A	4.8	5
B	3.8	4
C	1.35	1.75
D	0.33	0.51
F	0.4	1.27
G	1.27	
H	5.72	
J	0°	8°
K	0.1	0.25
M	0.19	0.25
P	5.8	6.2
R	0.25	0.5

NOTES:

- Dimensions A and B do not include mold flash or protrusion.
- Maximum mold flash or protrusion 0.15 mm (0.006) per side for A; for B - 0.25 mm (0.010) per side.