

Single Supply Quad Operational Amplifiers

The HT3403 is a low cost, quad operational amplifier with true differential inputs. The device has electrical characteristics similar to the popular MC1741C. However, the HT3403 has several distinct advantages over standard operational amplifier types in single supply applications. The quad amplifier can operate at supply voltages as low as 3.0 V or as high as 36 V with quiescent currents about one third of those associated with the MC1741C (on a per amplifier basis). The common mode input range includes the negative supply, thereby eliminating the necessity for external biasing components in many applications. The output voltage range also includes the negative power supply voltage.

Features

- Short Circuit Protected Outputs
- Class AB Output Stage for Minimal Crossover Distortion
- True Differential Input Stage
- Single Supply Operation: 3.0 V to 36 V
- Split Supply Operation: ± 1.5 V to ± 18 V
- Low Input Bias Currents: 500 nA Max
- Four Amplifiers Per Package
- Internally Compensated
- Similar Performance to Popular MC1741C
- Industry Standard Pin-outs
- ESD Diodes Added for Increased Ruggedness
- Pb-Free Packages are Available

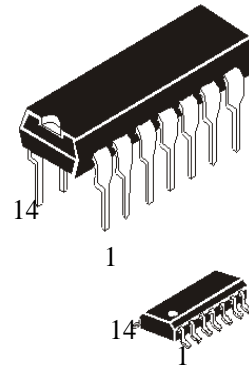

ORDERING INFORMATION

HT3303ANZ DIP

HT3303ARZ SOP

$T_A = -40^\circ$ to 85°C for all packages.

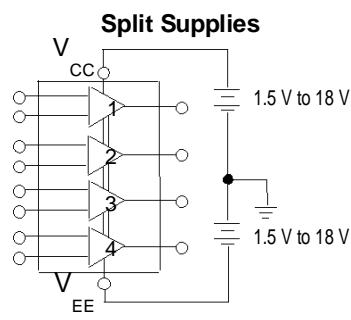
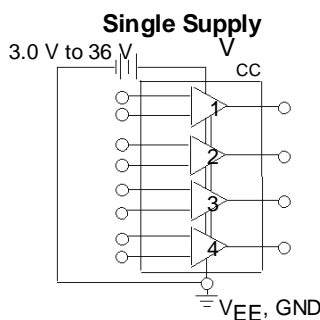

PIN CONNECTIONS

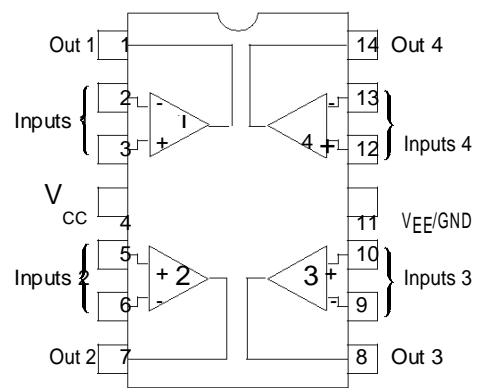

(Top View)

MAXIMUM RATINGS

Rating	Symbol	Value	Unit
Power Supply Voltages Single Supply	V_{CC}	36	Vdc
Split Supplies	V_{CC}, V_{EE}	± 18	
Input Differential Voltage Range (Note 1)	V_{IDR}	± 36	Vdc
Input Common Mode Voltage Range (Notes 1 and 2)	V_{ICR}	± 18	Vdc
Storage Temperature Range	T_{stg}	-55 to +125	°C
Operating Ambient Temperature Range	T_A	HT3303 -40 to +85 HT3403 0 to +70	°C
Junction Temperature	T_J	150	°C

Stresses exceeding Maximum Ratings may damage the device. Maximum Ratings are stress ratings only. Functional operation above the Recommended Operating Conditions is not implied. Extended exposure to stresses above the Recommended Operating Conditions may affect device reliability.

1. Split power supplies.
2. For supply voltages less than ± 18 V, the absolute maximum input voltage is equal to the supply voltage.

ELECTRICAL CHARACTERISTICS

 (V_{CC} = +15 V, V_{EE} = -15 V for HT3403; V_{CC} = +14 V, V_{EE} = GND for HT3303 T_A = 25°C, unless otherwise noted.)

Characteristic	Symbol	HT3403			HT3303			Unit
		Min	Typ	Max	Min	Typ	Max	
Input Offset Voltage T _A = T _{high} to T _{low} (Note 3)	V _{IO}	-	2.0	10	-	2.0	8.0	mV
Input Offset Current I _{IO} = I _{IO} high - I _{IO} low	I _{IO}	-	30	50	-	30	75	nA
Large Signal Open Loop Voltage Gain V _O = ±10 V, R _L = 2.0 kW A high low	A _{VOL}	20	200	-	20	200	-	V/mV
Input Bias Current I _{IB} = I _{IB} high - I _{IB} low	I _{IB}	-	-200	-500	-	-200	-500	nA
Output Impedance f = 20 Hz	Z _O	-	75	-	-	75	-	Ω
Input Impedance f = 20 Hz	Z _i	0.3	1.0	-	0.3	1.0	-	MΩ
Output Voltage Range R _L = 10 kW R _L = 2.0 kW R _L = 2.0 kW, T _A = T _{high} to T _{low}	V _O	±12 ±10 ±10	±13.5 ±13 -	- - -	12 10 10	12.5 12 -	- - -	V
Input Common Mode Voltage Range	V _{ICR}	+13 V -V _{EE}	+13 V -V _{EE}	-	+12 V -V _{EE}	+12.5 V -V _{EE}	-	V
Common Mode Rejection R _S ≤ 10 kW	CMR	70	90	-	70	90	-	dB
Power Supply Current (V _O = 0) R _L = ∞	I _{CC} I _{EE}	-	2.8	7.0	-	2.8	7.0	mA
Individual Output Short-Circuit Current (Note 4)	I _{SC}	±10	±20	±45	±10	±30	±45	mA
Positive Power Supply Rejection Ratio	PSRR+	-	30	150	-	30	150	mV/V
Negative Power Supply Rejection Ratio	PSRR-	-	30	150	-	30	150	mV/V
Average Temperature Coefficient of Input Offset Current I _{IO} = I _{IO} high - I _{IO} low	DI _{IO} /DT	-	50	-	-	50	-	pA/°C
Average Temperature Coefficient of Input Offset Voltage I _{IO} = I _{IO} high - I _{IO} low	DV _{IO} /DT	-	10	-	-	10	-	mV/°C
Power Bandwidth A _V = 1, R _L = 10 kW, V _O = 20 V(p-p), THD = 5%	BW _p	-	9.0	-	-	9.0	-	kHz
Small-Signal Bandwidth A _V = 1, R _L = 10 kW, V _O = 50 mV	BW	-	1.0	-	-	1.0	-	MHz
Slew Rate A _V = 1, V _i = -10 V to +10 V	SR	-	0.6	-	-	0.6	-	V/ms
Rise Time A _V = 1, R _L = 10 kW, V _O = 50 mV	t _{RLH}	-	0.35	-	-	0.35	-	ms
Fall Time A _V = 1, R _L = 10 kW, V _O = 50 mV	t _{FLH}	-	0.35	-	-	0.35	-	ms
Overshoot A _V = 1, R _L = 10 kW, V _O = 50 mV	os	-	20	-	-	20	-	%
Phase Margin A _V = 1, R _L = 2.0 kW, V _O = 200 pF	fm	-	60	-	-	60	-	°
Crossover Distortion (V _{in} = 30 mV _{pp} , V _{out} = 2.0 V _{pp} , f = 10 kHz)	-	-	1.0	-	-	1.0	-	%

 3. HT3303: T_{low} = -40°C, T_{high} = +85°C, HT3403: T_{low} = 0°C, T_{high} = +70°C

4. Not to exceed maximum package power dissipation.

ELECTRICAL CHARACTERISTICS ($V_{CC} = 5.0\text{ V}$, $V_{EE} = \text{GND}$, $T_A = 25^\circ\text{C}$, unless otherwise noted.)

Characteristic	Symbol	HT3403			HT3303			Unit
		Min	Typ	Max	Min	Typ	Max	
Input Offset Voltage	V_{IO}	-	2.0	10	-	-	10	mV
Input Offset Current	I_{IO}	-	30	50	-	-	75	nA
Input Bias Current	I_{IB}	-	-200	-500	-	-	-500	nA
Large Signal Open Loop Voltage Gain $R_L = 2.0\text{ kW}$	A_{VOL}	10	200	-	10	200	-	V/mV
Power Supply Rejection Ratio	PSRR	-	-	150	-	-	150	mV/V
Output Voltage Range (Note 5) $R_L = 10\text{ kW}$, $V_{CC} = 5.0\text{ V}$ $R_L = 10\text{ kW}$, $5.0 \leq V_{CC} \leq 30\text{ V}$	V_{OR}	3.3 $V_{CC}-2.0$	3.5 $V_{CC}-1.7$	-	3.3 $V_{CC}-2.0$	3.5 $V_{CC}-1.7$	-	V_{pp}
Power Supply Current	I_{CC}	-	2.5	7.0	-	2.5	7.0	mA
Channel Separation $f = 1.0\text{ kHz to } 20\text{ kHz}$ (Input Referenced)	CS	-	-120	-	-	-120	-	dB

5. Output will swing to ground with a 10 kW pull down resistor.

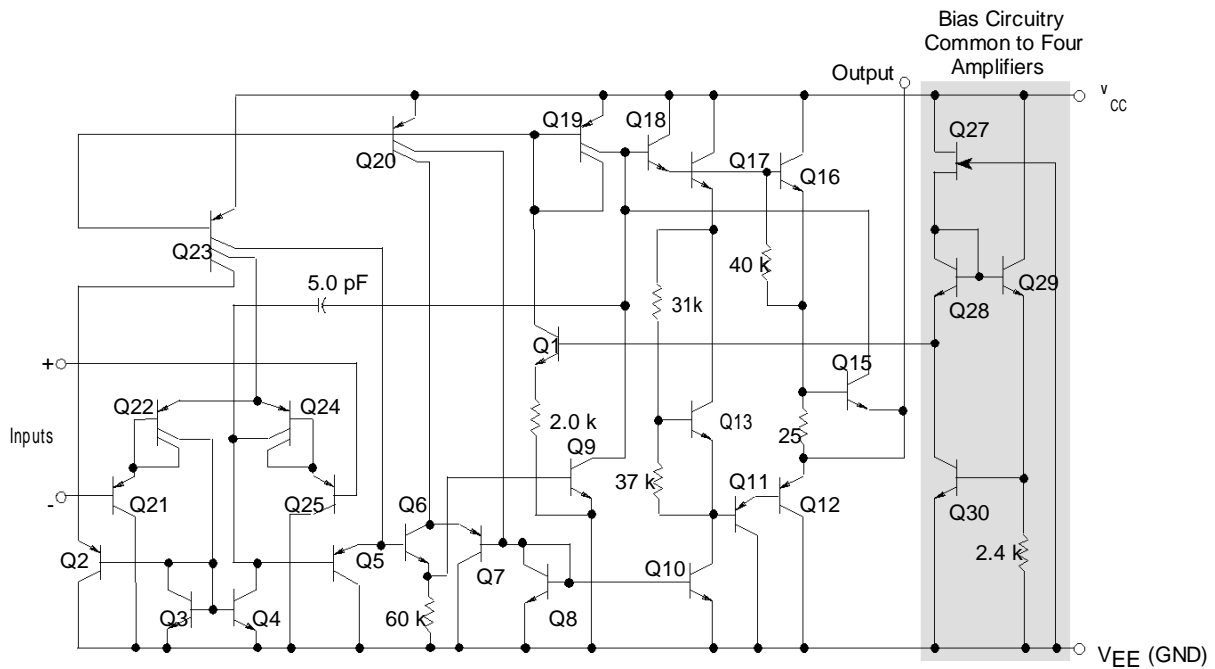
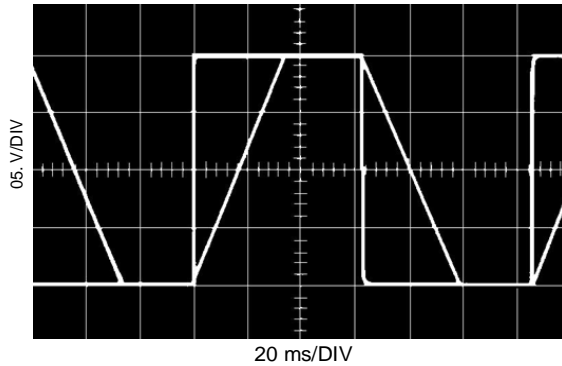

Figure 1. Representative Schematic Diagram
(1/4 of Circuit Shown)

CIRCUIT DESCRIPTION

Figure 2. Inverter Pulse Response

The HT3403/3303 is made using four internally compensated, two-stage operational amplifiers. The first stage of each consists of differential input device Q24 and Q22 with input buffer transistors Q25 and Q21 and the differential to single ended converter Q3 and Q4. The first

stage performs not only the first stage gain function but also performs the level shifting and Transconductance reduction functions. By reducing the Transconductance, a smaller compensation capacitor (only 5.0 pF) can be employed, thus saving chip area. The Transconductance reduction is accomplished by splitting the collectors of Q24 and Q22. Another feature of this input stage is that the input common mode range can include the negative supply or ground, in single supply operation, without saturating either the input devices or the differential to single-ended converter. The second stage consists of a standard current source load amplifier stage.

The output stage is unique because it allows the output to swing to ground in single supply operation and yet does not exhibit any crossover distortion in split supply operation. This is possible because Class AB operation is utilized.

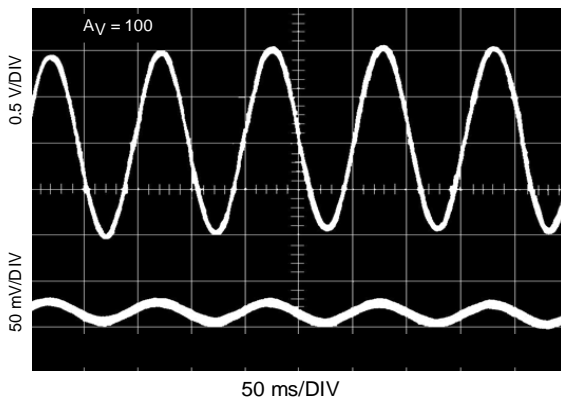
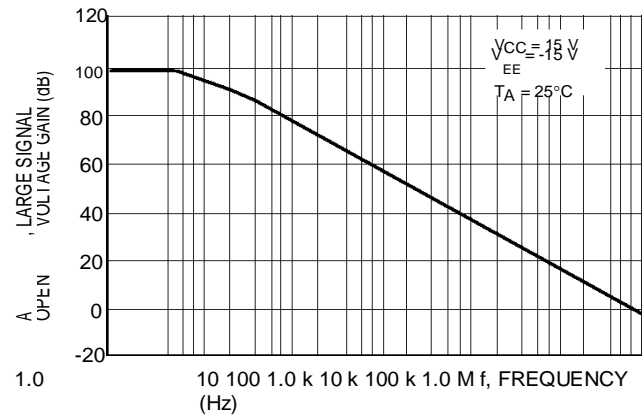
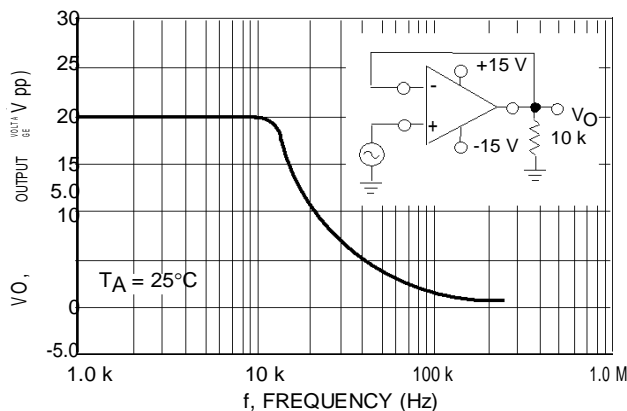
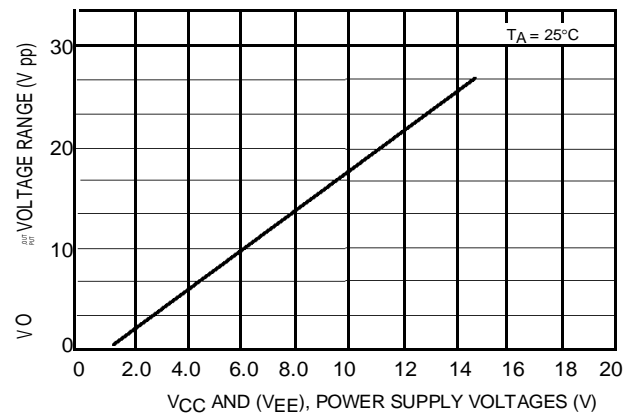
Each amplifier is biased from an internal voltage regulator which has a low temperature coefficient, thus giving each amplifier good temperature characteristics as well as excellent power supply rejection.

Figure 3. Sine Wave Response

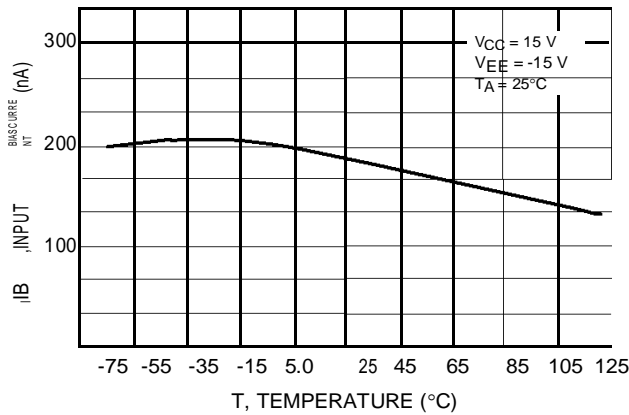
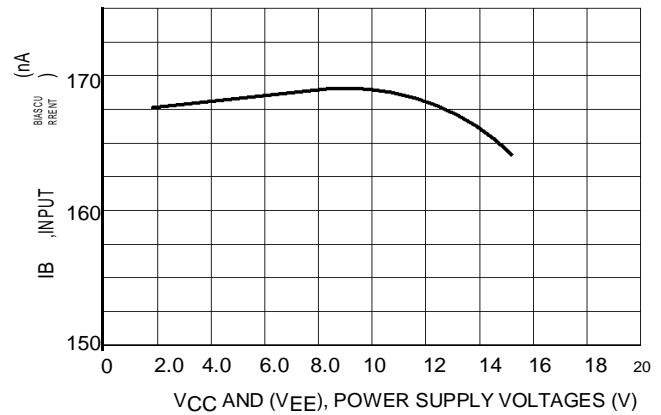
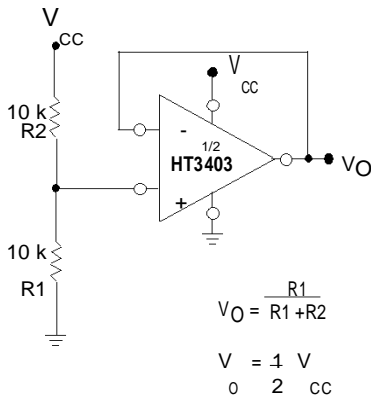
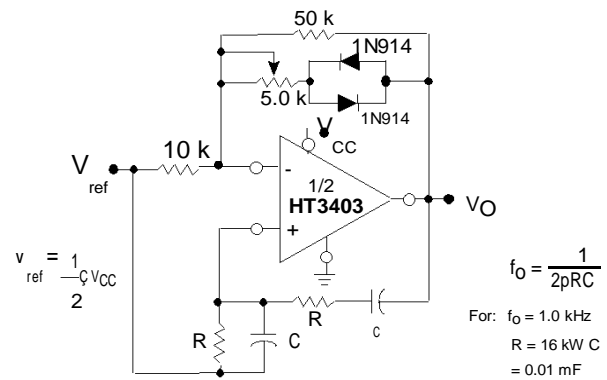
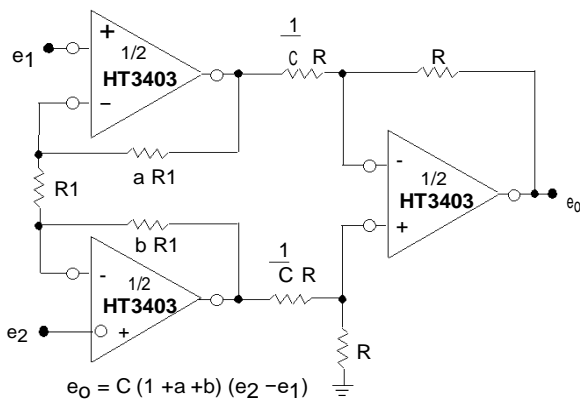
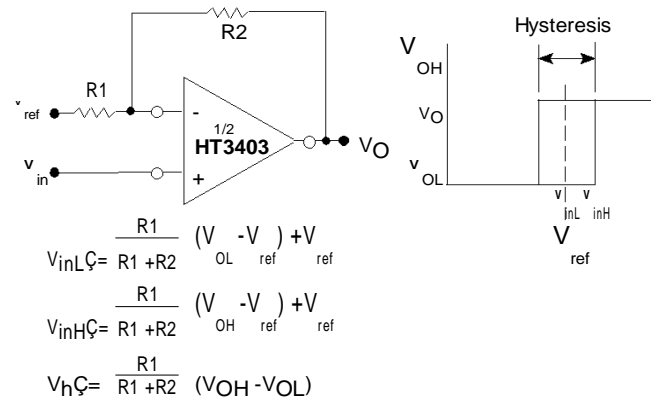
Figure 4. Open Loop Frequency Response

Figure 5. Power Bandwidth

Figure 6. Output Swing versus Supply Voltage

Figure 7. Input Bias Current versus Temperature

Figure 8. Input Bias Current versus Supply Voltage

Figure 9. Voltage Reference

Figure 10. Wien Bridge Oscillator

Figure 11. High Impedance Differential Amplifier

Figure 12. Comparator with Hysteresis

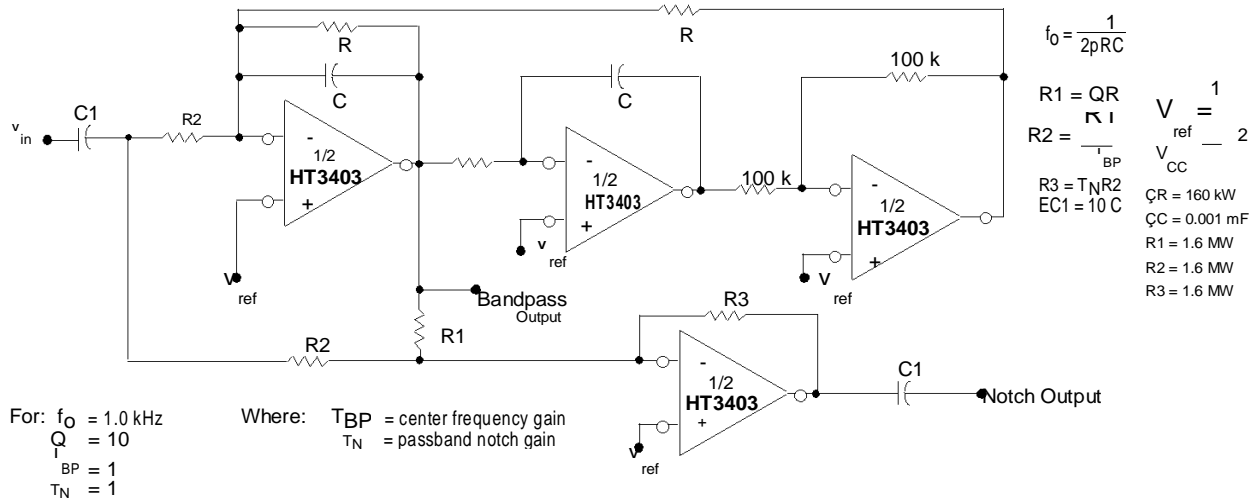

Figure 13. Bi-Quad Filter

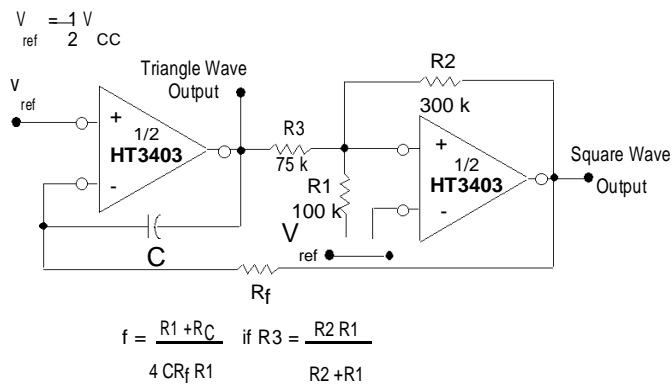
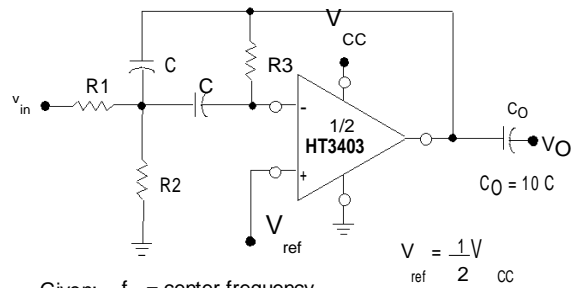

Figure 14. Function Generator



Given: f_0 = center frequency

$A(f_0)$ = gain at center frequency

Choose value f_0, C

$$\text{Then: } R3 = \frac{Q}{\omega_0 C} \quad R1 = \frac{R3}{2 A(f_0)} \quad R2 = \frac{R1 R5}{4Q^2 R1 - R5}$$

For less than 10% error from operational amplifier $\frac{\omega_0}{BW} < 0.1$

where f_0 and BW are expressed in Hz.

If source impedance varies, filter may be preceded with voltage follower buffer to stabilize filter parameters.

Figure 15. Multiple Feedback Bandpass Filter

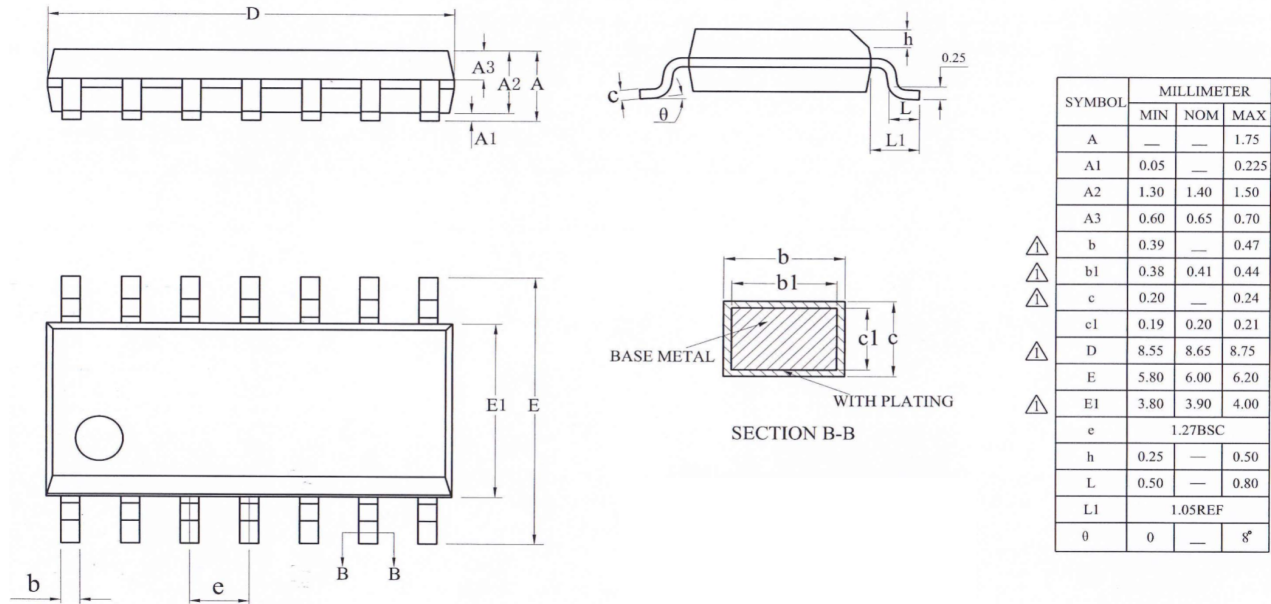
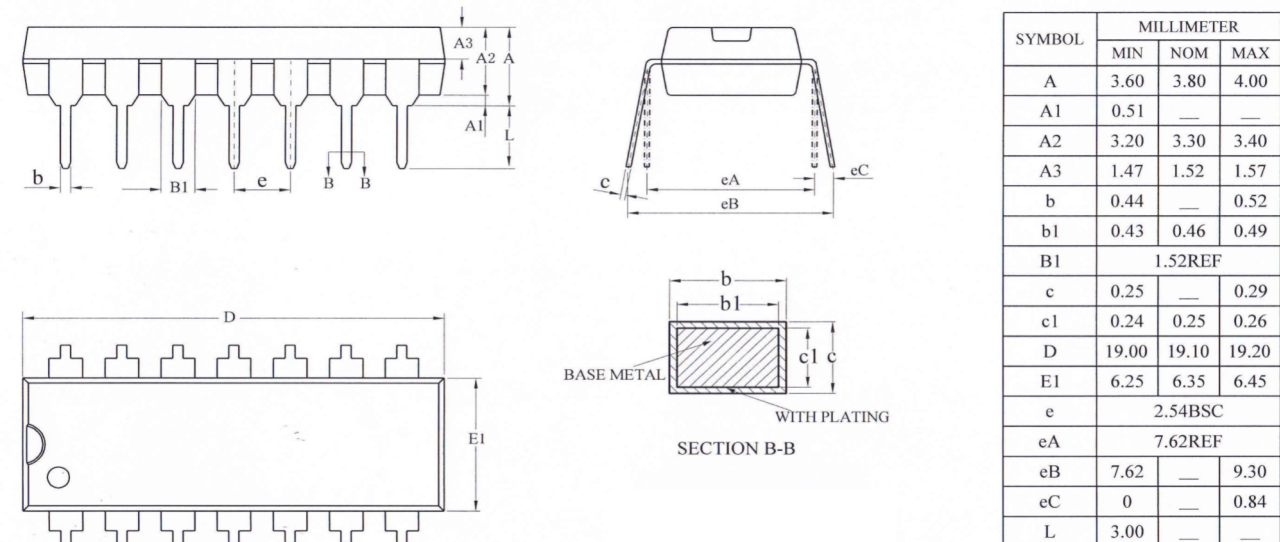
SOP14

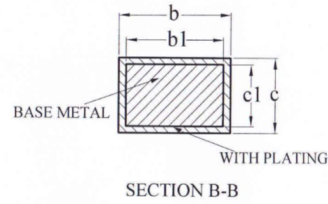
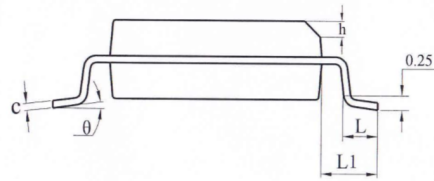
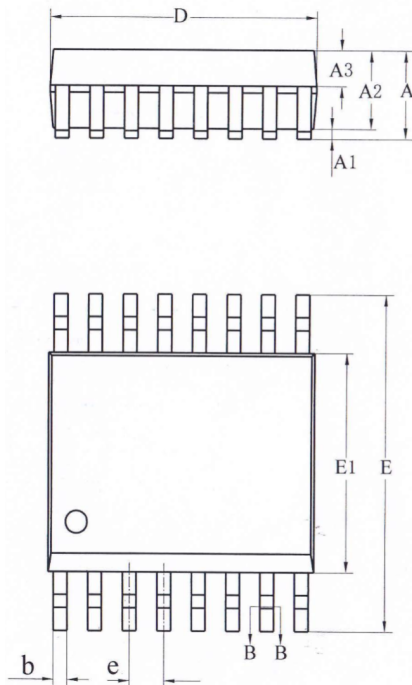
DIP14

SSOP14

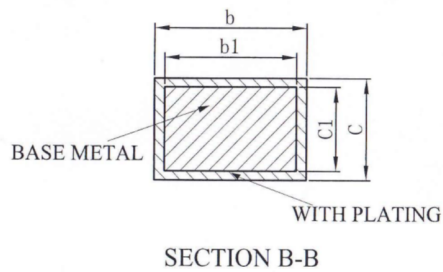
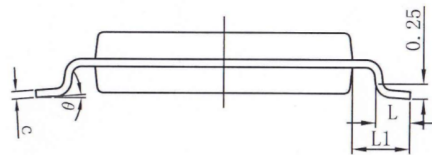
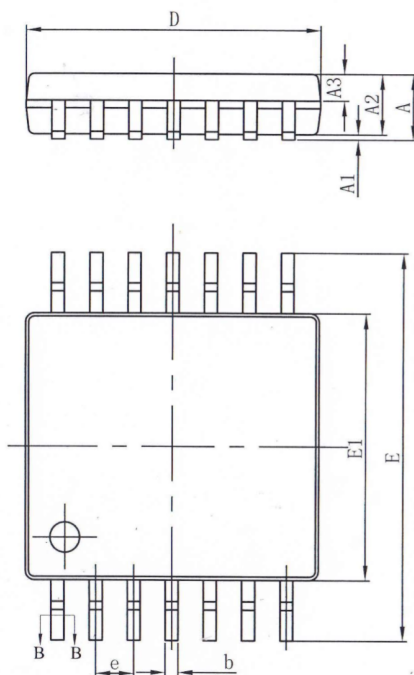
SYMBOL	MILLIMETER		
	MIN	NOM	MAX
A	—	—	1.75
A1	0.10	—	0.225
A2	1.30	1.40	1.50
A3	0.55	0.60	0.65
b	0.23	—	0.31
b1	0.22	0.25	0.28
c	0.20	—	0.24
c1	0.19	0.20	0.21
D	4.80	4.90	5.00
E	5.80	6.00	6.20
E1	3.80	3.90	4.00
e	0.635BSC		
h	0.25	—	0.50
L	0.50	0.65	0.80
L1	1.05REF		
θ	0	—	8°

TSSOP14

SYMBOL	MILLIMETER		
	MIN	NOM	MAX
A	—	—	1.20
A1	0.05	—	0.15
A2	0.90	1.00	1.05
A3	0.39	0.44	0.49
b	0.20	—	0.28
b1	0.19	0.22	0.25
c	0.13	—	0.17
c1	0.12	0.13	0.14
D	4.90	5.00	5.10
E1	4.30	4.40	4.50
E	6.20	6.40	6.60
e	0.65BSC		
L	0.45	0.60	0.75
L1	1.00BSC		
θ	0	—	8°