

MICROCIRCUIT INTERFACE TRANSCEIVER OF THE SERIAL DATA OF THE STANDARD RS -232

Microcircuits HT3232 is interface transceiver of serial data under RS - 232 standard with single power supply source & bipolar output voltage of transmitter, forming by build-in voltage multiplier on 4 external capacities, 0.1 μF. HT3232 correspond to EIA/TIA-232E, V.28 standard and is purposed for application in modern high efficient calculating systems with the wide range of supply voltage, fast-operating electronic devices with high level of fidelity of information exchange among distant devices.

Functions and structure:

- Microcircuit contains 2 transmitters and 2 receivers of the serial data of the standard RS-232.
- The microcircuit supply voltage range is from 3.0 to 5.5 V.
- Enhanced ESD Specifications:
 - 15kV IEC61000-4-2 Air Discharge
 - 8kV IEC61000-4-2 Contact Discharge

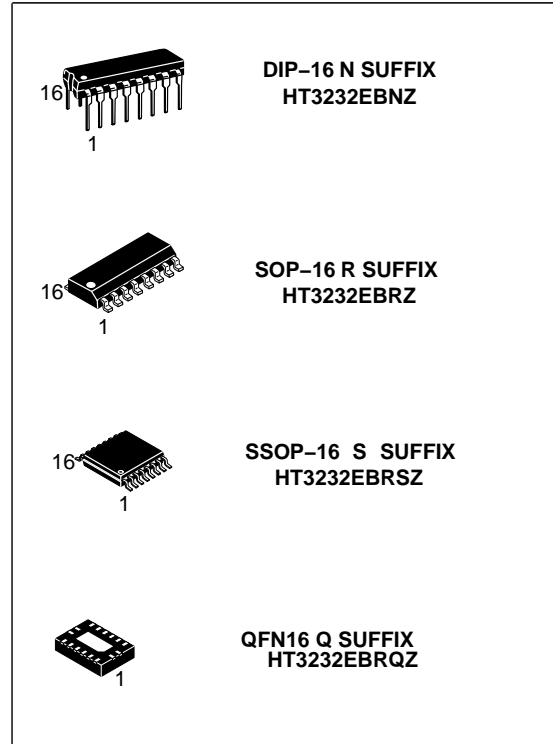

Truth Table

Input	Output
RXIN, TXIN	$\overline{\text{RXOUT}}, \overline{\text{TXOUT}}$
H	L
L	H
Note – L – low voltage level; H – high voltage level	

Pinning

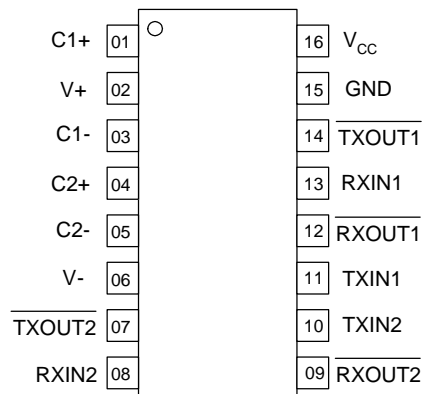

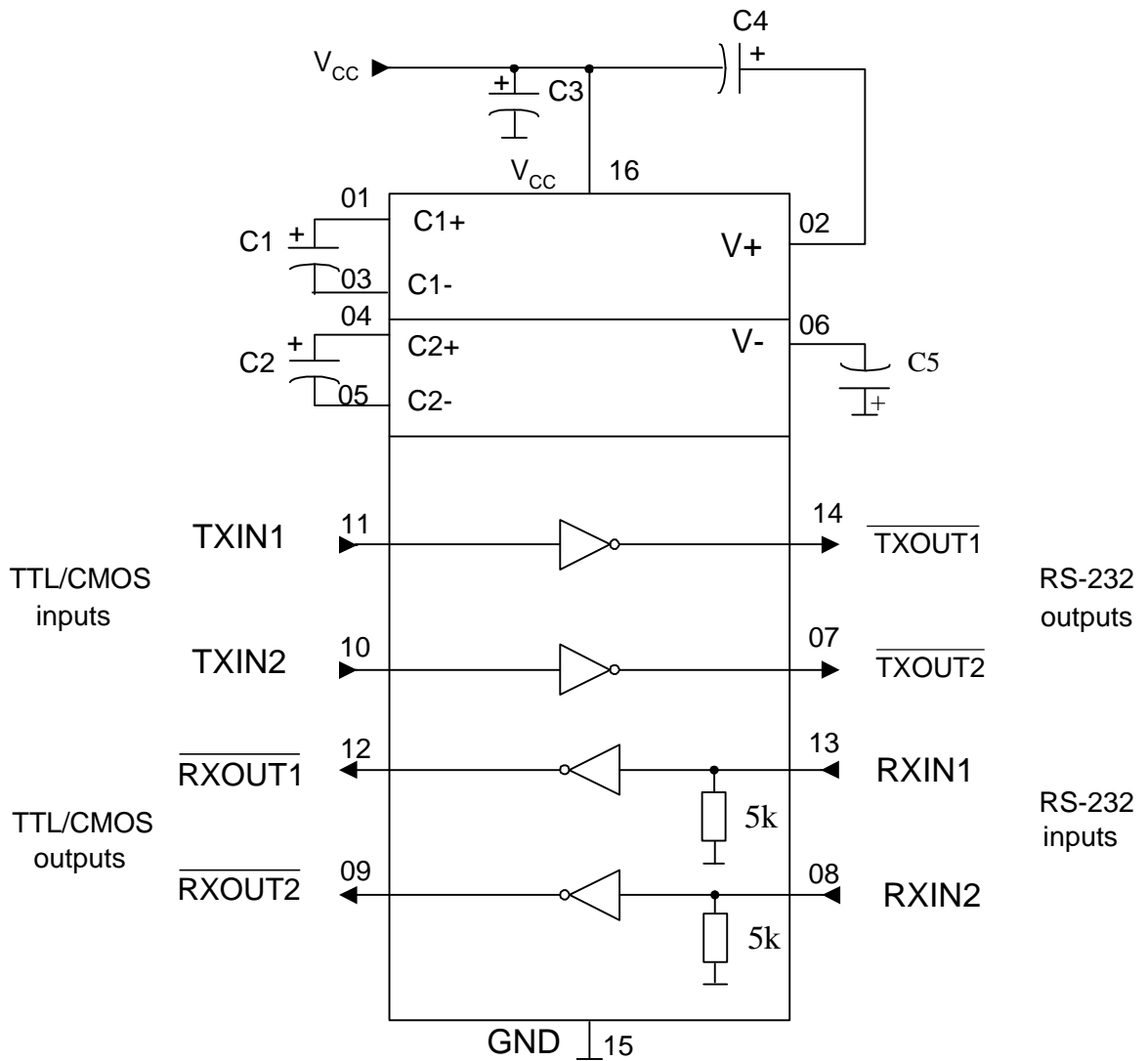
Functional diagram

C1 – capacitor 0.1 $\mu\text{F} \pm 10\%$ for $U_{\text{CC}} = 3.3 \text{ V} \pm 10\%$ (0.047 $\mu\text{F} \pm 10\%$ for $U_{\text{CC}} = 5.0 \text{ V} \pm 10\%$)

C2, C4, C5– capacitors 0.1 $\mu\text{F} \pm 10\%$ for $U_{\text{CC}} = 3.3 \text{ V} \pm 10\%$ (0.33 $\mu\text{F} \pm 10\%$ for $U_{\text{CC}} = 5.0 \text{ V} \pm 10\%$)

C3 – capacitor 0.1 $\mu\text{F} \pm 10\%$

Pin description table

Pin number	Pin description	Symbol
01	Positive terminal of the voltage multiplier charge-pump capacitor	C1+
02	Positive voltage multiplier output	V+
03	Negative terminal of the voltage multiplier charge-pump capacitor	C1-
04	Positive terminal of the voltage multiplier charge-pump capacitor	C2+
05	Negative terminal of the voltage multiplier charge-pump capacitor	C2-
06	Negative voltage multiplier output	V-
07	Transmitter output (RS-232 levels)	$\overline{\text{TXOUT2}}$
08	Receiver input (RS-232 levels)	RXIN2
09	Receiver output (TTL/CMOS levels)	$\overline{\text{RXOUT2}}$
10	Transmitter input (TTL/CMOS levels)	TXIN2
11	Transmitter input (TTL/CMOS levels)	TXIN1
12	Receiver output (TTL/CMOS levels)	$\overline{\text{RXOUT1}}$
13	Receiver input (RS-232 levels)	RXIN1
14	Transmitter output (RS-232 levels)	$\overline{\text{TXOUT1}}$
15	Common pin	GND
16	Supply voltage	V

Maximum Ratings & Recommended Operating Conditions

Parameter, unit	Symbol	Recommended operating conditions		Maximum rate	
		min	max	min	max
Supply voltage, V	U_{CC}	3.0	5.5	-0.3	6.0
Voltage applied to transmitter output, V	U	–	–	-13.2	13.2
Multiplier positive output voltage, V	U+	5.0	–	-0.3	7.0
Multiplier negative output voltage, V	U-	-5.0	–	-7.0	0.3
Receiver input voltage, V	U	-25	25	-25	25
Receiver output voltage, V	U	–	–	-0.3	$U_{CC}+0.3$
Transmitter low level input voltage, V	U	0	0.8	-0.3	–
Transmitter high level input voltage, V	U_{IH}	2.0 ($U_{CC}=3.3\text{ V}$)	U_{CC}	–	6
		2.4 ($U_{CC}=5.0\text{ V}$)			
Multiplier outputs voltages difference, V	$U_{+}+U_{-}$	–	–	–	13
Receiver low level threshold input voltage, V	U_{ITL}	0.6 ($U_{CC}=3.3\text{ V}$)	–	–	–
		0.8 ($U_{CC}=5.0\text{ V}$)			
Receiver high level threshold input voltage, V	U_{ITH}	–	2.4	–	–

Electric parameters

Parameter, unit	Symbol	Norm		Mode	T _A , °C
		Min	Max		
Supply current, μA	I _{CC1}	-	1.0	U _{CC} = 3.3 V; 5.0 V; U _{IL} = 0 V	25±10
			1.4		-40; 85
Receiver					
Low level output voltage, V	U _{OLR}	-	0.3	U _{CC} = 3.3V ±10%; U _{ITH} = 2.4V; I = 1.6 mA	25±10
			0.4		-40; 85
			0.3	U _{CC} = 5.0V ±10%; U _{ITH} = 2.4V; I = 1.6 mA	25±10
			0.4		-40; 85
High level output voltage, V	U _{OHR1}	2.5	-	U _{CC} = 3.3V ±10%; U _{ITL} = 0.6 V; I = -1.0 mA	25±10
		2.4			-40; 85
	U _{OHR2}	4.0		U _{CC} = 5.0V ±10%; U _{ITL} = 0.8 V; I = -1.0 mA	25±10
		3.9			-40; 85
Receiver hysteresis, V	U _h	0.2	1.0	U = 3.3 V ± 10%; 5.0 V ± 10%	25±10
Input resistance, kOhm	R	3	7	-	25±10
OFF-ON switching propagation delay, ns	t _{PHLR} , t	-	1500	U _{CC} = 5.0V ±10 %; C _L = 150 pF; U _{IL} = 0 V; U _{IH} = 3.0 V; t = t ≤ 10 ns	25±10
Propagation delays difference, ns	t _{SKD}	-	600		
Transmitter					
Low level output voltage, V	U _{OLT1}	-	-5.07	U _{CC} = 3.3V ±10%; U _{IH} = 2.0V; R = 3 kOhm	25±10
			-5.0		-40; 85
	U _{OLT2}		-5.07	U _{CC} = 5.0V ±10%; U _{IH} = 2.4V; R = 3 kOhm	25±10
			-5.0		-40; 85
High level output voltage, V	U _{OHT}	5.07	-	U _{CC} = 3.3V ±10%; U _{IL} = 0.8V; R = kOhm	25±10
		5.0			-40; 85
		5.07		U _{CC} = 5.0V ±10%; U _{IL} = 0.8V; R = kOhm	25±10
		5.0			-40; 85
Transmitter hysteresis, V	U _h	0.1	1.0	U = 3.3 V ± 10%; 5.0 V ± 10%	25±10
Low level input leakage current, μA	I _{ILL}	-	-0.5	U _{CC} = 5.5 V; U _{IL} = 0V	25±10
			-1.0		-40; 85
High level input leakage current, μA	I _{ILH}	-	0.5	U _{CC} = 5.5 V; U _{IH} = 5.5V	25±10
			1.0		-40; 85
Output resistance , Ohm	R _O	350	-	U _{CC} = U _{V+} * = U _{V-} * = 0 V; U = ±2 V	25±10
		300			-40; 85

Electric parameters

Parameter, unit	Symbol	Norm		Mode	T _A , °C
		Min	Max		
Transmitter					
Short circuit current, mA	I _{OS}	-	53	U _{CC} = 3.6 V	25±10
			60		-40; 85
			-53	U _{CC} = 3.6 V	25±10
			-60		-40; 85
			53	U _{CC} = 5.5 V	25±10
			60		-40; 85
			-53	U _{CC} = 5.5 V	25±10
			-60		-40; 85
Low level output current for OFF-state, µA	I _{OZLT}	-	-10	U _{CC} = 0V; U _O = -12 V; transmitter output is disabled	25±10
			-25		-40; 85
High level output current for OFF-state, µA	I _{OZHT}	-	10	U _{CC} = 0V; U _O = 12 V; transmitter output is disabled	25±10
			25		-40; 85
Maximum Data Rate, Kbit/s	ST	140	-	R _L = 3 kOhm; C _L = 1000 pF	25±10
		120			-40; 85
Transition-Region Slew Rate, V/µs	SR	6	30	U _{CC} = 3.3 V; R _L = (3-7) kOhm; U _{OT} is from +3 to -3 V or from -3 to +3 V; C _L = (150-1000) pF	25±10
		4	30		
Propagation delays difference, ns	t _{SKEW}	-	600	U _{CC} = 5.0V ±10 %; U _{IL} = 0 V; U _{IH} = 3.0 V; t _{LH} = t _{HL} ≤ 10 ns; R = 3 kOhm; C = 1000 pF	
* U _{V+} , U _{V-} - voltages applied to pins 02, 06. Note – Electric parameters is indicated for C1=0.047 µF, C2-C4 = 0.33 µF & U _{CC} = 5.0 V±10 % (or C1-C4 = 0.1 µF & U = 3.3 V±10 %)					

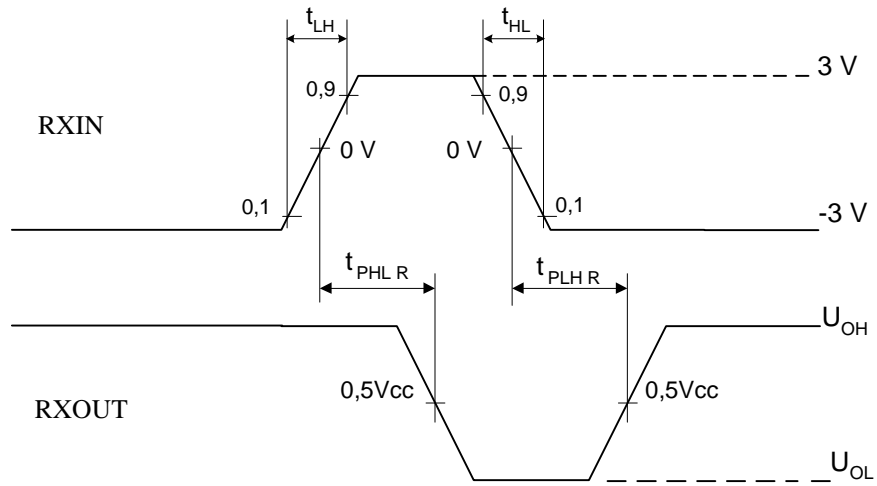

Receiver output & input signals time diagram

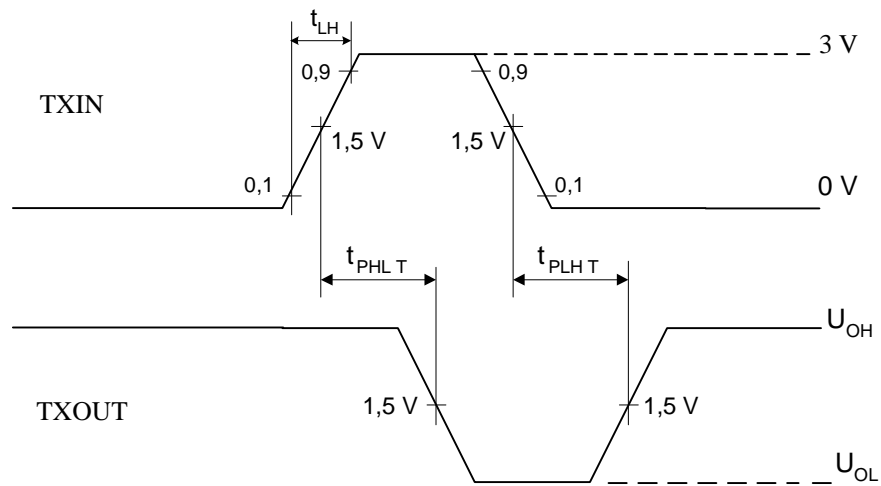

Transmitter output & input signals time diagram

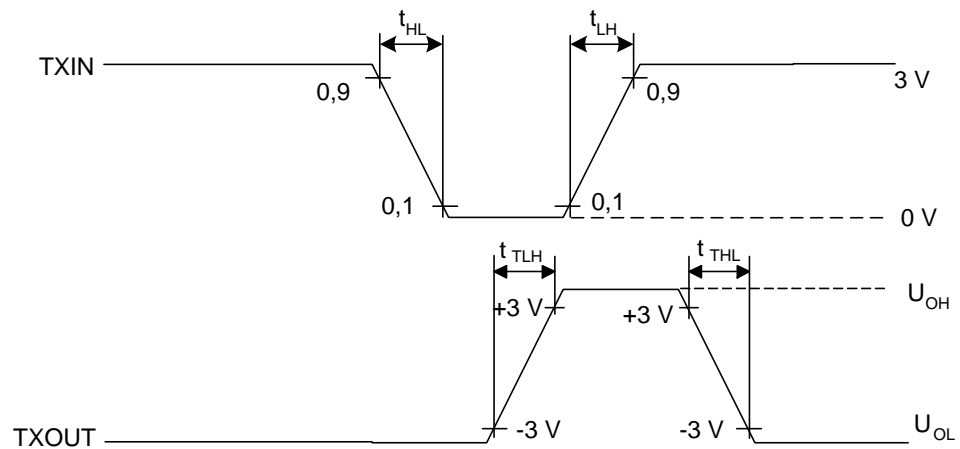

Transmitter output & input signals time diagram

Package Dimensions

DIP16-P-300-2.54A

Unit: mm

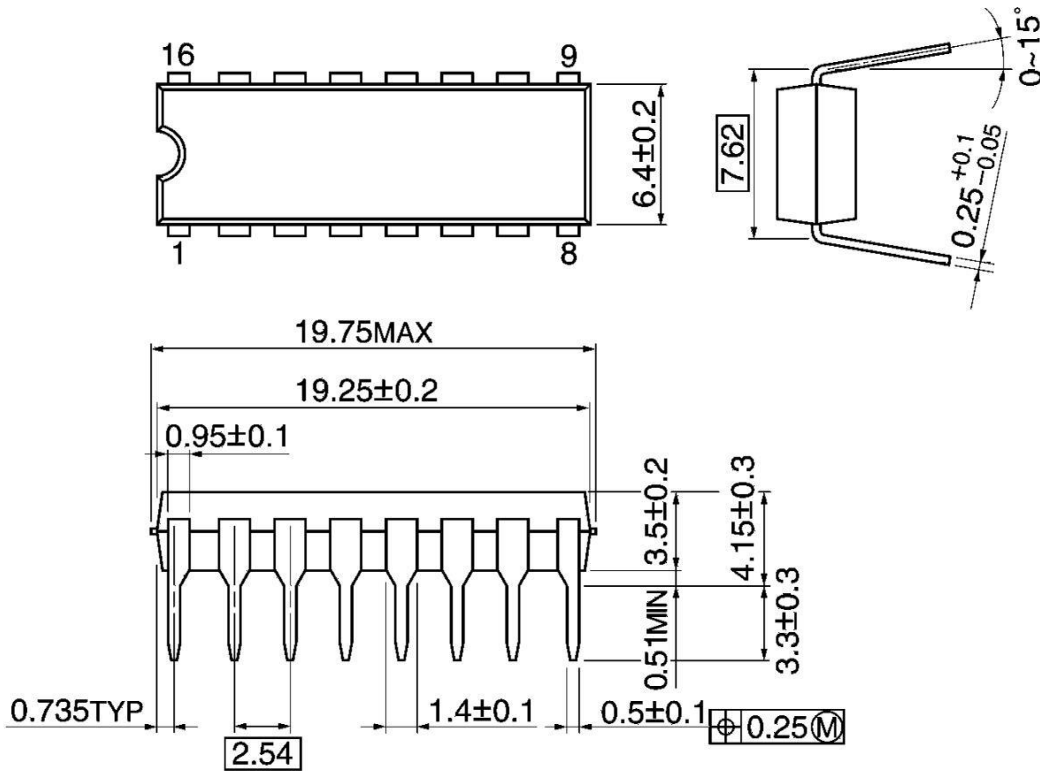

Weight: 1.11 g (Typ.)

SSOP16-P-225-0.65B

Unit: mm

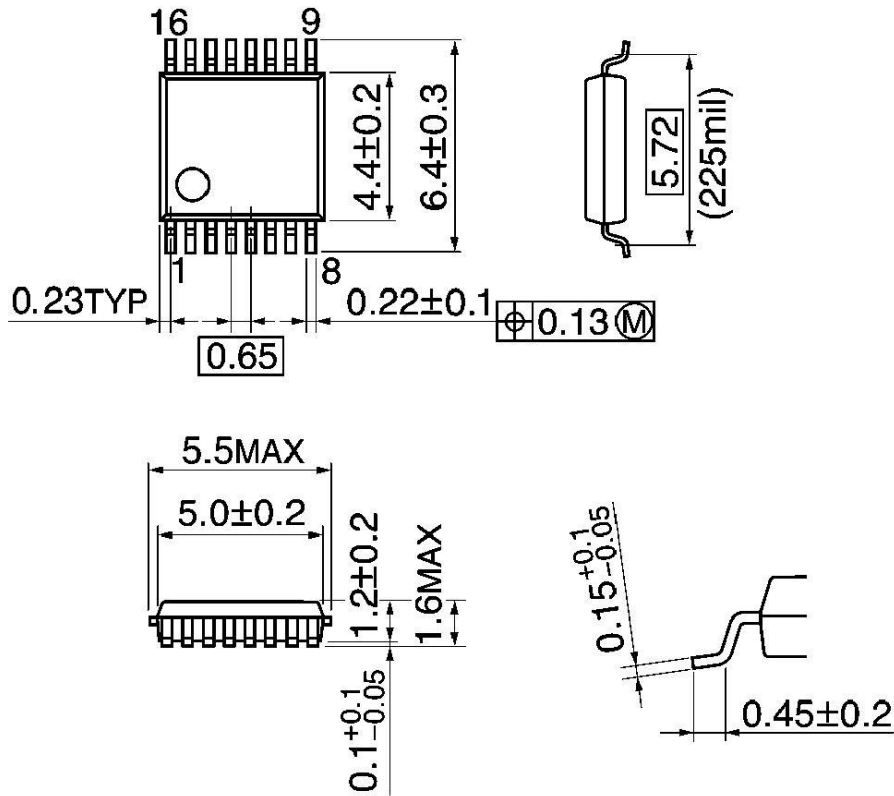

Weight: 0.07 g (Typ.)

P-SOP16-0410-1.27-002

Unit: mm

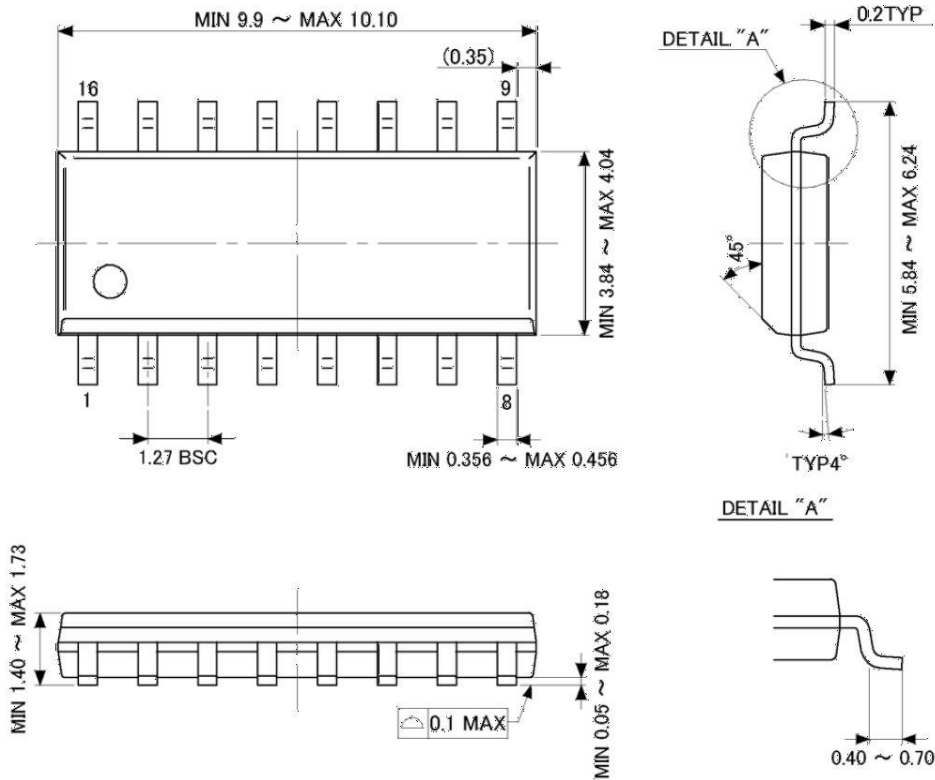

Weight: 0.15 g (Typ.)