

SPECIFICATION FOR APPROVAL

REF. :

PROD. NAME	SMD Power Inductor	ABC'S DWG NO.	SQ3225□□□□L□-□□□		
		REV.	20210123-K	PAGE	1

I . Configuration and dimensions :

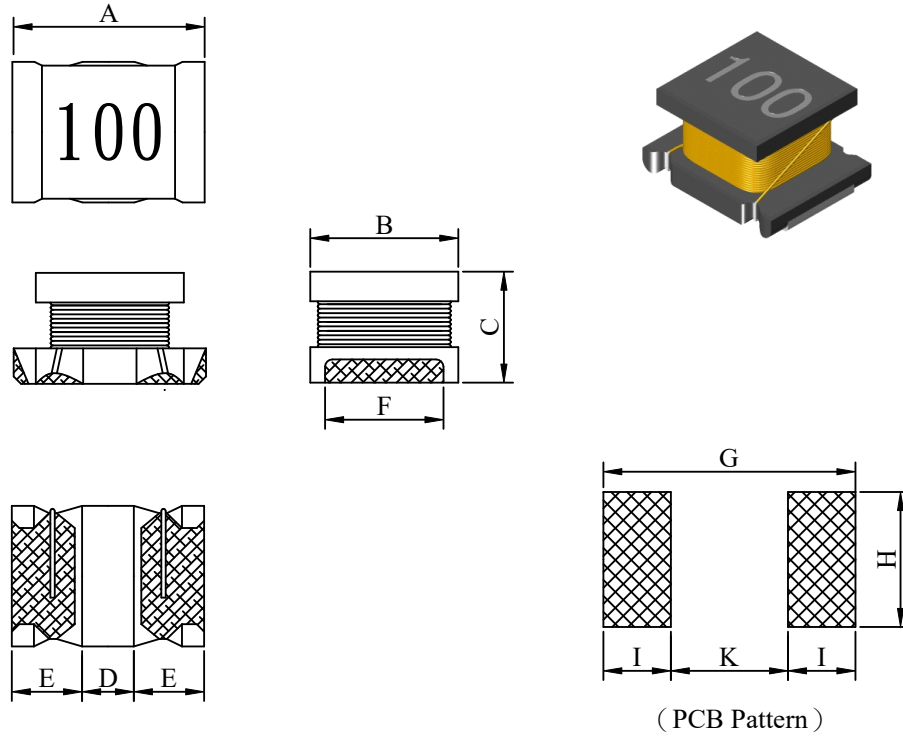

Unit : mm

A	B	C	D	E	F	G	H	I	K
3.20 ±0.3	2.50 ±0.3	2.00 ±0.3	1.30 typ.	1.20 ref.	1.20 ref.	3.80 ref.	2.80 ref.	1.40 ref.	1.00 ref.

II . Description :

- a . Ferrite drum core construction.
- b . Enamelled copper wire : H class
- c . Product weight : 0.046g (ref.)
- d . Moisture sensitivity Level 1
- e . Products comply with RoHS' requirements
- f . Halogen free

III . General specification :

- a . Storage temp. : -40°C ----+125°C
- b . Operating temp. : -40°C----+125°C
(Temp. rise included)
- c . Resistance to solder heat : 260°C.10 sec.

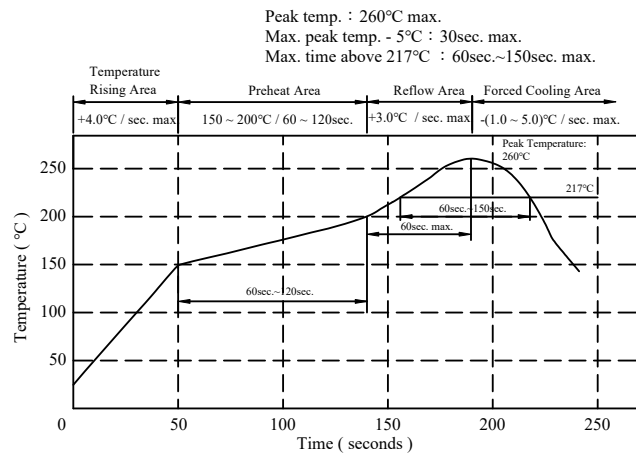

AR-001C

SPECIFICATION FOR APPROVAL

REF. :

PROD. NAME	SMD Power Inductor	ABC'S DWG NO.	SQ3225□□□□L□-□□□		
		REV.	20210123-K	PAGE	2

IV . Electrical characteristics :

DWG. No.	Inductance (μH)	Q ref.	Test Freq (Hz)		SRF (MHz) min.	RDC (Ω) max.	Irms 1 (mA)max. Δ T=20°C	Irms 2 (mA)max. Δ T=40°C
			L	Q				
SQ32251R0ML□-□□□	1.00 ±20%	20	1M	1M	100.0	0.10	600	750
SQ32251R2ML□-□□□	1.20 ±20%	20	1M	1M	100.0	0.12	580	720
SQ32251R5ML□-□□□	1.50 ±20%	20	1M	1M	75.0	0.13	560	660
SQ32251R8ML□-□□□	1.80 ±20%	20	1M	1M	60.0	0.14	520	640
SQ32252R2ML□-□□□	2.20 ±20%	20	1M	1M	50.0	0.15	480	620
SQ32252R7ML□-□□□	2.70 ±20%	20	1M	1M	43.0	0.18	430	600
SQ32253R3ML□-□□□	3.30 ±20%	20	1M	1M	38.0	0.20	400	580
SQ32253R9ML□-□□□	3.90 ±20%	20	1M	1M	35.0	0.25	360	540
SQ32254R7ML□-□□□	4.70 ±20%	20	1M	1M	31.0	0.28	330	490
SQ32255R6ML□-□□□	5.60 ±20%	20	1M	1M	28.0	0.36	300	440
SQ32256R8ML□-□□□	6.80 ±20%	20	1M	1M	25.0	0.40	280	420
SQ32258R2ML□-□□□	8.20 ±20%	20	1M	1M	23.0	0.45	260	390
SQ3225100KL□-□□□	10.00 ±10%	35	1M	1M	20.0	0.65	220	320
SQ3225120KL□-□□□	12.00 ±10%	35	1M	1M	18.0	0.70	200	290
SQ3225150KL□-□□□	15.00 ±10%	35	1M	1M	16.0	1.00	180	270
SQ3225180KL□-□□□	18.00 ±10%	35	1M	1M	15.0	1.10	170	240
SQ3225220KL□-□□□	22.00 ±10%	35	1M	1M	14.0	1.30	155	220
SQ3225270KL□-□□□	27.00 ±10%	35	1M	1M	13.0	1.60	130	165
SQ3225330KL□-□□□	33.00 ±10%	40	1M	1M	12.0	1.85	120	160
SQ3225390KL□-□□□	39.00 ±10%	40	1M	1M	11.0	2.00	115	152
SQ3225470KL□-□□□	47.00 ±10%	40	1M	1M	11.0	3.00	110	146
SQ3225560KL□-□□□	56.00 ±10%	40	1M	1M	10.0	3.20	105	138
SQ3225680KL□-□□□	68.00 ±10%	35	1M	1M	9.0	3.80	96	130
SQ3225820KL□-□□□	82.00 ±10%	35	1M	1M	8.5	5.60	85	105
SQ3225101KL□-□□□	100.00 ±10%	40	1M	796k	8.0	6.50	80	100
SQ3225121KL□-□□□	120.00 ±10%	40	1M	796k	7.5	7.00	75	95
SQ3225151KL□-□□□	150.00 ±10%	40	1M	796k	7.0	9.20	70	86
SQ3225181KL□-□□□	180.00 ±10%	40	1M	796k	6.0	10.20	65	80
SQ3225221KL□-□□□	220.00 ±10%	40	1M	796k	5.5	11.80	65	75
SQ3225271KL□-□□□	270.00 ±10%	40	1M	796k	5.0	14.80	60	70
SQ3225331KL□-□□□	330.00 ±10%	40	1M	796k	5.0	16.50	55	65
SQ3225391KL□-□□□	390.00 ±10%	46	1M	796k	5.0	22.00	50	60
SQ3225471KL□-□□□	470.00 ±10%	46	1k	796k	5.0	25.00	45	55
SQ3225561KL□-□□□	560.00 ±10%	46	1k	796k	5.0	28.00	40	48

- 1). Electrical specifications at 25°C
- 2). Inductance drop 10% max. at rated Irms

SPECIFICATION FOR APPROVAL

REF. :

PROD. NAME	SMD Power Inductor	ABC'S DWG NO.	SQ3225□□□□L□-□□□		
		REV.	20210123-K	PAGE	3

V . Curve :

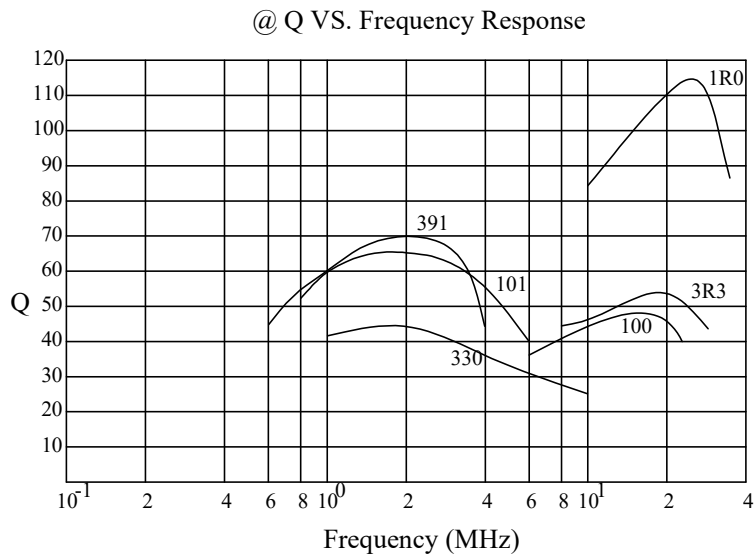
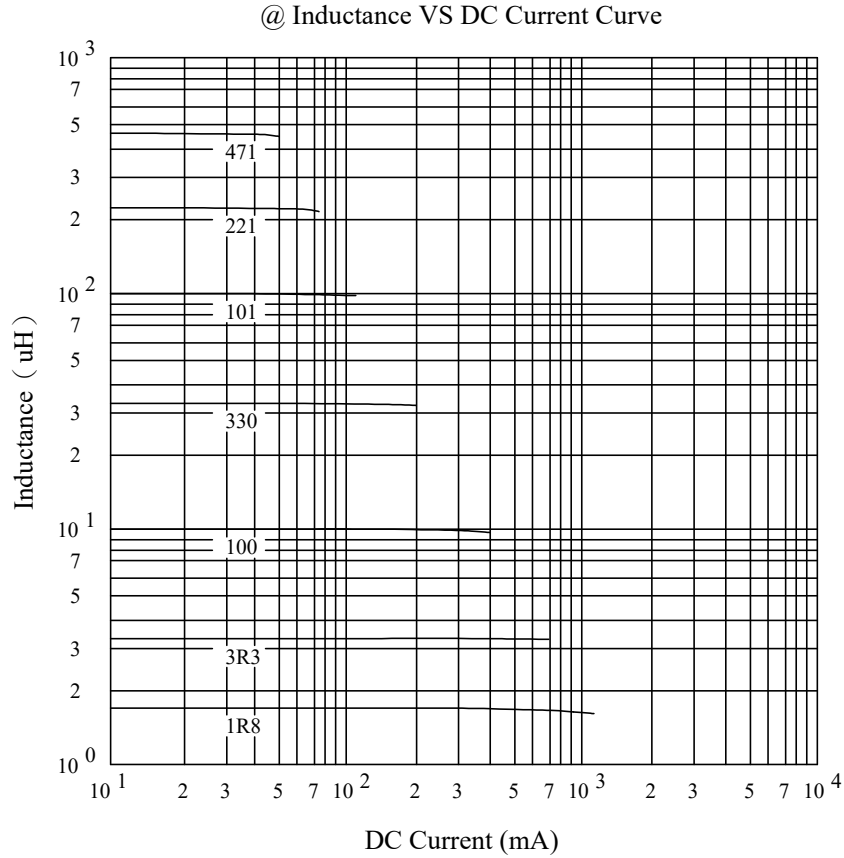

AR-001C

SPECIFICATION FOR APPROVAL

REF. :

PROD. NAME	SMD Power Inductor	ABC'S DWG NO.	SQ3225□□□□L□-□□□		
		REV.	20210123-K	PAGE	4

VI . Packaging information :

(1) Configuration

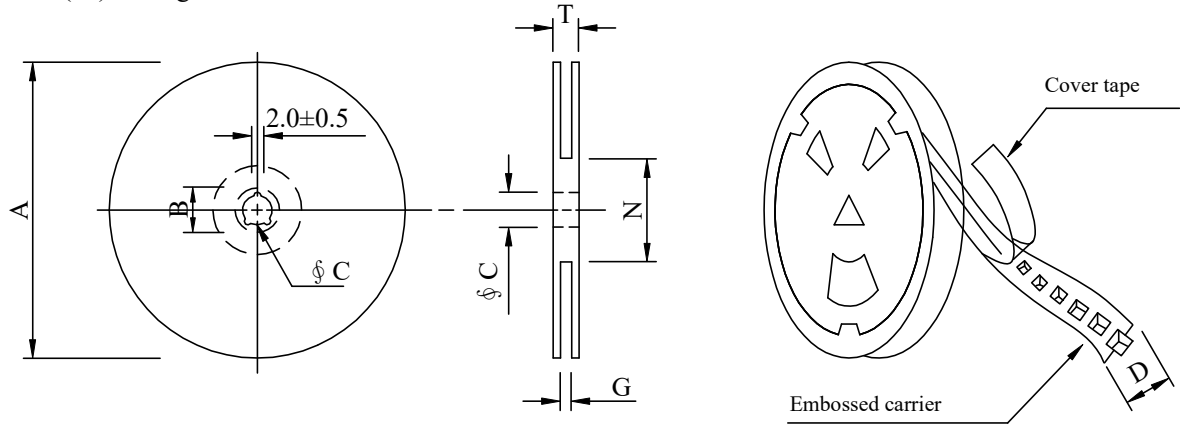

※Carrier tape width : D

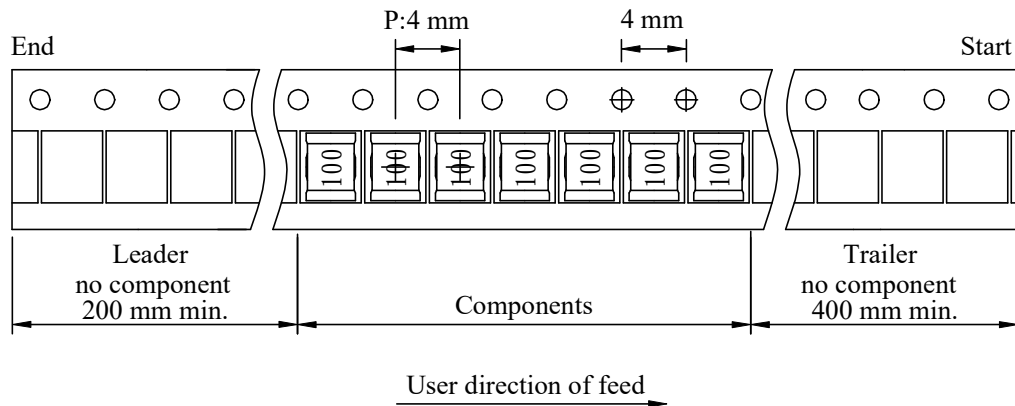

(2) Dimensions

Unit:mm

Style	A	B	C	D	G	N	T
07 - 08	178	21±0.8	13	8	10 ⁺⁰	50 ⁻⁰	12.5
07(S) - 08	183	21±0.8	13	8	10 ⁺⁰	50 ⁻⁰	12.5

(3) Q'TY & G.W. Per package

Code	Inner : Reel			Outer : Carton		
	Q'TY (PCS)	G.W. (g)	Style	Q'TY (pcs)	G.W. (kg)	Size (cm)
B	1,000	140	07 - 08	50,000	8.50	42 x 41 x 24
C	2,000	190	07(S) - 08	100,000	11.15	42 x 41 x 24

AR-001C

SPECIFICATION FOR APPROVAL

REF. :

PROD. NAME	SMD Power Inductor	ABC'S DWG NO.	SQ3225□□□□L□-□□□		
		REV.	20210123-K	PAGE	5

VII . Drawing number expression :

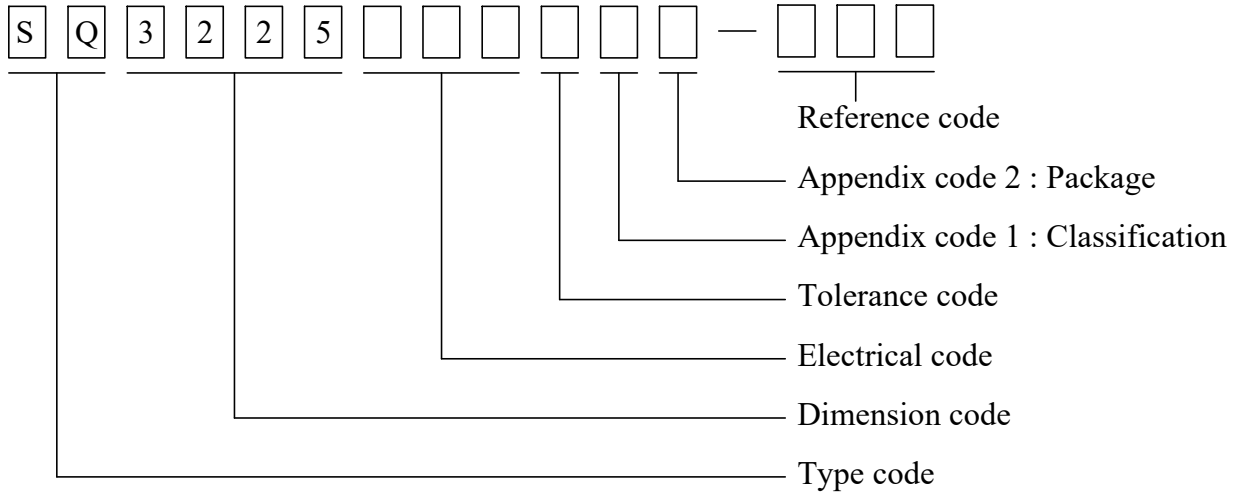

Appendix code 1 : Product Classification

Appendix code 2 : Package Information

Code	Inner package	Cover tape	Carrier tape	Bag	Package Q'TY	Remark
B	T /R (Reel package)	UCT	Non-antistatic	Antistatic	1,000 pcs	
C	T /R (Reel package)	UCT	Non-antistatic	Antistatic	2,000 pcs	

AR-001C

SPECIFICATION FOR APPROVAL

REF. :

PROD. NAME	SMD Power Inductor	ABC'S DWG NO.	SQ3225□□□□L□-□□□		
		REV.	20210123-K	PAGE	6

VIII . Reliability test :

Item	Reference documents	Test Condition	Test Specification
1.High Temperature Exposure	MIL-STD-202 Method 108	1.Temperature: 125±2°C 2.Time:96±2 hours.	1.No mechanical or electrical damage. 2.Inductance shall not change more than ±10%.
2.Temperature Cycling	JESD22-A 104	1.Temperature: -40°C ~ +125°C 2.Number of cycle:100 cycles. 3.Dwell time:30 minutes	1.No mechanical or electrical damage. 2.Inductance shall not change more than ±10%.
3.Biased Humidity Test	MIL-STD-202 Method 103	1.Temperature : 85±2 °C 2.Humidity: 85% RH. 3.Time:96±2 Hours	1.No mechanical or electrical damage. 2.Inductance shall not change more than ±10%.
4.Operational Life	JESD22-A 108	1.Temperature: 125°C(Temp. rise included) 2.Time:96±2 hours. 3.Rated current	1.No mechanical or electrical damage. 2.Inductance shall not change more than ±10%.
5.External Visual	JESD22-B 101 & MIL-STD-883 Method 2009	Inspect product constructions, marking and workmanship.	1.No pollution on the surface of products. 2.Clear marking. 3.No crack.
6.Physical Dimensions	JESD22-B 100	Verify physical dimensions to the applicable product detail specification.	Per product specification standard
7.Resistance to solvents	MIL-STD-202 Method 215	Immerse into solvent for 3±0.5 minutes & brush 10 times for 3 cycles.	1.No body change in appearance. 2.No marking blurred. 3.Inductance shall not change more than ±10%.
8.Vibration Test	MIL-STD-202 Method 204	1.Frequency and Amplitud : 10-2000-10 Hz, 1.5 mm. 2.Direction:X, Y, Z 3.Test duration:2 hours for each direction, 6 hours in total.	1.No mechanical or electrical damage. 2.Inductance shall not change more than ±10%.
9.Resistance To Soldering Heat Test	MIL-STD-202 Method 210 & J-STD020D.1	1.Highest temperature : 260±5°C. 2.Time (temp.≥ 217°C) : 60~150 Seconds. 3.IR reflow times : 3 times.	1.No mechanical or electrical damage. 2.Inductance shall not change more than ±10%.
10.Saturation Current	JIS C 6436 & User SPEC.	1.Applied rated current for 5 seconds. 2.Saturation current	Inductance shall not drop more than 10% max.
11.Over load	JIS C 6436 & User SPEC.	1.Applied one and half rated current for a period of 5 minutes. 2.Rated current	No electrical or mechanical damage
12.Temperature Rise Current	JIS C 6436 & User SPEC.	1.Applied rated current for 10 minutes. 2.Temperature measure by digital surface thermometer. 3.Irms current	Surface temperature rise is less than 40°C max.
13.Solderability Test	J-STD-002 & JESD22-B 102	1.Baking in pre-testing : 150±5°C / 16Hours±30 min. 2.Peak temperature : 240±5°C 3.Time (temp.≥ 217°C) : 60~150 seconds. 4.IR reflow times : 1 time.	More than 95% soldering coverage min on terminations.
14.Electrical Characteriazation	MIL-STD-202 Method 304 & User SPEC.	1.Operating temperature : -40°C~125°C 2.Room temperature : 25°C.	1.No mechanical or electrical damage. 2.Inductance shall not change more than ±10%.
15.Drop	CNS-C6354 & GB/T 2423.8	1.Products shall be mounted on SPEC. PCB and dropped down from a height of 1m 2.Drop total time : 6 time (Every side of sample drop 2 times)	1. Adhesion on PCB shall be enough. 2. Product appearance shall not break. 3. No electrical damage.
16.Terminal Strength Test	IEC 60068-2-21	1.Apply push force to samples mounted on PCB. 2.Force of 1.8 kg for 60±1 seconds.	After test, inductors shall be no mechanical damage.

AR-001C