

# PI3DBS12212A

## 3.3V, 1-12Gbps 1-Lane 2:1 Mux/De-Mux Switch

### Features

- 2 Differential Channel, 2:1 Mux/DeMux
- Up to 12 Gbps for applications including USB3.0, USB3.1, 10GE, Thunderbolt, and SAS3.0
- Bi-directional operation
- 3dB bandwidth: 10.6GHz
- Low Bit-to-Bit Skew, 1ps typ
- Low channel-to-channel skew, 7ps typ
- Low insertion loss: -1.5dB@5 GHz, -1.7dB@6 GHz
- Return loss: -19.6dB@5 GHz, -17.2dB@6 GHz
- Low Crosstalk: -30.5dB@6 GHz
- Low Off Isolation: -17.1dB@6 GHz
- Low power consumption - 200µA typ
- Supply Voltage 3.3V
- Industrial Temperature Range: -40oC to 85oC
- ESD – 2KV Human Body Model (HBM)
- Packaging (Pb-free & Green):
  - 20-contact, TQFN(ZB20), 2.5x4.5mm
  - 18 contact, X2QFN (XUA18), 2x2mm

### Block Diagram

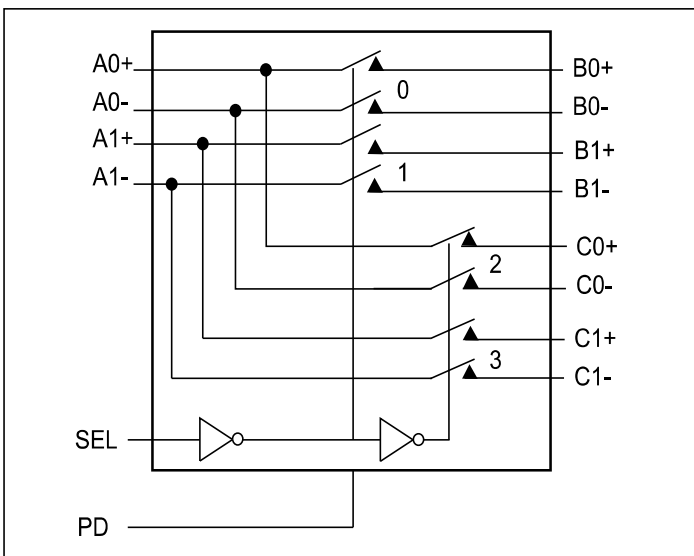

### Description

The PI3DBS12212A is an 4 to 2 differential channel multiplexer/demultiplexer switch. This solution can switch multiple signal types up to data rate of 12Gbps. Using a unique design technique, Diodes has been able to minimize the impedance of the switch such that the attenuation observed through the switch is minimal. The unique design technique also offers a layout targeted for USB3.0, USB3.1, 10GE, Thunderbolt, and SAS3.0 signals, which minimizes the channel to channel skew as well as channel to channel cross-talk as required by high speed signals.

### Applications

Routing high speed differential signals such as USB3.0, USB3.1, 10GE, Thunderbolt, and SAS3.0.

### Ordering Information

Part Number	Package	Description
PI3DBS12212AZBEX	ZB	20-Contact, Very Thin Quad Flat No-Lead (TQFN)
PI3DBS12212AXUAEX	XUA	18-Contact, 2x2mm (X2QFN)

Notes:

1. No purposely added lead. Fully EU Directive 2002/95/EC (RoHS), 2011/65/EU (RoHS 2) & 2015/863/EU (RoHS 3) compliant.
2. See <https://www.diodes.com/quality/lead-free/> for more information about Diodes Incorporated's definitions of Halogen- and Antimony-free, "Green" and Lead-free.
3. Halogen- and Antimony-free "Green" products are defined as those which contain <900ppm bromine, <900ppm chlorine (<1500ppm total Br + Cl) and <1000ppm antimony compounds.
4. E = Pb-free and Green
5. X suffix = Tape/Reel