

1. Scope :

This specification applies for the RL series of alloy film chip resistors made by TA-I.

2. Construction :

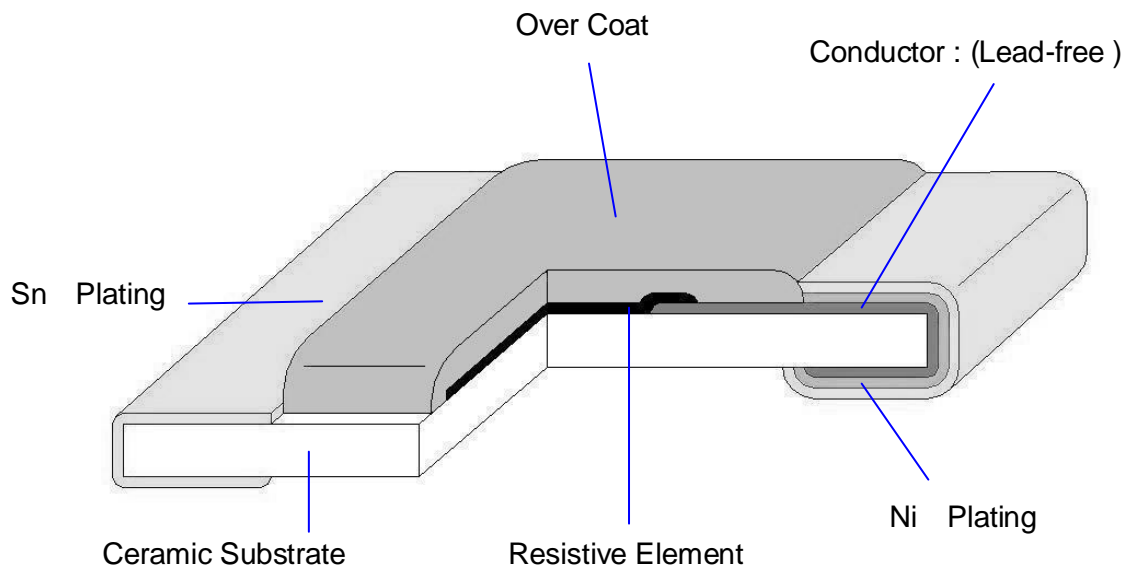

3. Type Designation :

RL

Product Code
RL : Chip Resistor

10

Size
Power Rating

F

Tolerance

TN

Packaging

R100

Nominal
Resistance

04-0402(1005) 1/16W
06-0603(1608) 1/8W
10-0805(2012) 1/4W
12-1206(3216) 1/2W
13-1210(3226) 1/2W
20-2010(5025) 3/4W
25-2512(6432) 1W

J- $\pm 5\%$
G- $\pm 2\%$
F- $\pm 1\%$

T-Paper Tape
E-Embossed Tape
N-Lead Free

3 Digits e.g.,5%
(E24) R10=0.1 Ω
4 Digits e.g.,1%
(E96) R100=0.1 Ω

4. Dimensions :

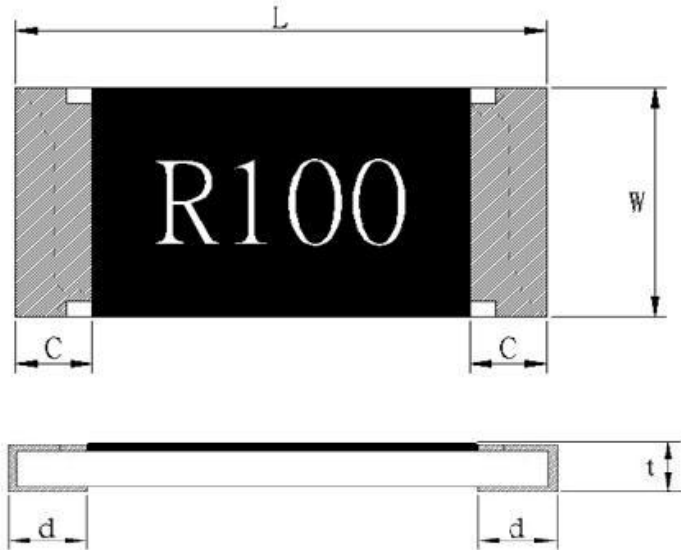

UNIT: mm

Type	L	W	C	d	t
RL04	1.00 $\begin{smallmatrix} +0.10 \\ -0.05 \end{smallmatrix}$	0.50 ± 0.05	0.20 ± 0.10	0.25 ± 0.10	0.35 ± 0.05
RL06	1.60 ± 0.10	0.80 ± 0.10	0.30 ± 0.20	0.35 ± 0.20	0.45 ± 0.10
RL10	2.00 ± 0.10	1.25 ± 0.10	0.40 ± 0.20	0.35 ± 0.20	0.50 ± 0.10
RL12	3.10 ± 0.20	1.55 ± 0.10	0.50 ± 0.30	0.40 ± 0.20	0.55 ± 0.10
RL13	3.10 ± 0.20	2.55 ± 0.20	0.50 ± 0.30	0.50 ± 0.20	0.55 ± 0.15
RL20	5.00 ± 0.20	2.50 ± 0.20	0.60 ± 0.30	0.50 ± 0.25	0.55 ± 0.10
RL25	6.30 ± 0.20	3.20 ± 0.20	0.60 ± 0.30	0.50 ± 0.25	0.55 ± 0.10

5. Electrical characteristics :

Characteristics	Feature							Measurement Method
	RL04	RL06	RL10	RL12	RL13	RL20	RL25	
Power Ratings (W)	1/16W	1/8W	1/4W	1/2W	1/2W	3/4W	1W	JIS Code 3A / JIS Code 3D
Resistance Value (m Ω)	100 ~ 910							Refer to JIS C 5201-1-4.5
T.C.R (ppm / $^{\circ}$ C)	100~500m Ω : ± 300 501~910m Ω : ± 200	± 200					Refer to JIS C 5201-1-4.8	
Operation Temperature Range($^{\circ}$ C)	-55 ~ +155							
Resistance Tolerance (%)	$\pm 1\%$, $\pm 2\%$, $\pm 5\%$							JIS C 5201-1-4.2.5
Insulation Resistance (M Ω)	Over 100							Refer to JIS C 5201-1-4.6
Maximum Working Voltage (V)	$(P * R)^{1/2}$							

Note : Except for the above standardized products, we also provide the customized products.

5.1 Derating Curve :

For resistors operated at ambient temperature over 70°C , power rating shall be derated in accordance with figure 1.

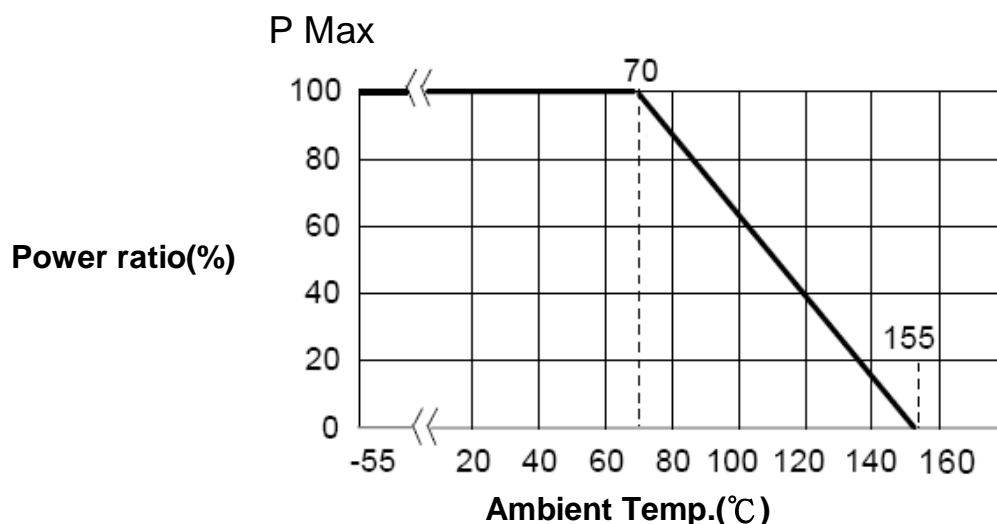

Figure 1

6. Reliability Test :

NTest Item	Reference standard	Condition of Test	Test Limits
Temperature Coefficient of Resistance	IEC60115-1-4.8 JIS-C5201-1-4.8	-55 ~ +125°C	Refer to paragraph 5
Short Time Overload	IEC60115-1-4.13 JIS-C5201-1-4.13	2.5 X rated voltage, 5s	1%:± (1%+0.005 Ω) 2%,5%:± (3%+0.005 Ω) Remark: 0402±(2%+0.005 Ω)
Load Life	IEC60115-1-4.25.1 JIS-C5201-1-4.25.1	1000 hours at rated power , 70°C , 1.5hours "ON " , 0.5hour "OFF"	1%:± (1%+0.001 Ω) 2%,5%:± (3%+0.001 Ω) Remark: 0402±(3%+0.005 Ω)
Load Life with Humidity	IEC60115-1-4.24 JIS-C5201-1-4.24	1000 hours at rated power , 40 ± 2°C , 90~95% RH 1.5hours "ON " , 0.5hour "OFF"	1%:± (1%+0.001 Ω) 2%,5%:± (3%+0.001 Ω) Remark: 0402±(3%+0.005 Ω)
Rapid Change of Temperature	IEC60115-1-4.19 JIS-C5201-1-4.19	-55°C (30 min.) / +155 °C (30 min.) 5 cycles	± 1%+0.005 Ω
Resistance to Soldering Heat	IEC60115-1-4.18 JIS-C5201-1-4.18	270 ± 5°C solder , 10 ± 1 sec dwell .	± 1%+0.005 Ω
Solderability	IEC60115-1-4.17 JIS-C5201-1-4.17	245±5°C solder, 2±0.5 sec dwell. Solder : Sn96.5 / Ag3.0 / Cu0.5	At least 95% of surface area of electrode shall be covered with new solder.
Robustness of Termination (Bending Strength)	IEC60115-1-4.33 JIS-C5201-1-4.33	3mm deflection 2mm deflection (RL20,25)	± 1%+0.005Ω
Resistance to Dry Heat	IEC60115-1-4.23.2 JIS-C5201-1-4.23.2	155 ± 5°C for 96 ± 4hrs	1%: ± (1%+0.005 Ω) 2%,5%:± (2%+0.005 Ω)

Note* :RCWV : Rated continuous working voltage .

7. Marking :

7.1 Type : 0805,1206,1210,2010,2512

7.1.1 E96: 1%

Resistance value is expressed by 4 digits, the first "R" means decimal point and the other digits represent for the normal resistance in Ω .

e.g., R100 = 100 m Ω

7.1.2 E24: 2%,5%

Resistance value is expressed by 3 digits, the first "R" means decimal point and the other digits represent for the normal resistance in Ω .

e.g., R10 = 100 m Ω

7.2 Type : 0603

7.2.1 E96: 1%

When the marking space is too small in such small-sized resistors as RL06, the marking can not made by 4 digits and may be made by two digits combined with one English capital.

Significant figures of nominal resistance

Symbol	E96	Symbol	E96	Symbol	E96	Symbol	E96
01	100	25	178	49	316	73	562
02	102	26	182	50	324	74	576
03	105	27	187	51	332	75	590
04	107	28	191	52	340	76	604
05	110	29	196	53	348	77	619
06	113	30	200	54	357	78	634
07	115	31	205	55	365	79	649
08	118	32	210	56	374	80	665
09	121	33	215	57	383	81	681
10	124	34	221	58	392	82	698
11	127	35	226	59	402	83	715
12	130	36	232	60	412	84	732
13	133	37	237	61	422	85	750
14	137	38	243	62	432	86	768
15	140	39	249	63	442	87	787
16	143	40	255	64	453	88	806
17	147	41	261	65	464	89	825
18	150	42	267	66	475	90	845
19	154	43	274	67	487	91	866
20	158	44	280	68	499	92	887
21	162	45	287	69	511	93	909
22	165	46	294	70	523	94	931
23	169	47	301	71	536	95	953
24	174	48	309	72	549	96	976

Symbol for multipliers

Symbol	A	B	C	D	E	F	G	H	X	Y	Z
multipliers	10 ⁰	10 ¹	10 ²	10 ³	10 ⁴	10 ⁵	10 ⁶	10 ⁷	10 ⁻¹	10 ⁻²	10 ⁻³

e.g., 01Z = 100 × 10⁻³ = 100 m Ω

Notes :

When the resistance value is not in the list of E96 , 3 digitals with underline in E-24 series is used as mark .

e.g., 0603 : 120m Ω , 1% Marking is 012

7.2.2 E24: 2%,5%

Resistance value is expressed by 3 digits, the first "0" means decimal point and the other digits represent for the normal resistance in Ω .

e.g., 010 = 100 m Ω

7.3 Type: 0402

RL04 : No Marking

8. Taping & Reel :

8.1 Taping Dimensions :

8.1.1 4 mm pitch paper

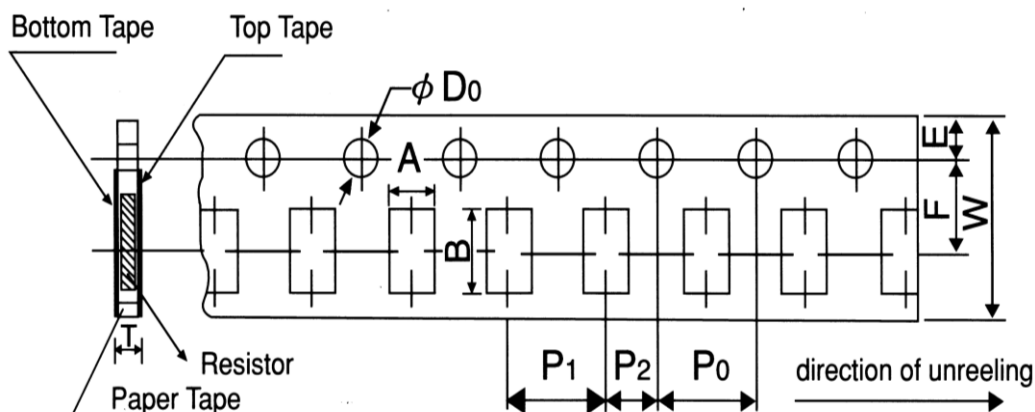

UNIT: mm

Packing	Type	A	B	W	F	E	P ₁	P ₂	P ₀	D ₀	T
Paper Tape	RL06	1.1 ±0.1	1.9 ±0.1	8.0±0.2	3.5±0.05	1.75±0.1	4.0±0.1	2.0±0.05	4.0±0.1	φ 1.5	0.64 ±0.1
	RL10	1.6 ±0.15	2.4 ±0.2								+0.1
	RL12	2.0 ±0.15	3.6 ±0.2								-0
	RL13	2.8±0.20	3.6±0.2								0.84 ±0.1

8.1.2 2 mm pitch paper :

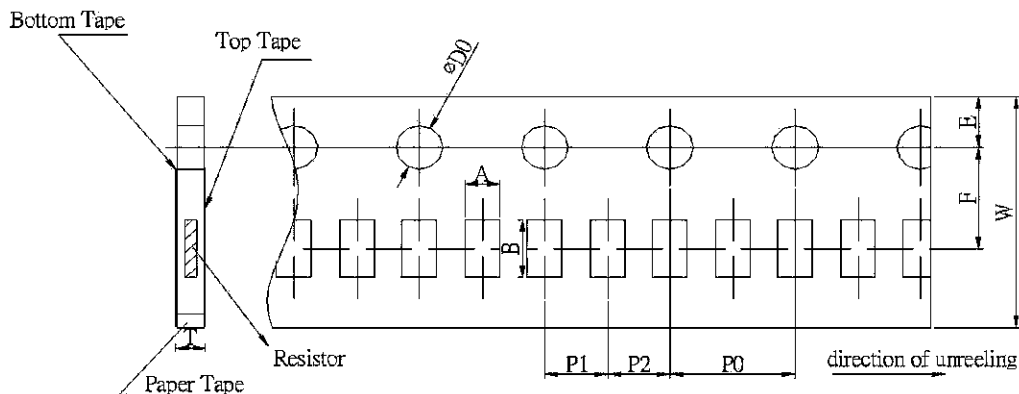

Packing	Type	A	B	W	F	E	P ₁	P ₂	P ₀	D ₀	T
Paper Tape	RL04	0.7±0.05	1.2±0.05	8.0 ±0.2	3.5±0.05	1.75±0.1	2.0 ±0.1	2.0 ±0.1	4.0 ±0.1	φ 1.5 +0.1 -0	0.45 ±0.1
	RL06	1.1 ±0.1	1.9 ±0.1	8.0 ±0.2	3.5±0.05	1.75±0.1	4.0 ±0.1	2.0 ±0.1	4.0 ±0.1	φ 1.5 +0.1 -0	0.64 ±0.1

8.1.3 4 mm pitch Emboss :

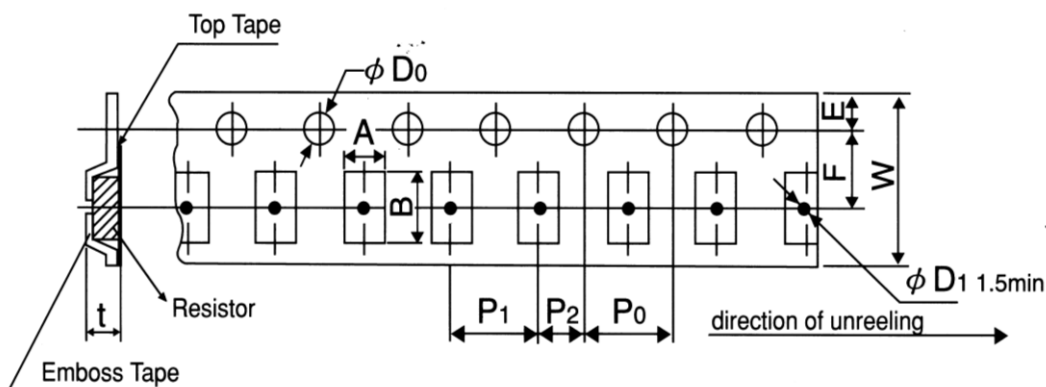

Packing	Type	A	B	W	F	E	P ₁	P ₂	P ₀	D ₀	T
Emboss	RL20	2.8 ±0.2	5.3 ±0.2	12.0±0.2	5.5±0.05	1.75±0.1	4.0±0.1	2.0±0.05	4.0±0.05	φ 1.5 +0.1 -0	0.85 ±0.15
	RL25	3.6 ±0.2	6.9 ±0.2								

Type Size		Paper Tape		Emboss Plastic Tape 4 mm pitch
		4 mm pitch	2 mm pitch	
		178mm/R	178mm/R	
RL	04		10000	
RL	06	5000	10000	
RL	10	5000		
RL	12	5000		
RL	13	5000		
RL	20			4000
RL	25			4000

8.2 Reel Specifications :

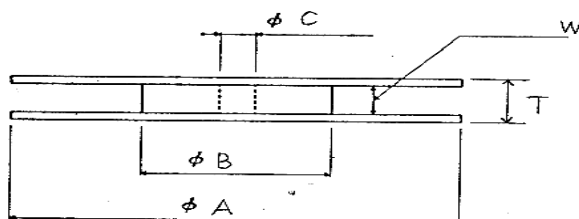
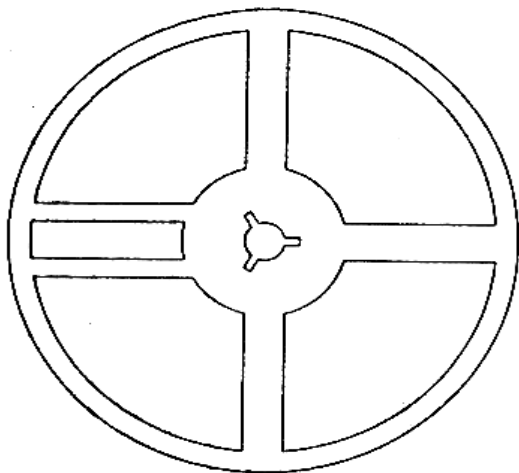

UNIT: mm

Series	ϕA	ϕB	ϕC	W	T
RL 04 /06 /10 /12 /13	178 ± 2.0	60.0 ± 1.0	13.0 ± 1.0	9.0 ± 1.0	11.5 ± 1.0
RL 20 / 25				13.0 ± 1.0	15.5 ± 1.0

8.3 Peel – off force :

Peel – off force of paper and blister tape is in accordance with “JIS-C5202 ” that is , 0.1 to 0.7 N at a peel-off speed of 300 mm / minute.

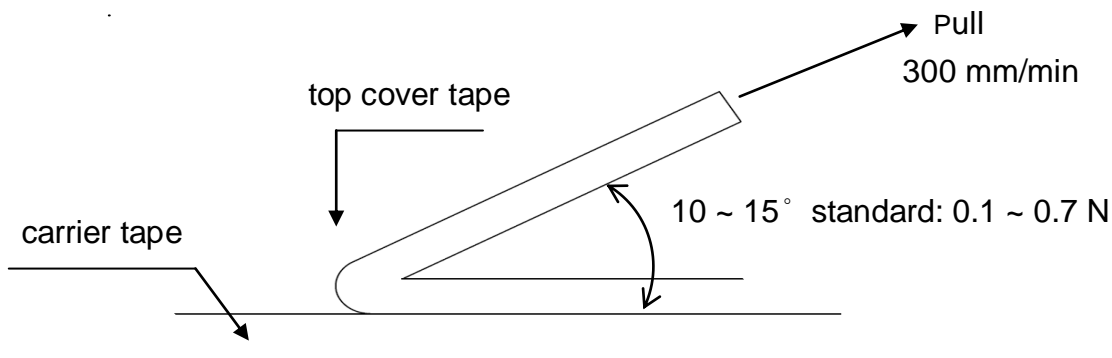

TA-I	Alloy Film Chip Resistors Low Resistance (Standard) Halogen-Free	Document No	TRL-XX0S002B
		Issued date	2020/03/18
		Page.	8 / 12

9. Label :

9.1 Manufacture Label :

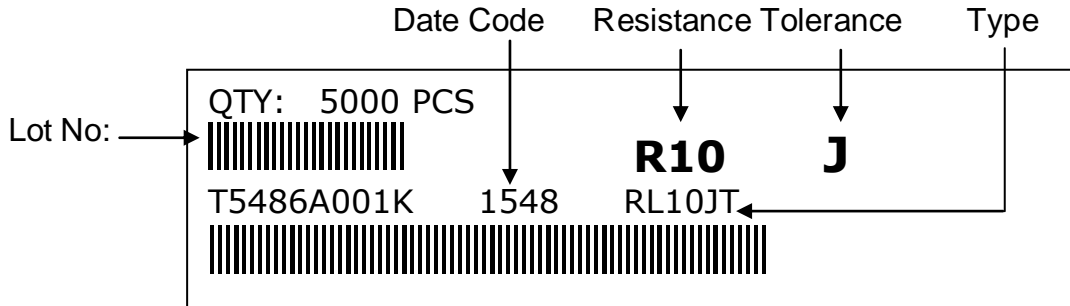

9.2 Customer Label: (By customer request) :



10. Recommended land patterns :

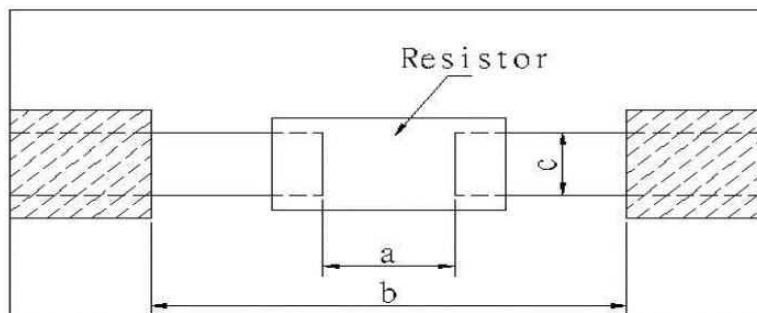

Type	Land pattern Size	Dimension (mm)		
		a	b	c
RL	04 (1005)	0.5~0.6	1.4~1.6	0.4~0.6
RL	06 (0603)	0.7~0.9	2.0~2.2	0.8~1.0
RL	10 (0805)	1.0~1.4	3.2~3.8	0.9~1.4
RL	12 (1206)	2.0~2.4	4.4~5.0	1.2~1.8
RL	13 (1210)	2.0~2.4	4.4~5.0	2.3~3.5
RL	20 (2010)	3.3~3.7	5.7~6.5	2.3~3.5
RL	25 (2512)	3.6~4.0	7.6~8.6	2.3~3.5

11. Recommend IR – Reflow profile : (Lead-Free solder : Sn96.5 / Ag3 / Cu0.5)

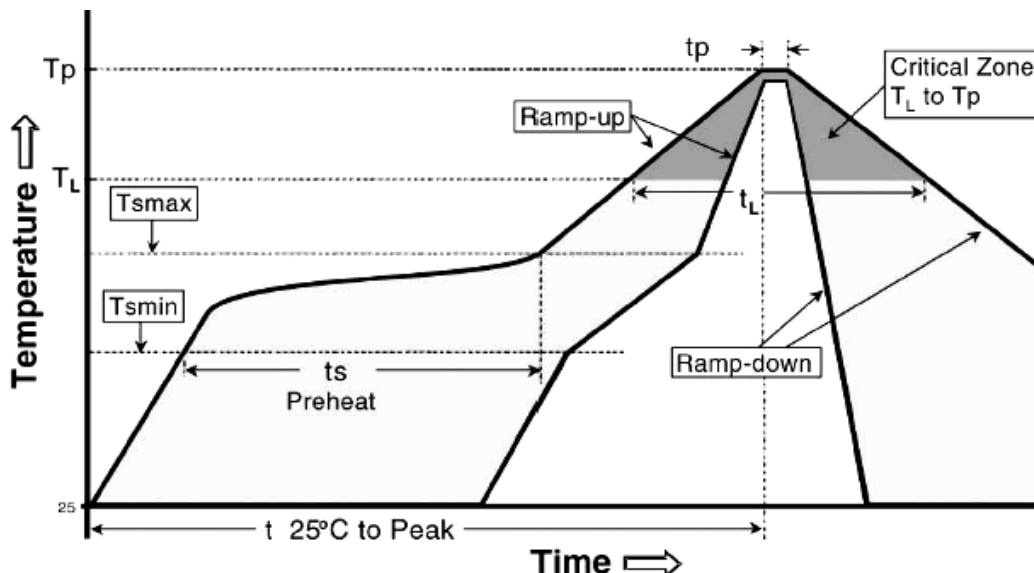

Profile Feature	Lead (Pb)-Free Assembly
Average ramp-up rate (T _{smax} to T _p)	3°C / second max.
Preheat - Temperature Min (T _{smin}) - Temperature Max (T _{smax}) - Time (T _{smin} to T _{smax}) (t _s)	150°C 200°C 60 -150 seconds
Time maintained above : - Temperature (T _L) - Time (t _L)	217°C 60-120 seconds
Peak Temperature (T _p)	260°C
Time within $\begin{matrix} +0 \\ -5 \end{matrix}$ °C of actual Peak Temperature (t _p) ²	10 seconds
Ramp-down Rate	6°C/second max.
Time 25°C to Peak Temperature	8minutes max.

Allowed Re-flow times : 3 times

Remark : To avoid discoloration phenomena of chip on terminal electrodes, please use N2 Re-flow furnace .

12. Storage Conditions :

Temperature: 5°C~35°C, Humidity:40%~75%

13. Shelf Life :

2 years from manufacturing date

TA-I	Alloy Film Chip Resistors Low Resistance (Standard) Halogen-Free	Document No	TRL-XX0S002B
		Issued date	2020/03/18
		Page.	10 / 12

14. ECN :

Engineering Change Notice: The customer will be informed with ECN if there is significant modification on the characteristics and materials described in Approval Sheet.

15. Manufacturing Country & City :

TA-I TECHNOLOGY CO., LTD. (Taiwan– Tao Yuan)
Tel: 886-3-3246169 Fax : 886-3-3246167

Associated companies :

(1) FORTUNE TASK RESISTOR FACTORY (China – Dongguan)
Tel : 86-769-8339-4790~3 Fax : 86-769-8339-4794

(2) TA-I TECHNOLOGY (DONGGUAN) CO., LTD. (China –Dongguan)
Tel : 86-769-8339-4790~3 Fax : 86-769-8339-4794

(3) TA-I TECHNOLOGY (SU ZHOU) CO., LTD. (China – Su Zhou)
Tel :86- 512-63457879 Fax : 86-512-63457869

(4) TAI OHM ELECTRONICS (M) SDN. BHD. (Malaysia – Penang)
Tel :604- 3900480 Fax : 604-3901481

(5) P.T.TAI ELECTRONICS Indonesia (Indonesia – Jakarta)
Tel :62-21-89830123 Fax : 62-21-89830703

TA-I	Alloy Film Chip Resistors Low Resistance (Standard) Halogen-Free	Document No	TRL-XX0S002B
		Issued date	2020/03/18
		Page.	11 / 12

Revise record

Date	Content	Owner
Dec.31, 2003	5.Electrical characteristics : TCR from ± 250 Change to ± 200 ppm/ $^{\circ}$ C	Wen Shen
Apr.16.2004	Adding JT/FT&JE/FE parts number	Wen Shen
Nov.22.2004	Adding RL04 size	Jeff Tian
May.18.2005	1. Adding "Recommend IR – Reflow profile" 2.Customer label adding "Lead-Free" 3.Modify Recommended land patterns 4.Adding shelf life	Hank Liu
Jul.10.2006	1. 2. Conductor : Adding to (Lead-free or with lead) 2. Sn/Pb Plating ,Sn Plating changed Sn Plating 3. 3. Type Designation: Adding to metric system 4. 6.Reliability Tests: Solderability : $235 \pm 5^{\circ}$ C solder, 2 ± 0.5 sec dwell. Changed to $245 \pm 5^{\circ}$ C solder, 2 ± 0.5 sec dwell. Solder : Sn96.5 / Ag3.0 / Cu0.5 5. 8.2 Reel Specifications: ϕ A $180+0 / -3.0$ changed 178 ± 2.0 ϕ B 60 min changed 60.0 ± 1.0 T 11.4 ± 2.0 changed 11.5 ± 1.0 15.4 ± 2.0 changed 15.5 ± 1.0 6. Delete RL04 size 7. 9.1 Manufacture label : Series number 3 codes changed to 4 codes 8. 15. Manufacturing Country & City: Adding TA-I TECHNOLOGY (DONGGUAN) CO., LTD	Vincent
Jan.30.2007	Adding " RL04 Specifications "	Vincent
March.10.2011	Reliability test : Reference standard from JIS-5202 change to IEC60115 & JIS-C5201	Kate
June 24.2011	Operating Temp($^{\circ}$ C): From -55° C ~ $+125^{\circ}$ C change to -55° C ~ $+155^{\circ}$ C	kate
June 19.2012	5.1 Derating Curve :	kate

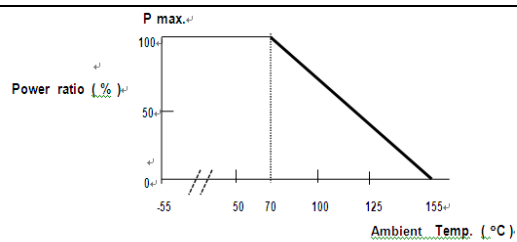
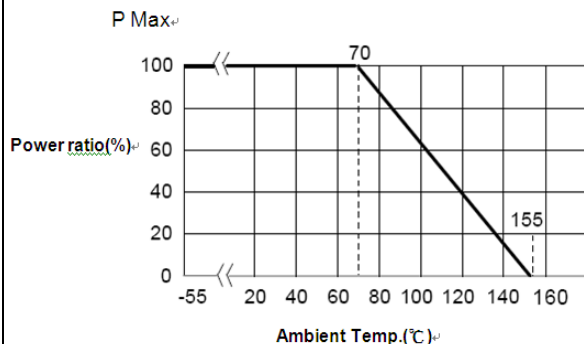

Figure 1

To exchange



	<p>Figure 1</p> <p>To exchange</p>	
July 12 .2012	<p>1. Adding Halogen-free words</p> <p>2. 11.Recommend IR – Reflow profile : Peak Temperature from 250°C to 260°C</p>	kate
Sep 21.2012	<p>6.Reliability test : Robustness of Termination (Bending Strength) : Adding 2mm deflection (RL20,25)</p>	ken
Jun 04.2013	<p>5. Electrical characteristics : RL04 resistance tolerance from 200~910mΩ to 100~910mΩ. RL04 TCR tolerance at 100~500mΩ is 300 ppm.</p>	ian
Aug 06.2014	<p>9.Label : Correct the resistance : from 0.01 Ω to R10</p>	ken
Aug.11.2016	<p>7. Marking Correct the Marking by RM E96</p>	soul
May 29.2019	<p>5. Electrical characteristics Add Type13</p>	Rebecca
Mar 18.2020	<p>5. Electrical characteristics Correct resistance : from 20~910mΩ to 100~910mΩ (RL13)</p>	Rebecca