

SOD-323

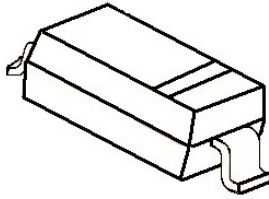

Marking: B5817WS: SJ

B5818WS: SK

B5819WS: SL

SOD-323 Plastic-Encapsulate Schottky Barrier Diode

特征 Features

- 大电流承受能力。High Current Capability
- 正向压降低。Low Forward Voltage Drop

机械数据 Mechanical Data

- 封装: SOD-323 封装 SOD-323 Small Outline Plastic Package
- 极性: 色环端为负极 Polarity: Color band denotes cathode end
- 安装位置: 任意 Mounting Position: Any

极限值和温度特性(TA = 25°C 除非另有规定)

Maximum Ratings & Thermal Characteristics (Ratings at 25°C ambient temperature unless otherwise specified.)

参数 Parameters	符号 Symbol	B5817WS	B5818WS	B5819WS	单位 Unit
最大可重复峰值反向电压 Maximum repetitive peak reverse voltage	VRRM	20	30	40	V
最大均方根电压 Maximum RMS voltage	VRMS	14	21	28	V
最大直流阻断电压 Maximum DC blocking voltage	VDC	20	30	40	V
最大正向平均整流电流 Maximum average forward rectified current	IFM	1.0			A
峰值正向浪涌电流 8.3ms 单一正弦半波 Peak forward surge current 8.3 ms single half sine-wave	IFSM	9			A
典型热阻 Typical thermal resistance	R θ JA	400			°C/W
功率消耗 Power Dissipation	PD	250			mW
工作结温 Operating junction temperature	Tj	125			°C
存储温度 Storage temperature range	TSTG	-50+150			°C

电特性 (TA = 25°C 除非另有规定)

Electrical Characteristics (Ratings at 25°C ambient temperature unless otherwise specified).

参数 Parameters	符号 Symbol	测试条件 Test conditions	B5817WS	B5818WS	B5819WS	单位 Unit
最大正向电压 Maximum forward voltage	V _F	IF = 1.0A IF = 3.0A	0.450 0.750	0.550 0.875	0.600 0.900	V
最大反向电压 Maximum reverse breakdown voltage	V _R	IR=1mA	20	30	40	V
最大反向电流 Maximum reverse current	I _R	VR=20V B5817WS VR=30V B5818WS VR=40V B5819WS	1.0			mA
典型结电容 Type junction capacitance	C _j	VR = 4.0V, f = 1MHz	120			pF

特性曲线 Characteristic Curves

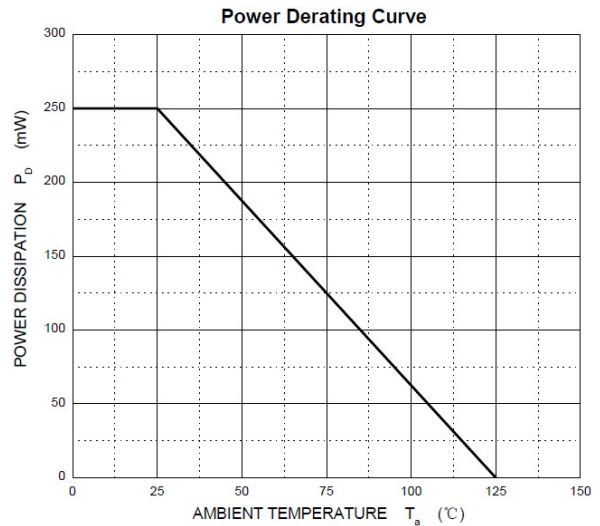
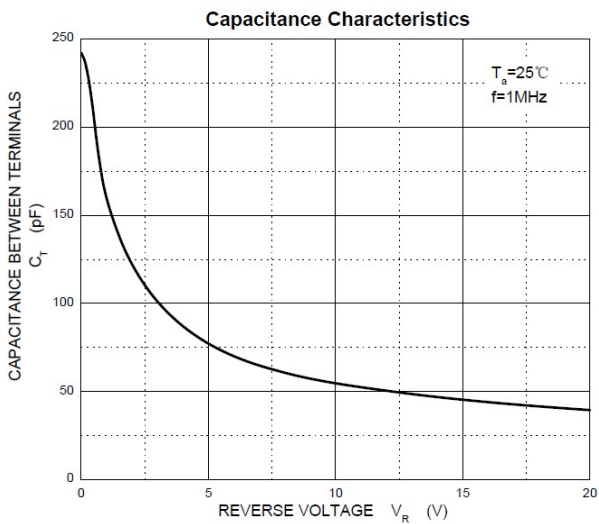
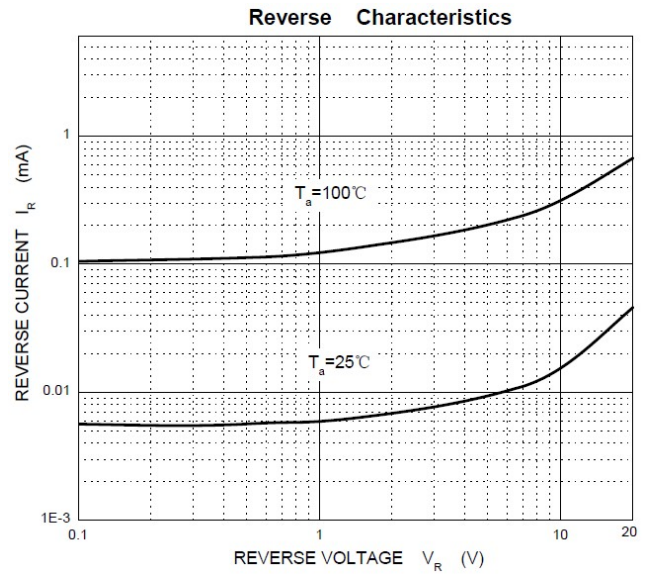
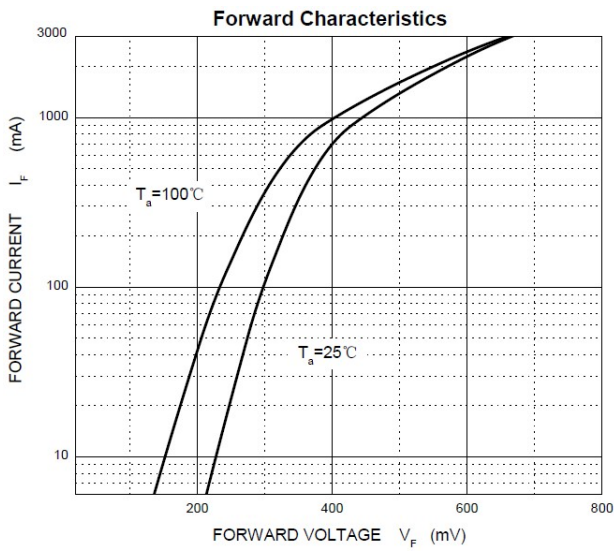

SOD-323 PACKAGE OUTLINE Plastic surface mounted package

SOD-323

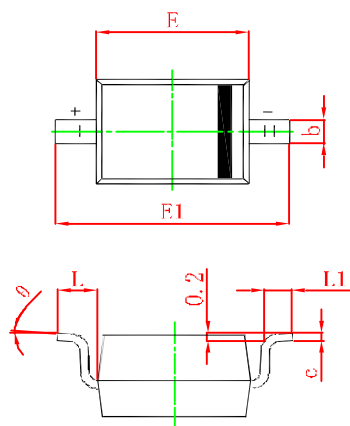

Symbol	Min.(mm)	Max.(mm)
A		1.000
A1	0.000	0.100
A2	0.800	0.900
b	0.250	0.350
c	0.080	0.150
D	1.200	1.400
E	1.600	1.800
E1	2.500	2.700
L	0.475REF	
L1	0.250	0.400
θ	0°	8°