

#### Features

- Ultra small package: SOD-323
- Ultra low leakage: nA level
- Low clamping voltage
- 2-pin leadless package
- RoHS compliant



#### IEC COMPATIBILITY (EN61000-4)

- IEC 61000-4-2 (ESD)  $\pm 30\text{kV}$  (air),  $\pm 30\text{kV}$  (contact)
- IEC 61000-4-5 (Lightning) 8A (8/20us)

#### Mechanical Characteristics

- Package: SOD-323
- Molding compound flammability rating: UL 94V-0
- Marking: Marking Code
- Packaging: Tape and Reel
- RoHS/WEEE Compliant
- MSD Level: 2

#### Applications

- Cellular Handsets and Accessories
- Personal Digital Assistants
- Notebooks and Handhelds
- Portable Instrumentation
- Digital Cameras
- Peripherals
- Audio Players
- Keypads, Side Keys, LCD Displays

#### Schematic and PIN Configuration

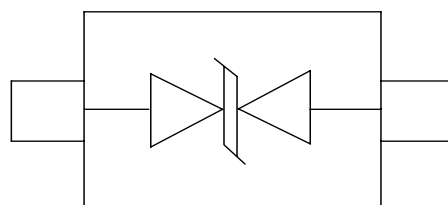

## Absolute Maximum Ratings (TA=25°C unless otherwise specified)

Rating	Symbol	Value	Units
Peak Pulse Power ( $t_p = 8/20\mu s$ )	$P_{PP}$	100	W
Peak Pulse Current ( $t_p = 8/20\mu s$ )	$I_{pp}$	8	A
ESD per IEC 61000-4-2(Air)	$V_{ESD}$	$\pm 30$	kV
ESD per IEC 61000-4-2(contact)		$\pm 30$	
Operating Temperature	$T_J$	-55 to + 125	°C
Storage Temperature	$T_{STG}$	-55 to +150	°C

## Portion Electronics Parameter

Symbol	Parameter
$I_T$	Test Current
$I_{PP}$	Maximum Reverse Peak Pulse Current
$V_C$	Clamping Voltage @ $I_C$

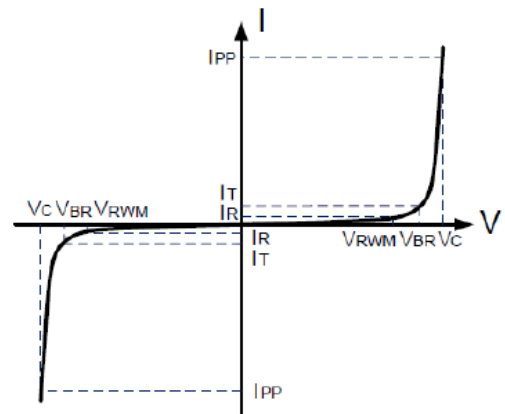

## Electrical Characteristics (TA=25°C unless otherwise specified)

Parameter	Symbol	Conditions	Min	Typical	Max	Units
Reverse Stand-Off Voltage	$V_{RWM}$				5.0	V
Reverse Breakdown Voltage	$V_{BR}$	$I_T = 1mA$	6.0			V
Reverse Leakage Current	$I_R$	$V_{RWM} = 5.0V$			0.5	$\mu A$
Clamping Voltage	$V_C$	$I_{PP} = 1A, t_p = 8/20\mu s$			7.5	V
		$I_{PP} = 8A, t_p = 8/20\mu s$			12	V
Junction Capacitance	$C_j$	$V_R = 0V, f = 1MHz$		15	18	pF

## Typical Characteristics(TA=25°C unless otherwise Specified)

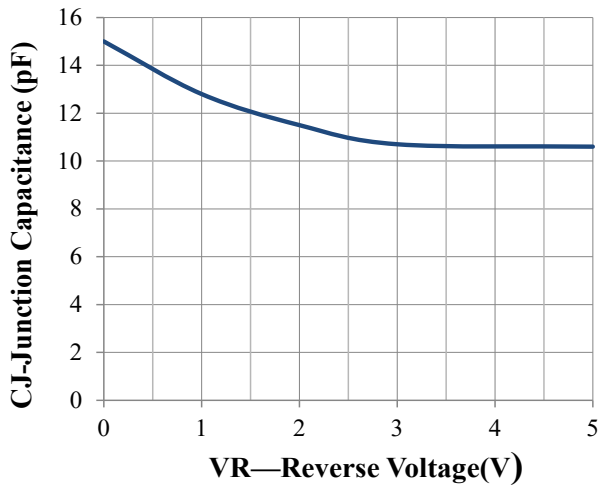

Junction Capacitance vs. Reverse Voltage

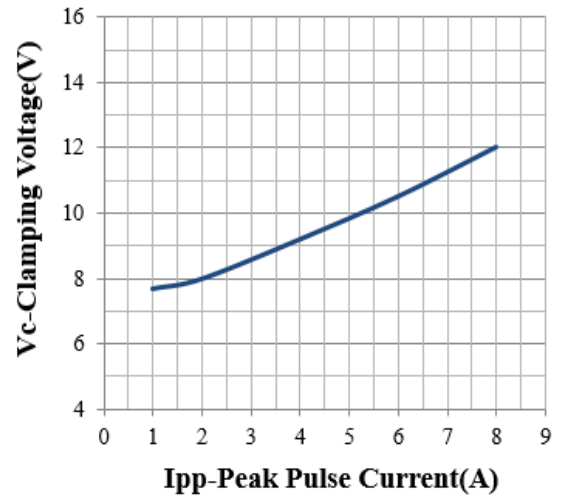

Clamping Voltage vs. Peak Pulse Current

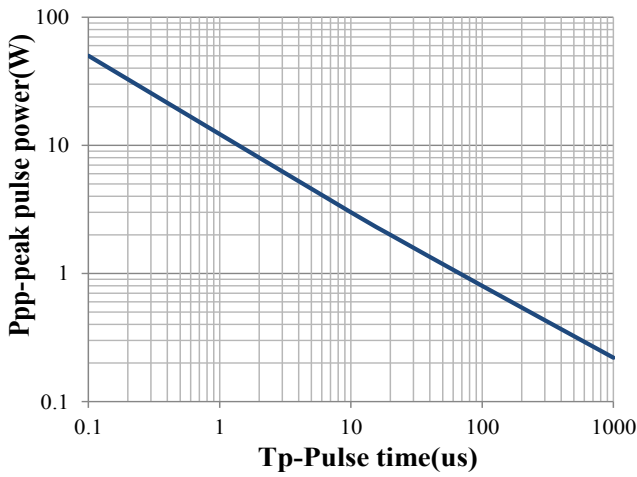

Peak Pulse Power vs. Pulse Time

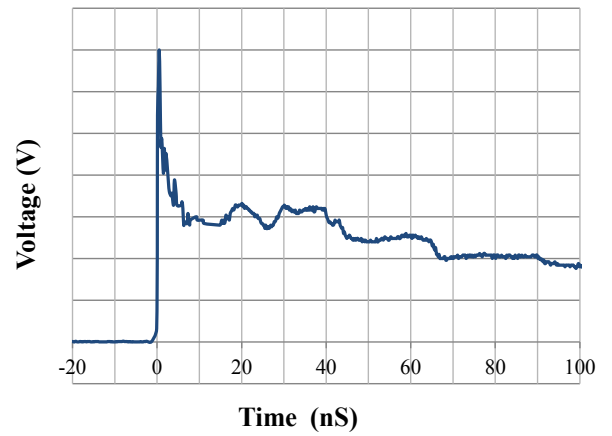

IEC61000-4-2 Pulse Waveform

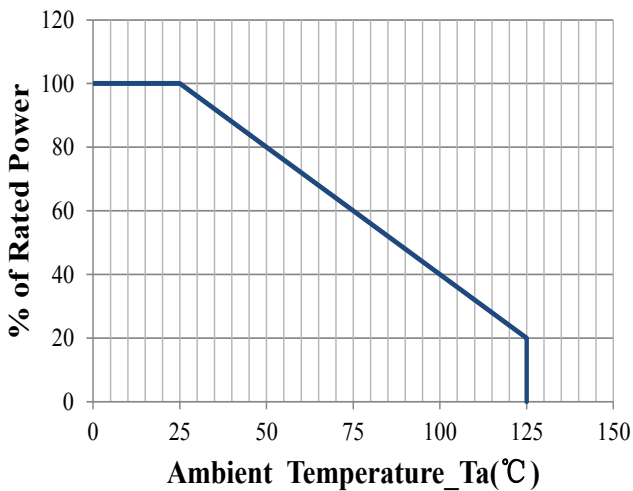

Power Derating Curve

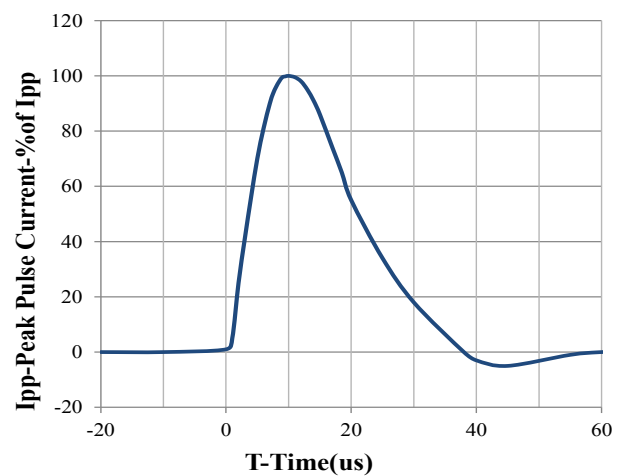

8 X 20us Pulse Waveform

## SOD-323 Package Outline Drawing

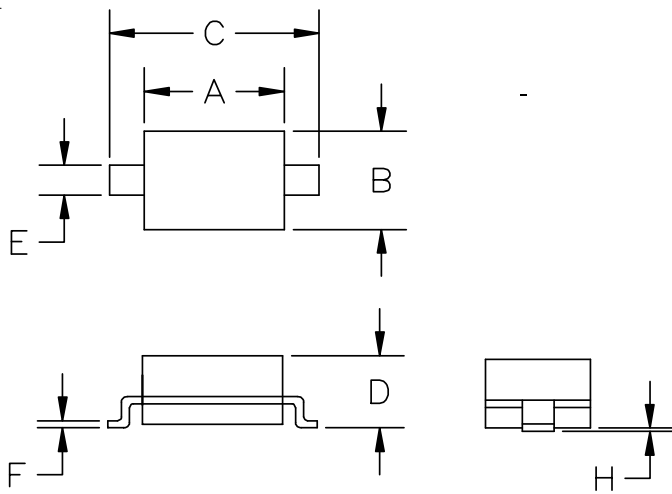

SYM	DIMENSIONS			
	MILLIMETERS		INCHES	
	MIN	MAX	MIN	MAX
A	1.50	1.80	0.060	0.071
B	1.20	1.40	0.045	0.054
C	2.30	2.70	0.090	0.107
D	-	1.10	-	0.043
E	0.30	0.40	0.012	0.016
F	0.10	0.25	0.004	0.010
H	-	0.10	-	0.004

## Suggested Land Pattern

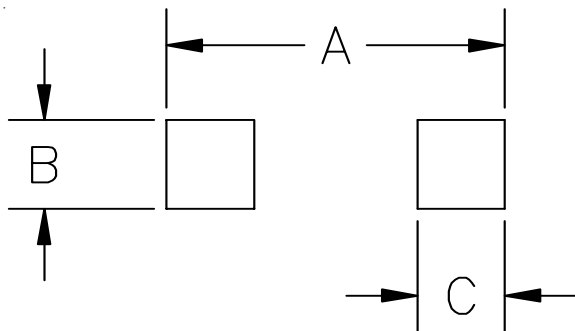

SYM	DIMENSIONS	
	MILLIMETERS	INCHES
A	3.15	0.120
B	0.80	0.031
C	0.80	0.031

## Order Information

Order code	Package	Packaging	Reel Size
MSD3C051VA	SOD-323	3000/Tape & Reel	7 inch