

SCOPE

This specification is applied to electrostatic discharge (ESD) protection. It is designed to protect the high-speed data lines against ESD transients. It has very low capacitance and fast turn on times makes it ideal for data and transmission lines with high data rates. We don't recommend use it in power line, SD/TF Card, button board and LVDS port.

FEATURES

- Low capacitance (0.2pF typical)
- Bi-directional ESD protection
- Lead free solder termination
- The best ESD protection for high frequency, low voltage applications
- Zero signal distortion

CONSTRUCTION

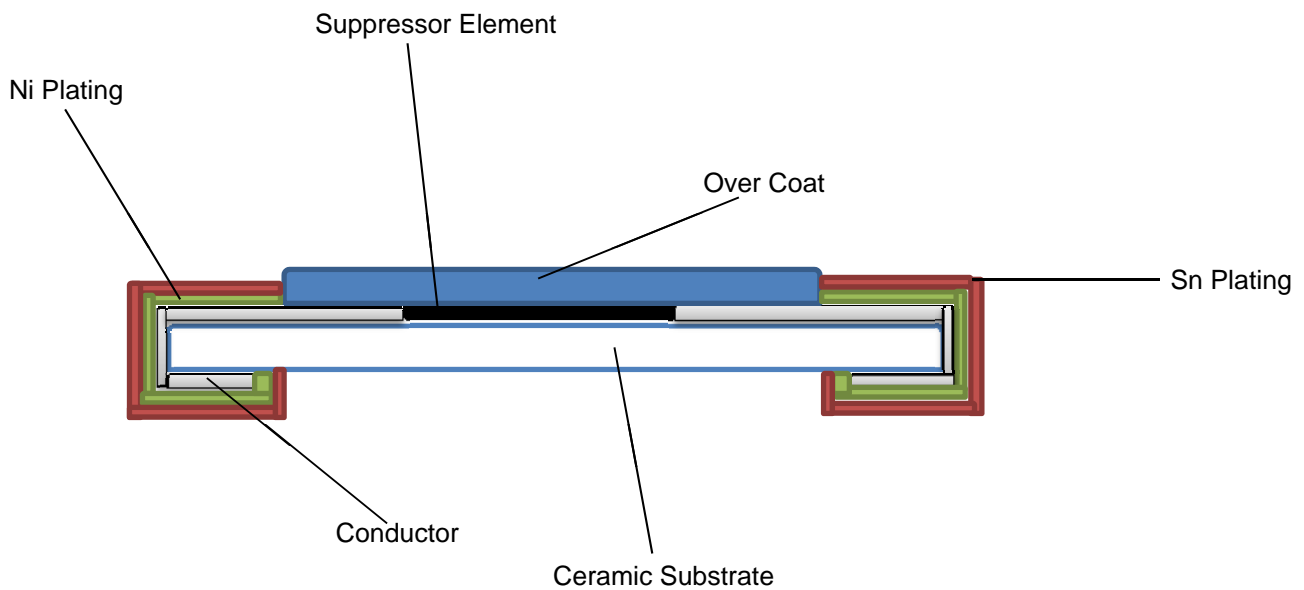

Explanation of Part Number

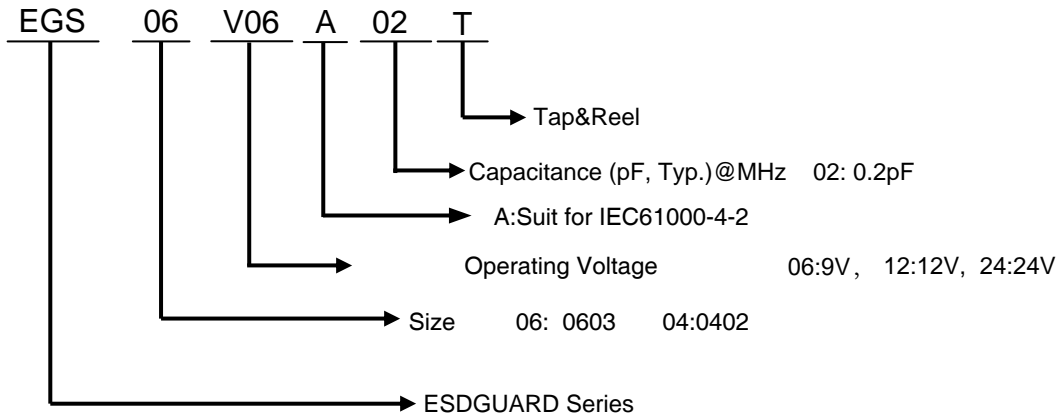

Rating and Characteristics

Part No.	Working Voltage	Typical ESD Trigger Voltage	Typical ESD Clamping Voltage at 30ns	Leakage Current (at Initial State)	Leakage Current (after ESD Test)	Cap. Value at 1MHz
Symbol	$V_{DC(max.)}$	$V_{trigger(typ.)}$	$V_C(typ.)$	I_{LDC}	I_{LDCA}	C
Unit	V	V	V	μA	μA	pF
EGS04V06A02T	6	300	30	<0.05	<10	0.20pF (max. 0.30pF)
EGS04V12A02T	12	300	30	<0.05	<10	0.20pF (max. 0.30pF)
EGS04V24A02T	24	300	30	<0.05	<10	0.20pF (max. 0.30pF)
EGS06V06A02T	6	300	30	<0.05	<10	0.20pF (max. 0.40pF)
EGS06V12A02T	12	300	30	<0.05	<10	0.20pF (max. 0.40pF)
EGS06V24A02T	24	300	30	<0.05	<10	0.20pF (max. 0.40pF)

Note:

- * 1 The clamping voltage was measured by IEC61000-4-2 level 4, direct discharge 8KV.
- * 2 The leakage current was measured at V_{DC} .
- * 3 The components shall be employed within 1 year, in the nitrogen condition.

Dimensions

Model	0402(1005)	0603(1608)
Length(L)	1.00±0.10	1.60±0.15
Width(W)	0.50±0.10	0.80±0.10
Thickness(T)	0.60 max.	0.90 max.
Termination(a)	0.25±0.10	0.30±0.10

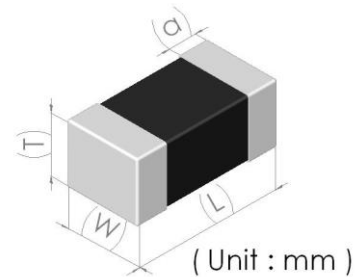

Recommended solder pad layout

(Unit : mm)

	A	B	C
0402	0.4~0.6	0.6~0.9	0.5~0.7
0603	0.9~1.2	0.9~1.2	0.8~1.0

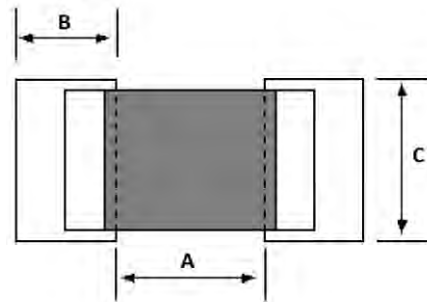

Reliability Test

Characteristic	Test Method and Description			
High Temperature Storage	The specimen shall be subjected to 125±2°C for 1000±2 hours without load and then stored at room temperature and normal humidity for one or two hours. The change of varistor voltage shall be within 10%.			
Temperature Cycle	The temperature cycle of specified temperature shall be repeated five times and then stored at room temperature and normal humidity for one or two hours. The change of varistor voltage shall be within 10% and mechanical damage shall be examined.	Step	Temperature	Period
		1	-40±3°C	30±3min
		2	room temperature	1 hour
		3	125±3°C	30±3min
4	room temperature	1 hour		
High Temperature Load	After being continuously applied the maximum allowable voltage at 85±2°C for 1000±2 hours, the specimen shall be stored at room temperature and normal humidity for one or two hours. The change of varistor voltage shall be within 10%.			
Damp Heat Load/ Humidity Load	The specimen should be subjected to 40±2°C and 90~95% RH, the maximum allowable voltage applied for 1000±2 hours and then stored at room temperature and normal humidity for one or two hours. The change of varistor voltage shall be within 10%.			
Low Temperature Storage	The specimen should be subjected to -40±2°C for 1000±2 hours without load and then stored at room temperature and normal humidity for one or two hours. The change of varistor voltage shall be within 10%.			

Taping and Reel

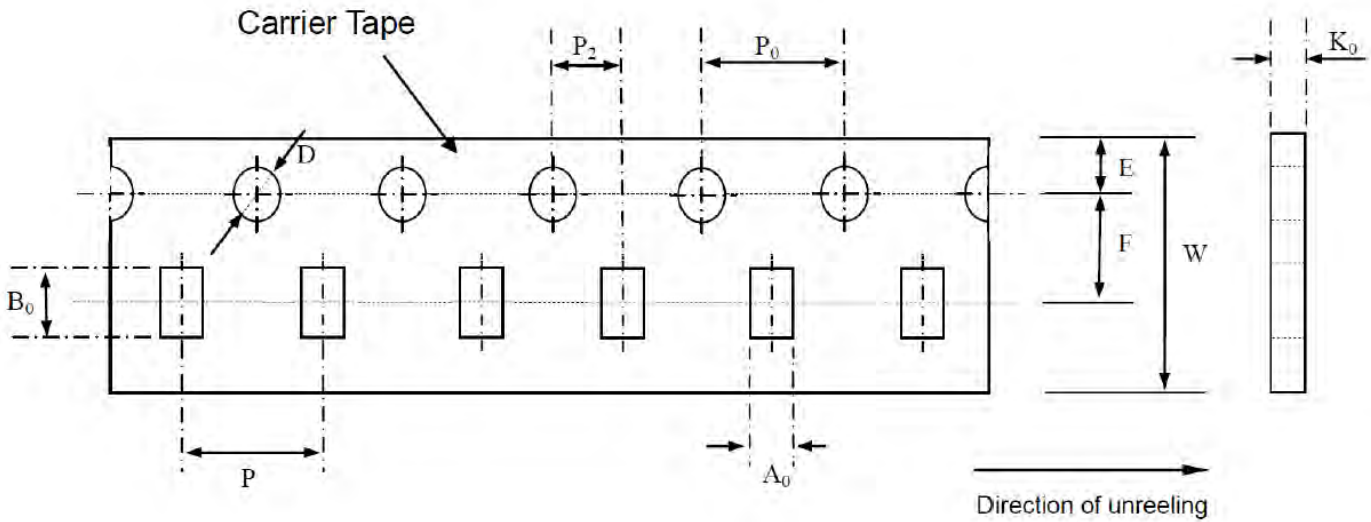
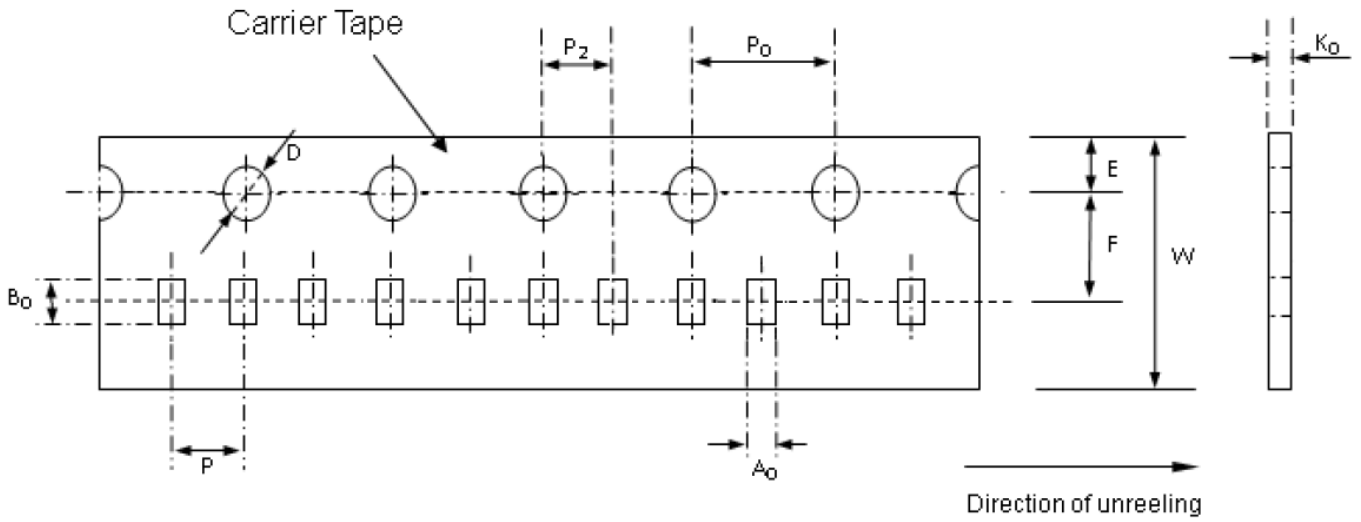

(Unit : mm)

Symbol	A_0 ± 0.05	B_0 ± 0.05	K_0 ± 0.05	D $+0.10$ -0.05	P ± 0.10	P_2 ± 0.10	P_0 ± 0.10	W ± 0.10	E ± 0.10	F ± 0.05
0402	0.62	1.12	0.60	1.55	2.00	2.00	4.00	8.00	1.75	3.50
0603	1.10	1.90	0.95	1.56	4.00	2.00	4.00	8.00	1.75	3.50

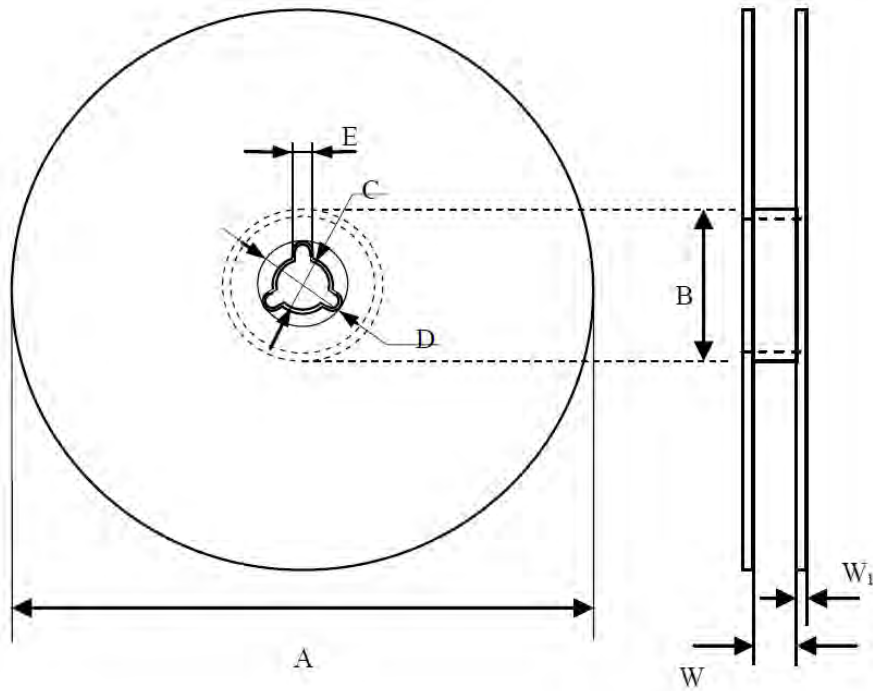

(Unit : mm)

Symbol	A	B	C	D	E	W	W ₁
0402	178.0±1.0	60.0±0.5	13.0±0.2	21.0±0.2	2.0±0.5	9.0±0.5	1.5±0.1
0603	178.0±1.0	60.0±0.5	13.0±0.2	21.0±0.2	2.0±0.5	9.0±0.5	1.5±0.1

Storage Conditions

Shelf Life

Storage Conditions : Temperature: 5°C~35°C, Humidity: 40%~75%

Shelf Life : 2 years from manufacturing date

Recommendable reflow soldering

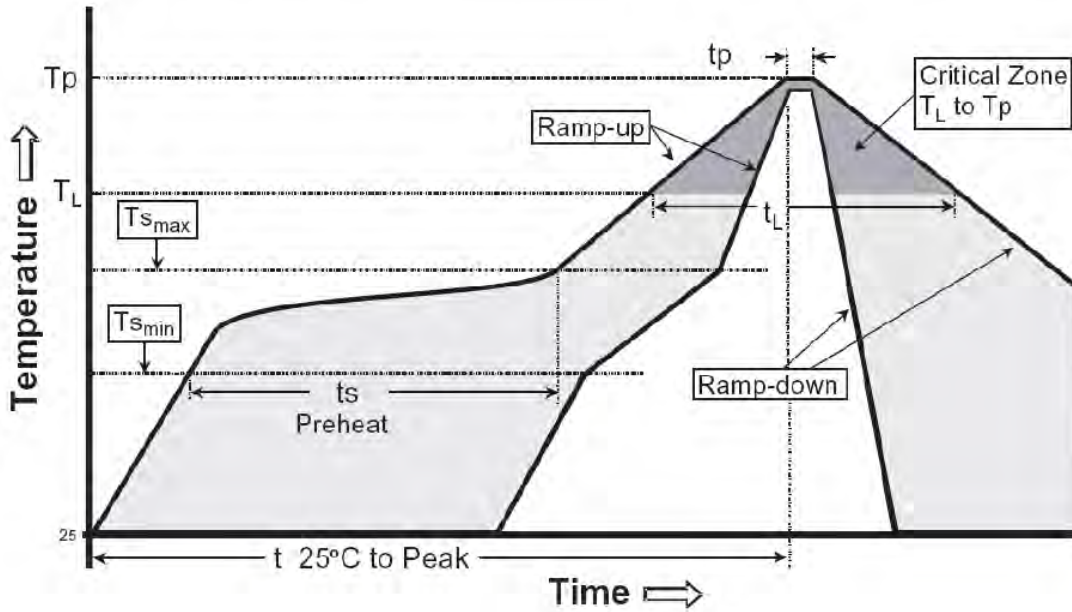

Reference IPC-020c-5-1

Profile Feature	Pb free Assembly
Average Ramp Rate (Ts max to Tp)	5 °C/second max
Preheat	
- Temperature Min (Ts _{min})	150°C
- Temperature Min (Ts _{max})	180°C
- Time(ts _{min} to ts _{min})	60-120 seconds
Time maintained above:	
- Temperature (T _L)	230°C
- Time (t _L)	60-150 seconds
Peak Temperature (T _p)	250°C +0/-5 °C
Time within 5 °C of actual Peak Temperature (T _p)	20-40 seconds
Ramp-Down Rate	6 °C/second max.
Time 25°C to Peak Temperature	8 minutes max