

# 1.0MHz, 2A Synchronous Step-Down LED Driver

## FEATURES

- 1.0MHz Constant Frequency Operation
- Up to 2.0A LED Current
- No Schottky Diode Required
- 2.5V to 5.5V Input Voltage Range
- Feedback Voltage as Low as 0.1V
- 100% Duty Cycle in Dropout
- Low Quiescent Current: 50 $\mu$ A
- Short Circuit Protection
- Thermal Fault Protection
- Input over voltage protection (OVP)
- <1 $\mu$ A Shutdown Current
- SOT23-5 Package

## GENERAL DESCRIPTION

The TMI5102 is a constant frequency, current mode PWM step-down LED driver with 2A output current and 1.0MHz switch frequency. The device integrates a main switch and a synchronous rectifier for high efficiency without an external Schottky diode. This device offers two operation modes, PWM control and PFM Mode switching control, which allows a high efficiency over the wider range of the LED current. The feedback voltage is 0.1V typically. The device also integrates many protection features included input OVP, cycle-by-cycle current limit, over temperature protection.

## APPLICATIONS

- LED Drivers

## TYPICAL APPILICATION

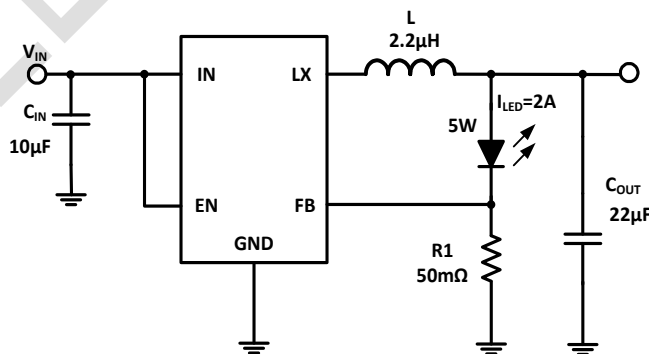
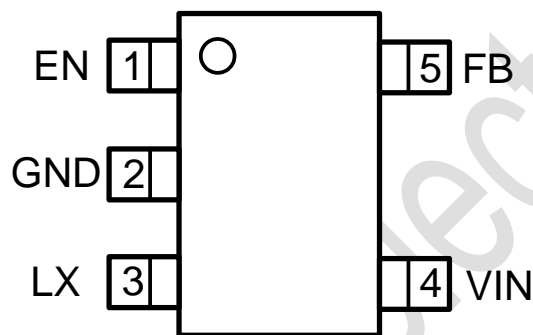

Figure 1. Typical Application Circuits

## ABSOLUTE MAXIMUM RATINGS (Note 1)

Parameter	Value	Unit
Input Supply Voltages	-0.3~6.5	V
LX Voltages	-0.3~6.5	V
EN, FB Voltage	-0.3~6.5	V
Storage Temperature Range	-65~150	°C
Junction Temperature <small>(Note 2)</small>	-40~150	°C
Power Dissipation	600	mW
Lead Temperature Soldering, 10sec	260	°C

## PIN CONFIGURATION



SOT23-5

Top Mark: TL2XXX (TL2: Device Code, XXX: Inside Code)

Part Number	Package	Top mark	Quantity/ Reel
TMI5102	SOT23-5	TL2XXX	3000

TMI5102 devices are Pb-free and RoHS compliant.

**PIN FUNCTIONS**

Pin	Name	Function
1	EN	Chip Enable Pin. Drive EN above 1.5V to turn on the part. Drive EN below 0.4V to turn it off. Do not leave EN floating.
2	GND	Ground Pin
3	LX	Power Switch Output. It is the switch node connection to Inductor.
4	VIN	Power Supply Input. Must be closely decoupled to GND with a 10 $\mu$ F or greater ceramic capacitor.
5	FB	Feedback Pin. A resistor connected between FB to GND is used to program LED current.

**ESD RATING**

Items	Description	Value	Unit
V <sub>ESD</sub>	Human Body Model for all pins	$\pm$ 2000	V

JEDEC specification JS-001

**RECOMMENDED OPERATING CONDITIONS**

Items	Description	Min	Max	Unit
Voltage Range	IN	2.5	5.5	V
T <sub>J</sub>	Operating Junction Temperature Range	-40	125	$^{\circ}$ C

**THERMAL RESISTANCE** (Note 3)

Items	Description	Value	Unit
$\theta_{JA}$	Junction-to-ambient thermal resistance	200	$^{\circ}$ C/W

## ELECTRICAL CHARACTERISTICS

( $V_{IN}=V_{EN}=5$ ,  $T_A = 25^\circ\text{C}$ , unless otherwise noted.)

Parameter	Test Conditions	Min	Typ	Max	Unit
Input Voltage Range		2.5		5.5	V
OVP Threshold			6.0		V
UVLO Threshold			2.3		V
Quiescent Current	$V_{EN}=2.0\text{V}$ , $I_{OUT}=0$ , $V_{FB}=V_{REF} * 105\%$		50	85	$\mu\text{A}$
Shutdown Current	$V_{EN}=0\text{V}$		0.1	1.0	$\mu\text{A}$
Regulated Feedback Voltage	$T_A = 25^\circ\text{C}$		100		mV
Oscillation Frequency	$V_{FB}=100\text{mV}$		1.0		MHz
	$V_{FB}=0\text{V}$		300		kHz
On Resistance of PMOS	$I_{LX}=100\text{mA}$		120		$\text{m}\Omega$
On Resistance of NMOS	$I_{LX}=-100\text{mA}$		70		$\text{m}\Omega$
Peak Current Limit		2.5			A
EN Input Low Level Voltage				0.4	V
EN Input High Level Voltage		1.5			V
EN Leakage Current			$\pm 0.01$	$\pm 1.0$	$\mu\text{A}$
LX Leakage Current	$V_{EN}=0\text{V}$ , $V_{IN}=V_{LX}=5\text{V}$		$\pm 0.01$	$\pm 1.0$	$\mu\text{A}$
Thermal Shutdown Threshold (Note 4)			155		$^\circ\text{C}$
Thermal Shutdown Hysteresis (Note 4)			20		$^\circ\text{C}$

**Note 1:** Absolute Maximum Ratings are those values beyond which the life of a device may be impaired.

**Note 2:**  $T_J$  is calculated from the ambient temperature  $T_A$  and power dissipation  $P_D$  according to the following formula:  $T_J = T_A + (P_D) \times \theta_{JA}$ .

**Note 3:** Measured on JESD51-7, 4-layer PCB.

**Note 4:** Thermal shutdown threshold and hysteresis are guaranteed by design.

## FUNCTION DESCRIPTION

The TMI5102 is a high performance 2.0A, 1.0MHz monolithic step-down LED driver. The TMI5102 requires only three external power components ( $C_{in}$ ,  $C_{out}$  and L). The LED driver current can be programmed with external feedback resistance between FB and GND pin up to 2.0A.

At dropout, the converter duty cycle increases to 100% and the output voltage tracks the input voltage minus the  $R_{DS(ON)}$  drop of the high-side MOSFET.

The internal error amplifier and compensation provides excellent load, and line regulation. The device also integrates many protection features such as input OVP, cycle-by-cycle current limit, over temperature protection.

## FUNCTIONAL BLOCK DIAGRAM

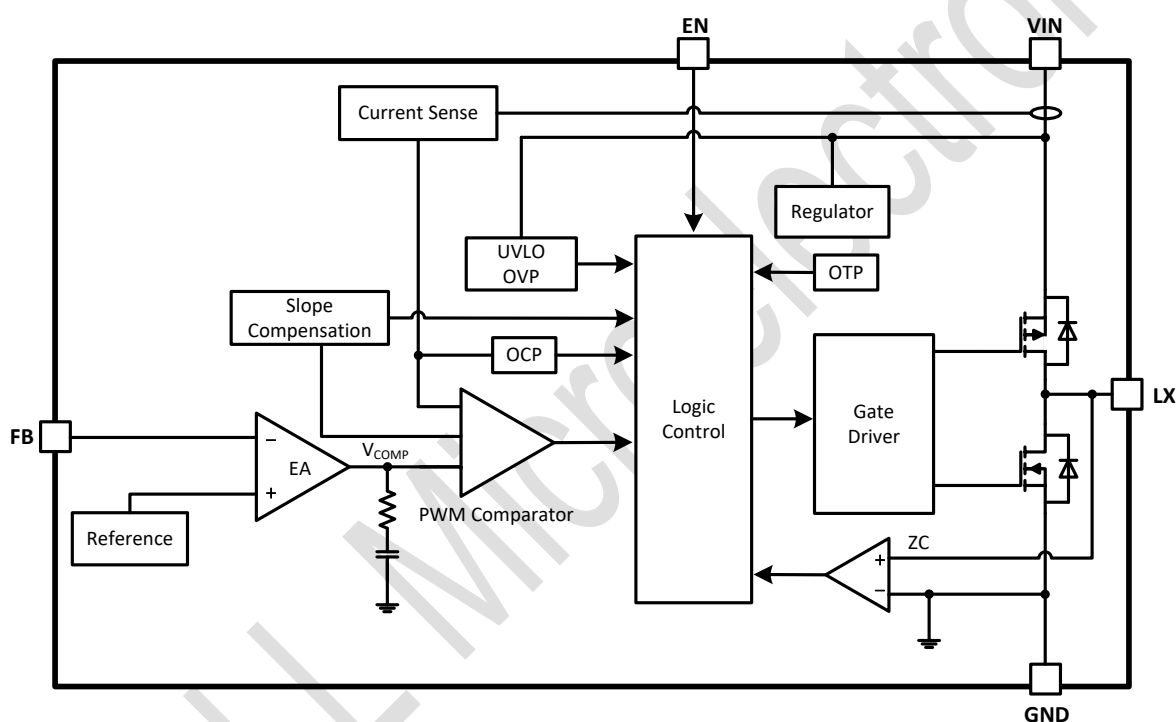

Figure 2. TMI5102 Block Diagram

## APPLICATION INFORMATION

### Setting the Output Voltage

Figure 1 shows the basic application circuit for the TMI5102. LED drive current of the TMI5102 can be externally programmed by resistor R1. The external resistor sets the LED current according to the following equation:

$$I_{LED} = \frac{V_{FB}}{R1}$$

### Inductor Selection

For most designs, 2.2μH inductance can satisfy most application conditions. Inductance value is related to inductor ripple current value, input voltage, output voltage and switching frequency. The inductor value can be derived from the following equation:

$$L = \frac{V_{OUT} \times (V_{IN} - V_{OUT})}{V_{IN} \times \Delta I_L \times f_{OSC}}$$

Where  $\Delta I_L$  is inductor ripple current. Large value inductors result in lower ripple current and small value inductors result in high ripple current, so inductor value has effect on output voltage ripple value. DC resistance of inductor which has impact on efficiency of DC/DC converter should be taken into account when selecting the inductor.

### Input Capacitor Selection

The input capacitor reduces the surge current drawn from the input and switching noise from the device. The input capacitor impedance at the switching frequency should be less than input source impedance to prevent high frequency switching current passing to the input.

A low ESR input capacitor sized for maximum RMS current must be used. Ceramic capacitors with X5R or X7R dielectrics are highly recommended because of their low ESR and small temperature coefficients.

A 10μF ceramic capacitor for most applications is sufficient. A large value may be used for improved input voltage filtering.

### Output Capacitor Selection

The output capacitor is required to keep the output voltage ripple small and to ensure regulation loop stability. The output capacitor must have low impedance at the switching frequency. Ceramic capacitors with X5R or X7R dielectrics are recommended due to their low ESR and high ripple current ratings. The output ripple  $V_{OUT}$  is determined by:

$$\Delta V_{OUT} = \frac{V_{OUT} \times (V_{IN} - V_{OUT})}{V_{IN} \times L \times f_{OSC}} \times \left( ESR + \frac{1}{8 \times f_{OSC} \times C_{OUT}} \right)$$

A 10μF ceramic can satisfy most applications.

### Layout Consideration

When laying out the printed circuit board, the Following checking should be used to ensure proper operation of the TMI5102. Check the following in your layout:

1. The power traces, consisting of the GND trace, the LX trace and the VIN trace should be kept short, direct and wide.
2. Does the (+) plates of Cin connect to Vin as closely as possible. This capacitor provides the AC current to the internal power MOSFETs.
3. Keep the switching node, LX, away from the sensitive VOUT node.
4. Keep the (-) plates of Cin and Cout as close as possible

TOLL Microelectronic

## PACKAGE INFORMATION

### SOT23-5

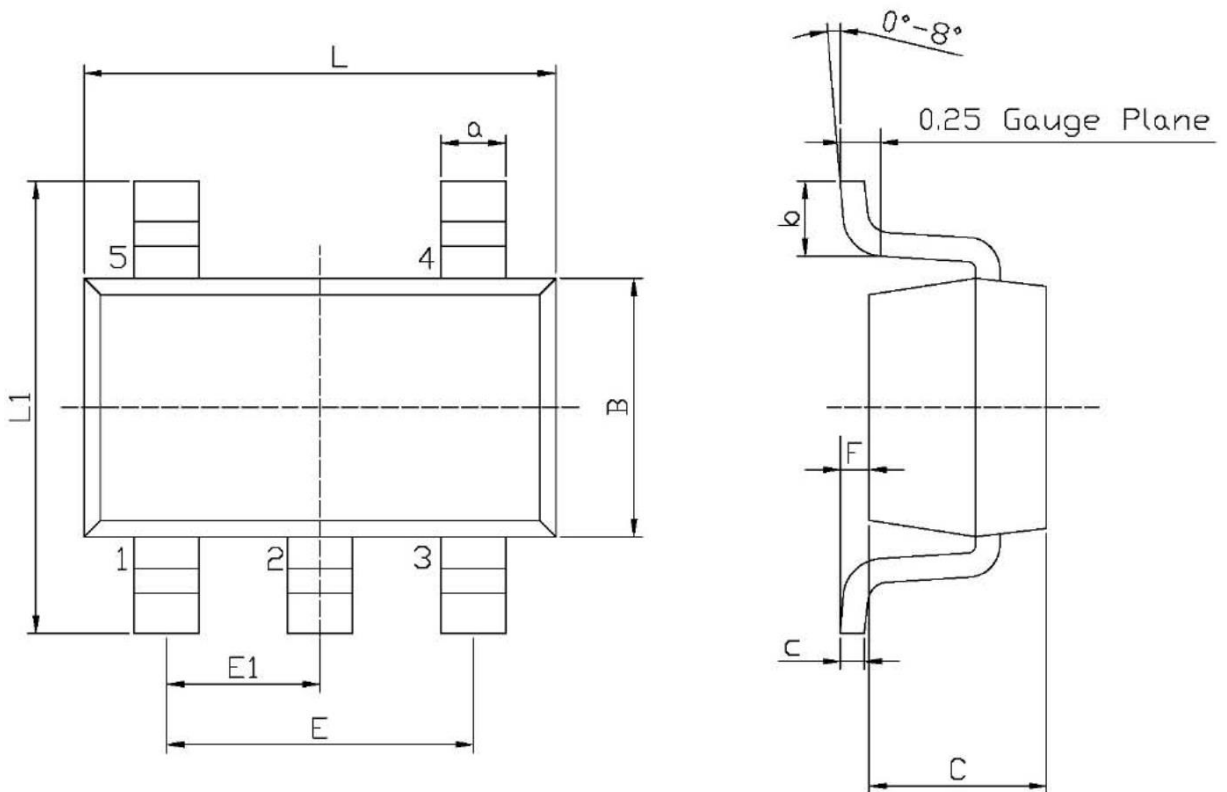

Unit: mm

Symbol	Dimensions In Millimeters		Symbol	Dimensions In Millimeters	
	Min	Max		Min	Max
L	2.82	3.02	E1	0.85	1.05
B	1.50	1.70	a	0.35	0.50
C	0.90	1.30	c	0.10	0.20
L1	2.60	3.00	b	0.35	0.55
E	1.80	2.00	F	0	0.15

**Note:**

- 1) All dimensions are in millimeters.
- 2) Package length does not include mold flash, protrusion or gate burr.
- 3) Package width does not include inter lead flash or protrusion.
- 4) Lead popularity (bottom of leads after forming) shall be 0.10 millimeters max.
- 5) Pin 1 is lower left pin when reading top mark from left to right.



**TAPE AND REEL INFORMATION**

**TAPE DIMENSIONS:**

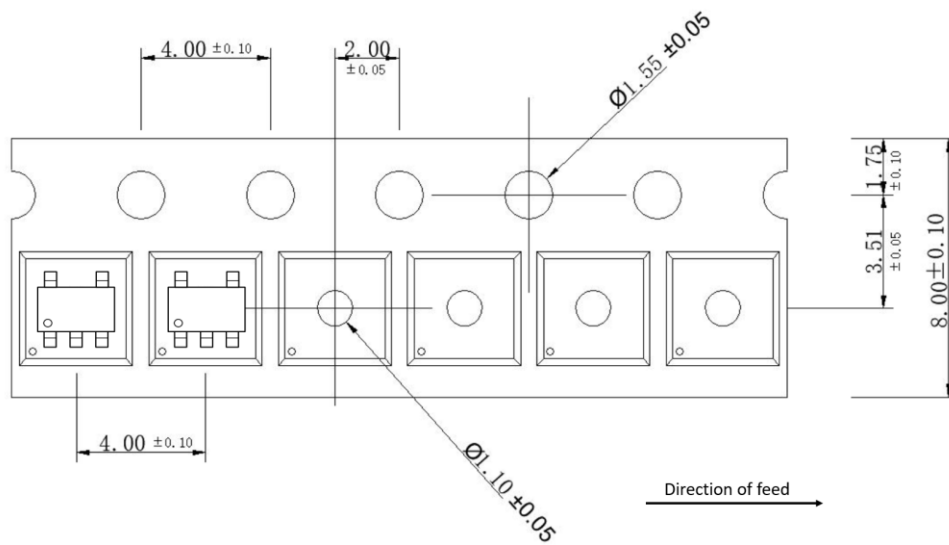

**REEL DIMENSIONS:**

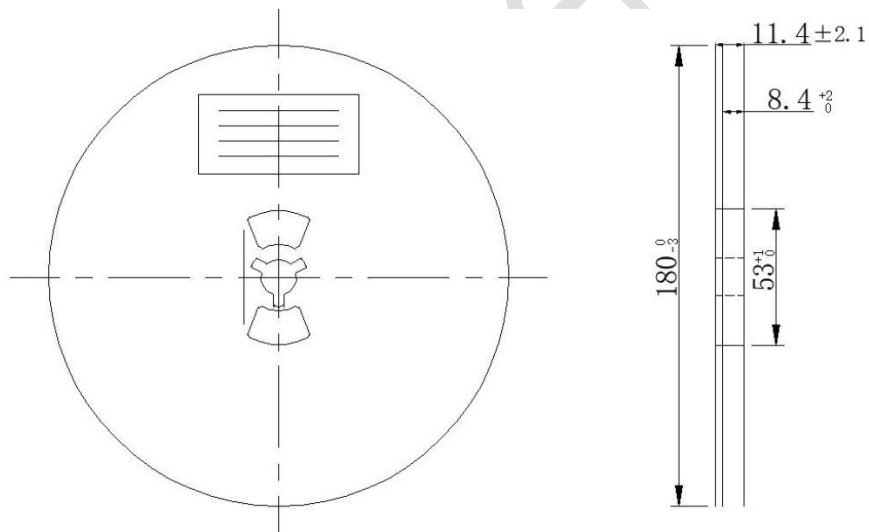

**Note:**

- 1) All Dimensions are in Millimeter
- 2) Quantity of Units per Reel is 3000
- 3) MSL level is level 3.