

# SS32 THUR SS320

## SS32 THUR SS320 Schottky Barrier Rectifiers

### General description

3.0Amp Surface Mounted Schottky Barrier Rectifiers

### FEATURES

- Flammability Classification 94V-O
- For surface mounted applications
- Low profile package
- Built-in strain relief
- Metal to silicon rectifier. majority carrier conduction
- Low power loss,high efficiency
- High surge capacity
- For use in low voltage high frequency inverters, free wheeling, and polarity protection applications
- Pb free product are available : 99% Sn can meet Rohs environment substance directive request

### MECHANICAL DATA

- Terminals:Solder plated, solderable per MIL-STD-750, Method 2026
- Polarity: Color band denotes positive end (cathode)
- Weight: 0.002 ounce, 0.060 gram

### PINNING

PIN	DESCRIPTION
1	Cathode
2	Anode

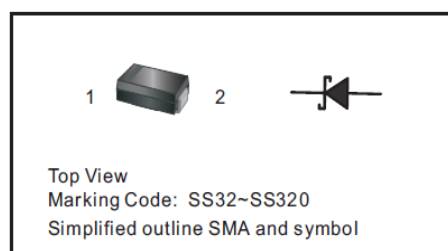

### Maximum Ratings And Electrical Characteristics

Parameter	Symbols	SS32	SS34	SS34A	SS36	SS38	SS310	SS312	SS315	SS320	Units
Maximum Repetitive Peak Reverse Voltage	$V_{RRM}$	20	40	45	60	80	100	120	150	200	V
Maximum RMS voltage	$V_{RMS}$	14	28	31.5	42	56	70	84	105	140	V
Maximum DC Blocking Voltage	$V_{DC}$	20	40	45	60	80	100	120	150	200	V
Maximum Average Forward Rectified Current	$I_{F(AV)}$	3.0									A
Peak Forward Surge Current,8.3ms Single Half Sine-wave Superimposed on Rated Load (JEDEC method)	$I_{FSM}$	80									A
Max Instantaneous Forward Voltage at 3 A	$V_F$	0.55	0.70			0.85		0.95			V
Maximum DC Reverse Current $T_a = 25^\circ\text{C}$ at Rated DC Reverse Voltage $T_a = 100^\circ\text{C}$	$I_R$	0.5			0.3		3				mA
Typical Junction Capacitance <sup>(1)</sup>	$C_j$	450			400						pF
Typical Thermal Resistance <sup>(2)</sup>	$R_{\theta JA}$	70									$^\circ\text{C/W}$
Operating Junction Temperature Range	$T_j$	-55 ~ +150									$^\circ\text{C}$
Storage Temperature Range	$T_{stg}$	-55 ~ +150									$^\circ\text{C}$

(1) Measured at 1 MHz and applied reverse voltage of 4 V D.C

(2) P.C.B. mounted with 2.0" X 2.0" (5 X 5 cm) copper pad areas.

## Rating And Characteristic Curves

Fig.1 Forward Current Derating Curve

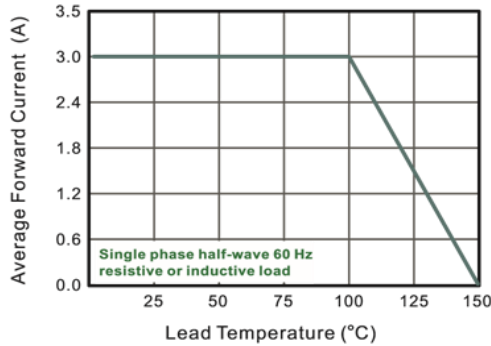

Fig.2 Typical Reverse Characteristics

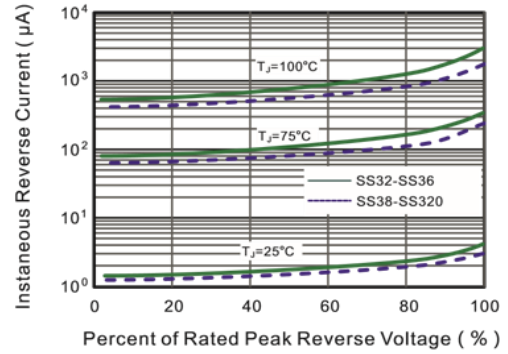

Fig.3 Typical Forward Characteristic

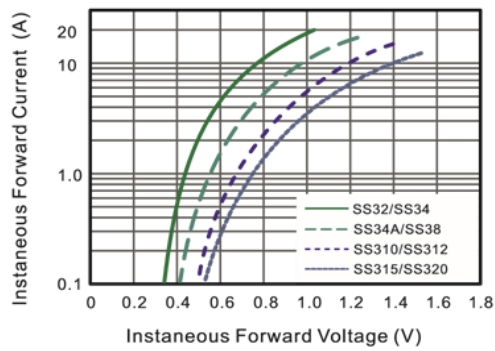

Fig.4 Typical Junction Capacitance

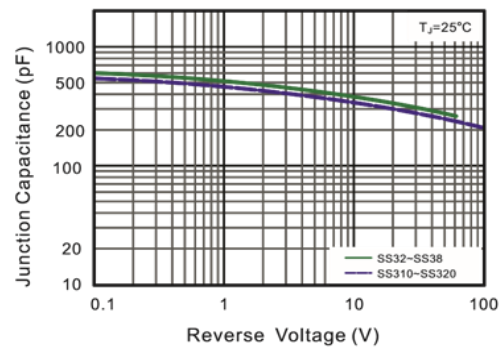

Fig.5 Maximum Non-Repetitive Peak Forward Surge Current

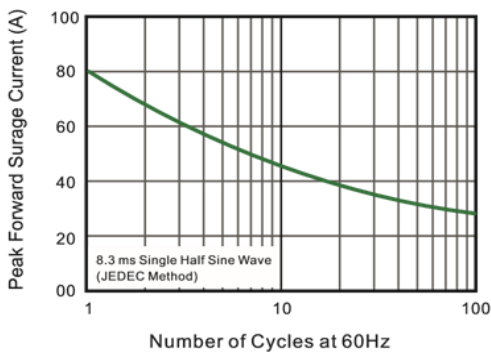
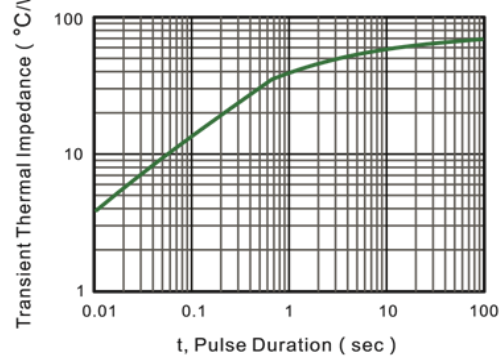

Fig.5- Typical Transient Thermal Impedance



# SS32 THUR SS320

## PACKAGE OUTLINE

Plastic surface mounted package; 2 leads

SMA

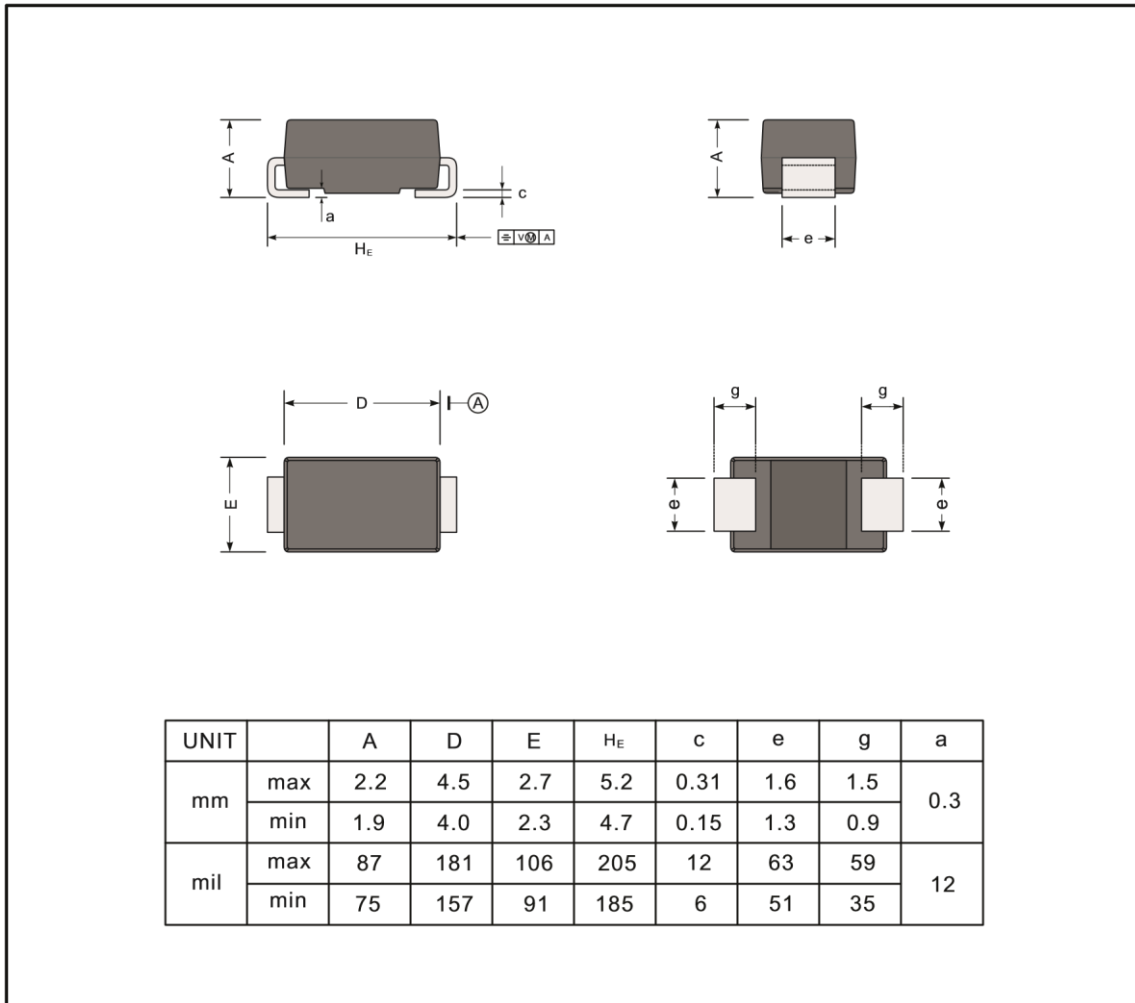

### The recommended mounting pad size

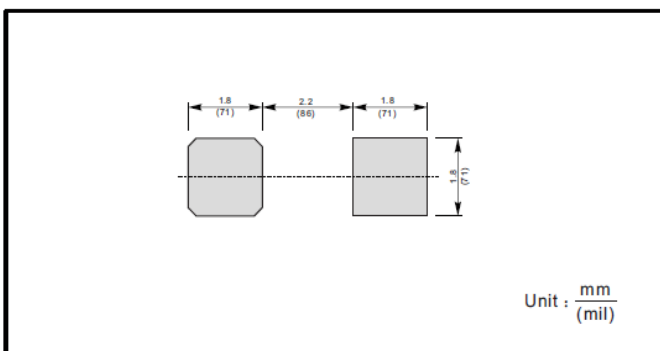

### Marking

Type number	Marking code
SS32	SS32
SS34	SS34
SS34A	SS34A
SS36	SS36
SS38	SS38
SS310	SS310
SS312	SS312
SS315	SS315
SS320	SS320

## **Important Notice and Disclaimer**

DOESHARE has used reasonable care in preparing the information included in this document, but DOESHARE does not warrant that such information is error free. DOESHARE assumes no liability whatsoever for any damages incurred by you resulting from errors in or omissions from the information included herein.

DOESHARE no warranty, representation or guarantee regarding the documents, circuits and products specification, DOESHARE reservation rights to make changes for any documents, products, circuits and specifications at any time without notice.

Purchasers are solely responsible for the choice, selection and use of the DOESHARE products and services described herein, and DOESHARE assumes no liability whatsoever relating to the choice, selection or use of the products and services described herein.

No license, express or implied, by implication or otherwise under any intellectual property rights of DOESHARE.

Resale of DOESHARE products with provisions different from the statements and/or technical features set forth in this document shall immediately void any warranty granted by DOESHARE for the DOESHARE product or service described herein and shall not create or extend in any manner whatsoever, any liability of DOESHARE.