

FH8205A
N-Channel Enhancement Mode

General Description	Product Summary								
FH8205A uses advanced trench technology to provide excellent $R_{DS(ON)}$, low gate charge and operation with gate voltages as low as 2.5V. This device is suitable for use as a Battery protection or in other Switching application.	<table> <tr> <td>V_{DS}</td> <td>20 V</td> </tr> <tr> <td>I_D (at $V_{GS}=4.5V$)</td> <td>5.0A</td> </tr> <tr> <td>$R_{DS(ON)}$ (at $V_{GS} = 4.5V$)</td> <td>< 27mΩ</td> </tr> <tr> <td>$R_{DS(ON)}$ (at $V_{GS} = 2.5V$)</td> <td>< 32mΩ</td> </tr> </table>	V_{DS}	20 V	I_D (at $V_{GS}=4.5V$)	5.0A	$R_{DS(ON)}$ (at $V_{GS} = 4.5V$)	< 27m Ω	$R_{DS(ON)}$ (at $V_{GS} = 2.5V$)	< 32m Ω
V_{DS}	20 V								
I_D (at $V_{GS}=4.5V$)	5.0A								
$R_{DS(ON)}$ (at $V_{GS} = 4.5V$)	< 27m Ω								
$R_{DS(ON)}$ (at $V_{GS} = 2.5V$)	< 32m Ω								

TSSOP-8

Schematic diagram

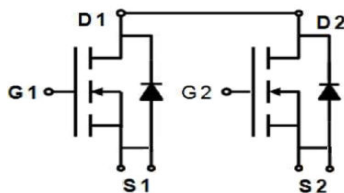
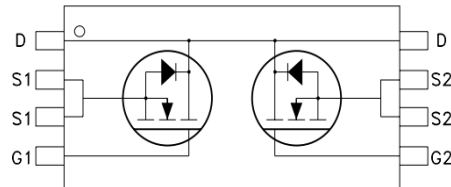

Marking and pin Assignment

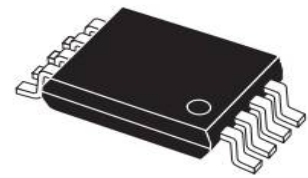

TSSOP-8 top view

Absolute Maximum Ratings $T_A=25^{\circ}C$ unless otherwise noted

Parameter	Symbol	Limit	Unit
Drain-Source Voltage	V_{DS}	20	V
Gate-Source Voltage	V_{GS}	± 12	V
Drain Current-Continuous @ $T_J=25^{\circ}C$	I_D	5	A
Pulsed ^b	I_{DM}	20	A
Drain-Source Diode Forward Current ^a	I_S	2.5	A
Maximum Power Dissipation ^a	P_D	1.25	W
Operating Junction and Storage Temperature Range	T_J, T_{STG}	-55 To 150	$^{\circ}C$

Thermal Characteristic

Parameter	Symbol	Limit	Unit
Thermal Resistance, Junction-to-Ambient ^a	$R_{\theta JA}$	100	$^{\circ}C/W$

Electrical Characteristics (TA=25°C unless otherwise noted)

Parameter	Symbol	Condition	Min	Typ ^c	Max	Unit
Off Characteristics						
Drain-Source Breakdown Voltage	BV _{DSS}	V _{GS} =0V I _D =250μA	20	-	-	V
Zero Gate Voltage Drain Current	I _{DSS}	V _{DS} =20V, V _{GS} =0V	-	-	1	μA
Gate-Body Leakage Current	I _{GSS}	V _{GS} =±12V, V _{DS} =0V	-	-	±100	nA
On Characteristics						
Gate Threshold Voltage	V _{GS(th)}	V _{DS} =V _{GS} , I _D =250μA	0.5	0.7	1.2	V
Drain-Source On-State Resistance	R _{DS(ON)}	V _{GS} =4.5V, I _D =4.5A	-	20	27	mΩ
		V _{GS} =2.5V, I _D =3.5A	-	26	32	mΩ
Forward Transconductance	g _{FS}	V _{DS} =5V, I _D =7A	-	17.7	-	S
Dynamic Characteristics						
Input Capacitance	C _{iss}	V _{DS} =8V, V _{GS} =0V, F=1.0MHz	-	802	-	pF
Output Capacitance	C _{oss}		-	153	-	pF
Reverse Transfer Capacitance	C _{rss}		-	122	-	pF
Switching Characteristics						
Turn-on Delay Time	t _{d(on)}	V _{DD} =10V, I _D =1A V _{GS} =4.5V, R _{GEN} =10Ω, R _L =10Ω	-	18	-	nS
Turn-on Rise Time	t _r		-	5	-	nS
Turn-Off Delay Time	t _{d(off)}		-	43.8	-	nS
Turn-Off Fall Time	t _f		-	20	-	nS
Total Gate Charge	Q _g	V _{DS} =10V, I _D =4A, V _{GS} =4.5V	-	10.5	-	nC
Gate-Source Charge	Q _{gs}		-	2	-	nC
Gate-Drain Charge	Q _{gd}		-	2.5	-	nC
Drain-Source Diode Characteristics						
Diode Forward Voltage	V _{SD}	V _{GS} =0V, I _S =1.7A	-	-	1.2	V

Notes:

- Surface Mounted on FR4 Board ,T<10 sec ;
- Pulse Test: Pulse Width ≤ 300 μ s, Duty Cycle ≤ 2%.
- Guaranteed by Design, not subject to production testing.

TYPICAL ELECTRICAL AND THERMAL CHARACTERISTICS

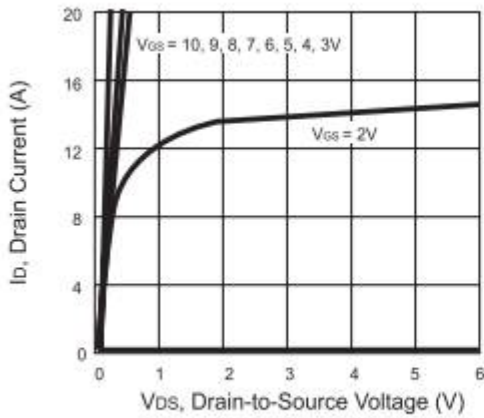

Figure 1. Output Characteristics

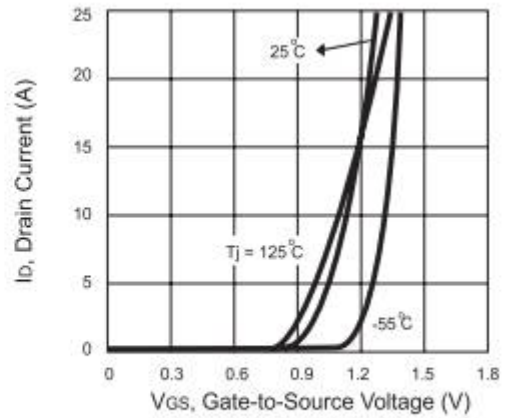

Figure 2. Transfer Characteristics

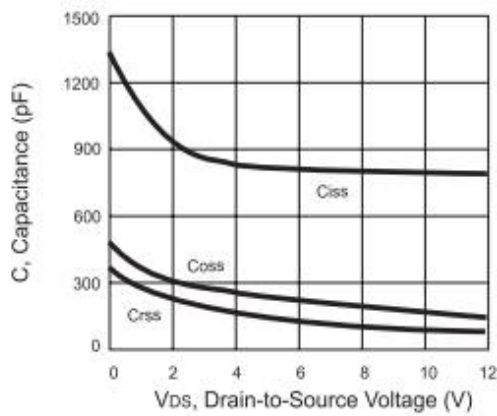

Figure 3. Capacitance

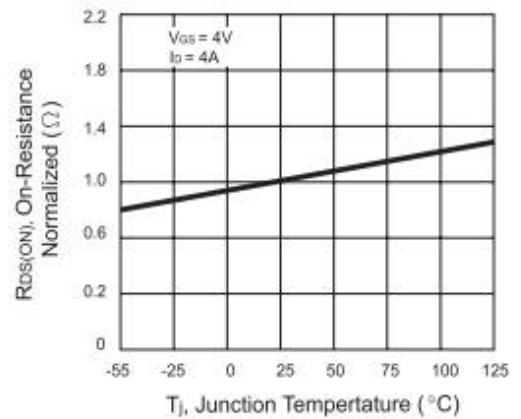

Figure 4. On-Resistance Variation with Temperature

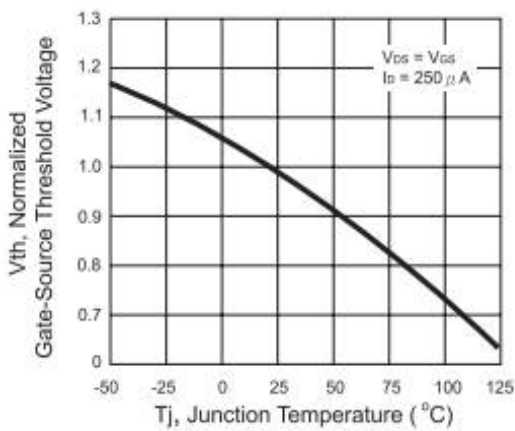

Figure 5. Gate Threshold Variation with Temperature

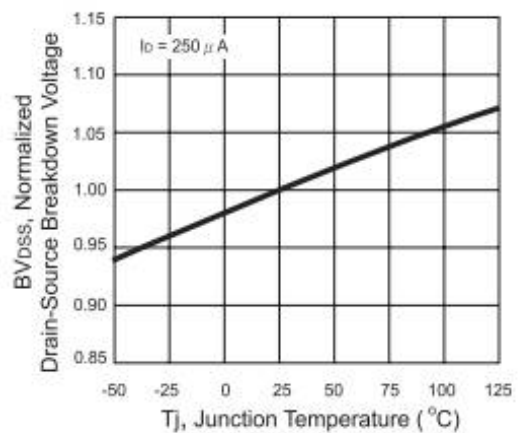

Figure 6. Breakdown Voltage Variation with Temperature

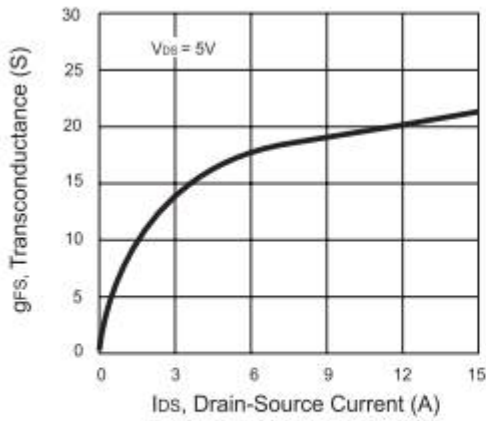

Figure 7. Transconductance Variation with Drain Current

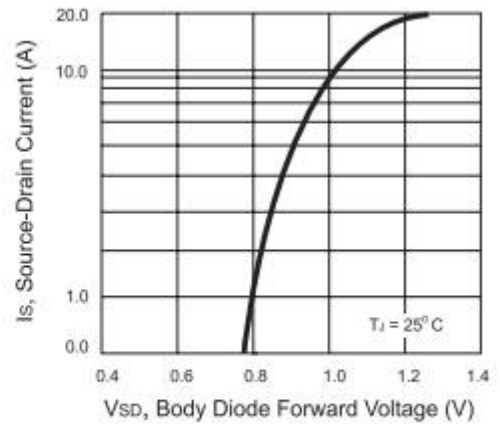

Figure 8. Body Diode Forward Voltage Variation with Source Current

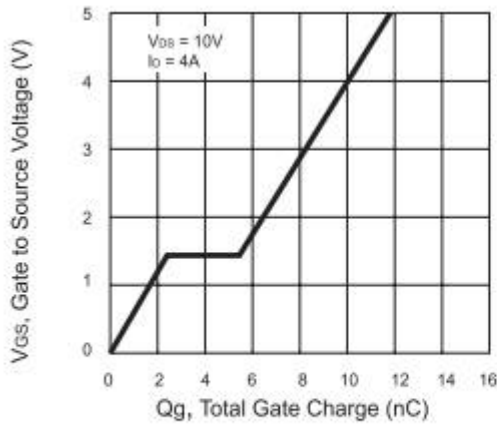

Figure 9. Gate Charge

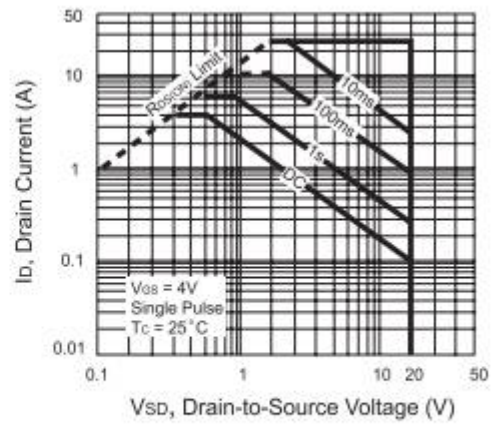

Figure 10. Maximum Safe Operating Area

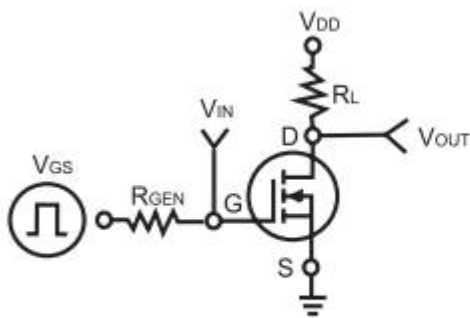

Figure 11. Switching Test Circuit

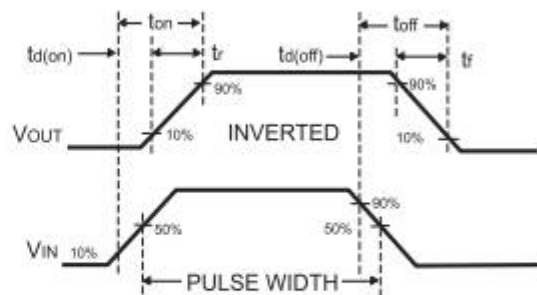

Figure 12. Switching Waveforms

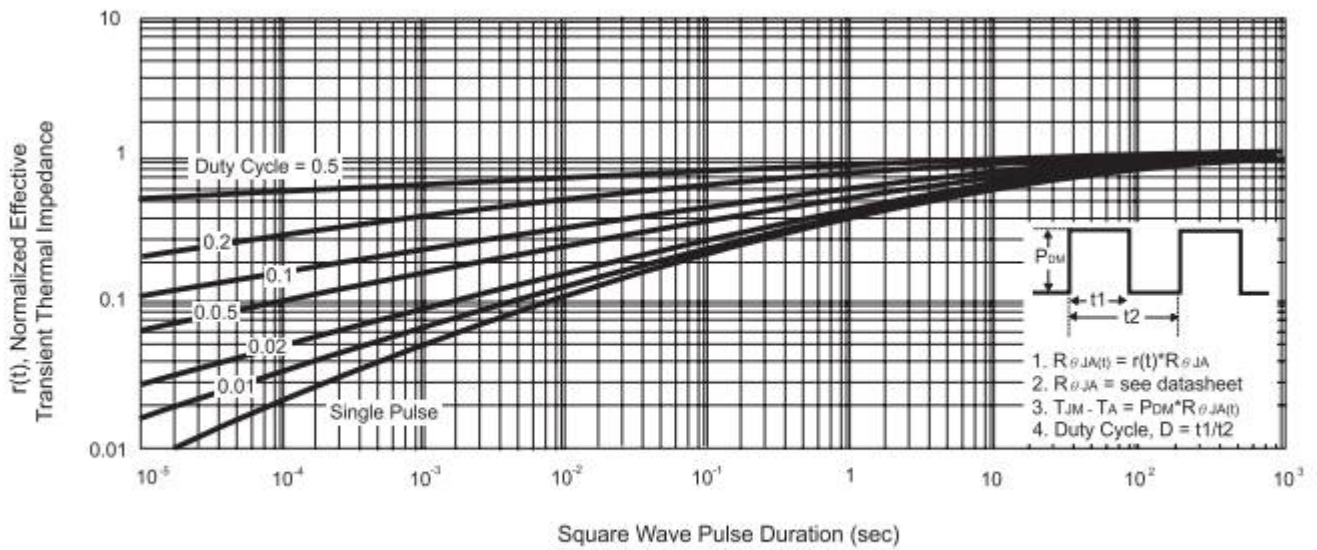

Figure 13. Normalized Thermal Transient Impedance Curve

MARKING DESCRIPTION

TSSOP-8



NOTE:

- AAAA : Internal Code
- BB : Year Code
- CC : Week Code
- DD : Serial Code

Package Outline Dimensions

TSSOP-8

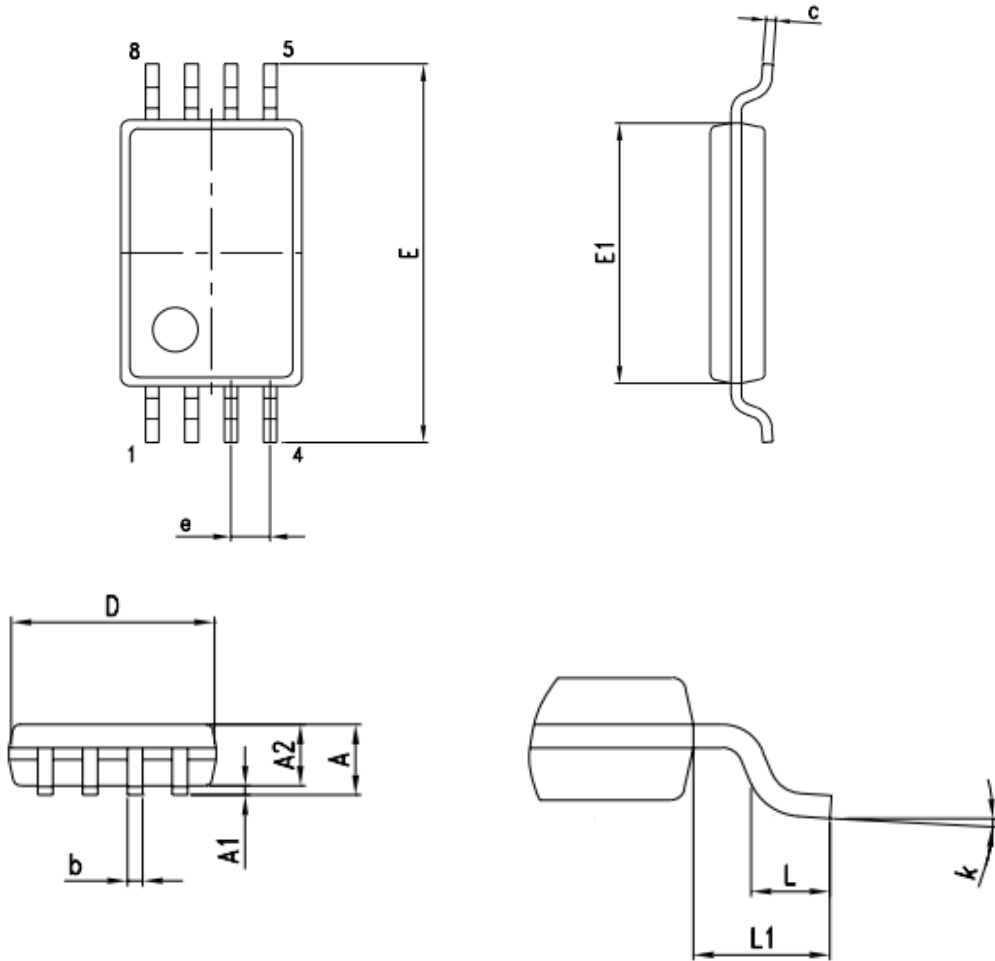

DIM.	mm.			inch.		
	MIN.	TYP.	MAX.	MIN.	TYP.	MAX.
A	1.05		1.20	0.041		0.047
A1	0.05		0.15	0.002		0.006
A2	0.80		1.05	0.032		0.041
b	0.19		0.30	0.008		0.012
c	0.090		0.20	0.003		0.007
D	2.90		3.10	0.114		0.122
E	6.20		6.60	0.240		0.260
E1	4.30		4.50	0.170		0.177
e		0.65			0.025	
L	0.45		0.75	0.018		0.030
L1		1.00			0.039	
k	0°		8°	0.192		0.208