

低噪声和低失真通用 **FET** 输入音频运算放大器

1 说明

HT1652A (双通道) 和 HT1654A (四通道) FET 输入运算放大器在 1kHz 时可实现 $7.5\text{nV}/\sqrt{\text{Hz}}$ 的低噪声密度和 0.0005% 的超低失真。HT1652A 和 HT1654A 运算放大器在 $2\text{k}\Omega$ 负载条件下提供摆幅在 800mV 这有助于提高余量并实现动态范围的最大化。此外, 这些器件还具有 $\pm 50\text{mA}$ 高输出驱动能力。

2 特性

- 低噪声:
 - $7.5\text{nV}/\sqrt{\text{Hz}}$ (频率为 1kHz 时)
 - $5.8\text{nV}/\sqrt{\text{Hz}}$ (频率为 10kHz 时)
- 低失真: 1kHz 时为 0.0005%
- 低静态电流:
 - 每通道 6mA
- 低输入偏压电流: 5nA
- 压摆率: $6\text{V}/\mu\text{s}$
- 宽增益带宽: 15MHz ($G = 1$)
- 单位增益稳定
- 宽电源电压范围:
 - $\pm 2.25\text{V}$ 至 $\pm 18\text{V}$ 或 4.5V 至 36V
- 可提供双通道和四通道版本

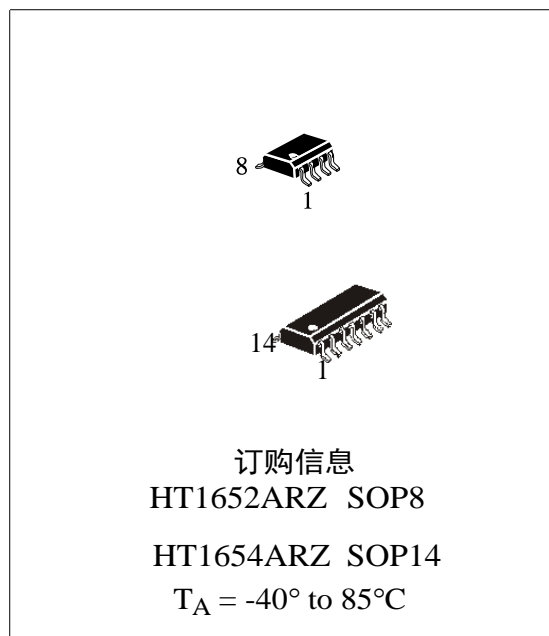

3 应用

- 模拟和数字混音器
- 音效处理器
- 乐器
- A/V 接收器
- DVD 和蓝光(Blu-Ray)TM播放器
- 车载音频系统

输入电压噪声频谱密度

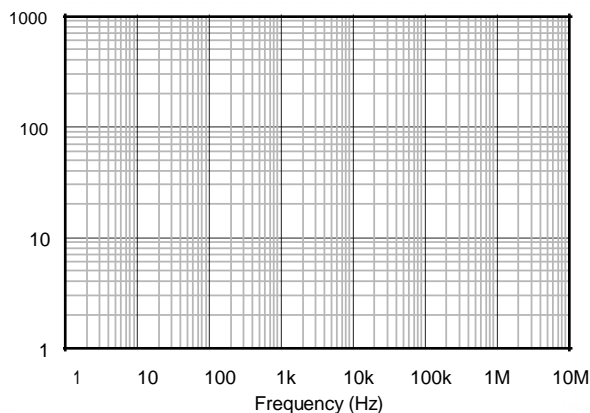

5 Pin Configuration and Functions

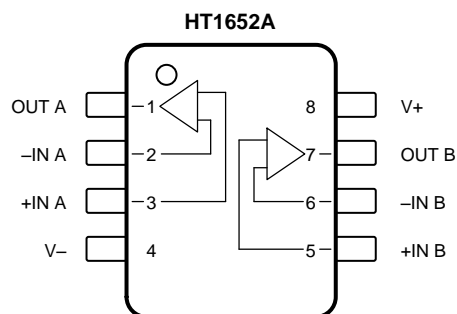

Pin Functions: HT1652A

| PIN | | I/O | DESCRIPTION |
|-------------|-----|-----|--|
| NAME | NO. | | |
| -IN A | 2 | I | Inverting input, channel A |
| +IN A | 3 | I | Noninverting input, channel A |
| -IN B | 6 | I | Inverting input, channel B |
| +IN B | 5 | I | Noninverting input, channel B |
| OUT A | 1 | O | Output, channel A |
| OUT B | 7 | O | Output, channel B |
| V- | 4 | — | Negative (lowest) power supply |
| V+ | 8 | — | Positive (highest) power supply |
| Thermal pad | — | — | Exposed thermal die pad on underside of DRG package; connect thermal die pad to V-. Soldering the thermal pad improves heat dissipation and provides specified performance |

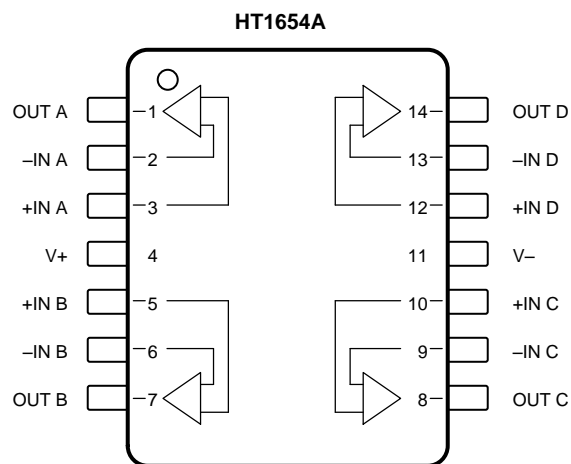

Pin Functions: HT1654A

| PIN | | I/O | DESCRIPTION |
|-------|-----|-----|---------------------------------|
| NAME | NO. | | |
| -IN A | 2 | I | Inverting input, channel A |
| +IN A | 3 | I | Noninverting input, channel A |
| -IN B | 6 | I | Inverting input, channel B |
| +IN B | 5 | I | Noninverting input, channel B |
| -IN C | 9 | I | Inverting input, channel C |
| +IN D | 10 | I | Noninverting input, channel C |
| -IN D | 13 | I | Inverting input, channel D |
| +IN D | 12 | I | Noninverting input, channel D |
| OUT A | 1 | O | Output, channel A |
| OUT B | 7 | O | Output, channel B |
| OUT C | 8 | O | Output, channel C |
| OUT D | 14 | O | Output, channel D |
| V- | 11 | — | Negative (lowest) power supply |
| V+ | 4 | — | Positive (highest) power supply |

6.1 Absolute Maximum Ratings

over operating free-air temperature range (unless otherwise noted)⁽¹⁾

| | | MIN | MAX | UNIT |
|-------------|---|--------------|--------------|------|
| Voltage | Supply voltage, $V_S = (V+) - (V-)$ | 40 | | V |
| | Input | $(V-) - 0.5$ | $(V+) + 0.5$ | V |
| Current | Input (all pins except power-supply pins) | -10 | 10 | mA |
| | Output short-circuit ⁽²⁾ | Continuous | | |
| Temperature | Operating, T_A | -55 | 125 | °C |
| | Junction, T_J | 200 | | °C |
| | Storage, T_{stg} | -65 | 150 | °C |

(1) Stresses beyond those listed under *Absolute Maximum Ratings* may cause permanent damage to the device. These are stress ratings only, which do not imply functional operation of the device at these or any other conditions beyond those indicated under *Recommended Operating Conditions*. Exposure to absolute-maximum-rated conditions for extended periods may affect device reliability.

(2) Short-circuit to $V_S / 2$ (ground in symmetrical dual supply setups), one amplifier per package.

6.2 ESD Ratings

| | | VALUE | UNIT |
|-------------------------------------|--|-------|------|
| $V_{(ESD)}$ Electrostatic discharge | Human-body model (HBM), per ANSI/ESDA/JEDEC JS-001 ⁽¹⁾ | ±2000 | V |
| | Charged-device model (CDM), per JEDEC specification JESD22-C101 ⁽²⁾ | ±1000 | |
| | Machine model (MM) | ±200 | |

(1) JEDEC document JEP155 states that 500-V HBM allows safe manufacturing with a standard ESD control process.

(2) JEDEC document JEP157 states that 250-V CDM allows safe manufacturing with a standard ESD control process.

6.3 Recommended Operating Conditions

over operating free-air temperature range (unless otherwise noted)

| | | MIN | NOM | MAX | UNIT |
|-------|-----------------------|-------------|-----|----------|------|
| | Supply voltage | 4.5 (±2.25) | | 36 (±18) | V |
| T_A | Operating temperature | -40 | 85 | | °C |

6.4 Thermal Information: HT1652A

| THERMAL METRIC ⁽¹⁾ | HT1652A | | | UNIT |
|---|----------|-------------|------------|------|
| | D (SOIC) | DGK (VSSOP) | DRG (WSON) | |
| | 8 PINS | 8 PINS | 8 PINS | |
| θ_{JA} Junction-to-ambient thermal resistance | 143.6 | 218.9 | 66.9 | °C/W |
| $\theta_{JC(top)}$ Junction-to-case (top) thermal resistance | 76.9 | 78.6 | 54.5 | °C/W |
| θ_{JB} Junction-to-board thermal resistance | 61.8 | 103.7 | 40.4 | °C/W |
| ψ_{JT} Junction-to-top characterization parameter | 27.8 | 14.6 | 1.9 | °C/W |
| ψ_{JB} Junction-to-board characterization parameter | 61.3 | 101.8 | 40.4 | °C/W |
| $\theta_{JC(bot)}$ Junction-to-case (bottom) thermal resistance | N/A | N/A | 10.8 | °C/W |

- (1) For more information about traditional and new thermal metrics, see the [Semiconductor and IC Package Thermal Metrics](#) application report.

6.5 Thermal Information: HT1654A

| THERMAL METRIC ⁽¹⁾ | HT1654A | | UNIT |
|---|----------|------------|------|
| | D (SOIC) | PW (TSSOP) | |
| | 14 PINS | 14 PINS | |
| θ_{JA} Junction-to-ambient thermal resistance | 90.1 | 126.9 | °C/W |
| $\theta_{JC(top)}$ Junction-to-case (top) thermal resistance | 54.8 | 46.6 | °C/W |
| θ_{JB} Junction-to-board thermal resistance | 44.4 | 58.6 | °C/W |
| ψ_{JT} Junction-to-top characterization parameter | 19.9 | 5.5 | °C/W |
| ψ_{JB} Junction-to-board characterization parameter | 44.2 | 57.8 | °C/W |
| $\theta_{JC(bot)}$ Junction-to-case (bottom) thermal resistance | N/A | N/A | °C/W |

- (1) For more information about traditional and new thermal metrics, see the [Semiconductor and IC Package Thermal Metrics](#) application report.

6.6 Electrical Characteristics: $V_S = \pm 15\text{ V}$

 at $T_A = 25^\circ\text{C}$, $R_L = 2\text{ k}\Omega$, and $V_{CM} = V_{OUT} = \text{midsupply}$, unless otherwise noted

| PARAMETER | | TEST CONDITIONS | MIN | TYP | MAX | UNIT |
|----------------------------|--------------------------------------|---|---|-----------|---------------|------------------------------|
| FREQUENCY RESPONSE | | | | | | |
| GBW | Gain-bandwidth product | $G = 1$ | | 15 | | MHz |
| SR | Slew rate | $G = -1$ | | 10 | | V/ μs |
| | Full power bandwidth ⁽¹⁾ | $V_O = 1\text{ V}_P$ | | 1.6 | | MHz |
| | Overload recovery time | $G = -10$ | | 1 | | μs |
| | Channel separation (dual and quad) | $f = 1\text{ kHz}$ | | -120 | | dB |
| NOISE | | | | | | |
| e_n | Input voltage noise | $f = 20\text{ Hz to } 20\text{ kHz}$ | | 4.0 | | μV_{PP} |
| | Input voltage noise density | $f = 1\text{ kHz}$ | | 7.5 | | nV/ $\sqrt{\text{Hz}}$ |
| | | $f = 10\text{ kHz}$ | | 5.8 | | nV/ $\sqrt{\text{Hz}}$ |
| i_n | Input current noise density | $f = 1\text{ kHz}$ | | 3 | | fA/ $\sqrt{\text{Hz}}$ |
| OFFSET VOLTAGE | | | | | | |
| V_{OS} | Input offset voltage | $V_S = \pm 2.25\text{ V to } \pm 18\text{ V}$ | | ± 0.5 | ± 1.5 | mV |
| | | $V_S = \pm 2.25\text{ V to } \pm 18\text{ V}, T_A = -40^\circ\text{C to } 85^\circ\text{C}^{(2)}$ | | 2 | 8 | $\mu\text{V}/^\circ\text{C}$ |
| PSRR | Power-supply rejection ratio | $V_S = \pm 2.25\text{ V to } \pm 18\text{ V}$ | | 3 | 8 | $\mu\text{V}/\text{V}$ |
| INPUT BIAS CURRENT | | | | | | |
| I_B | Input bias current | $V_{CM} = 0\text{ V}$ | | ± 10 | ± 100 | pA |
| I_{OS} | Input offset current | $V_{CM} = 0\text{ V}$ | | ± 10 | ± 100 | pA |
| INPUT VOLTAGE RANGE | | | | | | |
| V_{CM} | Common-mode voltage range | | $(V_-) + 0.5$ | | $(V_+) - 2$ | V |
| CMRR | Common-mode rejection ratio | | 100 | 110 | | dB |
| INPUT IMPEDANCE | | | | | | |
| | Differential | | | 100 6 | | M Ω pF |
| | Common-mode | | | 6000 2 | | G Ω pF |
| OPEN-LOOP GAIN | | | | | | |
| A_{OL} | Open-loop voltage gain | $(V_-) + 0.8\text{ V} \leq V_O \leq (V_+) - 0.8\text{ V}, R_L = 2\text{ k}\Omega$ | 106 | 114 | | dB |
| OUTPUT | | | | | | |
| V_{OUT} | Voltage output | $R_L = 2\text{ k}\Omega$ | $(V_-) + 0.8$ | | $(V_+) - 0.8$ | V |
| I_{OUT} | Output current | | See Typical Characteristics | | | mA |
| Z_O | Open-loop output impedance | $f = 1\text{ MHz}$ | See Typical Characteristics | | | Ω |
| I_{SC} | Short-circuit current ⁽³⁾ | | | ± 50 | | mA |
| C_{LOAD} | Capacitive load drive | | | 100 | | pF |
| POWER SUPPLY | | | | | | |
| V_S | Specified voltage | | ± 2.25 | | ± 18 | V |
| I_Q | Quiescent current | $I_{OUT} = 0\text{ A}$ | | 2 | 2.5 | mA |
| | (per channel) | $I_{OUT} = 0\text{ A}, T_A = -40^\circ\text{C to } 85^\circ\text{C}^{(2)}$ | | | 2.8 | mA |
| TEMPERATURE | | | | | | |
| | Specified range | | -40 | | 85 | $^\circ\text{C}$ |
| | Operating range | | -55 | | 125 | $^\circ\text{C}$ |

 (1) Full-power bandwidth = $SR / (2\pi \times V_P)$, where SR = slew rate.

(2) Specified by design and characterization.

(3) One channel at a time.

6.7 Typical Characteristics

at $T_A = 25^\circ\text{C}$, $V_S = \pm 15\text{ V}$, and $R_L = 2\text{ k}\Omega$, unless otherwise noted.



图 1. Input Voltage Noise Density vs Frequency



图 2. 0.1-Hz to 10-Hz Noise

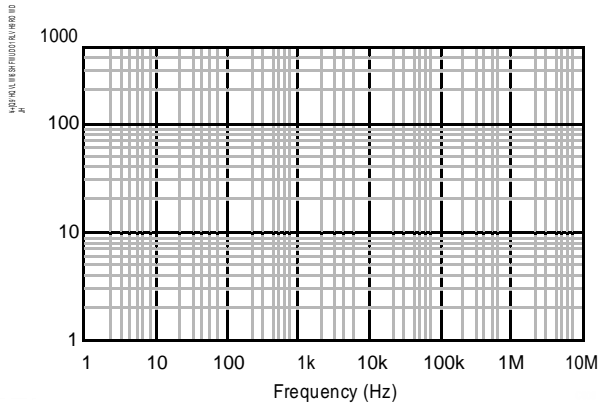

图 3. Voltage Noise vs Source Resistance

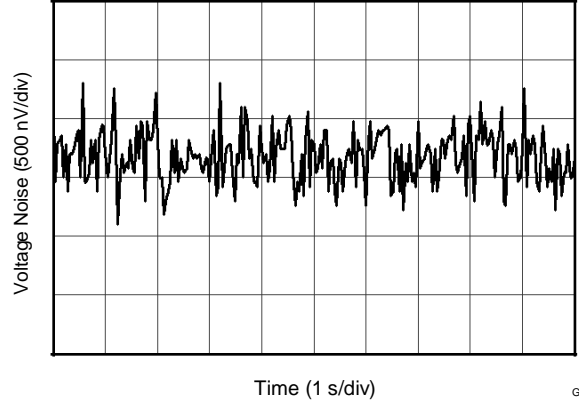

图 4. Maximum Output Voltage vs Frequency

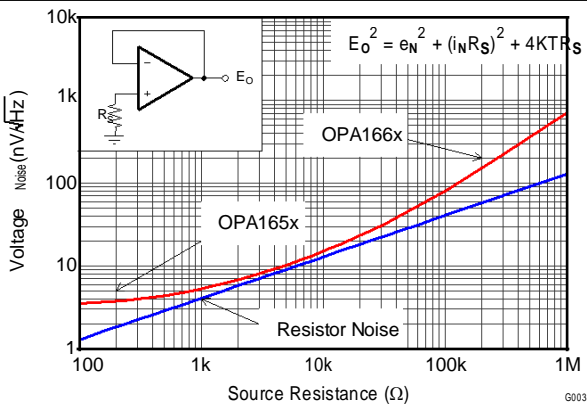

图 5. Gain and Phase vs Frequency

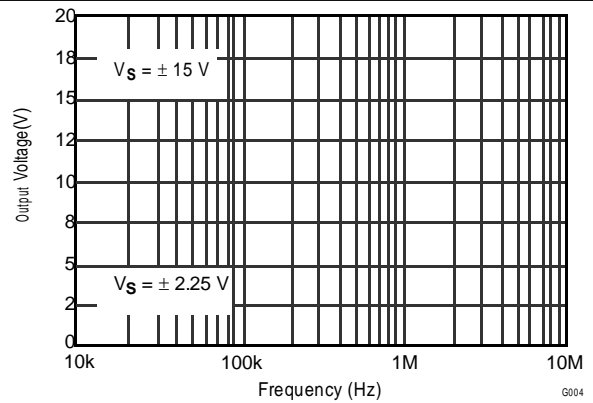

图 6. Closed-Loop Gain vs Frequency

Typical Characteristics (接下页)

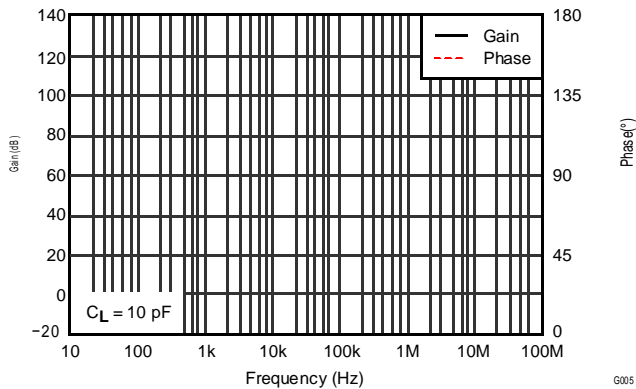
 at $T_A = 25^\circ\text{C}$, $V_S = \pm 15\text{ V}$, and $R_L = 2\text{ k}\Omega$, unless otherwise noted.

图 7. THD+N Ratio vs Frequency

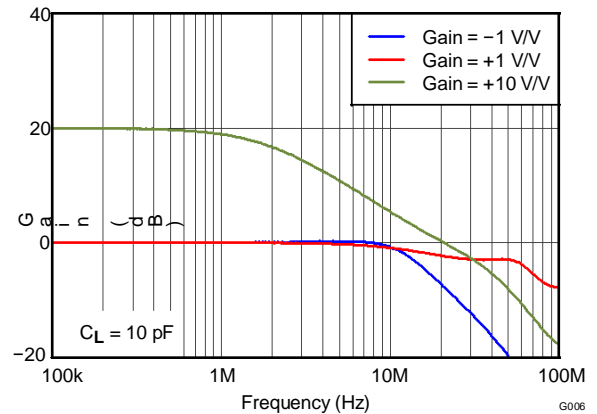
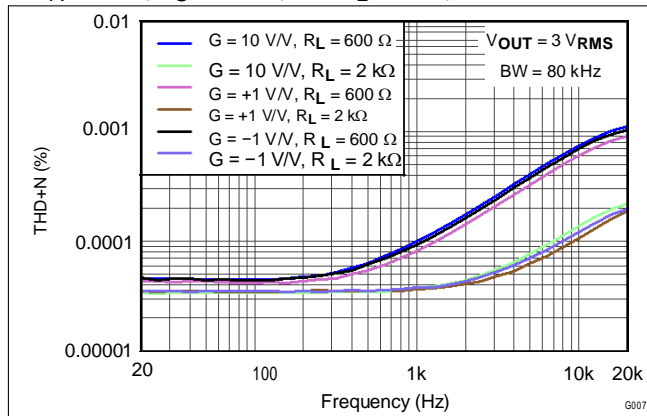
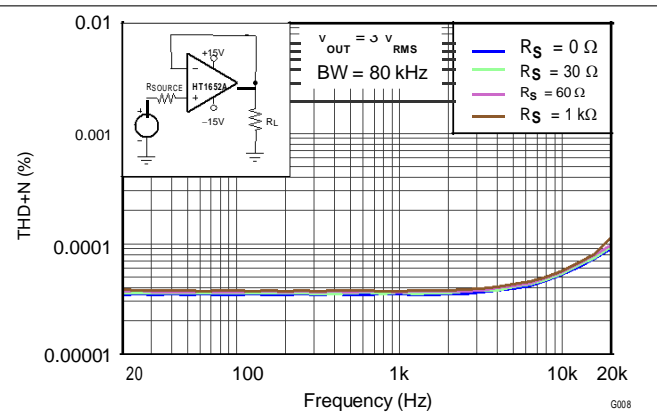
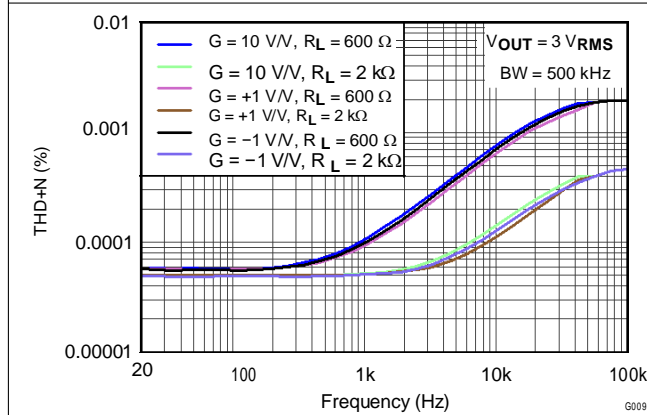
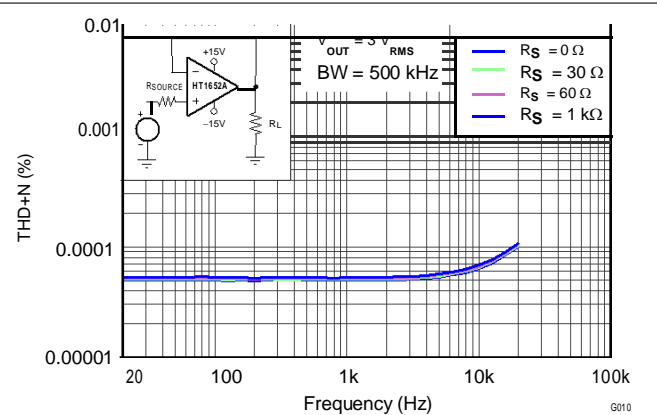
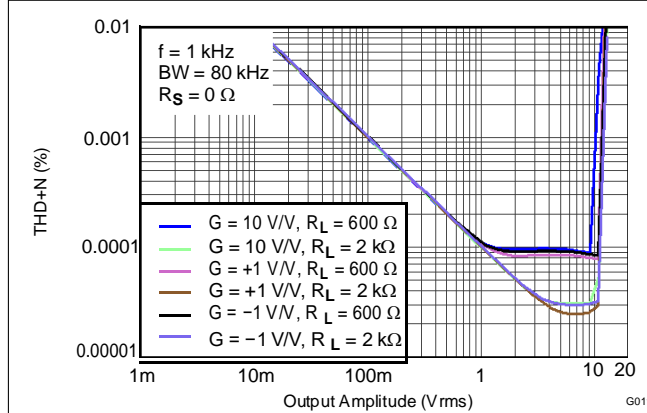
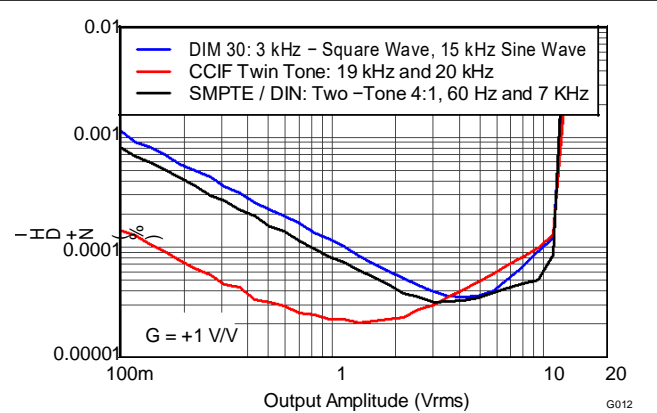
图 8. THD+N Ratio vs Frequency

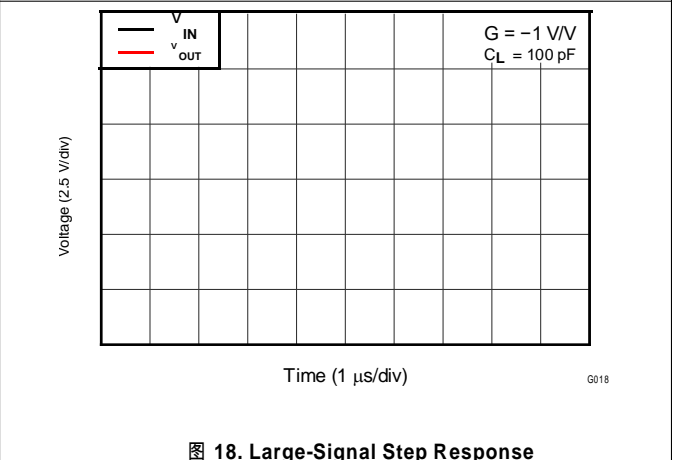
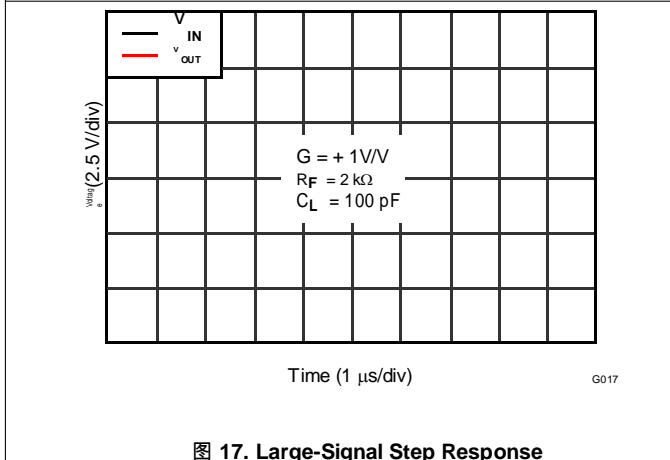
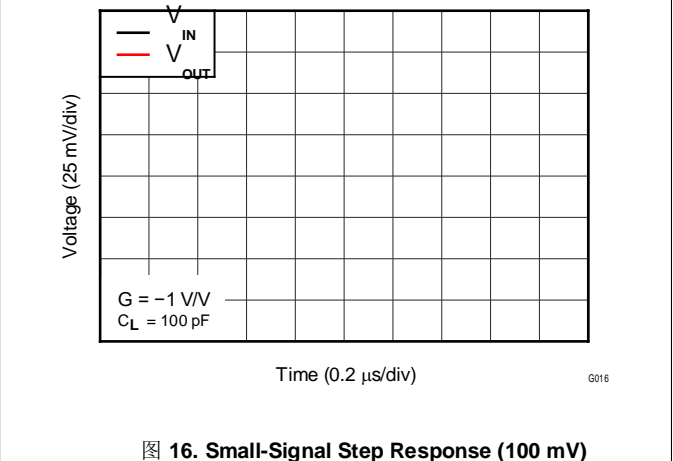
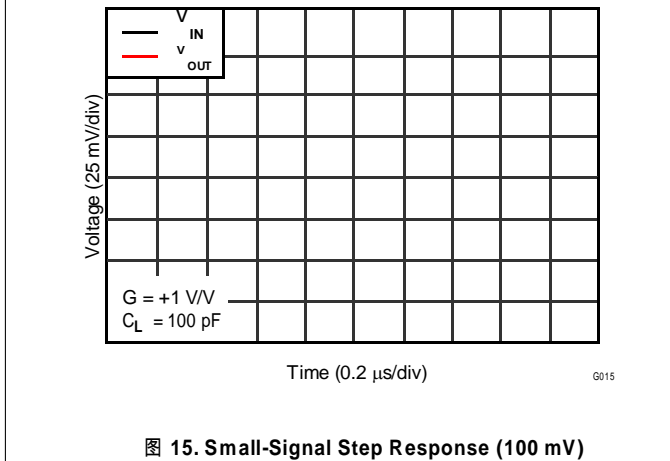
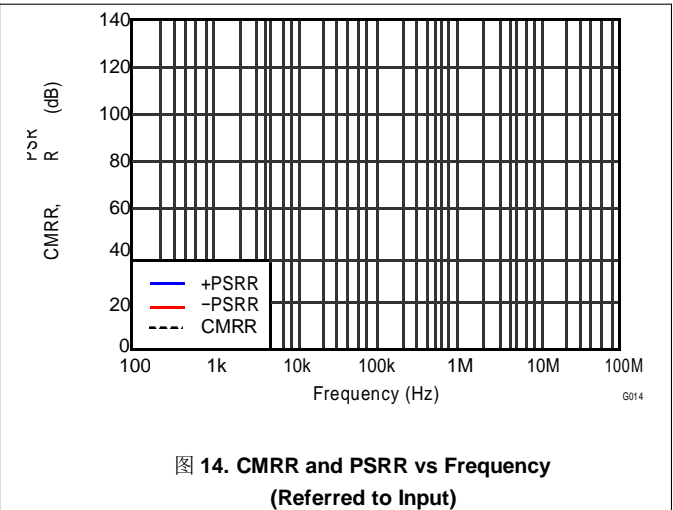
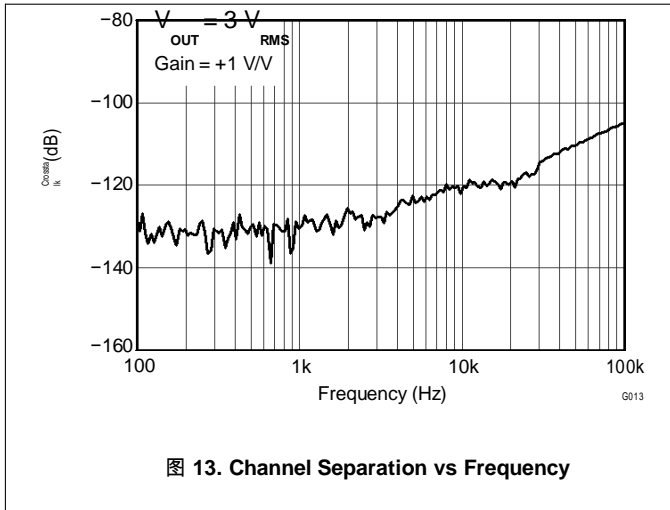
图 9. THD+N Ratio vs Frequency

图 10. THD+N Ratio vs Frequency

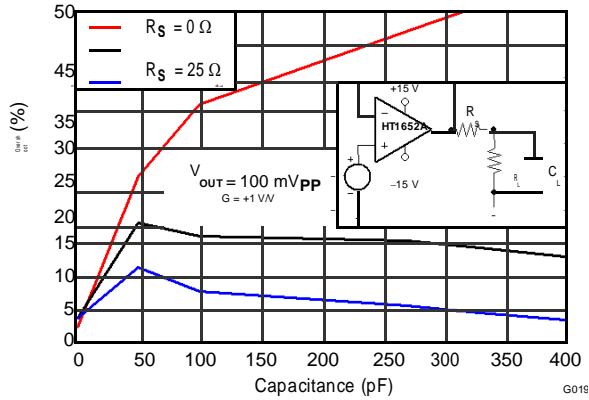
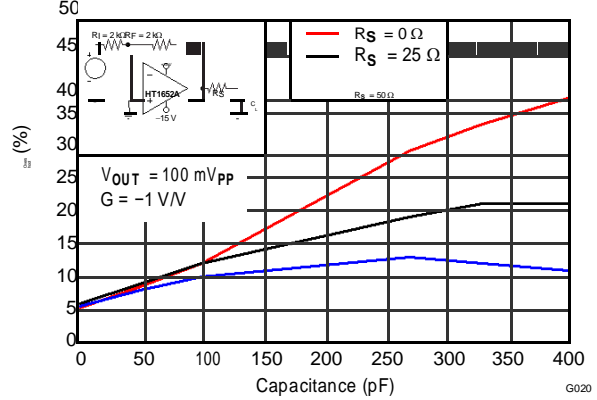
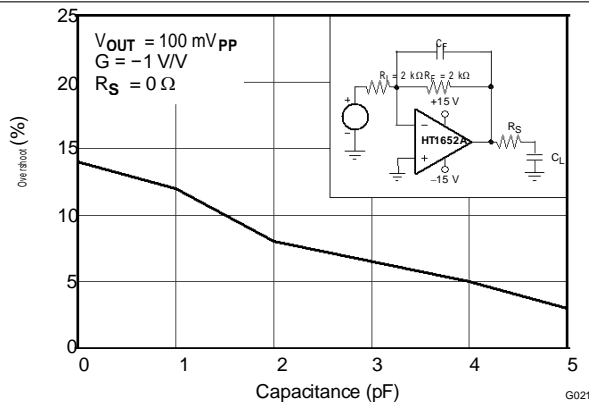
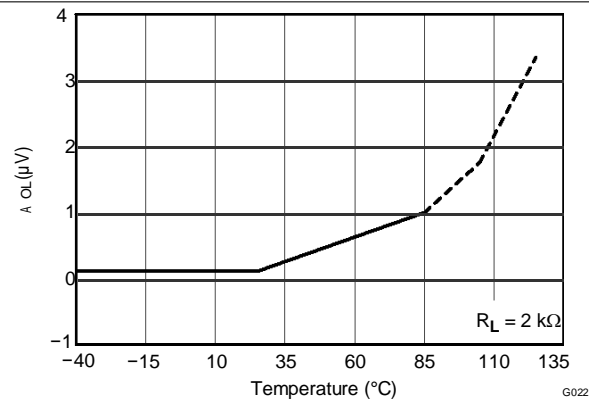
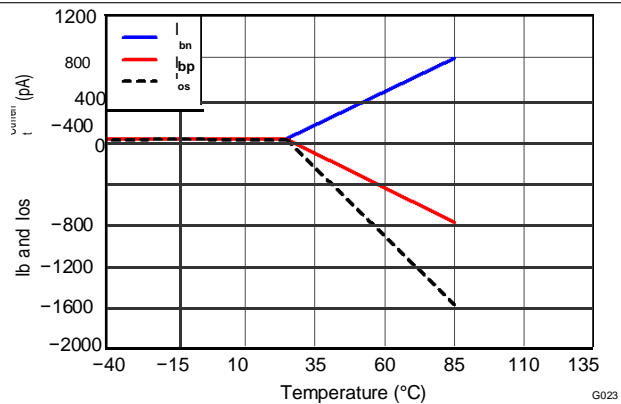
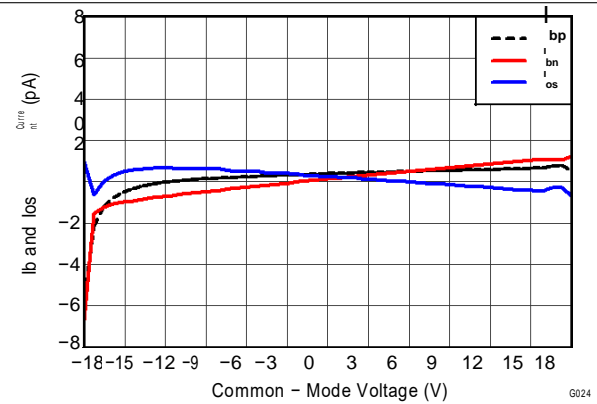
图 11. THD+N Ratio vs Output Amplitude

图 12. Intermodulation Distortion vs Output Amplitude

Typical Characteristics (接下页)

at $T_A = 25^\circ\text{C}$, $V_S = \pm 15\text{ V}$, and $R_L = 2\text{ k}\Omega$, unless otherwise noted.



Typical Characteristics (接下页)

 at $T_A = 25^\circ\text{C}$, $V_S = \pm 15\text{ V}$, and $R_L = 2\text{ k}\Omega$, unless otherwise noted.

图 19. Small-Signal Overshoot vs Capacitive Load

图 20. Small-Signal Overshoot vs Capacitive Load

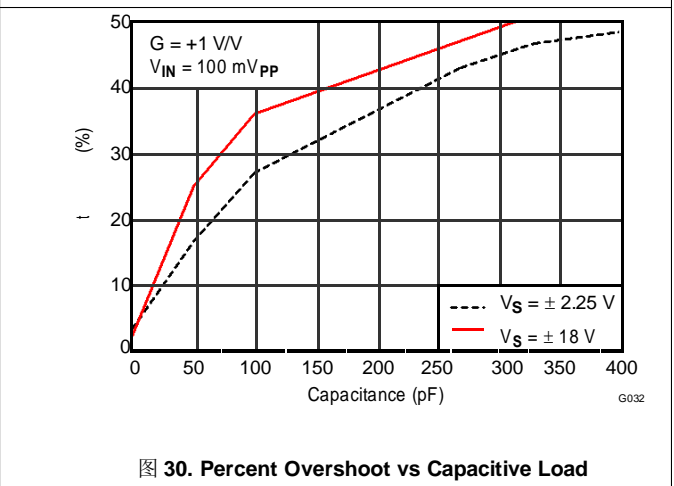
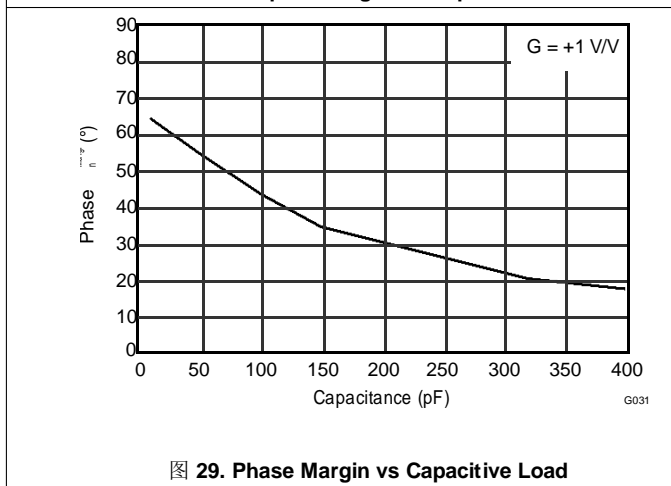
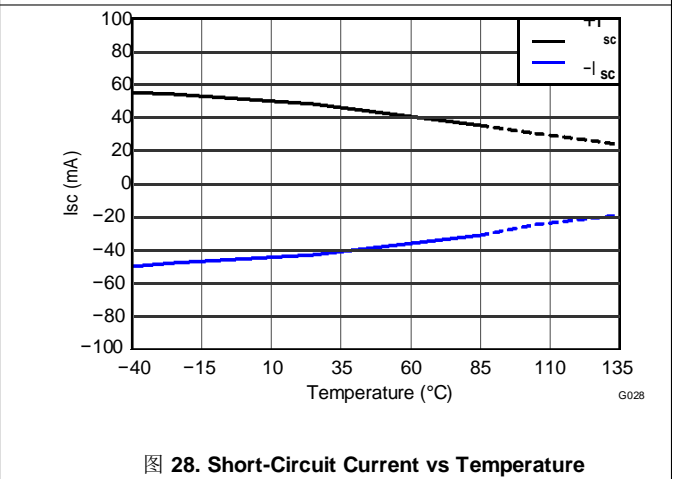
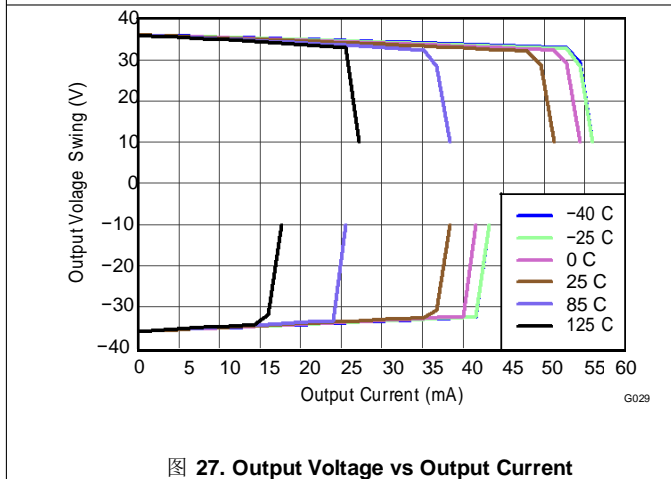
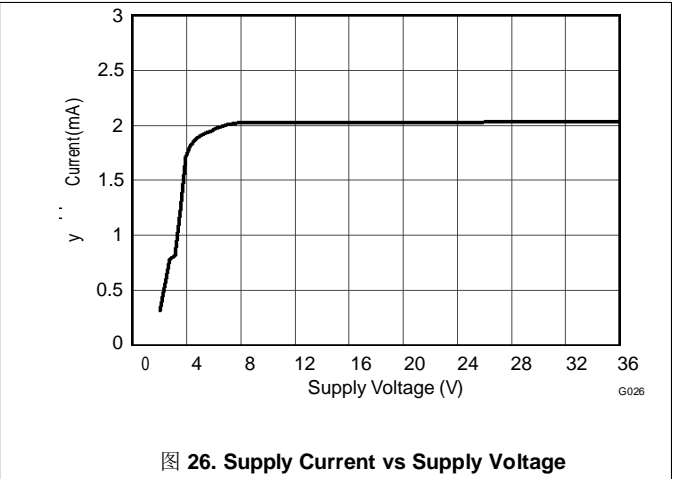
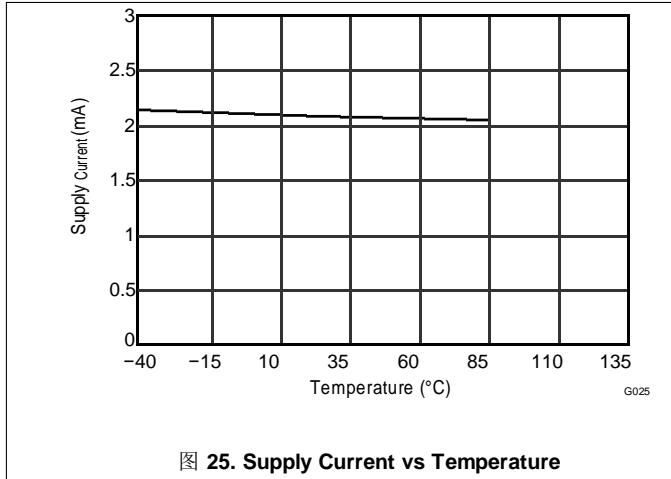
图 21. Small-Signal Overshoot vs Feedback Capacitor (100-mV Output Step)

图 22. Open-Loop Gain vs Temperature

图 23. IB and IOS vs Temperature

图 24. IB and IOS vs Common-Mode Voltage

Typical Characteristics (接下页)

at $T_A = 25^\circ\text{C}$, $V_S = \pm 15\text{ V}$, and $R_L = 2\text{ k}\Omega$, unless otherwise noted.



Typical Characteristics (接下页)

at $T_A = 25^\circ\text{C}$, $V_S = \pm 15\text{ V}$, and $R_L = 2\text{ k}\Omega$, unless otherwise noted.

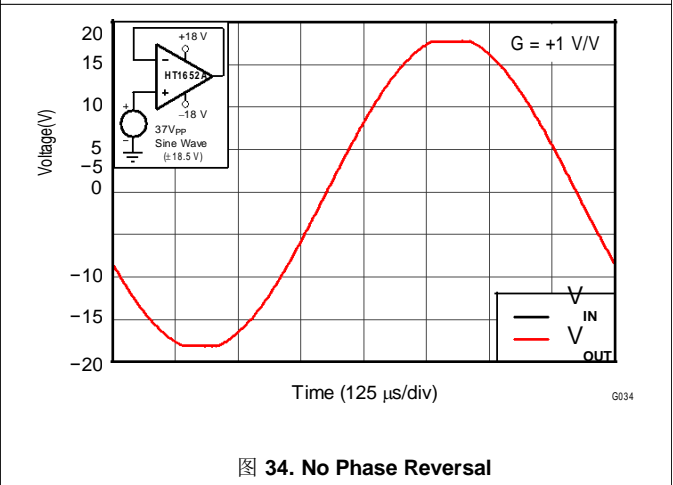
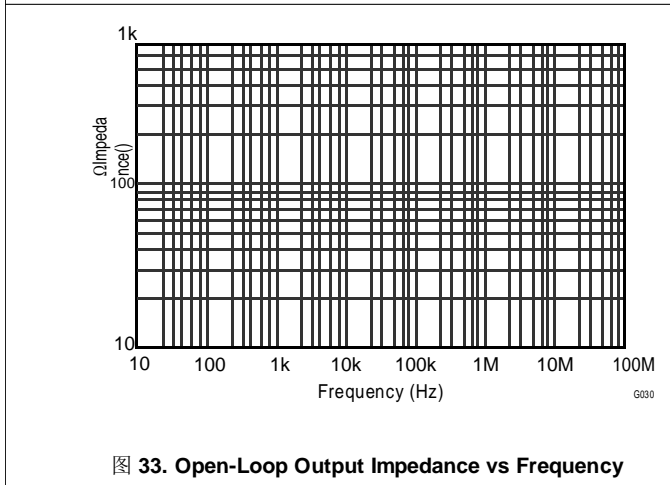
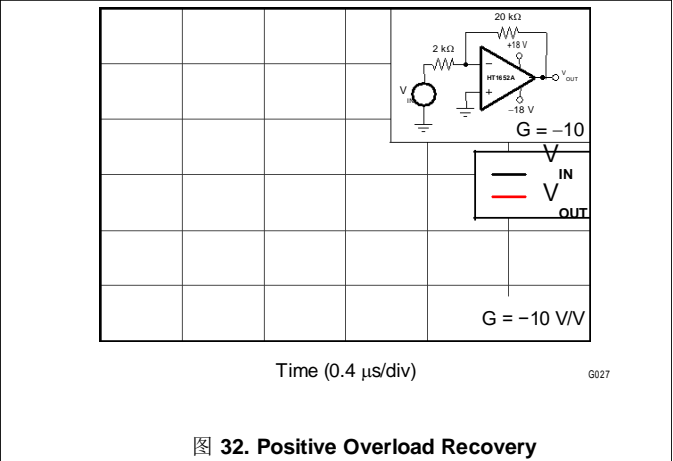
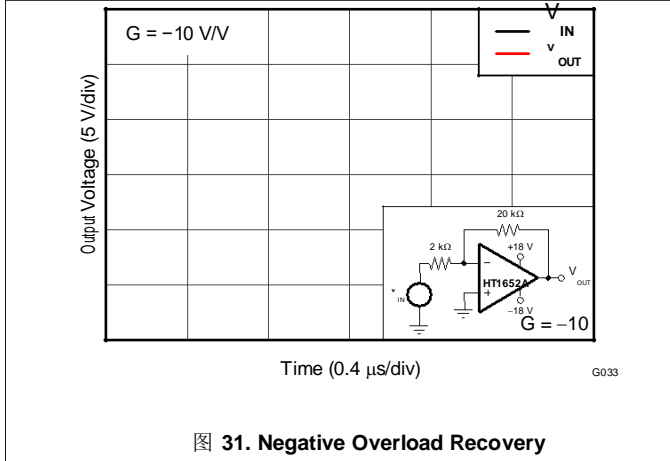

7 Detailed Description

7.1 Overview

The HT1652A and HT1654A are unity-gain stable, precision dual and quad op amps with very low noise. The [Functional Block Diagram](#) shows a simplified schematic of the OPA165x (with one channel shown). The device consists of a very low noise input stage with a folded cascode and a rail-to-rail output stage. This topology exhibits superior noise and distortion performance across a wide range of supply voltages not previously delivered by audio operational amplifiers.

7.2 Functional Block Diagram

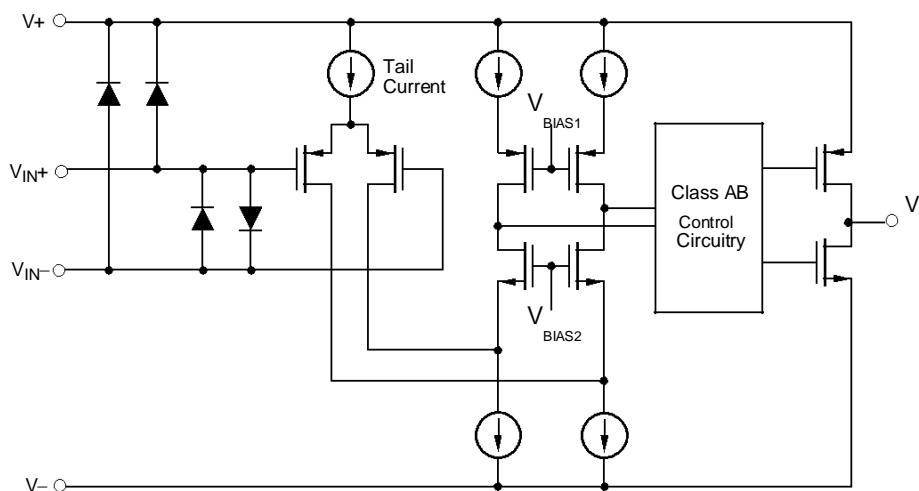

7.3 Feature Description

7.3.1 Phase Reversal Protection

The OPA165x family has internal phase-reversal protection. Many op amps exhibit phase reversal when the input is driven beyond the linear common-mode range. This condition is most often encountered in noninverting circuits when the input is driven beyond the specified common-mode voltage range, causing the output to reverse into the opposite rail. The input of the OPA165x prevents phase reversal with excessive common-mode voltage. Instead, the appropriate rail limits the output voltage. This performance is shown in [图 35](#).



图 35. Output Waveform Devoid of Phase Reversal During an Input Overdrive Condition

Feature Description (接下页)

7.3.2 Input Protection

The input terminals of the HT1652A and HT1654A are protected from excessive differential voltage with back-to-back diodes, as 图 36 illustrates. In most circuit applications, the input protection circuitry has no consequence. However, in low-gain or $G = 1$ circuits, fast ramping input signals can forward bias these diodes because the output of the amplifier cannot respond rapidly enough to the input ramp. If the input signal is fast enough to create this forward bias condition, the input signal current must be limited to 10 mA or less. If the input signal current is not inherently limited, an input series resistor (R_I) or a feedback resistor (R_F) can limit the signal input current. This resistor degrades the low-noise performance of the OPA165x, and is examined in the [Noise Performance](#) section. 图 36 shows an example configuration when both current-limiting input and feedback resistors are used.

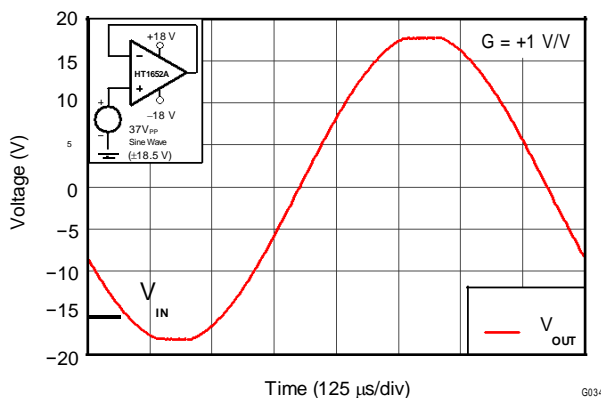

图 36. Pulsed Operation

7.3.3 Electrical Overstress

Designers typically ask questions about the capability of an operational amplifier to withstand electrical overstress. These questions tend to focus on the device inputs, but can involve the supply voltage pins or the output pin. Each of these different pin functions have electrical stress limits determined by the voltage breakdown characteristics of the particular semiconductor fabrication process and specific circuits connected to the pin. Additionally, internal electrostatic discharge (ESD) protection is built into these circuits to protect them from accidental ESD events both before and during product assembly.

A good understanding of this basic ESD circuitry and the relevance to an electrical overstress event is helpful. 图 37 illustrates the ESD circuits contained in the OPA165x (indicated by the dashed line area). The ESD protection circuitry involves several current-steering diodes connected from the input and output pins and routed back to the internal power-supply lines, where the diodes meet at an absorption device internal to the operational amplifier. This protection circuitry is intended to remain inactive during normal circuit operation.

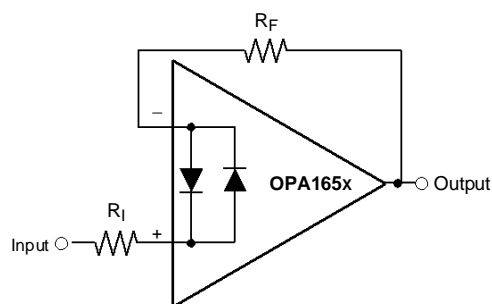
Feature Description (接下页)

图 37. Equivalent Internal ESD Circuitry Relative to a Typical Circuit Application

An ESD event produces a short-duration, high-voltage pulse that is transformed into a short-duration, high-current pulse when discharging through a semiconductor device. The ESD protection circuits are designed to provide a current path around the operational amplifier core to prevent damage. The energy absorbed by the protection circuitry is then dissipated as heat.

When an ESD voltage develops across two or more amplifier device pins, current flows through one or more steering diodes. The absorption device activates depending on the path that the current takes. The absorption device has a trigger, or threshold voltage, that is above the normal operating voltage of the OPA165x, but below the device breakdown voltage level. When this threshold is exceeded, the absorption device quickly activates and clamps the voltage across the supply rails to a safe level.

When the operational amplifier connects into a circuit (refer to 图 37), the ESD protection components are intended to remain inactive and do not become involved in the application circuit operation. However, circumstances may arise where an applied voltage exceeds the operating voltage range of a given pin. If this condition occurs, there is a risk that some internal ESD protection circuits can turn on and conduct current. Any such current flow occurs through steering-diode paths and rarely involves the absorption device.

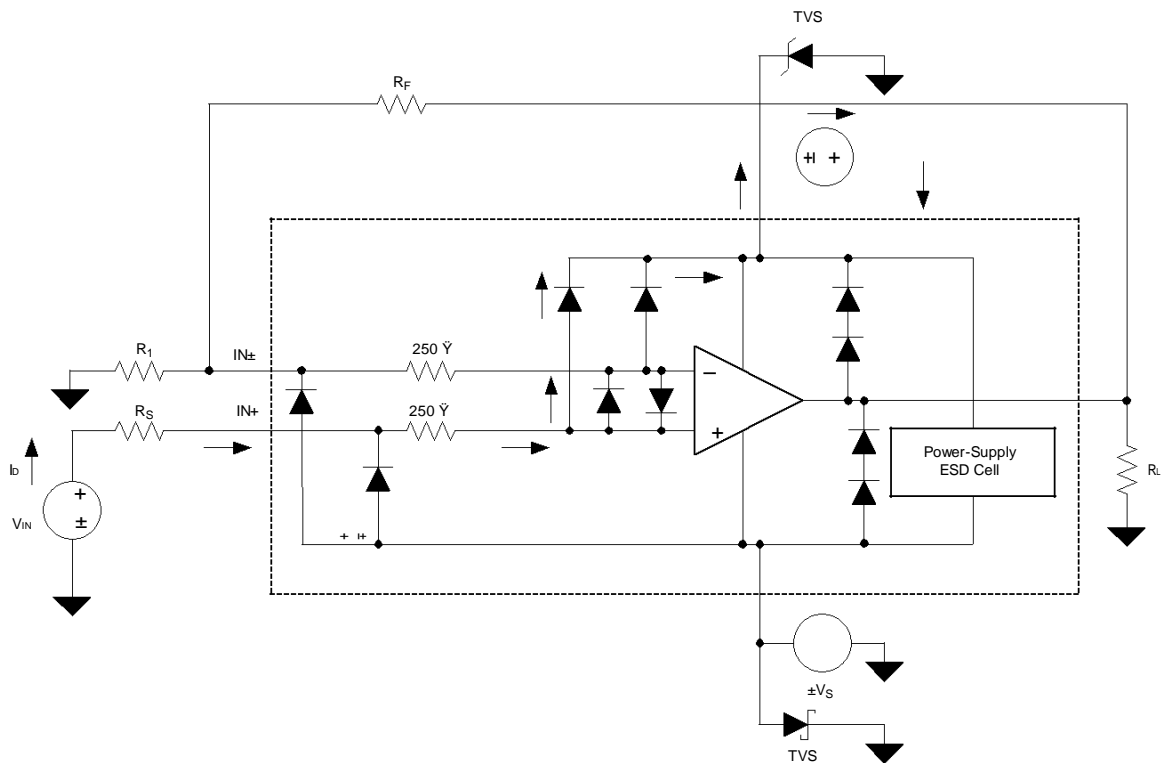
图 37 shows a specific example where the input voltage (V_{IN}) exceeds the positive supply voltage ($V+$) by 500 mV or more. Much of what happens in the circuit depends on the supply characteristics. If $V+$ can sink the current, one of the upper input steering diodes conducts and directs current to $V+$. Excessively high current levels can flow with increasingly higher V_{IN} . As a result, the data sheet specifications recommend that applications limit the input current to 10 mA.

If the supply is not capable of sinking the current, V_{IN} begins sourcing current to the operational amplifier, and then becomes the source of positive supply voltage. The danger in this case is that the voltage can rise to levels that exceed the absolute maximum ratings of the operational amplifier.

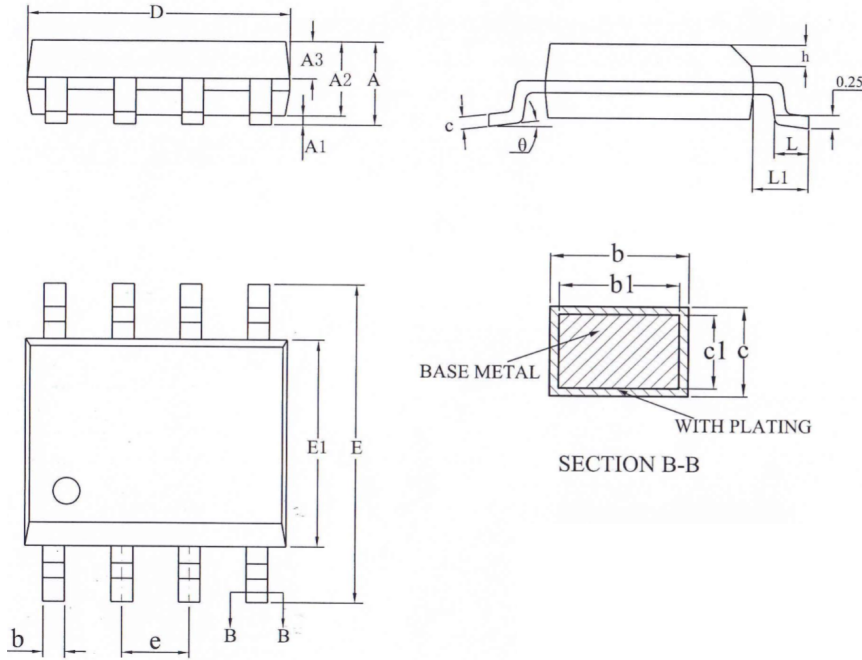
SOP8

| SYMBOL | MILLIMETER | | |
|----------|------------|------|-------|
| | MIN | NOM | MAX |
| A | — | — | 1.75 |
| A1 | 0.10 | — | 0.225 |
| A2 | 1.30 | 1.40 | 1.50 |
| A3 | 0.60 | 0.65 | 0.70 |
| b | 0.39 | — | 0.47 |
| b1 | 0.38 | 0.41 | 0.44 |
| c | 0.20 | — | 0.24 |
| c1 | 0.19 | 0.20 | 0.21 |
| D | 4.80 | 4.90 | 5.00 |
| E | 5.80 | 6.00 | 6.20 |
| E1 | 3.80 | 3.90 | 4.00 |
| e | 1.27BSC | | |
| h | 0.25 | — | 0.50 |
| L | 0.50 | — | 0.80 |
| L1 | 1.05REF | | |
| θ | 0 | — | 8° |

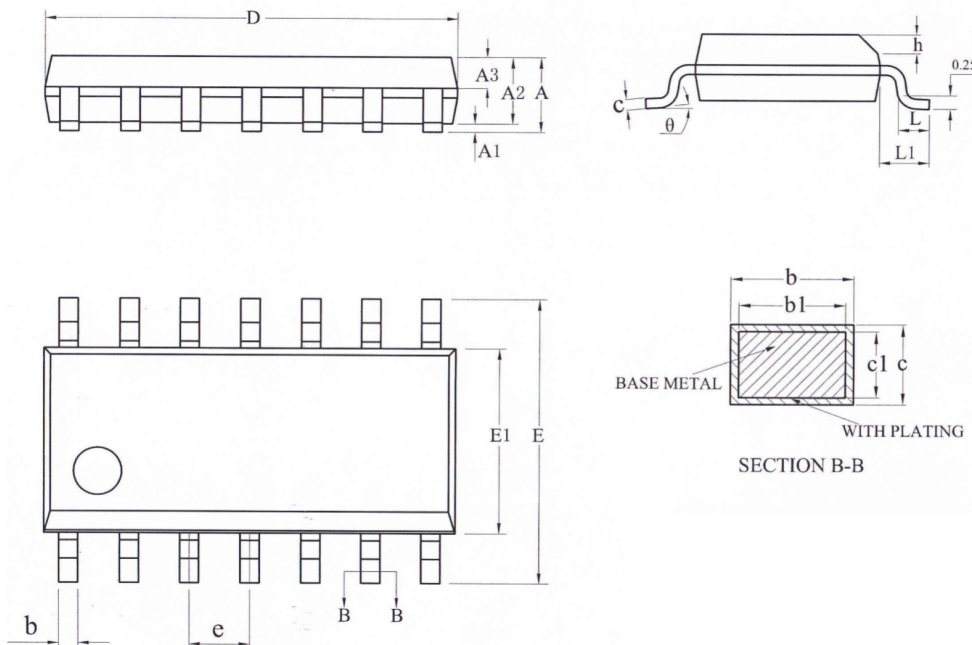
SOP14

| SYMBOL | MILLIMETER | | |
|----------|------------|------|-------|
| | MIN | NOM | MAX |
| A | — | — | 1.75 |
| A1 | 0.05 | — | 0.225 |
| A2 | 1.30 | 1.40 | 1.50 |
| A3 | 0.60 | 0.65 | 0.70 |
| b | 0.39 | — | 0.47 |
| b1 | 0.38 | 0.41 | 0.44 |
| c | 0.20 | — | 0.24 |
| c1 | 0.19 | 0.20 | 0.21 |
| D | 8.55 | 8.65 | 8.75 |
| E | 5.80 | 6.00 | 6.20 |
| E1 | 3.80 | 3.90 | 4.00 |
| e | 1.27BSC | | |
| h | 0.25 | — | 0.50 |
| L | 0.50 | — | 0.80 |
| L1 | 1.05REF | | |
| θ | 0 | — | 8° |