

ATM8205DNPD

Dual N-Channel Enhancement Mode Power MOSFET

Drain-Source Voltage:20V Continuous Drain Current:5A

Descriptions

The ATM8205DNPD uses advanced trench technology to provide excellent $R_{DS(ON)}$, low gate charge and operation with gate voltages as low as 2.5V. This device is suitable for use as a battery protection or in other switching application.

TSSOP8



Features

- $V_{DS}=20V, I_D=5A$
Typ. $R_{DS(ON)}=20m\Omega @ V_{GS}=4.5V$
Typ. $R_{DS(ON)}=25m\Omega @ V_{GS}=2.5V$
- High power and current handling capability
- Lead free product is acquired
- Surface mount package



Applications

- Battery protection
- Load switch
- Power management

Absolute Maximum Ratings (Ta=25°C unless otherwise specified)

Parameter	Symbol	Limit	Units
Drain-Source Voltage	V_{DS}	20	V
Gate-Source Voltage	V_{GS}	± 12	V
Drain Current-Continuous	I_D	5	A
Drain Current-Pulsed	I_{DM}	25	A
Maximum Power Dissipation	PD	1.25	W
Operating Junction and Storage Temperature Range	T_J, T_{STG}	150, -55 ~ +150	°C
Thermal Resistance, Junction-to-Ambient	$R_{\theta JA}$	100	°C/W

ATM8205DNPD

Electrical Characteristics (Ta=25°C unless otherwise specified)

Parameter	Symbol	Test Conditions	Min	Typ	Max	Unit
Static Parameters						
Drain-Source breakdown voltage	BVDSS	ID=250uA, VGS=0V	20	-	-	V
Zero Gate voltage drain current	IDSS	VDS=20V, VGS=0V	-	-	1	uA
Gate-Body leakage current	IGSS	VDS=0V, VGS=±12V	-	-	±100	nA
Gate Threshold voltage	VGS(th)	VGS=VDS, ID=250uA	0.5	0.7	1.2	V
Static Drain-source on-resistance	RDS(on)	VGS=2.5V, ID=4A	-	25	32	mΩ
		VGS=4.5V, ID=5A	-	20	25	mΩ
Forward Transconductance	gFS	VDS=5V, ID=5A	-	10	-	s
Dynamic Parameters						
Input Capacitance	Ciss	VGS=0V, VDS=10V, f=1MHZ	-	550	-	pF
Output capacitance	Coss		-	125	-	pF
Reverse transfer capacitance	Crss		-	64	-	pF
Switching Parameters						
Total Gate charge	Qg	VGS=4.5V, VDS=10V, ID=5A	-	9.5	-	nC
Gate Source charge	Qgs		-	2.1	-	nC
Gate Drain charge	Qgd		-	1.4	-	nC
Turn-on delaytime	tD(on)	VGS=4V, VDD=10V, ID=5A, RGEN=10Ω	-	9	-	ns
Turn-on rise time	tr		-	10	-	ns
Turn-off delaytime	tD(off)		-	32	-	ns
Turn-off fall time	tf		-	24	-	ns
Source-Drain diode parameters						
Body diode forward voltage	VSD	IS=5A, VGS=0V	-	0.8	1.2	V
Body diode continuous source current	IS		-	-	5	A

Notes:

1. Repetitive Rating: Pulse width limited by maximum junction temperature.
2. Surface Mounted on FR4 Board, t ≤ 10 sec.
3. Pulse Test: Pulse Width ≤ 300μs, Duty Cycle ≤ 2%.

ATM8205DNPD

Typical Characteristics Curves

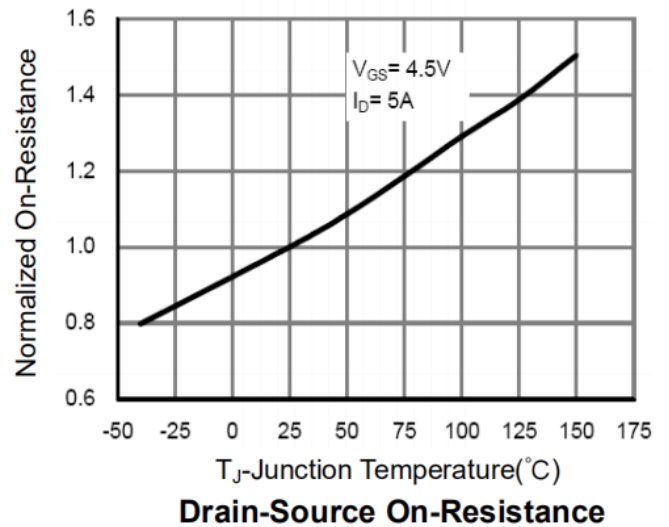
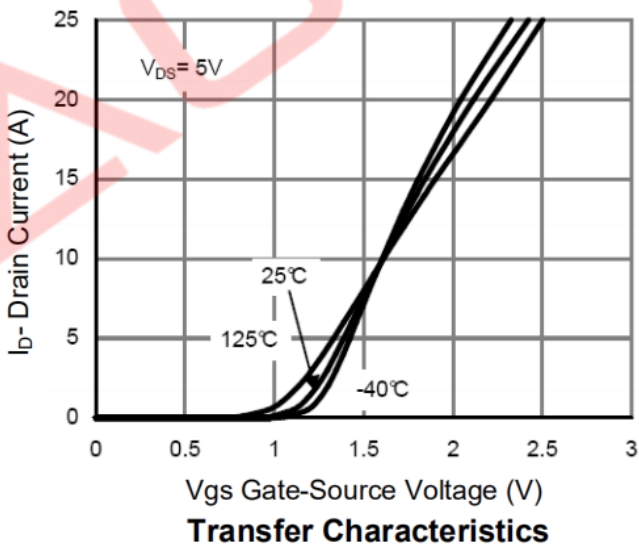
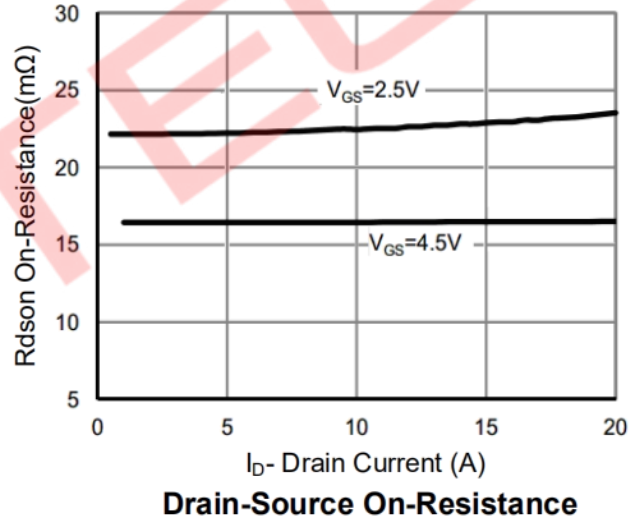
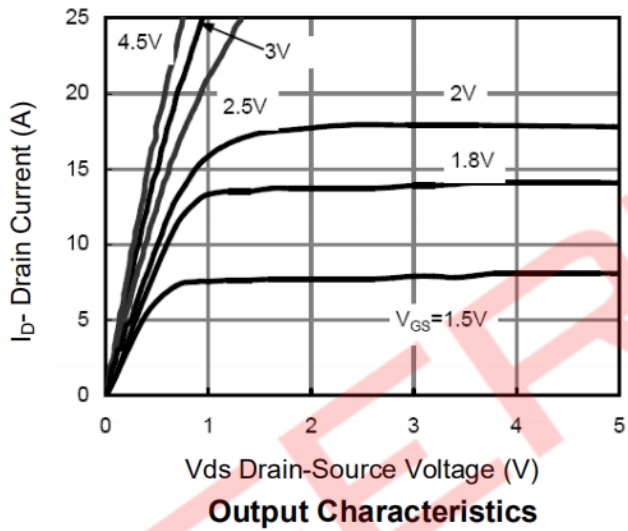
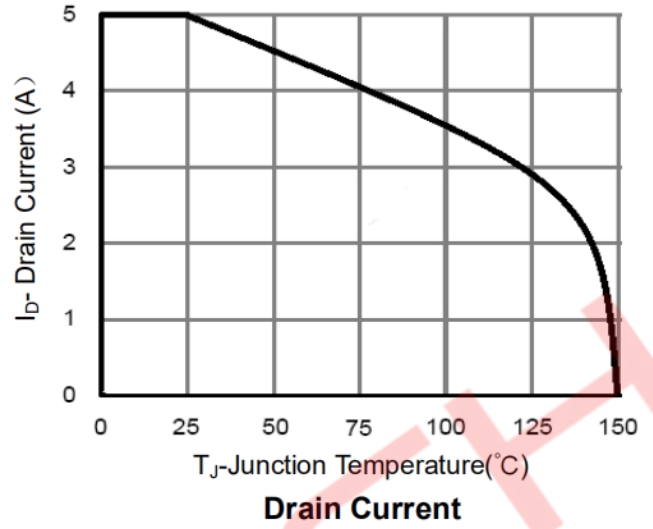
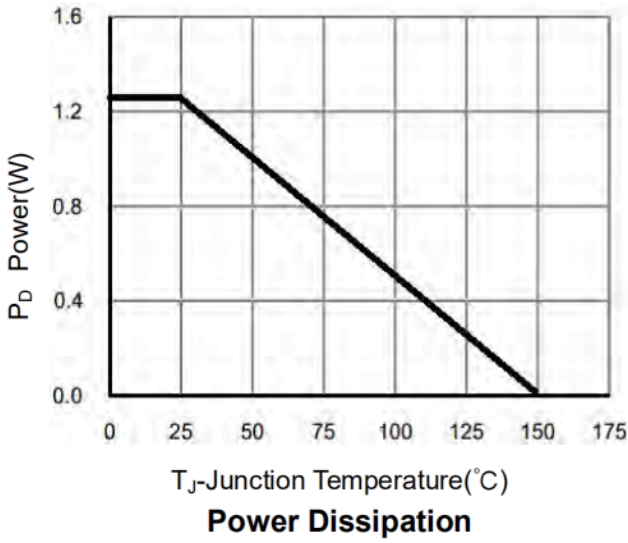

ATM8205DNP

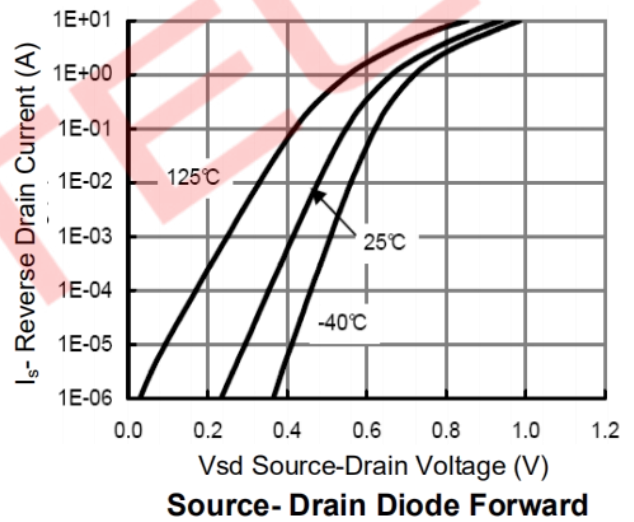
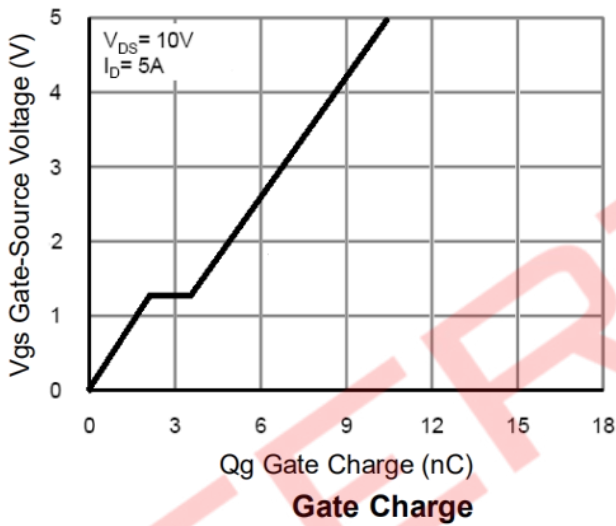
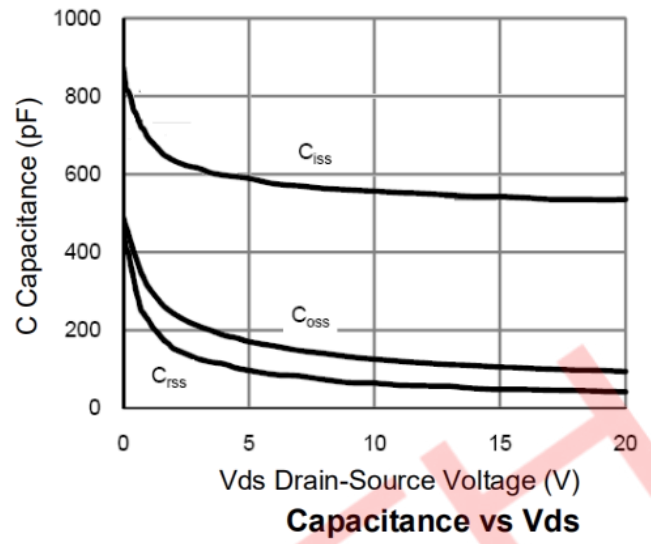
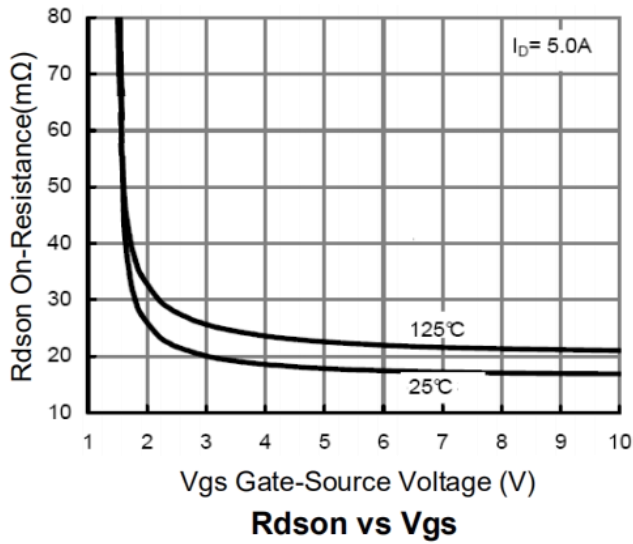

ATM8205DNPD

Package outline

TSSOP8

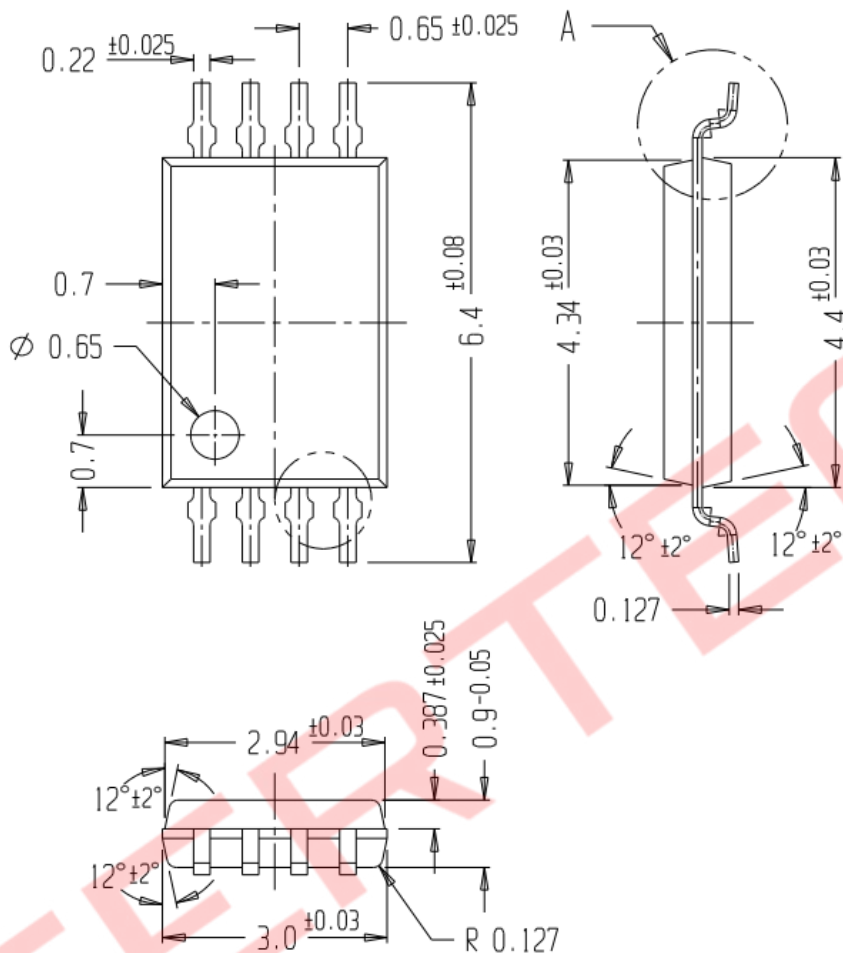

Ordering information

Device	Package	Shipping
ATM8205DNPD	TSSOP8	3000PCS/Reel&Tape(13inch)