

AT6211 Series

High Speed LDO Regulators, High PSRR, Low noise

Product Summary

The AT6211 series are highly accurate, low noise, CMOS LDO Voltage Regulators. Offering low output noise, high ripple rejection ratio, low dropout and very fast turn-on times, the AT6211 series is ideal for today's cutting edge mobile phone. Internally the AT6211 includes a reference voltage source, error amplifiers, driver transistors, current limiters and phase compensators. The AT6211's current limiters' foldback circuit also operates as a short protect for the output current limiter and the output pin. The AT6211 series is also fully compatible with low ESR ceramic capacitors, reducing cost and improving output stability. This high level of output stability is maintained even during frequent load fluctuations, due to the excellent transient response performance and high PSRR achieved across a broad range of frequencies. The CE function allows the output of regulator to be turned off, resulting in greatly reduced power consumption.

Features

- Maximum Output Current: 500mA
($V_{in}=4.3V, V_{out}=3.3V$)
- Operating Voltage Range: 1.2V~6.0V
- Dropout Voltage: 100mV@ $I_{out}=100mA$
- High Accuracy: $\pm 1\%$
- Low Power Consumption: 30uA (TYP.)
- Standby Current: 0.1uA (TYP.)
- High Ripple Rejection: 70dB@1KHz (AT6211C33)
- Low output noise: 50uVrms
- Line Regulation: 0.05% (TYP.)

Applications

- Mobile phones
- Cordless phones, radio communication equipment
- Portable games
- Cameras, Video cameras
- Reference voltage sources
- Battery-Powered Equipment

Package

- 3-pin SOT89-3, SOT23-3
- 5-pin SOT23-5

AT6211 Series

Typical Application Circuit

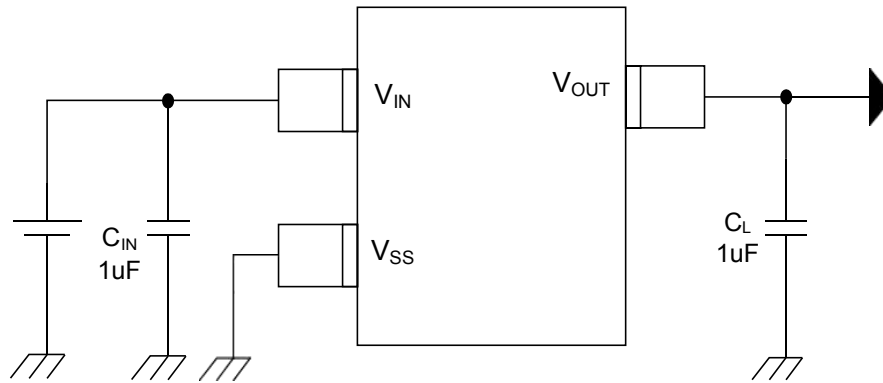

Fig1. AT6211A series

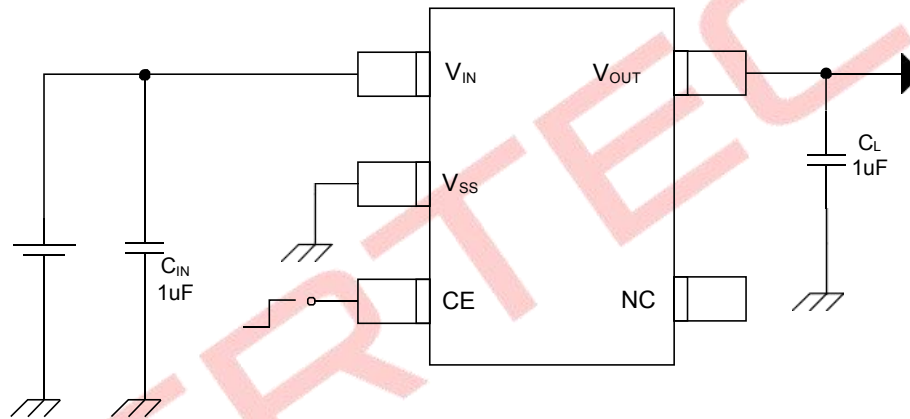

Fig2. AT6211C series

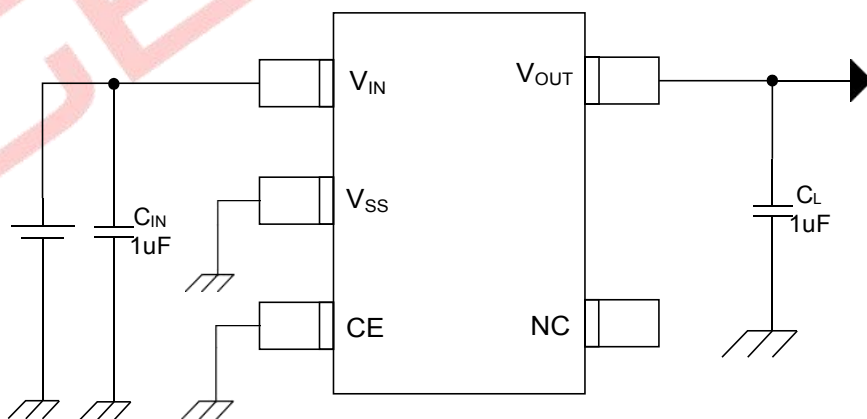
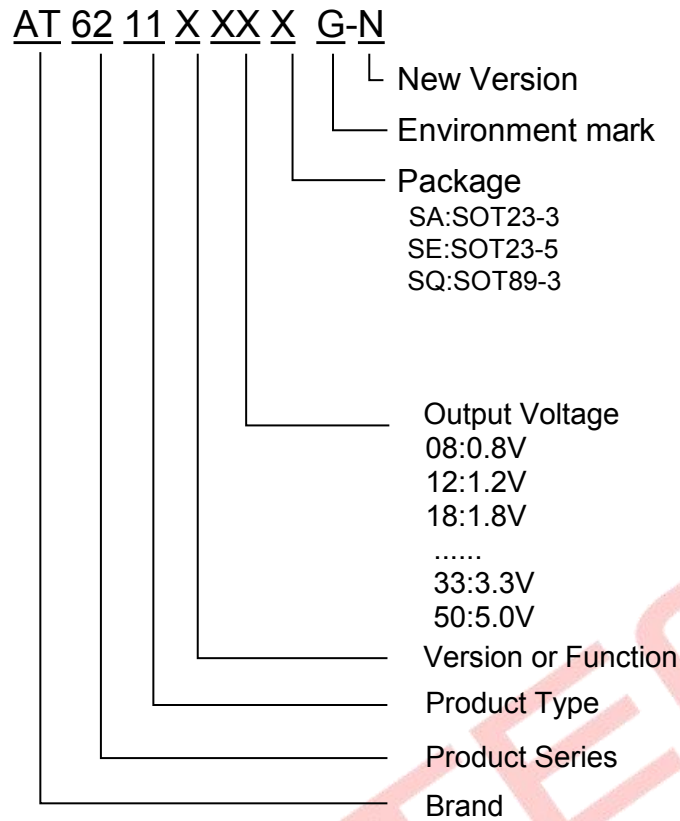

Fig3. AT6211H series

AT6211 Series

Selection Guide



product series	product function	Output voltage	Package
AT6211A12SQG-N	Enable the internal connection of high	1.2V	SOT89-3
AT6211C33SEG-N	Enable can be set	3.3V	SOT23-5
AT6211H15SEG-N	Enable connected to a low	1.5V	SOT23-5

Marking:

11X¹XX
ATYWX

11:Product Type

X¹:Version or Function

XX:Output Voltage

AT:Brand

YWX:Code

AT6211 Series

Pin Configuration

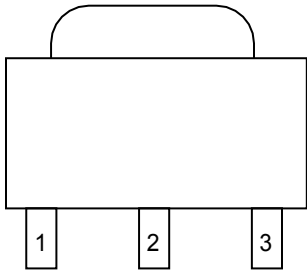

SOT89-3

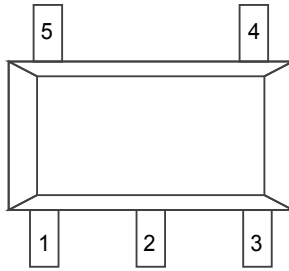

SOT23-5

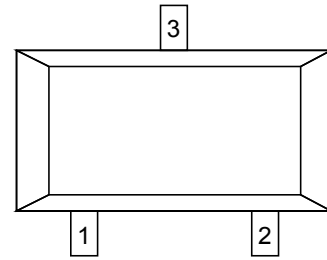

SOT23-3

AT6211AXXG

Pin Number		Pin Name	Functions
SA	SQ		
SOT23-3	SOT89-3		
1	1	V_{SS}	Ground
2	3	V_{OUT}	Output
3	2	V_{IN}	Power Input

AT6211CXXG/ AT6211HXXG

Pin Number		Pin Name	Functions
SE	SOT23-5		
1	1	V_{IN}	Power Input
2	2	V_{SS}	Ground
3	3	CE	ON / OFF Control
4	4	NC	No Connect
5	5	V_{OUT}	Output

AT6211 Series

Block Diagram

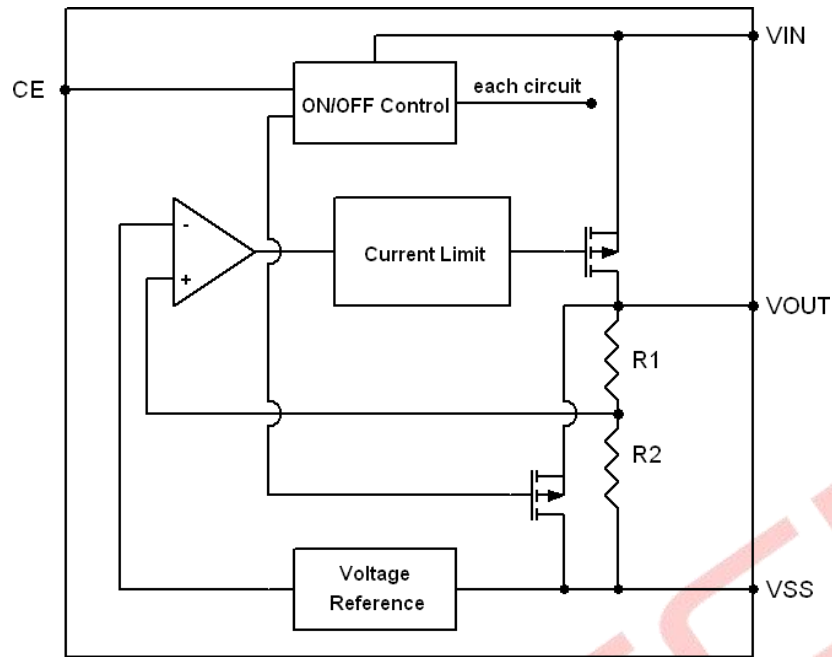

Absolute Maximum Ratings ($T_a=25^{\circ}\text{C}$, unless otherwise noted)

Parameter	Symbol	Ratings	Units
Input Voltage	V_{IN}	6.5	V
Output Current	I_{OUT}	600	mA
Output Voltage	V_{OUT}	$V_{SS}-0.3 \sim V_{IN} + 0.3$	V
CE Pin Voltage	V_{CE}	$V_{SS}-0.3 \sim V_{IN} + 0.3$	V
Power Dissipation	SOT23-3	0.54	W
	SOT23-5	0.60	
	SOT89-3	1.25	
Thermal resistance (Junction to air)	SOT23-3	230	$^{\circ}\text{C/W}$
	SOT23-5	210	
	SOT89-3	100	
Operating Ambient Temperature Range	T_{OPR}	-40 ~ +85	$^{\circ}\text{C}$
Storage Temperature Range	T_{STG}	-55 ~ +150	$^{\circ}\text{C}$
Junction temperature	T_J	-40 ~ +150	$^{\circ}\text{C}$

AT6211 Series

Electrical Characteristics ($V_{IN}=V_{OUT}+1V$, $C_{IN}=C_{OUT}=1\mu F$, $T_A=25^\circ C$, unless otherwise specified)

AT6211C08 ($V_{IN}=V_{OUT}+1V$, $V_{CE}=V_{IN}$, $C_{IN}=C_L=1\mu F$, $T_a=25^\circ C$, unless otherwise noted)

Parameter	Symbol	Conditions	Min.	Typ.	Max.	Units
Output Voltage	$V_{OUT(E)}$ (Note 2)	$I_{OUT}=30mA$, $V_{IN}=V_{OUT}+1V$	X 0.99	$V_{OUT(T)}$ (Note 1)	X 1.01	V
Maximum Output Current	I_{OUTMAX}	$V_{IN}=V_{OUT}+1V$		250		mA
Load Regulation	ΔV_{OUT}	$V_{IN}=V_{OUT}+1V$, $1mA \leq I_{OUT} \leq 100mA$		7		mV
Dropout Voltage (Note 3)	V_{DIF1}	$I_{OUT}=100mA$		600		mV
	V_{DIF2}	$I_{OUT}=200mA$		850		mV
Supply Current	I_{SS}	$V_{IN}=V_{OUT}+1V$		30	60	μA
Stand-by Current	I_{CEL}	$V_{CE}=0V$		0.1	1.0	μA
Line Regulation	$\frac{\Delta V_{OUT}}{\Delta V_{IN} \cdot V_{OUT}}$	$I_{OUT}=30mA$ $V_{OUT}+1V \leq V_{IN} \leq 6.5V$		0.05		%/V
CE "High" Voltage	VCEH	Start up	1.0			V
CE "Low" Voltage	VCEL	Shut down			0.5	V
Output noise	EN	$I_{OUT}=40mA$, 300Hz~50kHz		50		μV_{rms}
Ripple Rejection Rate	PSRR	$V_{IN}=[V_{OUT}+1]V$ $+1V_{p-pAC}$	$I_{OUT}=10mA$, 1kHz	70		dB
			$I_{OUT}=100mA$, 10kHz	62		

AT6211C10 ($V_{IN}=V_{OUT}+1V$, $V_{CE}=V_{IN}$, $C_{IN}=C_L=1\mu F$, $T_a=25^\circ C$, unless otherwise noted)

Parameter	Symbol	Conditions	Min.	Typ.	Max.	Units
Output Voltage	$V_{OUT(E)}$ (Note 2)	$I_{OUT}=30mA$, $V_{IN}=V_{OUT}+1V$	X 0.99	$V_{OUT(T)}$ (Note 1)	X 1.01	V
Maximum Output Current	I_{OUTMAX}	$V_{IN}=V_{OUT}+1V$		300		mA
Load Regulation	ΔV_{OUT}	$V_{IN}=V_{OUT}+1V$, $1mA \leq I_{OUT} \leq 100mA$		5		mV
Dropout Voltage (Note 3)	V_{DIF1}	$I_{OUT}=100mA$		400		mV
	V_{DIF2}	$I_{OUT}=200mA$		650		mV
Supply Current	I_{SS}	$V_{IN}=V_{OUT}+1V$		30	60	μA
Stand-by Current	I_{CEL}	$V_{CE}=0V$		0.1	1.0	μA
Line Regulation	$\frac{\Delta V_{OUT}}{\Delta V_{IN} \cdot V_{OUT}}$	$I_{OUT}=30mA$ $V_{OUT}+1V \leq V_{IN} \leq 6.5V$		0.035		%/V
CE "High" Voltage	VCEH	Start up	1.0			V
CE "Low" Voltage	VCEL	Shut down			0.5	V
Output noise	EN	$I_{OUT}=40mA$, 300Hz~50kHz		50		μV_{rms}
Ripple Rejection Rate	PSRR	$V_{IN}=[V_{OUT}+1]V$ $+1V_{p-pAC}$	$I_{OUT}=10mA$, 1kHz	70		dB
			$I_{OUT}=100mA$, 10kHz	62		

AT6211 Series

AT6211C12 ($V_{IN} = V_{OUT} + 1V$, $V_{CE} = V_{IN}$, $C_{IN} = C_L = 1\mu F$, $T_a = 25^\circ C$, unless otherwise noted)

Parameter	Symbol	Conditions	Min.	Typ.	Max.	Units
Output Voltage	$V_{OUT(E)}$ (Note 2)	$I_{OUT} = 30mA$, $V_{IN} = V_{OUT} + 1V$	X 0.99	$V_{OUT(T)}$ (Note 1)	X 1.01	V
Maximum Output Current	I_{OUTMAX}	$V_{IN} = V_{OUT} + 1V$		300		mA
Load Regulation	ΔV_{OUT}	$V_{IN} = V_{OUT} + 1V$, $1mA \leq I_{OUT} \leq 100mA$		8		mV
Dropout Voltage (Note 3)	V_{DIF1}	$I_{OUT} = 100mA$		280		mV
	V_{DIF2}	$I_{OUT} = 200mA$		500		mV
Supply Current	I_{SS}	$V_{IN} = V_{OUT} + 1V$		30	60	μA
Stand-by Current	I_{CEL}	$V_{CE} = 0V$		0.1	1.0	μA
Line Regulation	$\frac{\Delta V_{OUT}}{\Delta V_{IN} \cdot V_{OUT}}$	$I_{OUT} = 30mA$ $V_{OUT} + 1V \leq V_{IN} \leq 6.5V$		0.03		%/V
CE "High" Voltage	VCEH	Start up	1.0			V
CE "Low" Voltage	VCEL	Shut down			0.5	V
Output noise	EN	$I_{OUT} = 40mA$, 300Hz~50kHz		50		μV_{rms}
Ripple Rejection Rate	PSRR	$V_{IN} = [V_{OUT} + 1]V$ +1Vp-pAC	$I_{OUT} = 10mA$, 1kHz	70		dB
			$I_{OUT} = 100mA$, 10kHz	62		

AT6211C15 ($V_{IN} = V_{OUT} + 1V$, $V_{CE} = V_{IN}$, $C_{IN} = C_L = 1\mu F$, unless otherwise noted)

Parameter	Symbol	Conditions	Min.	Typ.	Max.	Units
Output Voltage	$V_{OUT(E)}$ (Note 2)	$I_{OUT} = 30mA$, $V_{IN} = V_{OUT} + 1V$	X 0.99	$V_{OUT(T)}$ (Note 1)	X 1.01	V
Maximum Output Current	I_{OUTMAX}	$V_{IN} = V_{OUT} + 1V$		300		mA
Load Regulation	ΔV_{OUT}	$V_{IN} = V_{OUT} + 1V$, $1mA \leq I_{OUT} \leq 100mA$		9		mV
Dropout Voltage (Note 3)	V_{DIF1}	$I_{OUT} = 100mA$		200		mV
	V_{DIF2}	$I_{OUT} = 200mA$		400		mV
Supply Current	I_{SS}	$V_{IN} = V_{OUT} + 1V$		30	60	μA
Stand-by Current	I_{CEL}	$V_{CE} = 0V$		0.1	1.0	μA
Line Regulation	$\frac{\Delta V_{OUT}}{\Delta V_{IN} \cdot V_{OUT}}$	$I_{OUT} = 30mA$ $V_{OUT} + 1V \leq V_{IN} \leq 6.5V$		0.05		%/V
CE "High" Voltage	VCEH	Shut up	1.0			V
CE "Low" Voltage	VCEL	Start down			0.5	V
Output noise	EN	$I_{OUT} = 40mA$, 300Hz~50kHz		50		μV_{rms}
Ripple Rejection Rate	PSRR	$V_{IN} = [V_{OUT} + 1]V$ +1Vp-pAC	$I_{OUT} = 10mA$, 1kHz	70		dB
			$I_{OUT} = 100mA$, 10kHz	62		

AT6211 Series

AT6211C18 ($V_{IN} = V_{OUT} + 1V$, $V_{CE} = V_{IN}$, $C_{IN} = C_L = 1\mu F$, $T_a = 25^\circ C$, unless otherwise noted)

Parameter	Symbol	Conditions	Min.	Typ.	Max.	Units
Output Voltage	$V_{OUT(E)}$ (Note 2)	$I_{OUT} = 30mA$, $V_{IN} = V_{OUT} + 1V$	X 0.99	$V_{OUT(T)}$ (Note 1)	X 1.01	V
Maximum Output Current	I_{OUTMAX}	$V_{IN} = V_{OUT} + 1V$		300		mA
Load Regulation	ΔV_{OUT}	$V_{IN} = V_{OUT} + 1V$, $1mA \leq I_{OUT} \leq 100mA$		9		mV
Dropout Voltage (Note 3)	V_{DIF1}	$I_{OUT} = 100mA$		200		mV
	V_{DIF2}	$I_{OUT} = 200mA$		400		mV
Supply Current	I_{SS}	$V_{IN} = V_{OUT} + 1V$		30	60	μA
Stand-by Current	I_{CEL}	$V_{CE} = 0V$		0.1	1.0	μA
Line Regulation	$\frac{\Delta V_{OUT}}{\Delta V_{IN} \cdot V_{OUT}}$	$I_{OUT} = 30mA$ $V_{OUT} + 1V \leq V_{IN} \leq 6.5V$		0.05		%/V
CE "High" Voltage	VCEH	Start up	1.0			V
CE "Low" Voltage	VCEL	Shut down			0.5	V
Output noise	EN	$I_{OUT} = 40mA$, 300Hz~50kHz		50		μV_{rms}
Ripple Rejection Rate	PSRR	$V_{IN} = [V_{OUT} + 1]V$ $+1V_{p-pAC}$	$I_{OUT} = 10mA$, 1kHz	70		dB
			$I_{OUT} = 100mA$, 10kHz	62		

AT6211C25 ($V_{IN} = V_{OUT} + 1V$, $V_{CE} = V_{IN}$, $C_{IN} = C_L = 1\mu F$, $T_a = 25^\circ C$, unless otherwise noted)

Parameter	Symbol	Conditions	Min.	Typ.	Max.	Units
Output Voltage	$V_{OUT(E)}$ (Note 2)	$I_{OUT} = 30mA$, $V_{IN} = V_{OUT} + 1V$	X 0.99	$V_{OUT(T)}$ (Note 1)	X1.01	V
Maximum Output Current	I_{OUTMAX}	$V_{IN} = V_{OUT} + 1V$		400		mA
Load Regulation	ΔV_{OUT}	$V_{IN} = V_{OUT} + 1V$, $1mA \leq I_{OUT} \leq 100mA$		9		mV
Dropout Voltage (Note 3)	V_{DIF1}	$I_{OUT} = 100mA$		110		mV
	V_{DIF2}	$I_{OUT} = 200mA$		220		mV
Supply Current	I_{SS}	$V_{IN} = V_{OUT} + 1V$		30	60	μA
Stand-by Current	I_{CEL}	$V_{CE} = 0V$		0.1	1.0	μA
Line Regulation	$\frac{\Delta V_{OUT}}{\Delta V_{IN} \cdot V_{OUT}}$	$I_{OUT} = 30mA$, $V_{OUT} + 1V$ $\leq V_{IN} \leq 6.5V$		0.04		%/V
CE "High" Voltage	VCEH	Start up	1.0			V
CE "Low" Voltage	VCEL	Shut down			0.5	V
Output noise	EN	$I_{OUT} = 40mA$, 300Hz~50kHz		50		μV_{rms}
Ripple Rejection Rate	PSRR	$V_{IN} = [V_{OUT} + 1]V$ $+1V_{p-pAC}$	$I_{OUT} = 10mA$, 1kHz	70		dB
			$I_{OUT} = 100mA$, 10kHz	62		
			$I_{OUT} = 200mA$, 10kHz	62		
Short-circuit Current	I_{SHORT}	$V_{IN} = V_{OUT} + 1V$, $V_{CE} = V_{IN}$, $V_{OUT} = 0V$		60		mA

AT6211 Series

AT6211C28 ($V_{IN}=V_{OUT}+1V$, $V_{CE}=V_{IN}$, $C_{IN}=C_L=1\mu F$, $T_a=25^\circ C$, unless otherwise noted)

Parameter	Symbol	Conditions	Min.	Typ.	Max.	Units
Output Voltage	$V_{OUT(E)}$ (Note 2)	$I_{OUT}=30mA$, $V_{IN}=V_{OUT}+1V$	X 0.99	$V_{OUT(T)}$ (Note 1)	X1.01	V
Maximum Outputcurrent	I_{OUTMAX}	$V_{IN}=V_{OUT}+1V$		450		mA
Load Regulation	ΔV_{OUT}	$V_{IN}=V_{OUT}+1V$, $1mA \leq I_{OUT} \leq 100mA$		7		mV
Dropout Voltage (Note 3)	V_{DIF1}	$I_{OUT}=100mA$		110		mV
	V_{DIF2}	$I_{OUT}=200mA$		220		mV
Supply Current	I_{SS}	$V_{IN}=V_{OUT}+1V$		30	60	μA
Stand-by Current	I_{CEL}	$V_{CE}=0V$		0.1	1.0	μA
Line Regulation	$\frac{\Delta V_{OUT}}{\Delta V_{IN} \cdot V_{OUT}}$	$I_{OUT}=30mA$ $V_{OUT}+1V$ $\leq V_{IN} \leq 6.5V$		0.04		%/V
CE "High" Voltage	V_{CEH}	Start up	1.0			V
CE "Low" Voltage	V_{CEL}	Shut down			0.5	V
Output noise	EN	$I_{OUT}=40mA$, 300Hz~50kHz		50		μV_{rms}
Ripple Rejection Rate	PSRR	$V_{IN}=[V_{OUT}+1]V+$ $1V_{p-pAC}$	$I_{OUT}=10mA, 1kHz$	70		dB
			$I_{OUT}=100mA, 10kHz$	62		
			$I_{OUT}=200mA, 10kHz$	62		
Short-circuit Current	I_{SHORT}	$V_{IN}=V_{OUT}+1V$, $V_{CE}=V_{IN}$, $V_{OUT}=0V$		65		mA

AT6211C30 ($V_{IN}=V_{OUT}+1V$, $V_{CE}=V_{IN}$, $C_{IN}=C_L=1\mu F$, $T_a=25^\circ C$, unless otherwise noted)

Parameter	Symbol	Conditions	Min.	Typ.	Max.	Units
Output Voltage	$V_{OUT(E)}$ (Note 2)	$I_{OUT}=30mA$, $V_{IN}=V_{OUT}+1V$	X 0.99	$V_{OUT(T)}$ (Note 1)	X 1.01	V
Maximum Output Current	I_{OUTMAX}	$V_{IN}=V_{OUT}+1V$		500		mA
Load Regulation	ΔV_{OUT}	$V_{IN}=V_{OUT}+1V$, $1mA \leq I_{OUT} \leq 100mA$		8		mV
Dropout Voltage (Note 3)	V_{DIF1}	$I_{OUT}=100mA$		100		mV
	V_{DIF2}	$I_{OUT}=200mA$		210		mV
Supply Current	I_{SS}	$V_{IN}=V_{OUT}+1V$		30	60	μA
Stand-by Current	I_{CEL}	$V_{CE}=0V$		0.1	1.0	μA
Line Regulation	$\frac{\Delta V_{OUT}}{\Delta V_{IN} \cdot V_{OUT}}$	$I_{OUT}=30mA$ $V_{OUT}+1V \leq V_{IN} \leq 6.5V$		0.05		%/V
CE "High" Voltage	V_{CEH}	Start up	1.0			V
CE "Low" Voltage	V_{CEL}	Shut down			0.5	V
Output noise	EN	$I_{OUT}=40mA$, 300Hz~50kHz		50		μV_{rms}
Ripple Rejection Rate	PSRR	$V_{IN}=[V_{OUT}+1]V+$ $+1V_{p-pAC}$	$I_{OUT}=10mA, 1kHz$	70		dB
			$I_{OUT}=100mA, 10kHz$	62		
			$I_{OUT}=200mA, 10kHz$	62		
Short-circuit Current	I_{SHORT}	$V_{IN}=V_{OUT}+1V$, $V_{CE}=V_{IN}$, $V_{OU}=0V$		65		mA

AT6211 Series

AT6211C33 ($V_{IN}=V_{OUT}+1V$, $V_{CE}=V_{IN}$, $C_{IN}=C_L=1\mu F$, $T_a=25^\circ C$, unless otherwise noted)

Parameter	Symbol	Conditions	Min.	Typ.	Max.	Units
Output Voltage	$V_{OUT(E)}$ (Note 2)	$I_{OUT}=30mA$, $V_{IN}=V_{OUT}+1V$	X 0.99	$V_{OUT(T)}$ (Note 1)	X 1.01	V
Maximum Output Current	I_{OUTMAX}	$V_{IN}=V_{OUT}+1V$		500		mA
Load Regulation	ΔV_{OUT}	$V_{IN}=V_{OUT}+1V$, $1mA \leq I_{OUT} \leq 100mA$		9		mV
Dropout Voltage (Note 3)	V_{DIF1}	$I_{OUT}=100mA$		120		mV
	V_{DIF2}	$I_{OUT}=200mA$		260		mV
Supply Current	I_{SS}	$V_{IN}=V_{OUT}+1V$		30	60	μA
Stand-byCurrent	I_{CEL}	$V_{CE}=0V$		0.1	1.0	μA
Line Regulation	$\frac{\Delta V_{OUT}}{\Delta V_{IN} \cdot V_{OUT}}$	$I_{OUT}=30mA$ $V_{OUT}+1V \leq V_{IN} \leq 6.5V$		0.05		%/V
CE "High" Voltage	VCEH	Start up	1.0			V
CE "Low" Voltage	VCEL	Shut down			0.5	V
Output noise	EN	$I_{OUT}=40mA$, 300Hz~50kHz		50		μV_{rms}
Ripple Rejection Rate	PSRR	$V_{IN} = [V_{OUT} + 1]V$ $+1Vp-pAC$	$I_{OUT}=10mA, 1kHz$	70		dB
			$I_{OUT}=100mA, 10kHz$	62		
			$I_{OUT}=200mA, 10kHz$	62		
Short-circuit Current	I_{SHORT}	$V_{IN}=V_{OUT}+1V$, $V_{CE}=V_{IN}$, $V_{OUT}=0V$		70		mA

AT6211C33 (SOT343R, FBP1*1-4L, SOT353)

($V_{IN}=V_{OUT}+1V$, $V_{CE}=V_{IN}$, $C_{IN}=C_L=1\mu F$, $T_a=25^\circ C$, unless otherwise noted)

Parameter	Symbol	Conditions	Min.	Typ.	Max.	Units
Output Voltage	$V_{OUT(E)}$ (Note 2)	$I_{OUT}=30mA$, $V_{IN}=V_{OUT}+1V$	X 0.99	$V_{OUT(T)}$ (Note 1)	X 1.01	V
Maximum Output Current	I_{OUTMAX}	$V_{IN}=V_{OUT}+1V$		400		mA
Load Regulation	ΔV_{OUT}	$V_{IN}=V_{OUT}+1V$, $1mA \leq I_{OUT} \leq 100mA$		9		mV
Dropout Voltage (Note 3)	V_{DIF1}	$I_{OUT}=100mA$		120		mV
	V_{DIF2}	$I_{OUT}=200mA$		260		mV
Supply Current	I_{SS}	$V_{IN}=V_{OUT}+1V$		30	60	μA
Stand-byCurrent	I_{CEL}	$V_{CE}=0V$		0.1	1.0	μA
Line Regulation	$\frac{\Delta V_{OUT}}{\Delta V_{IN} \cdot V_{OUT}}$	$I_{OUT}=30mA$ $V_{OUT}+1V \leq V_{IN} \leq 6.5V$		0.05		%/V
CE "High" Voltage	VCEH	Start up	1.0			V
CE "Low" Voltage	VCEL	Shut down			0.5	V
Output noise	EN	$I_{OUT}=40mA$, 300Hz~50kHz		50		μV_{rms}
Ripple Rejection Rate	PSRR	$V_{IN} = [V_{OUT} + 1]V$ $+1Vp-pAC$	$I_{OUT}=10mA, 1kHz$	70		dB
			$I_{OUT}=100mA, 10kHz$	62		
			$I_{OUT}=200mA, 10kHz$	62		
Short-circuit Current	I_{SHORT}	$V_{IN}=V_{OUT}+1V$, $V_{CE}=V_{IN}$, $V_{OUT}=0V$		70		mA

AT6211 Series

AT6211C36 ($V_{IN}=V_{OUT}+1V, V_{CE}=V_{IN}, C_{IN}=C_L=1\mu F, T_a=25^\circ C$, unless otherwise noted)

Parameter	Symbol	Conditions	Min.	Typ	Max.	Units
Output Voltage	$V_{OUT(E)}$ (Note 2)	$I_{OUT}=30mA,$ $V_{IN}=V_{OUT}+1V$	X 0.99	$V_{OUT(T)}$ (Note 1)	X1.01	V
Maximum Output Current	I_{OUTMAX}	$V_{IN}=V_{OUT}+1V$		400		mA
Load Regulation	ΔV_{OUT}	$V_{IN}=V_{OUT}+1V,$ $1mA \leq I_{OUT} \leq 100mA$		8		mV
Dropout Voltage (Note 3)	V_{DIF1}	$I_{OUT}=100mA$		100		mV
	V_{DIF2}	$I_{OUT}=200mA$		200		mV
Supply Current	I_{SS}	$V_{IN}=V_{OUT}+1V$		40	60	μA
Stand-by Current	I_{CEL}	$V_{CE}=0V$		0.1	1.0	μA
Line Regulation	$\frac{\Delta V_{OUT}}{\Delta V_{IN} \cdot V_{OUT}}$	$I_{OUT}=30mA$ $V_{OUT}+1V \leq V_{IN} \leq 6.5V$		0.05		%/V
CE "High" Voltage	VCEH	Start up	1.0			V
CE "Low" Voltage	VCEL	Shut down			0.5	V
Output noise	EN	$I_{OUT}=40mA, 300Hz \sim 50kHz$		50		μV_{rms}
Ripple Rejection Rate	PSRR	$V_{IN} = [V_{OUT} + 1]V$ $+1V_{p-pAC}$	$I_{OUT}=10mA, 1kHz$	70		dB
			$I_{OUT}=100mA, 10kHz$	62		
			$I_{OUT}=200mA, 10kHz$	62		
Short-circuit Current	I_{SHORT}	$V_{IN}=V_{OUT}+1V, V_{CE}=V_{IN}, V_{OUT}=0V$		100		mA

AT6211C50 ($V_{IN}=V_{OUT}+1V, V_{CE}=V_{IN}, C_{IN}=C_L=1\mu F, T_a=25^\circ C$, unless otherwise noted)

Parameter	Symbol	Conditions	Min.	Typ.	Max.	Units
Output Voltage	$V_{OUT(E)}$ (Note 2)	$I_{OUT}=30mA,$ $V_{IN}=V_{OUT}+1V$	X 0.99	$V_{OUT(T)}$ (Note 1)	X 1.01	V
Maximum Output Current	I_{OUTMAX}	$V_{IN}=V_{OUT}+1V$		500		mA
Load Regulation	ΔV_{OUT}	$V_{IN}=V_{OUT}+1V,$ $1mA \leq I_{OUT} \leq 100mA$		8		mV
Dropout Voltage (Note 3)	V_{DIF1}	$I_{OUT}=100mA$		100		mV
	V_{DIF2}	$I_{OUT}=200mA$		200		mV
Supply Current	I_{SS}	$V_{IN}=V_{OUT}+1V$		40	60	μA
Stand-by Current	I_{CEL}	$V_{CE}=0V$		0.1	1.0	μA
Line Regulation	$\frac{\Delta V_{OUT}}{\Delta V_{IN} \cdot V_{OUT}}$	$I_{OUT}=30mA$ $V_{OUT}+1V \leq V_{IN} \leq 6.5V$		0.05		%/V
CE "High" Voltage	VCEH	Start up	1.0			V
CE "Low" Voltage	VCEL	Shut down			0.7	V
Output noise	EN	$I_{OUT}=40mA, 300Hz \sim 50kHz$		50		μV_{rms}
Ripple Rejection Rate	PSRR	$V_{IN} = [V_{OUT} + 1]V$ $+1V_{p-pAC}$	$I_{OUT}=10mA, 1kHz$	70		dB
			$I_{OUT}=100mA, 10kHz$	62		
			$I_{OUT}=200mA, 10kHz$	62		
Short-circuit Current	I_{SHORT}	$V_{IN}=V_{OUT}+1V, V_{CE}=V_{IN}, V_{OUT}=0V$		100		mA

AT6211 Series

AT6211A30 ($V_{IN}=V_{OUT}+1V$, $C_{IN}=C_L=1\mu F$, $T_a=25^\circ C$, unless otherwise noted)

Parameter	Symbol	Conditions	Min.	Typ.	Max.	Units
Output Voltage	$V_{OUT(E)}$ (Note 2)	$I_{OUT}=30mA$, $V_{IN}=V_{OUT}+1V$	X 0.99	$V_{OUT(T)}$ (Note 1)	X 1.01	V
Maximum Output Current	I_{OUTMAX}	$V_{IN}=V_{OUT}+1V$		500		mA
Load Regulation	ΔV_{OUT}	$V_{IN}=V_{OUT}+1V$, $1mA \leq I_{OUT} \leq 100mA$		8		mV
Dropout Voltage (Note 3)	V_{DIF1}	$I_{OUT}=100mA$		100		mV
	V_{DIF2}	$I_{OUT}=200mA$		210		mV
Supply Current	I_{SS}	$V_{IN}=V_{OUT}+1V$		30	60	μA
Line Regulation	$\frac{\Delta V_{OUT}}{\Delta V_{IN} \cdot V_{OUT}}$	$I_{OUT}=30mA$ $V_{OUT}+1V \leq V_{IN} \leq 6.5V$		0.05		%/V
Output noise	EN	$I_{OUT}=40mA$, 300Hz~50kHz		50		μV_{rms}
Ripple Rejection Rate	PSRR	$V_{IN}=[V_{OUT}+1]V$ $+1Vp-pAC$	$I_{OUT}=10mA, 1kHz$	70		dB
			$I_{OUT}=100mA, 10kHz$	62		
			$I_{OUT}=200mA, 10kHz$	62		
Short-circuit Current	I_{SHORT}	$V_{IN}=V_{OUT}+1V$, $V_{CE}=V_{IN}$, $V_{OUT}=0V$		65		mA

AT6211A33 ($V_{IN}=V_{OUT}+1V$, $C_{IN}=C_L=1\mu F$, $T_a=25^\circ C$, unless otherwise noted)

Parameter	Symbol	Conditions	Min.	Typ.	Max.	Units
Output Voltage	$V_{OUT(E)}$ (Note 2)	$I_{OUT}=30mA$, $V_{IN}=V_{OUT}+1V$	X 0.99	$V_{OUT(T)}$ (Note 1)	X 1.01	V
Maximum Output Current	I_{OUTMAX}	$V_{IN}=V_{OUT}+1V$		500		mA
Load Regulation	ΔV_{OUT}	$V_{IN}=V_{OUT}+1V$, $1mA \leq I_{OUT} \leq 100mA$		9		mV
Dropout Voltage (Note 3)	V_{DIF1}	$I_{OUT}=100mA$		120		mV
	V_{DIF2}	$I_{OUT}=200mA$		260		mV
Supply Current	I_{SS}	$V_{IN}=V_{OUT}+1V$		30	60	μA
Line Regulation	$\frac{\Delta V_{OUT}}{\Delta V_{IN} \cdot V_{OUT}}$	$I_{OUT}=30mA$ $V_{OUT}+1V \leq V_{IN} \leq 6.5V$		0.1	1.0	%/V
Output noise	EN	$I_{OUT}=40mA$, 300Hz~50kHz		50		μV_{rms}
Ripple Rejection Rate	PSRR	$V_{IN}=[V_{OUT}+1]V$ $+1Vp-pAC$	$I_{OUT}=10mA, 1kHz$	70		dB
			$I_{OUT}=100mA, 10kHz$	62		
			$I_{OUT}=200mA, 10kHz$	62		
Short-circuit Current	I_{SHORT}	$V_{IN}=V_{OUT}+1V$, $V_{OUT}=0V$		70		mA

AT6211 Series

AT6211A25 ($V_{IN}=V_{OUT}+1V$, $C_{IN}=C_L=1\mu F$, $T_a=25^\circ C$, unless otherwise noted)

Parameter	Symbol	Conditions	Min.	Typ.	Max.	Units
Output Voltage	$V_{OUT(E)}$ (Note 2)	$I_{OUT}=30mA$, $V_{IN}=V_{OUT}+1V$	X 0.99	$V_{OUT(T)}$ (Note 1)	X 1.01	V
Maximum Output current	I_{OUTMAX}	$V_{IN}=V_{OUT}+1V$		400		mA
Load Regulation	ΔV_{OUT}	$V_{IN}=V_{OUT}+1V$, $1mA \leq I_{OUT} \leq 100mA$		9		mV
Dropout Voltage (Note 3)	V_{DIF1}	$I_{OUT}=100mA$		80		mV
	V_{DIF2}	$I_{OUT}=200mA$		180		mV
Supply Current	I_{SS}	$V_{IN}=V_{OUT}+1V$		30	60	μA
Line Regulation	$\frac{\Delta V_{OUT}}{\Delta V_{IN} \cdot V_{OUT}}$	$I_{OUT}=30mA$ $V_{OUT}+1V \leq V_{IN} \leq 6.5V$		0.1	1.0	%/V
Output noise	EN	$I_{OUT}=40mA$, 300Hz~50kHz		50		μV_{rms}
Ripple Rejection Rate	PSRR	$V_{IN}=[V_{OUT}+1]V$ $+1Vp-pAC$	$I_{OUT}=10mA, 1kHz$	70		dB
			$I_{OUT}=100mA, 10kHz$	62		
			$I_{OUT}=200mA, 10kHz$	62		
Short-circuit Current	I_{SHORT}	$V_{IN}=V_{OUT}+1V$, $V_{OUT}=0V$		60		mA

AT6211H15 ($V_{IN}=V_{OUT}+1V$, $V_{CE}=GND$, $C_{IN}=C_L=1\mu F$, $T_a=25^\circ C$, unless otherwise noted)

Parameter	Symbol	Conditions	Min.	Typ.	Max.	Units
Output Voltage	$V_{OUT(E)}$ (Note 2)	$I_{OUT}=30mA$, $V_{IN}=V_{OUT}+1V$	X 0.98	$V_{OUT(T)}$ (Note 1)	X 1.02	V
Maximum Output Current	I_{OUTMAX}	$V_{IN}=V_{OUT}+1V$		300		mA
Load Regulation	ΔV_{OUT}	$V_{IN}=V_{OUT}+1V$, $1mA \leq I_{OUT} \leq 100mA$		9		mV
Dropout Voltage (Note 3)	V_{DIF1}	$I_{OUT}=100mA$		200		mV
	V_{DIF2}	$I_{OUT}=200mA$		400		mV
Supply Current	I_{SS}	$V_{IN}=V_{OUT}+1V$		30	60	μA
Stand-by Current	I_{CEL}	$V_{CE}=V_{IN}$		0.1	1.0	μA
Line Regulation	$\frac{\Delta V_{OUT}}{\Delta V_{IN} \cdot V_{OUT}}$	$I_{OUT}=30mA$ $V_{OUT}+1V \leq V_{IN} \leq 6.5V$		0.05		%/V
CE "High" Voltage	VCEH	Shut down	1.0			V
CE "Low" Voltage	VCEL	Start up			0.4	V
Output noise	EN	$I_{OUT}=40mA$, 300Hz~50kHz		50		μV_{rms}
Ripple Rejection Rate	PSRR	$V_{IN}=[V_{OUT}+1]V+1Vp-pAC$		$I_{OUT}=10mA, 1kHz$	70	dB

Note: 1. $V_{OUT(T)}$: Specified Output Voltage

2. $V_{OUT(E)}$: Effective Output Voltage (i.e. The output voltage when " $V_{OUT(T)}+1.0V$ " is provided at the Vin pin while maintaining a certain I_{OUT} value.)

3. V_{DIF} : $V_{IN1}-V_{OUT(E)}$

V_{IN1} : The input voltage when $V_{OUT(E)}$ appears as input voltage is gradually decreased.

$V_{OUT(E)}$: A voltage equal to 98% of the output voltage whenever an amply stabilized $I_{OUT}\{V_{OUT(T)}+1.0V\}$ is input.

AT6211 Series

Typical Characteristics

(1) Output Current VS. Output Voltage ($V_{IN}=V_{out}+1$, $T_a = 25^\circ\text{C}$)

AT6211C33SEG

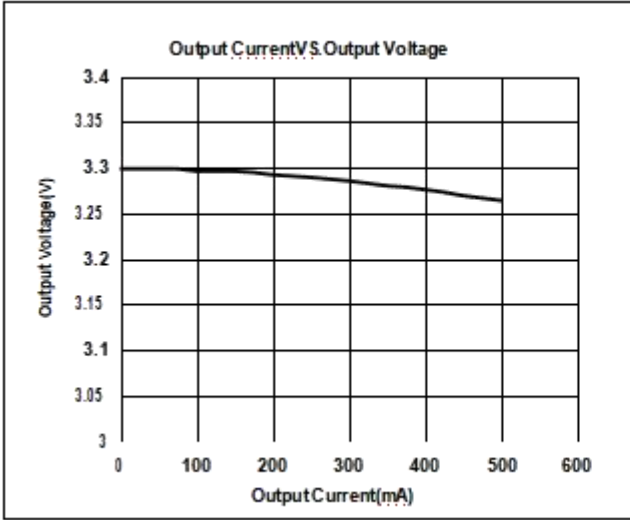

AT6211C30SEG

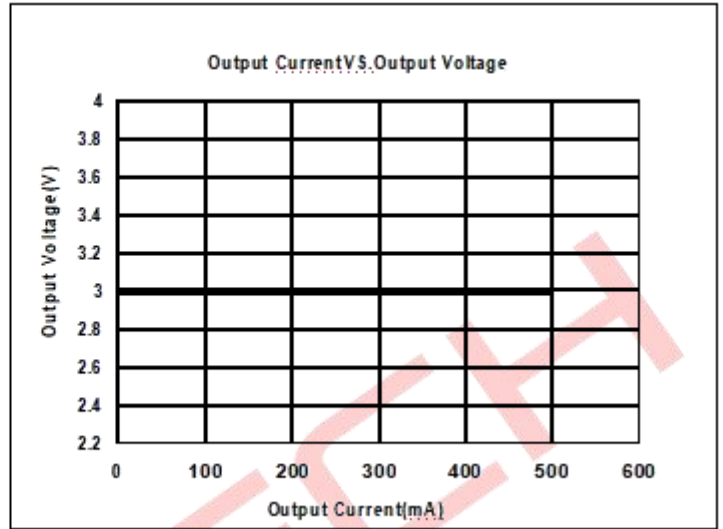

AT6211C28SEG

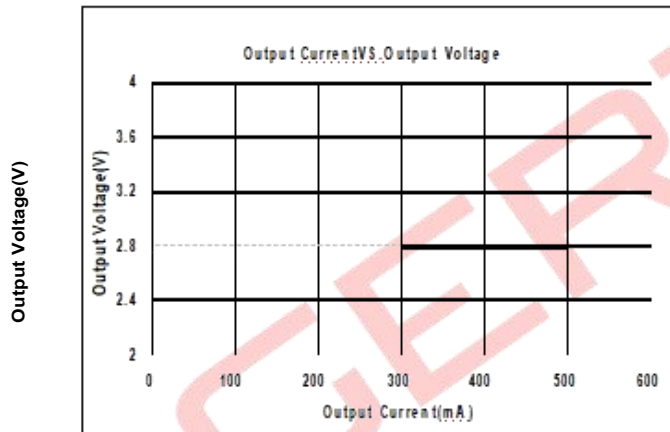

AT6211C18SEG

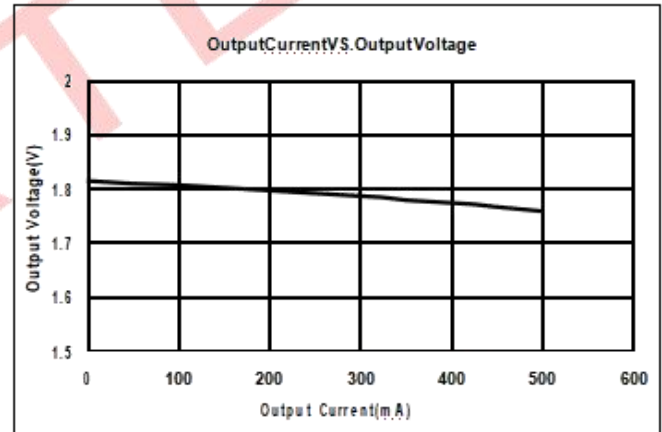

(2) Input Voltage VS. Output Voltage ($T_a = 25^\circ\text{C}$)

AT6211C33SEG

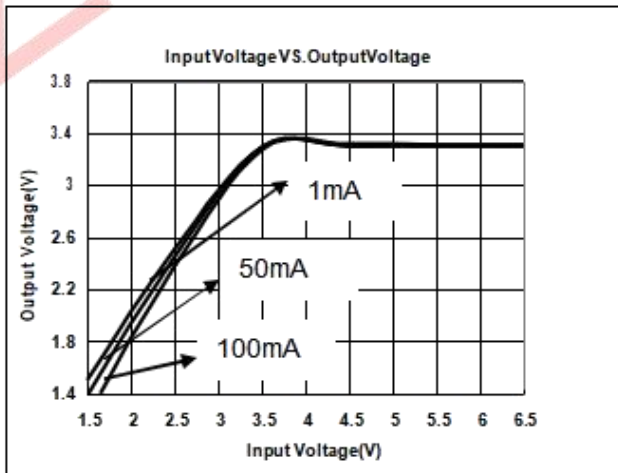

AT6211C30SEG

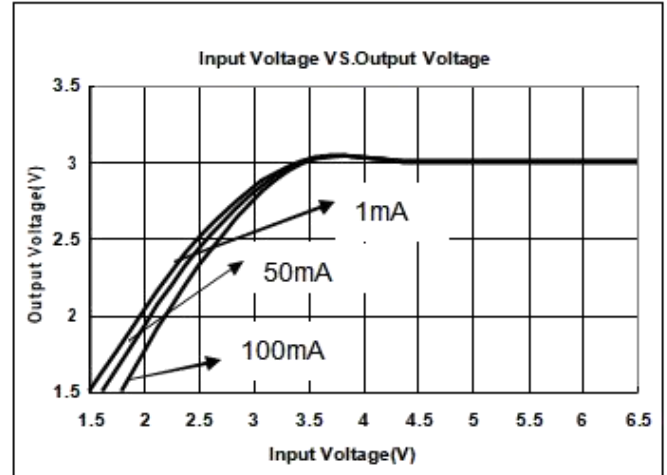

AT6211 Series

AT6211C28SEG

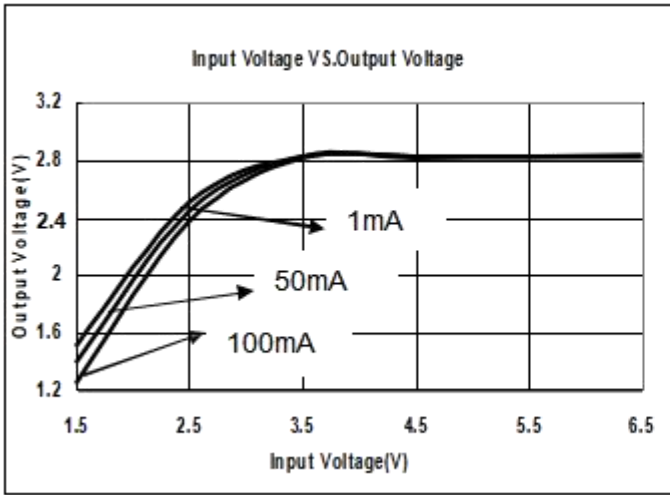

AT6211C18SEG

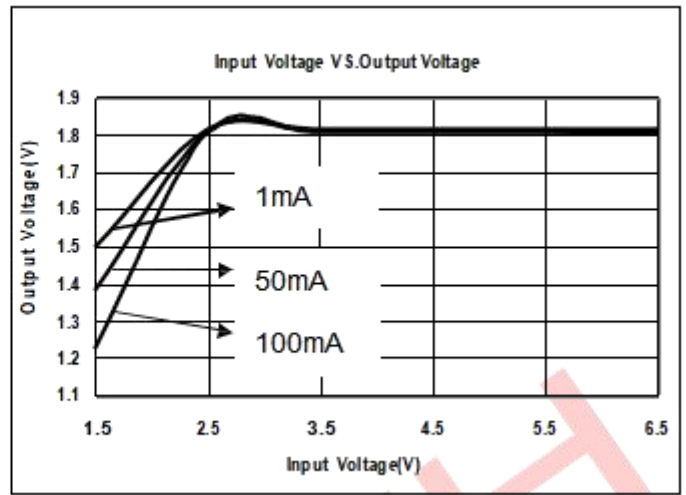

(3) Output Current VS. Dropout Voltage ($V_{IN}=V_{out}+1V, T_a = 25^\circ C$)

AT6211C33SEG

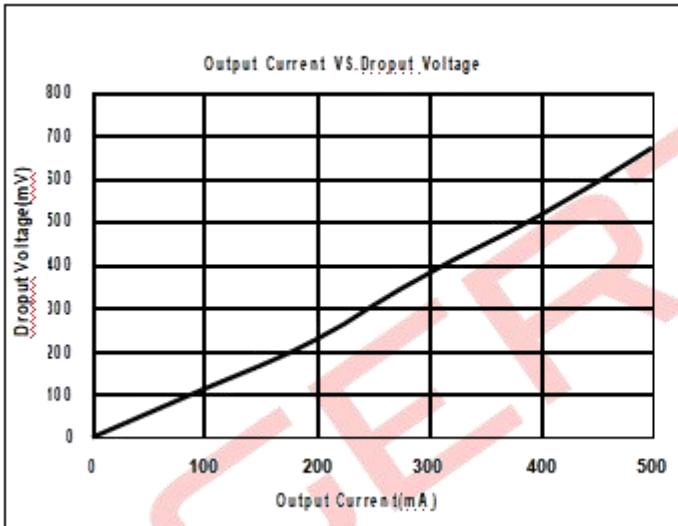

AT6211C30SEG

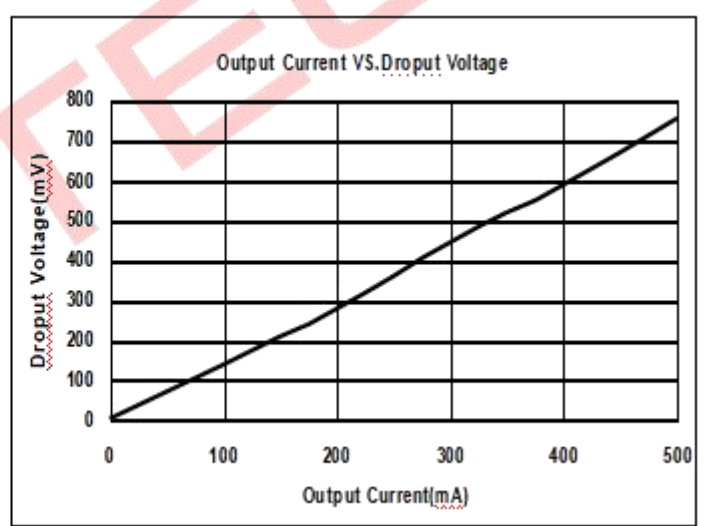

AT6211C28SEG

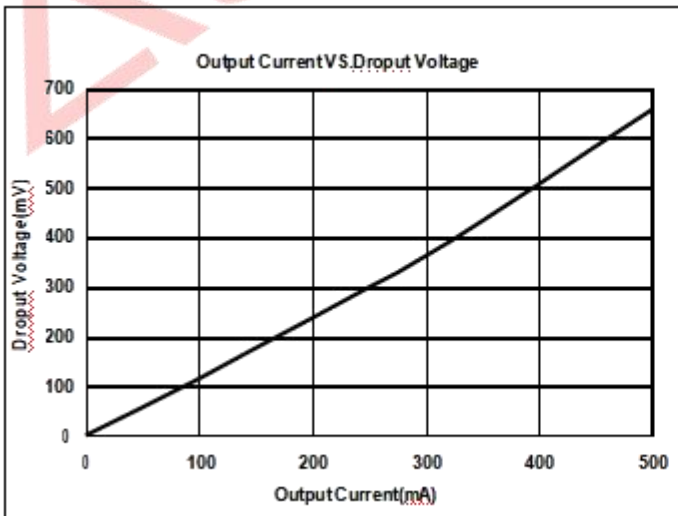

AT6211C18SEG

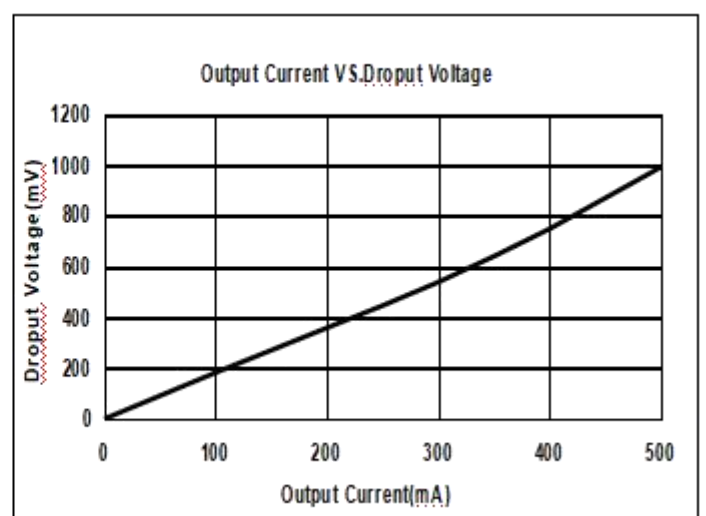

AT6211 Series

(4) Input Voltage VS. Supply Current ($T_a = 25^\circ\text{C}$)

AT6211C33SEG

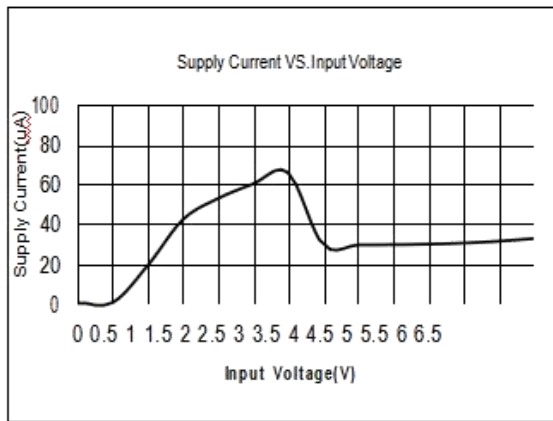

AT6211C30SEG

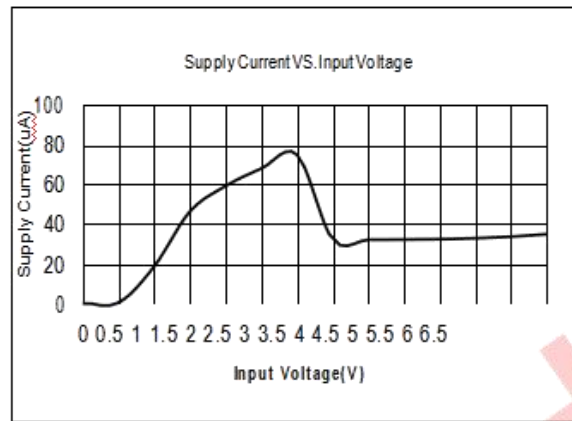

AT6211C28SEG

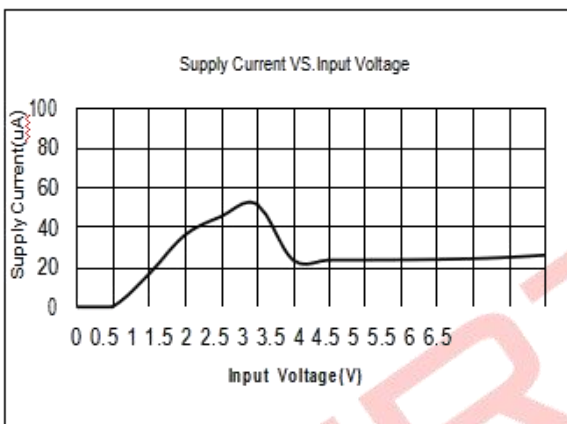

AT6211C18SEG

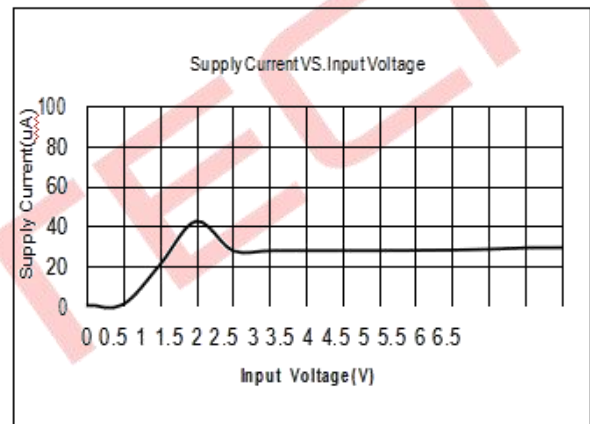

(5) PSRR

AT6211C18SEG

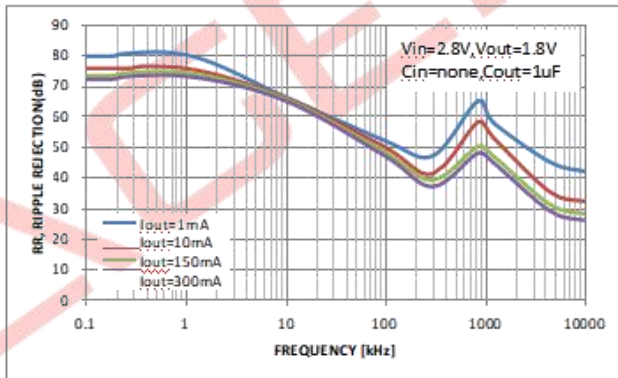

AT6211C28SEG

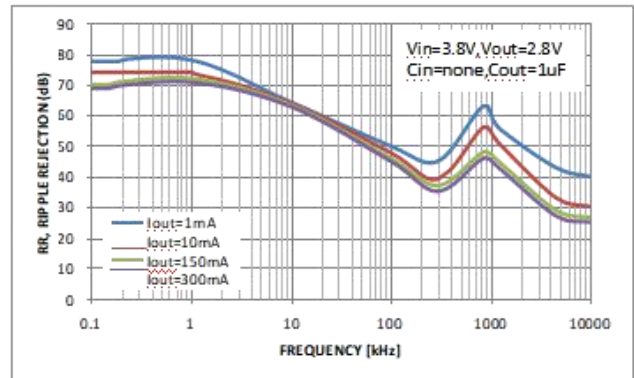

(6) Temperature vs. Output Voltage

AT6211C25

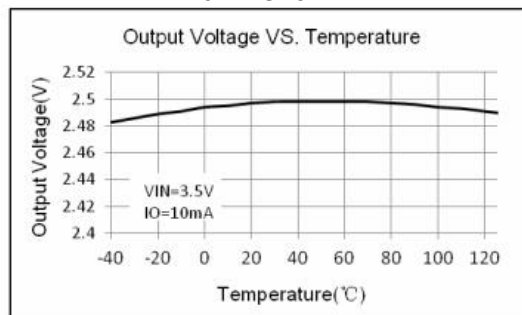

AT6211 Series

Packaging Information

- Package Type: SOT23-3

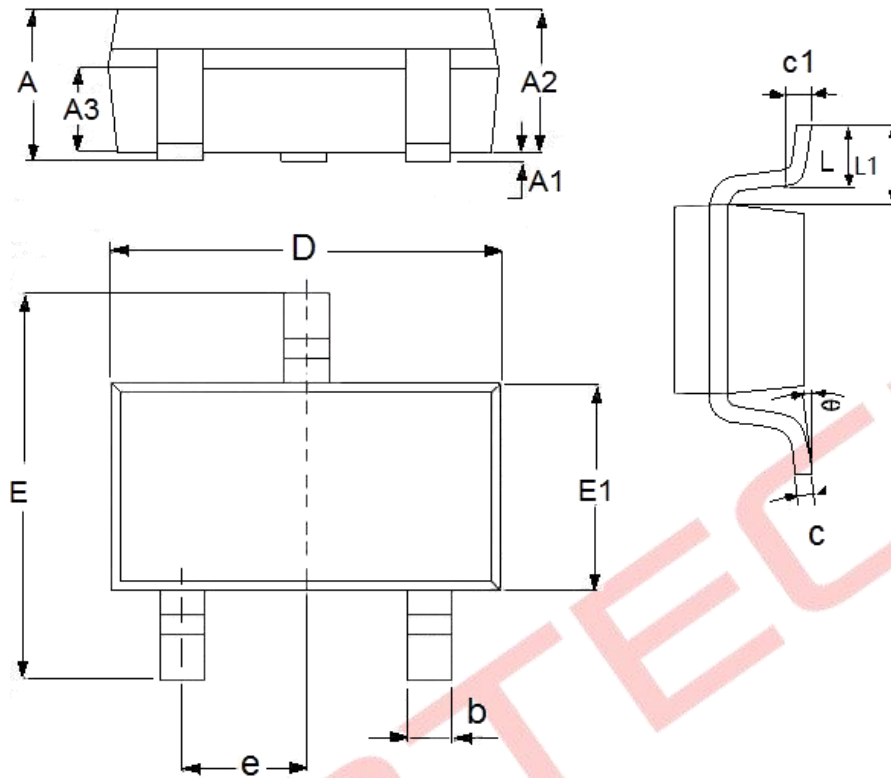

DIM	Millimeters		Inches	
	Min	Max	Min	Max
A	1.05	1.45	0.0413	0.0571
A1	0	0.15	0.0000	0.0059
A2	0.9	1.3	0.0354	0.0512
A3	0.6	0.7	0.0236	0.0276
b	0.25	0.5	0.0098	0.0197
c	0.1	0.25	0.0039	0.0098
D	2.8	3.1	0.1102	0.1220
E	2.6	3.1	0.1023	0.1220
E1	1.5	1.8	0.0591	0.0709
e	0.95(TYP)		0.0374(TYP)	
L	0.25	0.6	0.0098	0.0236
L1	0.59(TYP)		0.0232(TYP)	
θ	0	8°	0.0000	8°
c1	0.2(TYP)		0.0079(TYP)	

AT6211 Series

- Package Type: SOT89-3

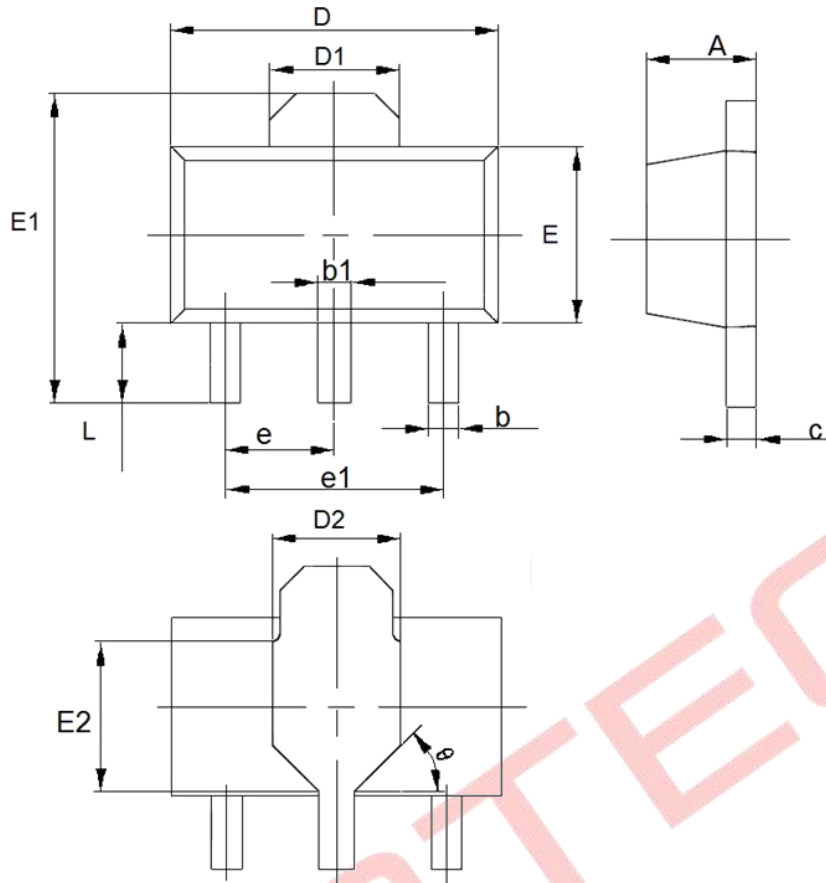

DIM	Millimeters		Inches	
	Min	Max	Min	Max
A	1.4	1.6	0.0551	0.063
b	0.32	0.52	0.0126	0.0205
b1	0.4	0.58	0.0157	0.0228
c	0.35	0.45	0.0138	0.01772
D	4.4	4.6	0.1732	0.1811
D1	1.55(TYP)		0.061(TYP)	
D2	1.75(TYP)		0.0689(TYP)	
e1	3(TYP)		0.1181(TYP)	
E	2.3	2.6	0.0906	0.1023
E1	3.94	4.4	0.1551	0.1732
E2	1.9(TYP)		0.0748(TYP)	
e	1.5(TYP)		0.0591(TYP)	
L	0.8	1.2	0.0315	0.0472
θ	45°		45°	

AT6211 Series

- Package Type: SOT23-5

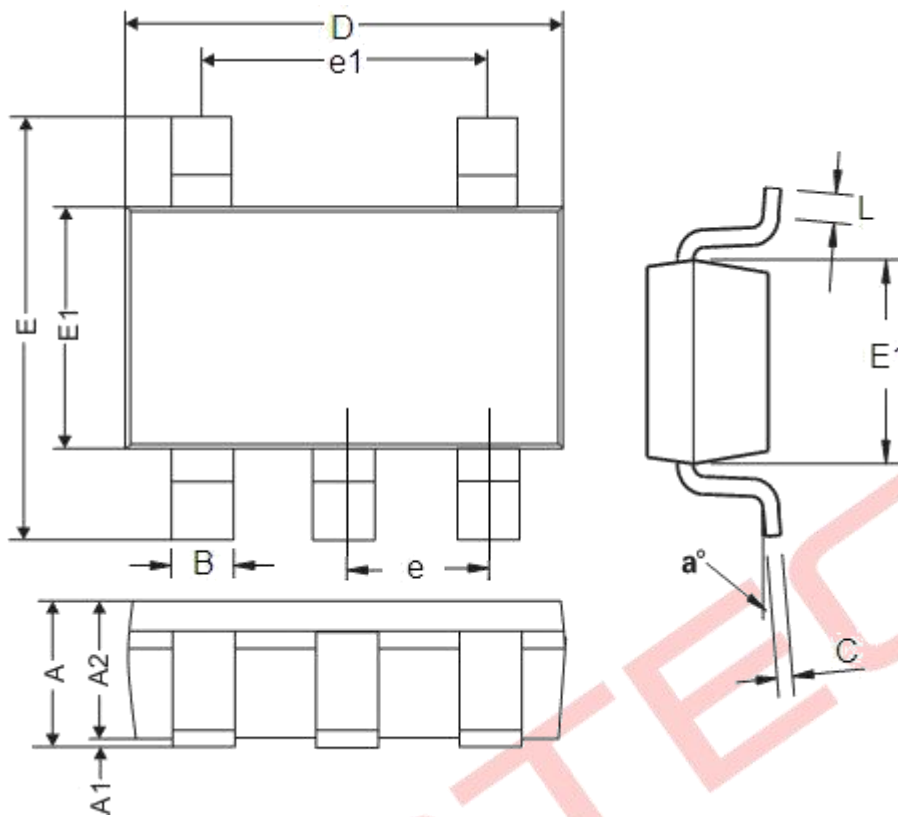

DIM	Millimeters		Inches	
	Min	Max	Min	Max
A	1.05	1.45	0.0413	0.0570
A1	0	0.15	0	0.0059
A2	0.9	1.3	0.0354	0.0511
B	0.25	0.5	0.0098	0.0196
C	0.10	0.23	0.0039	0.0090
D	2.82	3.05	0.1110	0.1200
E	2.60	3.05	0.1023	0.1200
E1	1.50	1.75	0.0590	0.0688
e	0.95REF		0.0374REF	
e1	1.90REF		0.0748REF	
L	0.10	0.60	0.0039	0.0236
a°	0°	30°	0°	30°