

## 8 A - 800 V overvoltage protected AC switch

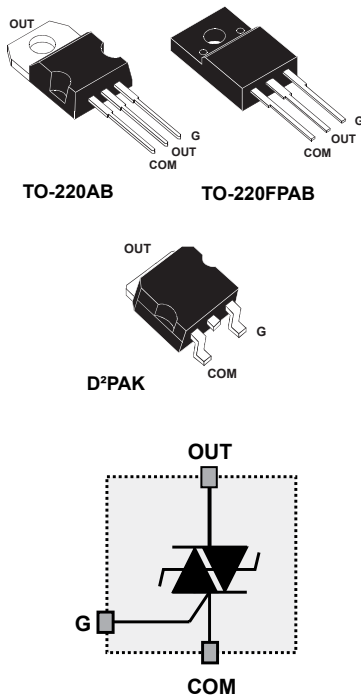

### Features

- Triac with overvoltage protection
- High noise immunity: static  $dV/dt > 2000 \text{ V}/\mu\text{s}$
- TO-220FPAB insulated package:
  - complies with UL standards (File ref : E81734)
  - insulation voltage:  $2000 \text{ V}_{\text{RMS}}$
- Benefits:
  - Enables equipment to meet IEC 61000-4-5
  - High off-state reliability with planar technology
  - Needs no external overvoltage protection
  - Reduces the power passive component count
  - High immunity against fast transients described in IEC 61000-4-4 standards

### Applications

- AC mains static switching in appliance and industrial control systems
- Drive of medium power AC loads such as:
  - Universal drum motor of washing machine
  - Compressor of fridge or air conditioner

### Description

The ACST8 series belongs to the ACS/ACST power switch family built around A.S.D. (application specific discrete) technology. This high performance device is suited to home appliances or industrial systems and drives an induction motor up to 8 A.

This ACST8 switch embeds a Triac structure with a high voltage clamping device to absorb the inductive turn-off energy and withstand line transients such as those described in the IEC 61000-4-5 standards.

ACST8 shows a high noise immunity complying with IEC standards such as IEC 61000-4-4 (fast transient burst test).

#### Product status link

ACST8

#### Product summary

$I_{\text{T(RMS)}}$	8 A
$V_{\text{DRM}}/V_{\text{RRM}}$	800 V
$I_{\text{GT}}$	30 mA

# 1 Characteristics

**Table 1. Absolute ratings (limiting values)**

Symbol	Parameter		Value	Unit	
$I_{T(RMS)}$	On-state rms current (full sine wave)	TO-220FPAB	$T_c = 91\text{ °C}$	8	A
		TO-220AB, D <sup>2</sup> PAK	$T_c = 105\text{ °C}$		
		D <sup>2</sup> PAK with 1 cm <sup>2</sup> copper	$T_{amb} = 43\text{ °C}$	2	
$I_{TSM}$	Non repetitive surge peak on-state current $T_j$ initial = 25 °C, (full cycle sine wave)	f = 50 Hz	$t_p = 20\text{ ms}$	80	A
		f = 60 Hz	$t_p = 16.7\text{ ms}$	84	
$I^2t$	$I^2t$ for fuse selection		$t_p = 10\text{ ms}$	42	A <sup>2</sup> s
$di/dt$	Critical rate of rise on-state current $I_G = 2 \times I_{GT}$ , $t_r \leq 100\text{ ns}$	f = 120 Hz	$T_j = 125\text{ °C}$	100	A/ $\mu$ s
$V_{PP}^{(1)}$	Non repetitive line peak pulse voltage		$T_j = 25\text{ °C}$	2	kV
$P_{G(AV)}$	Average gate power dissipation		$T_j = 125\text{ °C}$	0.1	W
$P_{GM}$	Peak gate power dissipation ( $t_p = 20\text{ ms}$ )		$T_j = 125\text{ °C}$	10	W
$I_{GM}$	Peak gate current ( $t_p = 20\text{ ms}$ )		$T_j = 125\text{ °C}$	1.6	A
$T_{stg}$	Storage temperature range			-40 to +150	°C
$T_j$	Operating junction temperature range			-40 to +125	°C
$T_L$	Lead temperature for soldering during 10 s (at 3 mm from plastic case)			260	°C
$V_{ins}$	Insulation rms voltage (60 seconds) for TO-220FPAB			2000	V

1. according to test described by standard IEC 61000-4-5 standard and Figure 17

**Table 2. Electrical characteristics per switch**

Symbol	Test conditions	Quadrant		Value	Unit
$I_{GT}^{(1)}$	$V_{OUT} = 12\text{ V}$ , $R_L = 33\ \Omega$	I - II - III	Max.	30	mA
$V_{GT}$			Max.	1.0	V
$V_{GD}$	$V_{OUT} = V_{DRM}$ , $R_L = 3.3\text{ k}\Omega$ , $T_j = 125\text{ °C}$	I - II - III	Min.	0.2	V
$I_H^{(2)}$	$I_{OUT} = 500\text{ mA}$		Max.	30	mA
$I_L$	$I_G = 1.2 \times I_{GT}$	I - II - III	Max.	50	mA
$dV/dt^{(2)}$	$V_{OUT} = 67\% V_{DRM}$ , gate open, $T_j = 125\text{ °C}$		Min.	2000	V/ $\mu$ s
$(di/dt)^c^{(2)}$	Without snubber, $T_j = 125\text{ °C}$		Min.	8	A/ms
$V_{CL}$	$I_{CL} = 0.1\text{ mA}$ , $t_p = 1\text{ ms}$		Min.	850	V

1. Minimum  $I_{GT}$  is guaranteed at 5% of  $I_{GT}$  max

2. For both polarities of OUT pin referenced to COM pin

**Table 3. Static characteristics**

Symbol	Test conditions		Value	Unit
$V_{TM}^{(1)}$	$I_{OUT} = 11.3 \text{ A}$ , $t_p = 500 \mu\text{s}$	$T_j = 25 \text{ }^\circ\text{C}$	Max. 1.5	V
$V_{T0}^{(1)}$	Threshold voltage	$T_j = 125 \text{ }^\circ\text{C}$	Max. 0.9	V
$R_D^{(1)}$	Dynamic resistance	$T_j = 125 \text{ }^\circ\text{C}$	Max. 50	m $\Omega$
$I_{DRM}$ $I_{RRM}$	$V_{OUT} = V_{DRM}/V_{RRM}$	$T_j = 25 \text{ }^\circ\text{C}$	Max. 20	$\mu\text{A}$
		$T_j = 125 \text{ }^\circ\text{C}$		1

1. For both polarities of OUT pin referenced to COM pin

**Table 4. Thermal characteristics**

Symbol	Parameter	Value	Unit
$R_{th(j-a)}$	Junction to ambient	TO-220FPAB, TO-220AB	60
	Junction to ambient (soldered on 1cm <sup>2</sup> copper pad)	D <sup>2</sup> PAK	45
$R_{th(j-c)}$	Junction to case (AC)	TO-220FPAB	3.6
		TO-220AB, D <sup>2</sup> PAK	2

## 1.1 Characteristics (curves)

**Figure 1. Maximum power dissipation versus RMS on-state current**

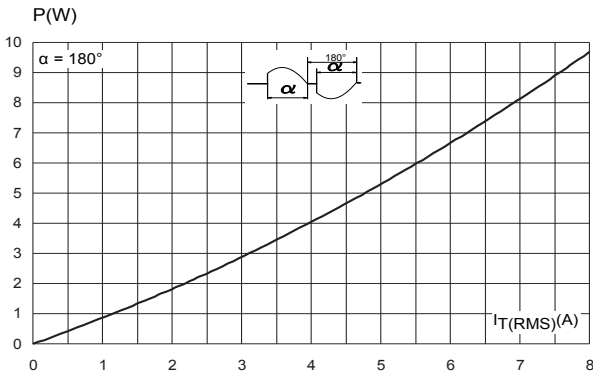

**Figure 2. On-state RMS current versus case temperature (full cycle)**

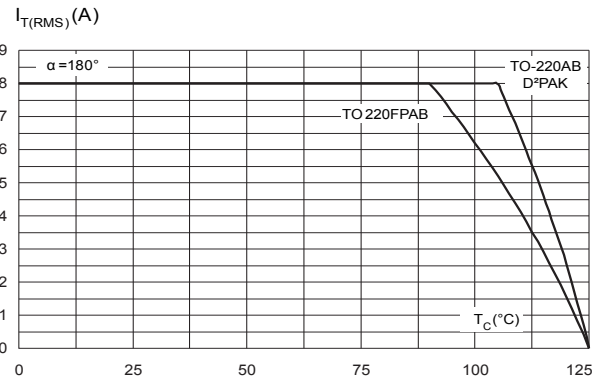

**Figure 3. On-state RMS current versus ambient temperature (free air convection, full cycle)**

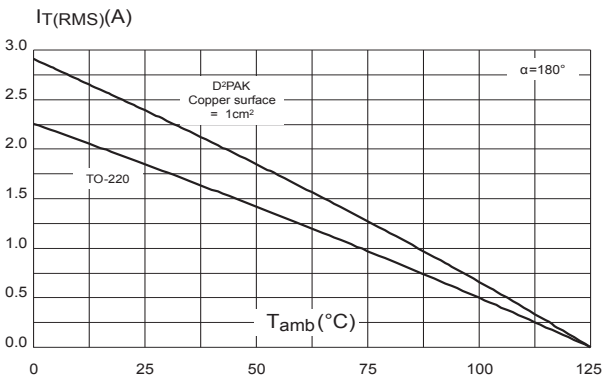

**Figure 4. Relative variation of thermal impedance versus pulse duration**

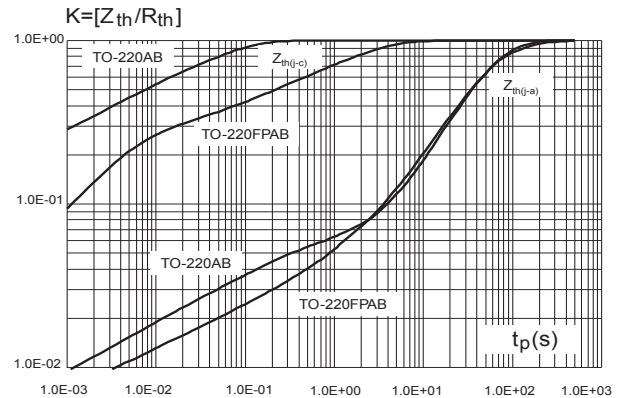

**Figure 5. Relative variation of gate trigger current and gate trigger voltage versus junction temperature (typical values)**

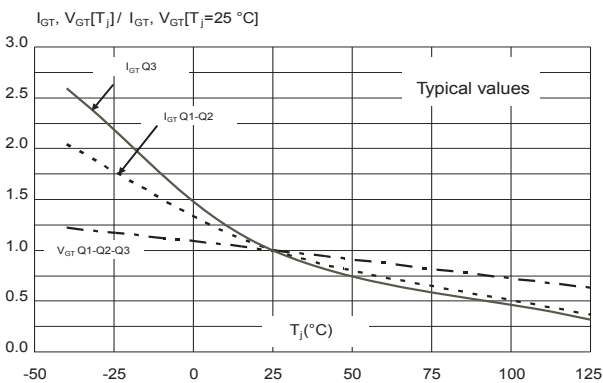

**Figure 6. Relative variation of holding current and latching current versus junction temperature (typical values)**

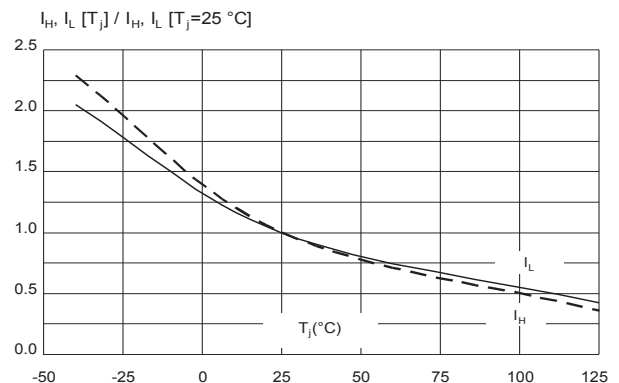

**Figure 7. Surge peak on-state current versus number of cycles**

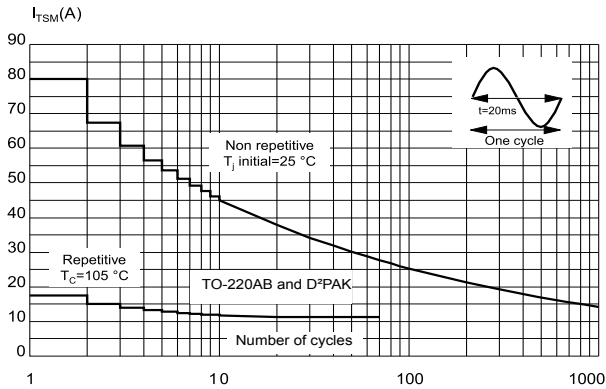

**Figure 8. Non repetitive surge peak on-state current for a sinusoidal pulse width**

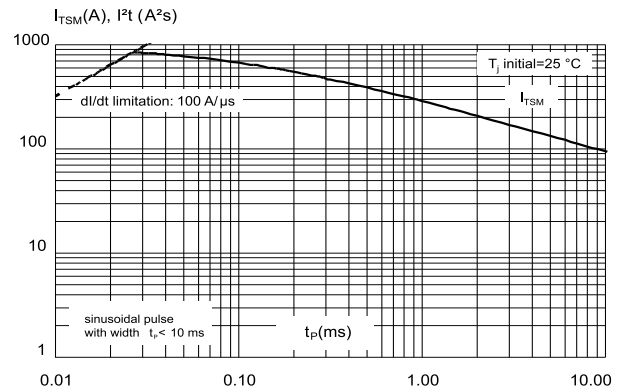

**Figure 9. On-state characteristics (maximum values)**

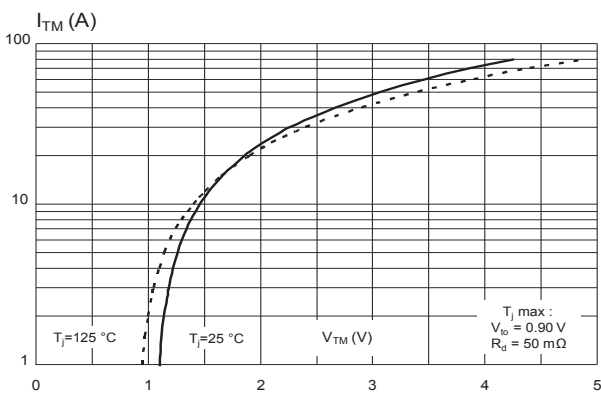

**Figure 10. Relative variation of critical rate of decrease of main current (dI/dt)c versus junction temperature**

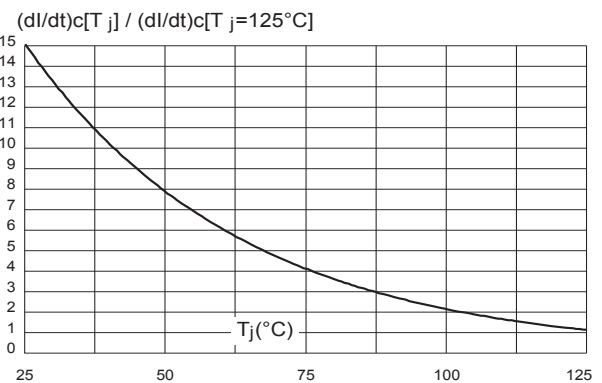

**Figure 11. Relative variation of static dV/dt immunity versus junction temperature (gate open)**

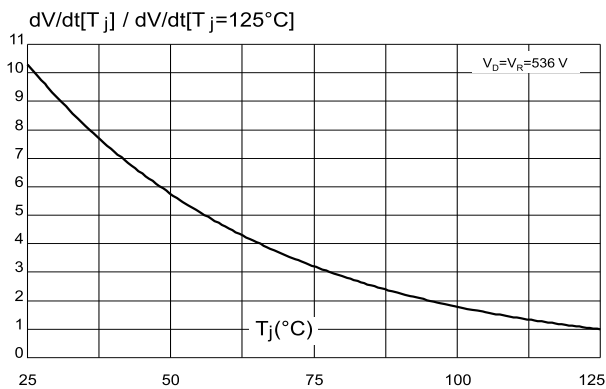

**Figure 12. Relative variation of leakage current versus junction temperature**

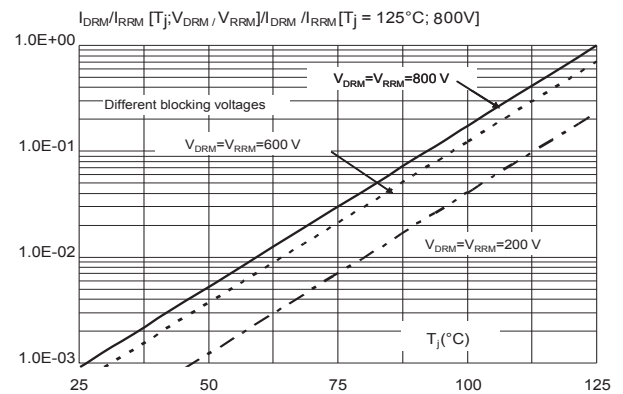

**Figure 13. Relative variation of the clamping voltage versus junction temperature (minimum values)**

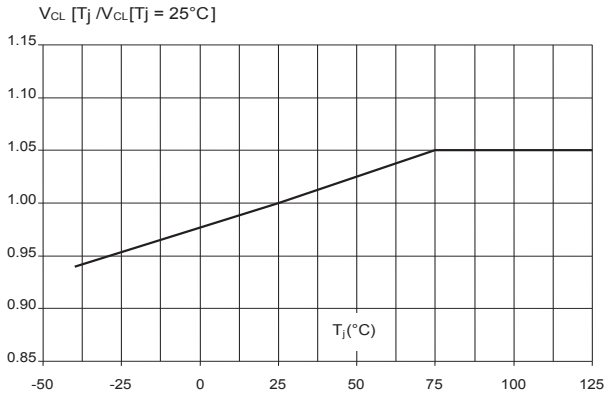

**Figure 14. Thermal resistance junction to ambient versus copper surface under tab (typical values)**

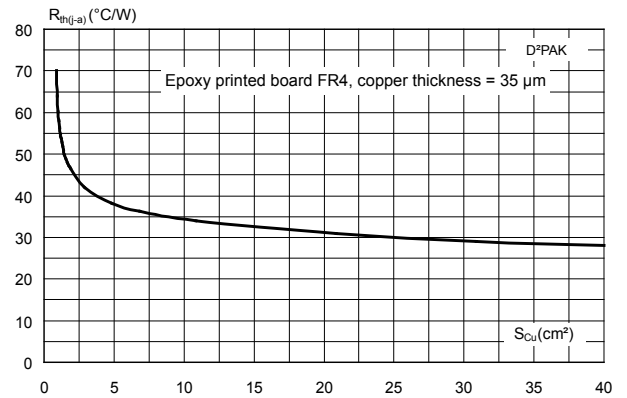

## 2 Application information

### 2.1 Typical application descriptions

The ACST8 device has been designed to control medium power load, such as AC motors in home appliances. Thanks to its thermal and turn off commutation performances, the ACST8 switch is able to drive an inductive load up to 8 A with no turn off additional snubber. It also provides high thermal performances in static and transient modes such as high torque operating conditions or inrush current of an AC motor.

Figure 15. AC induction motor control – typical diagram

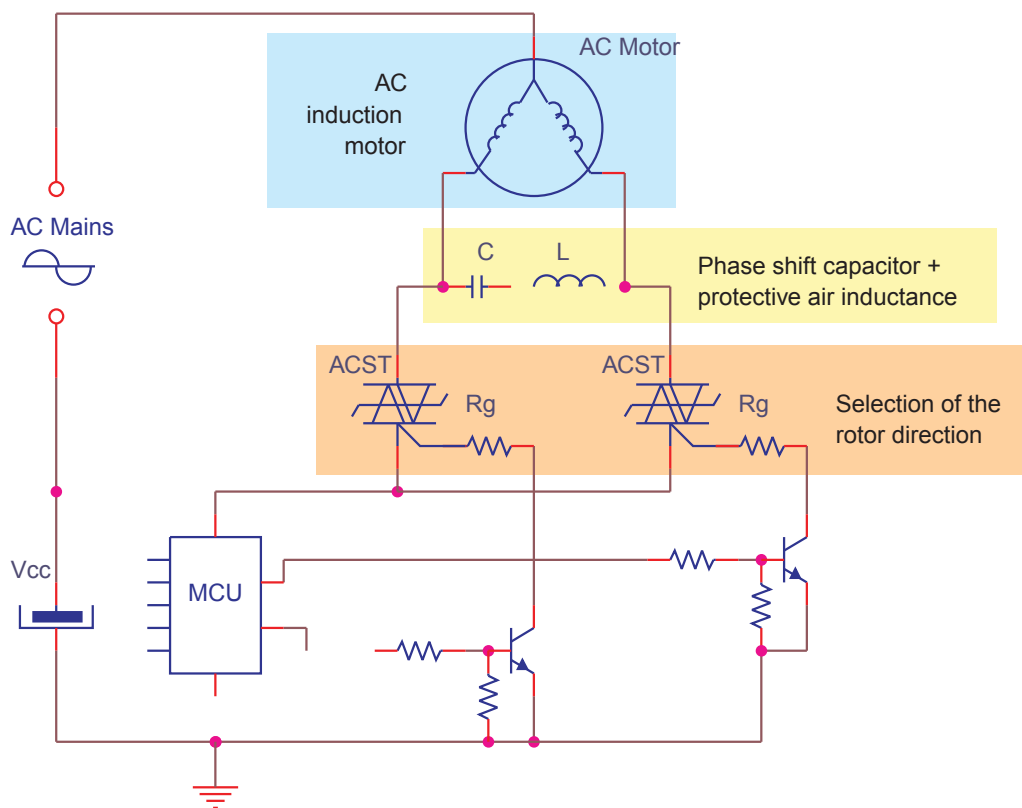

## 2.2 AC line transient voltage ruggedness

In comparison with standard Triacs, which are not robust against surge voltage, the ACST8 is self-protected against over-voltage, specified by the new parameter  $V_{CL}$ . The ACST8 switch can safely withstand AC line transient voltages either by clamping the low energy spikes, such as inductive spikes at switch off, or by switching to the on state (for less than 10 ms) to dissipate higher energy shocks through the load. This safety feature works even with high turn-on current ramp up.

The test circuit of Figure 17 represents the ACST8 application, and is used to stress the ACST switch according to the IEC 61000-4-5 standard conditions. With the additional effect of the load which is limiting the current, the ACST switch withstands the voltage spikes up to 2 kV on top of the peak line voltage. The protection is based on an overvoltage crowbar technology. The ACST8 folds back safely to the on state as shown in Figure 18. The ACST4 recovers its blocking voltage capability after the surge and the next zero current crossing.

Such a non repetitive test can be done at least 10 times on each AC line voltage polarity.

**Figure 16. Overvoltage ruggedness test circuit for resistive and inductive loads for IEC 61000-4-5 standards**

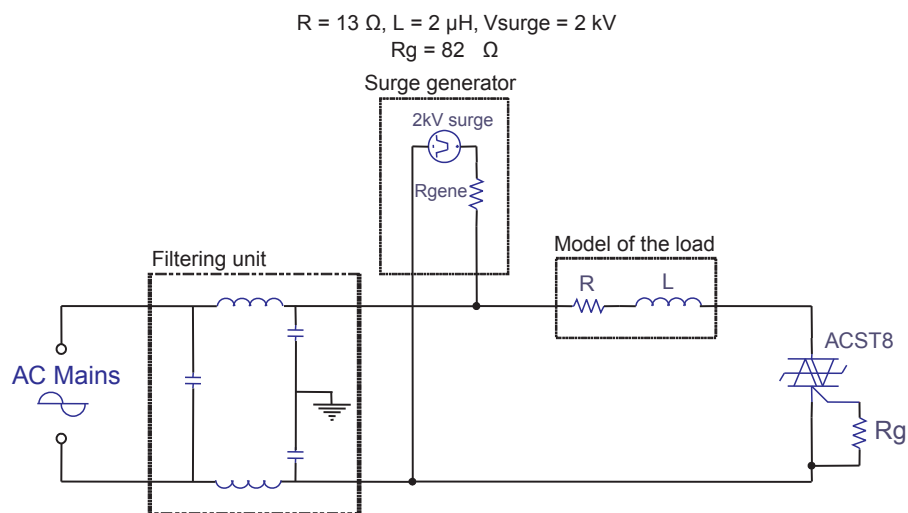

**Figure 17. Typical voltage and current waveforms across the ACST8 during IEC 61000-4-5 standard test**

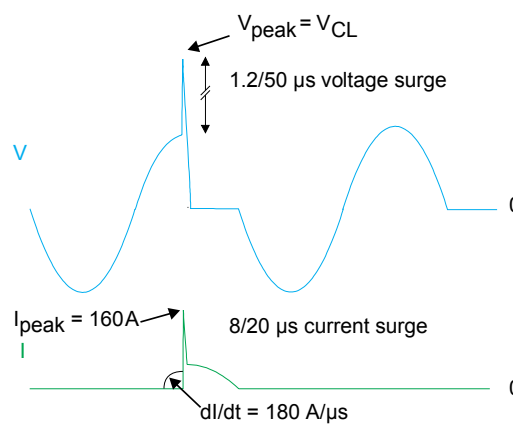



### 3 Package information

In order to meet environmental requirements, ST offers these devices in different grades of **ECOPACK** packages, depending on their level of environmental compliance. ECOPACK specifications, grade definitions and product status are available at: [www.st.com](http://www.st.com). ECOPACK is an ST trademark.

#### 3.1 TO-220AB package information

- Molding compounded resin is halogen free and meets UL94 flammability standard, level V0
- Lead-free package leads plating
- Cooling method: by conduction (C)
- Recommended torque value: 0.55 N·m
- Maximum torque value: 0.70 N·m

Figure 18. TO-220AB package outline

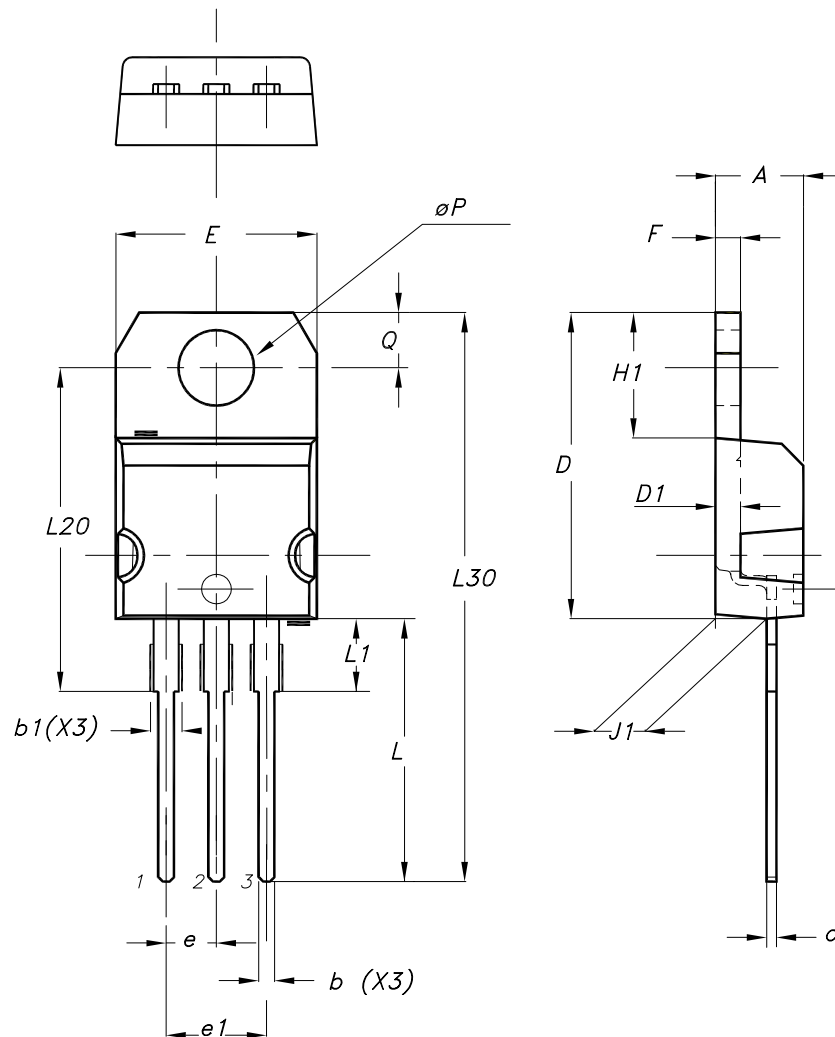

**Table 5. TO-220AB package mechanical data**

Ref.	Dimensions			
	Millimeters		Inches (for reference only)	
	Min.	Max.	Min.	Max.
A	4.40	4.60	0.1732	0.1811
b	0.61	0.88	0.0240	0.0346
b1	1.14	1.55	0.0449	0.0610
c	0.48	0.70	0.0189	0.0276
D	15.25	15.75	0.6004	0.6201
D1	1.27 typ.		0.0500 typ.	
E	10.00	10.40	0.3937	0.4094
e	2.40	2.70	0.0945	0.1063
e1	4.95	5.15	0.1949	0.2028
F	1.23	1.32	0.0484	0.0520
H1	6.20	6.60	0.2441	0.2598
J1	2.40	2.72	0.0945	0.1071
L	13.00	14.00	0.5118	0.5512
L1	3.50	3.93	0.1378	0.1547
L20	16.40 typ.		0.6457 typ.	
L30	28.90 typ.		1.1378 typ.	
θP	3.75	3.85	0.1476	0.1516
Q	2.65	2.95	0.1043	0.1161

### 3.2 TO-220FPAB package information

- Epoxy meets UL94, V0
- Recommended torque: 0.4 to 0.6 N·m

Figure 19. TO-220FPAB package outline

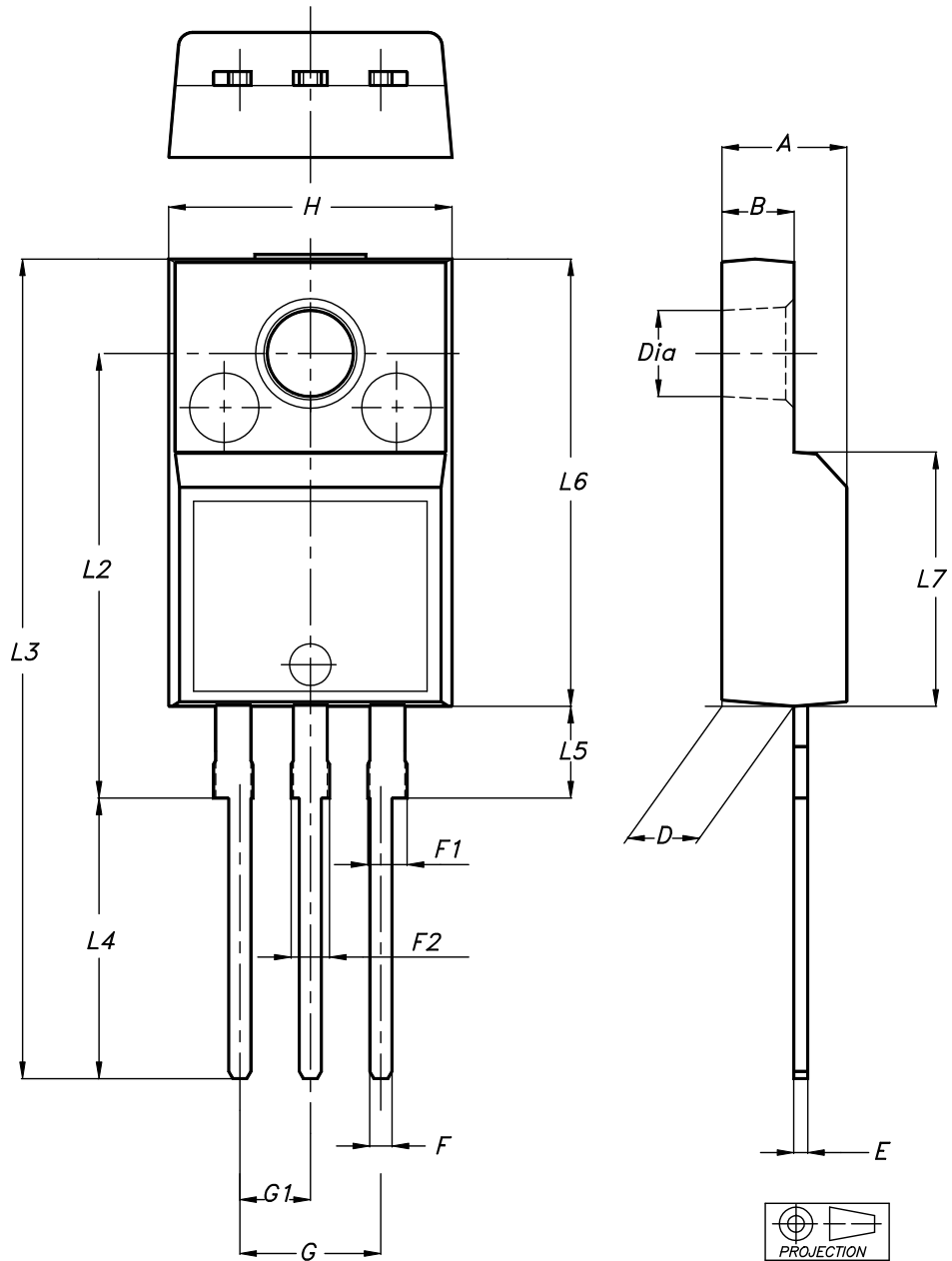

**Table 6. TO-220FPAB package mechanical data**

Ref.	Dimensions			
	Millimeters		Inches	
	Min.	Max.	Min.	Max.
A	4.40	4.60	0.1739	0.1818
B	2.5	2.7	0.0988	0.1067
D	2.50	2.75	0.0988	0.1087
E	0.45	0.70	0.0178	0.0277
F	0.75	1.0	0.0296	0.0395
F1	1.15	1.70	0.0455	0.0672
F2	1.15	1.70	0.0455	0.0672
G	4.95	5.20	0.1957	0.2055
G1	2.40	2.70	0.0949	0.1067
H	10.00	10.40	0.3953	0.4111
L2	16.00 typ.		0.6324 typ.	
L3	28.60	30.60	1.1304	1.2095
L4	9.80	10.6	0.3874	0.4190
L5	2.90	3.60	0.1146	0.1423
L6	15.90	16.40	0.6285	0.6482
L7	9.00	9.30	0.3557	0.3676
Dia	3.0	3.20	0.1186	0.1265

### 3.3 D<sup>2</sup>PAK package information

- Epoxy meets UL94, V0.
- Cooling method: by conduction (C)

Figure 20. D<sup>2</sup>PAK package outline

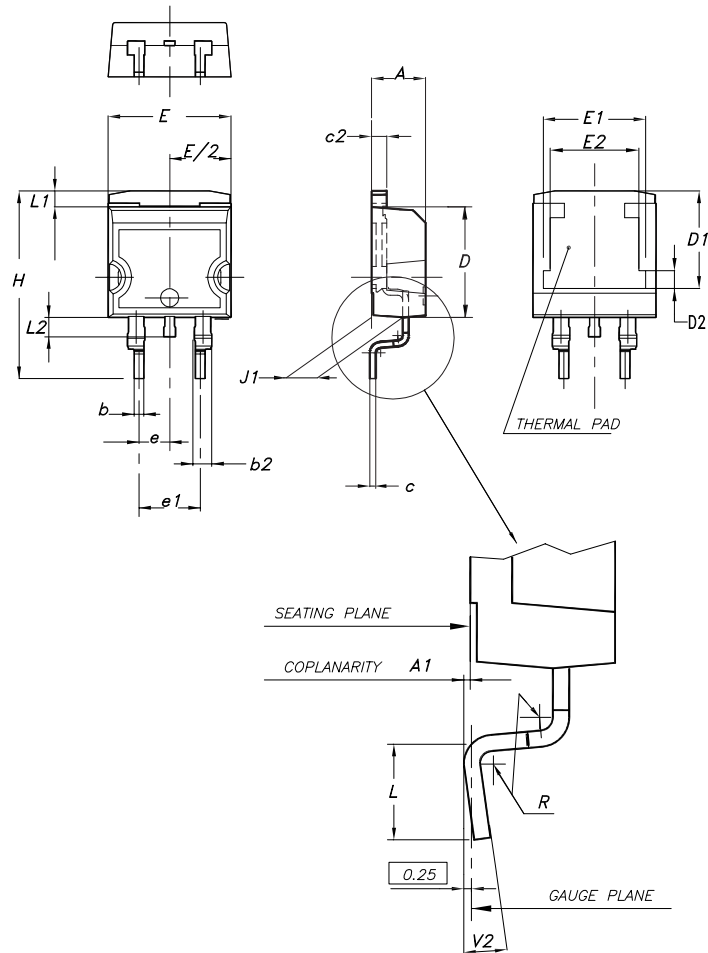

*Note:* This package drawing may slightly differ from the physical package. However, all the specified dimensions are guaranteed.

Table 7. D<sup>2</sup>PAK package mechanical data

Ref.	Dimensions					
	Millimeters			Inches (for reference only)		
	Min.	Typ.	Max.	Min.	Typ.	Max.
A	4.40		4.60	0.173		0.181
A1	0.03		0.23	0.001		0.009
b	0.70		0.93	0.028		0.037
b2	1.14		1.70	0.045		0.067
c	0.45		0.60	0.018		0.024
c2	1.23		1.36	0.048		0.053
D	8.95		9.35	0.352		0.368
D1	7.50	7.75	8.00	0.295	0.305	0.315
D2	1.10	1.30	1.50	0.043	0.051	0.060
E	10.00		10.40	0.394		0.409
E1	8.30	8.50	8.70	0.335	0.343	0.346
E2	6.85	7.05	7.25	0.266	0.278	0.282
e		2.54			0.100	
e1	4.88		5.28	0.190		0.205
H	15.00		15.85	0.591		0.624
J1	2.49		2.69	0.097		0.106
L	2.29		2.79	0.090		0.110
L1	1.27		1.40	0.049		0.055
L2	1.30		1.75	0.050		0.069
R		0.40			0.015	
V2	0°		8°	0°		8°

Figure 21. D<sup>2</sup>PAK recommended footprint (dimensions are in mm)

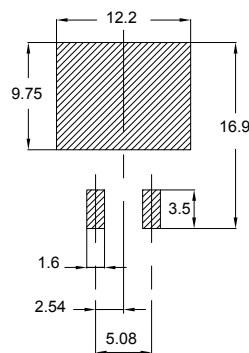

## 4 Ordering information

Figure 22. Ordering information scheme

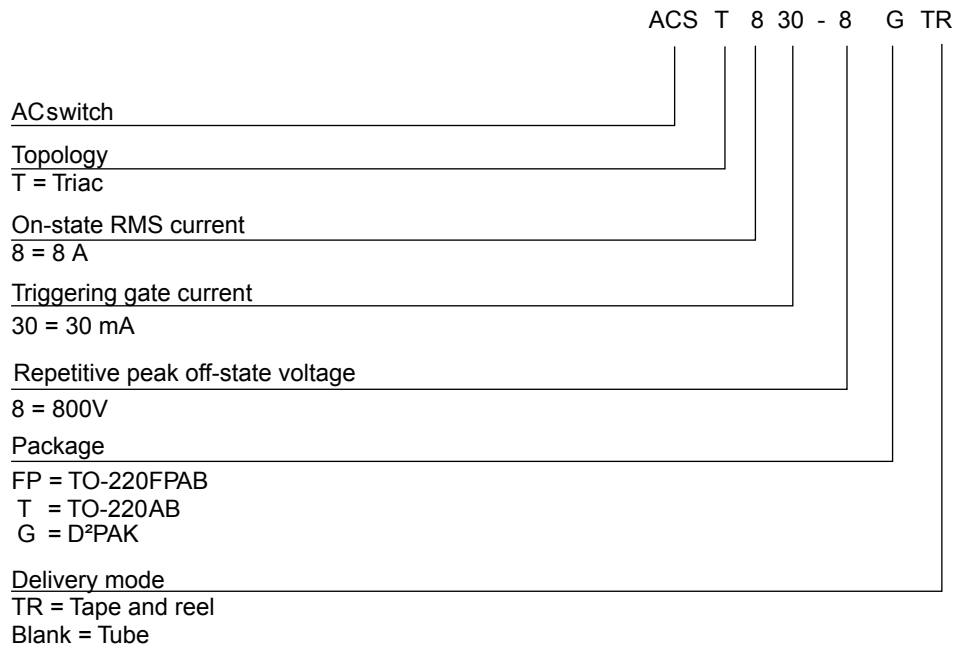

Table 8. Ordering information

Order code	Marking	Package	Weight	Base qty.	Packing mode
ACST830-8FP	ACST8308	TO-220FPAB	2.4 g	50	Tube
ACST830-8T		TO-220AB	2.3 g	50	Tube
ACST830-8GTR		D <sup>2</sup> PAK	1.5 g	1000	Tape and reel

## Revision history

**Table 9. Document revision history**

Date	Revision	Changes
Jan-2002	4B	Last update.
08-Nov-2004	5	TO-220AB and D <sup>2</sup> PAK packages added.
24-Nov-2004	6	Table 6 page 3: I <sub>GT</sub> parameter added.
18-Dec-2009	7	Added ECOPACK statement. Reformatted for consistency with other datasheets in this product class. Order codes updated.
01-Jul-2010	8	Updated Figure 19.
07-Feb-2011	9	Updated Table 2.
04-Sep-2017	10	Updated features in cover page and Table 2. Updated Section 4: Package information. Minor text changes.
29-Sep-2021	11	Updated D <sup>2</sup> PAK package information.



**IMPORTANT NOTICE – PLEASE READ CAREFULLY**

STMicroelectronics NV and its subsidiaries (“ST”) reserve the right to make changes, corrections, enhancements, modifications, and improvements to ST products and/or to this document at any time without notice. Purchasers should obtain the latest relevant information on ST products before placing orders. ST products are sold pursuant to ST’s terms and conditions of sale in place at the time of order acknowledgement.

Purchasers are solely responsible for the choice, selection, and use of ST products and ST assumes no liability for application assistance or the design of Purchasers’ products.

No license, express or implied, to any intellectual property right is granted by ST herein.

Resale of ST products with provisions different from the information set forth herein shall void any warranty granted by ST for such product.

ST and the ST logo are trademarks of ST. For additional information about ST trademarks, please refer to [www.st.com/trademarks](http://www.st.com/trademarks). All other product or service names are the property of their respective owners.

Information in this document supersedes and replaces information previously supplied in any prior versions of this document.

© 2021 STMicroelectronics – All rights reserved