

Brief Description

The ZSPM1005 is a configurable true-digital single-phase PWM controller for high-current, non-isolated DC/DC supplies. It operates as a synchronous step-down converter in a single-rail and single-phase configuration.

The ZSPM1005 integrates a digital control loop, optimized for maximum flexibility and stability as well as load step and steady-state performance. In addition, a rich set of protection and monitoring functions is provided. To facilitate user configuration of the part, a set of configuration options can be pre-programmed in the ZSPM1005 that can be selected by setting the values of two external resistors.

IDT's Pink Power Designer™; a PC-based, user-friendly interface to the ZSPM1005, can be used to expedite the design of the digital compensator. It offers intuitive configuration methods for additional features, such as protection and sequencing. Once the part is programmed, the resistor options can be used to select the required configuration without a digital bus.

Features

- Programmable digital control loop
- Advanced, digital control techniques
 - Tru-sample Technology™
 - State-Law Control™ (SLC)
 - Sub-cycle Response™ (SCR)
- Improved transient response and noise immunity
- Protection features
 - Over-current protection
 - Over-voltage protection (VIN, VOUT)
 - Under-voltage protection (VIN, VOUT)
 - Overloaded startup
 - Restart and delay
- Support for SMOD and ZCD drivers
- Fuse-based one-time programmable (OTP) nonvolatile memory for improved reliability
- Operation from a single 5V or 3.3V supply
- 2-pin configuration for compensation, output voltage, and more

Benefits

- Fast configuration and design flexibility improves time-to-market
- Simplified design and integration
- FPGA designer-friendly solution
- Highest power density with smallest footprint
- Pin-to-pin compatible with the ZSPM1000 PWM controller enabling point-of-load power module platform designs with or without digital communication
- Higher energy efficiency across all output loading conditions

Available Support

- Evaluation Kit
- PC-based Pink Power Designer™

Physical Characteristics

- Operation temperature: -40°C to +125°C
- V_{OUT} max: 5V
- Lead free (RoHS compliant) 24-pin QFN package (4mm x 4mm)

ZSPM1005 Typical Application Diagram

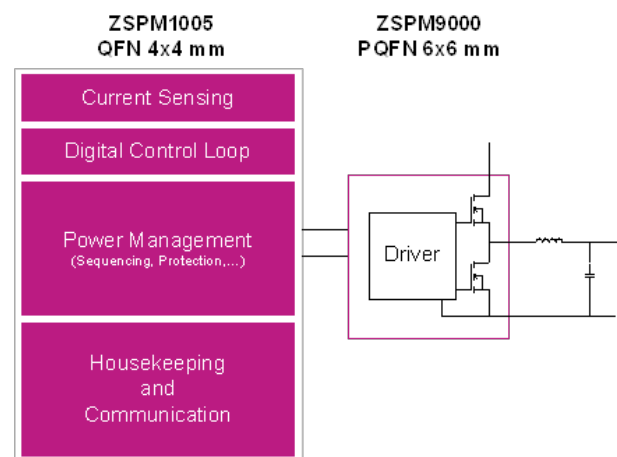

ZSPM1005 Block Diagram

Optimal Applications

- ❖ *FPGA designs*
- ❖ *Point-of-load power modules for single-phase applications including telecommunication, base stations, servers and storage*

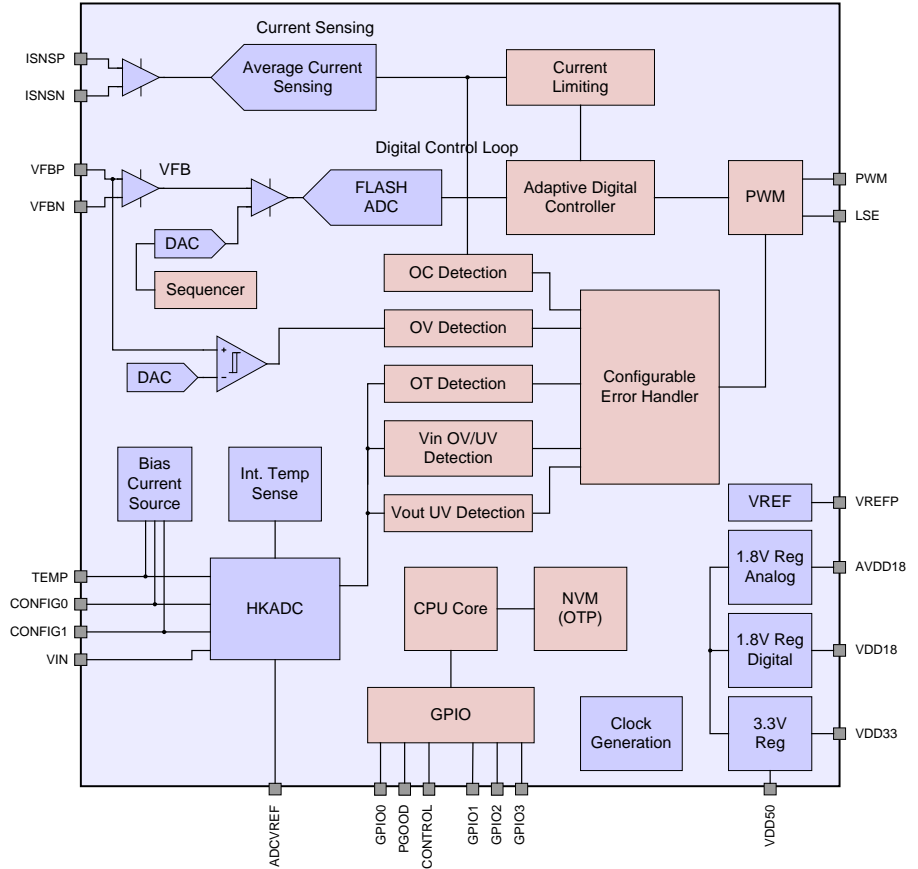

Ordering Information

Product Sales Code	Description	Package
ZSPM1005ZA1R 0	ZSPM1005 Lead-free QFN24 — Temperature range: -40°C to +125°C	Reel
ZSPM8001-KIT	Integrated Evaluation Kit for ZSPM9060 and ZSPM1005 - closed loop evaluation board	Kit

IMPORTANT NOTICE AND DISCLAIMER

RENESAS ELECTRONICS CORPORATION AND ITS SUBSIDIARIES (“RENESAS”) PROVIDES TECHNICAL SPECIFICATIONS AND RELIABILITY DATA (INCLUDING DATASHEETS), DESIGN RESOURCES (INCLUDING REFERENCE DESIGNS), APPLICATION OR OTHER DESIGN ADVICE, WEB TOOLS, SAFETY INFORMATION, AND OTHER RESOURCES “AS IS” AND WITH ALL FAULTS, AND DISCLAIMS ALL WARRANTIES, EXPRESS OR IMPLIED, INCLUDING, WITHOUT LIMITATION, ANY IMPLIED WARRANTIES OF MERCHANTABILITY, FITNESS FOR A PARTICULAR PURPOSE, OR NON-INFRINGEMENT OF THIRD PARTY INTELLECTUAL PROPERTY RIGHTS.

These resources are intended for developers skilled in the art designing with Renesas products. You are solely responsible for (1) selecting the appropriate products for your application, (2) designing, validating, and testing your application, and (3) ensuring your application meets applicable standards, and any other safety, security, or other requirements. These resources are subject to change without notice. Renesas grants you permission to use these resources only for development of an application that uses Renesas products. Other reproduction or use of these resources is strictly prohibited. No license is granted to any other Renesas intellectual property or to any third party intellectual property. Renesas disclaims responsibility for, and you will fully indemnify Renesas and its representatives against, any claims, damages, costs, losses, or liabilities arising out of your use of these resources. Renesas' products are provided only subject to Renesas' Terms and Conditions of Sale or other applicable terms agreed to in writing. No use of any Renesas resources expands or otherwise alters any applicable warranties or warranty disclaimers for these products.

(Rev.1.0 Mar 2020)

Corporate Headquarters

TOYOSU FORESIA, 3-2-24 Toyosu,
Koto-ku, Tokyo 135-0061, Japan
www.renesas.com

Contact Information

For further information on a product, technology, the most up-to-date version of a document, or your nearest sales office, please visit:
www.renesas.com/contact/

Trademarks

Renesas and the Renesas logo are trademarks of Renesas Electronics Corporation. All trademarks and registered trademarks are the property of their respective owners.