

# CMPA0527005F

5 W, 0.5 - 2.7 GHz, 50 V, GaN HEMT

## Description

CMPA0527005F is packaged gallium nitride (GaN) High Electron Mobility Transistor (HEMT) based monolithic microwave integrated circuit (MMIC). This device is matched to 50 ohms at the input and unmatched at the output. This device operates from a 50 V rail and is intended to be used as a predriver from 0.5 to 2.7 GHz. The transistor is available in a 6 leaded flange package.

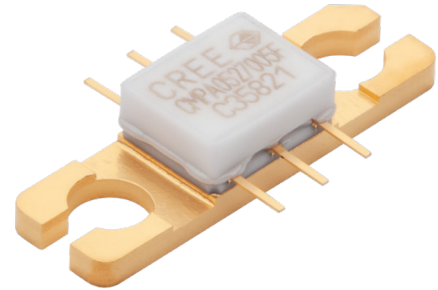

Package Types: 440221  
PN: CMPA0527005F

## Typical Performance Over 0.5 - 2.7 GHz ( $T_c = 25^\circ\text{C}$ ), 50 V, $P_{IN} = 24\text{ dBm}$ , CW

Parameter	0.5 GHz	1.0 GHz	1.5 GHz	2.0 GHz	2.7 GHz	Units
Small Signal Gain	20.4	20.8	21	20.5	19.5	dB
Output Power	7.8	9.3	9.1	8.7	6.6	W
Drain Efficiency	58.5	53.8	49.2	47.1	41.5	%

Note: Measured in the CMPA0527005F-AMP1 application circuit

## Features

- Up to 2.7 GHz Operation
- 8 W Typical Output Power
- 20 dB Small Signal Gain
- Application Circuit for 0.5 - 2.7 GHz
- 50% Efficiency
- 50 V Operation

 Large Signal Models Available for ADS and MWO

**RoHS**  
COMPLIANT



**Absolute Maximum Ratings (not simultaneous) at 25 °C Case Temperature**

Parameter	Symbol	Rating	Units	Conditions
Drain-Source Voltage	$V_{DSS}$	150	Volts	25 °C
Gate-to-Source Voltage	$V_{GS}$	-10, +2	Volts	25 °C
Storage Temperature	$T_{STG}$	-65, +150	°C	
Operating Junction Temperature	$T_J$	225	°C	
Maximum Forward Gate Current	$I_{GMAX}$	1.2	mA	25 °C
Maximum Drain Current <sup>1</sup>	$I_{DMAX}$	0.5	A	25 °C
Soldering Temperature <sup>2</sup>	$T_S$	245	°C	
Screw Torque	$\tau$	40	in-oz	
Thermal Resistance, Junction to Case <sup>3</sup>	$R_{\theta JC}$	18	°C/W	85 °C
Case Operating Temperature <sup>4</sup>	$T_C$	-40, +75	°C	

Notes:

<sup>1</sup> Current limit for long term, reliable operation

<sup>2</sup> Refer to the Application Note on soldering at [wolfspeed.com/rf/document-library](http://wolfspeed.com/rf/document-library)

<sup>3</sup> Measured for the CMPA0527005F at  $P_{DISS} = 8.4 W$

<sup>4</sup> See also, Power Derating Curve on Page 5

**Electrical Characteristics ( $T_C = 25 °C$ )**

Characteristics	Symbol	Min.	Typ.	Max.	Units	Conditions
<b>DC Characteristics<sup>1</sup></b>						
Gate Threshold Voltage	$V_{GS(th)}$	-3.8	-3.0	-2.3	$V_{DC}$	$V_{DS} = 10 V, I_D = 1.2 mA$
Gate Quiescent Voltage	$V_{GS(Q)}$	-	-2.7	-	$V_{DC}$	$V_{DS} = 50 V, I_D = 0.11 A$
Saturated Drain Current <sup>2</sup>	$I_{DS}$	0.78	1.12	-	A	$V_{DS} = 6.0 V, V_{GS} = 2.0 V$
Drain-Source Breakdown Voltage	$V_{BR}$	100	-	-	$V_{DC}$	$V_{GS} = -8 V, I_D = 1.2 mA$
<b>RF Characteristics<sup>3,4,5</sup> (<math>T_C = 25 °C, F_0 = 2.7 GHz</math> unless otherwise noted)</b>						
Small Signal Gain	S21	17	18.5	-	dB	$V_{DD} = 50 V, I_{DQ} = 0.11 A, P_{IN} = 10 dBm$
Power Gain	$G_P$	-	13.5	-	dB	$V_{DD} = 50 V, I_{DQ} = 0.11 A$
Output Power	$P_{OUT}$	38.6	39.5	-	dBm	$V_{DD} = 50 V, I_{DQ} = 0.11 A$
Drain Efficiency	$\eta$	49	58.0	-	%	$V_{DD} = 50 V, I_{DQ} = 0.11 A$
Output Mismatch Stress	VSWR	-	-	10:1	$\Psi$	No damage at all phase angles, $V_{DD} = 50 V, I_{DQ} = 0.11 A, P_{OUT} = 5 W CW$
<b>Dynamic Characteristics<sup>6</sup></b>						
Output Capacitance	$C_{DS}$	-	0.8	-	pF	$V_{DS} = 50 V, V_{GS} = -8 V, f = 1 MHz$

Notes:

<sup>1</sup> Measured on-wafer prior to packaging.

<sup>2</sup> Scaled from PCM data

<sup>3</sup> Measured in Cree’s production test fixture

<sup>4</sup>  $P_{IN} = 26 dBm$

<sup>5</sup> CW

<sup>6</sup> Includes package



**CMPA0527005F Typical Performance in CMPA0527005F-AMP1 Application Circuit**

**Figure 1. Small Signal Gain, Return Losses versus Frequency of the CMPA0527005F**  
 $V_{DD} = 50\text{ V}, I_{DQ} = 0.110\text{ A}$

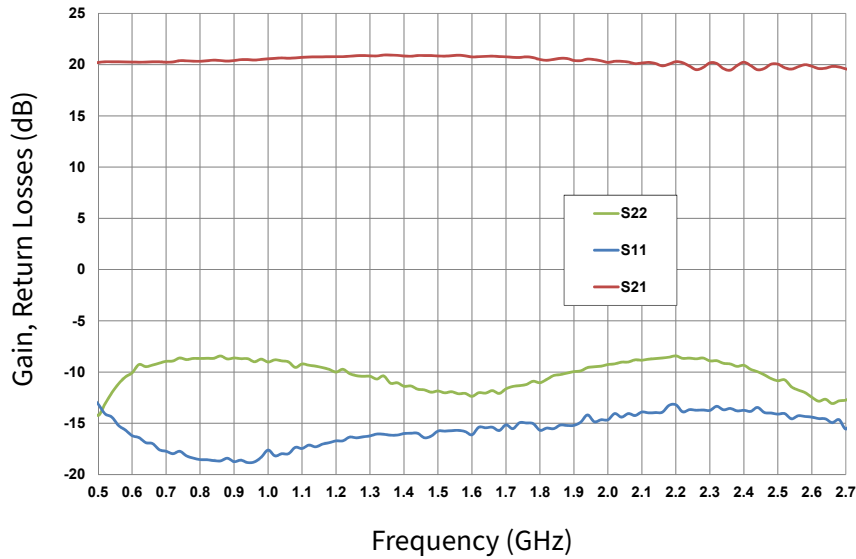

**Figure 2. Output Power, Power Added Efficiency and Gain vs Frequency of the CMPA0527005F as measured in demonstration amplifier circuit CMPA0527005F-AMP1**  
 $V_{DD} = 50\text{ V}, I_{DQ} = 0.110\text{ A}, P_{IN} = 24\text{ dBm CW}, T_{case} = 25^\circ\text{C}$

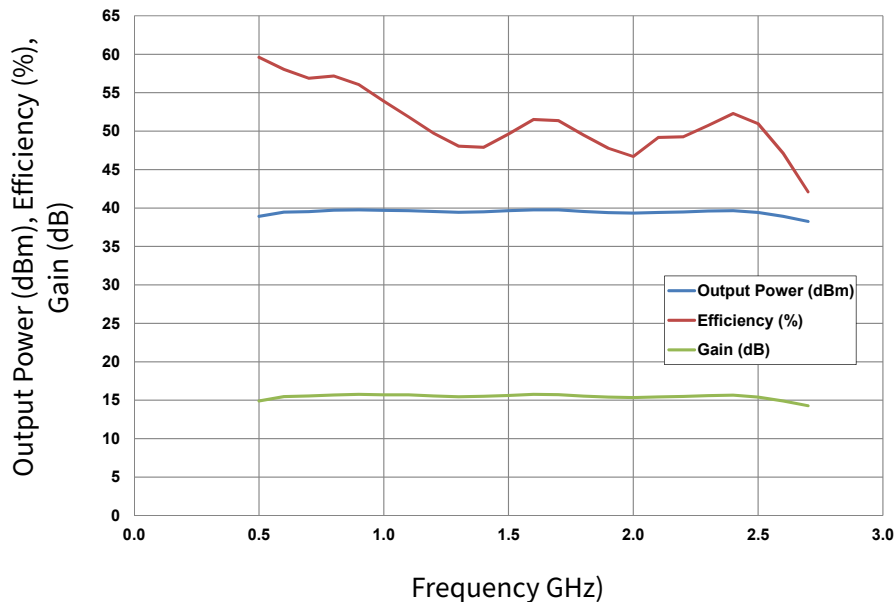



**CMPA0527005F Typical Performance in CMPA0527005F-AMP1 Application Circuit**

**Figure 3. Gain (dB) and Efficiency (%) vs Output Power (dBm) of the CMPA0527005F as measured in demonstration amplifier circuit CMPA0527005F-AMP1**  
 $V_{DD} = 50\text{ V}$ ,  $I_{DQ} = 0.110\text{ A}$ ,  $T_{case} = 25^\circ\text{C}$

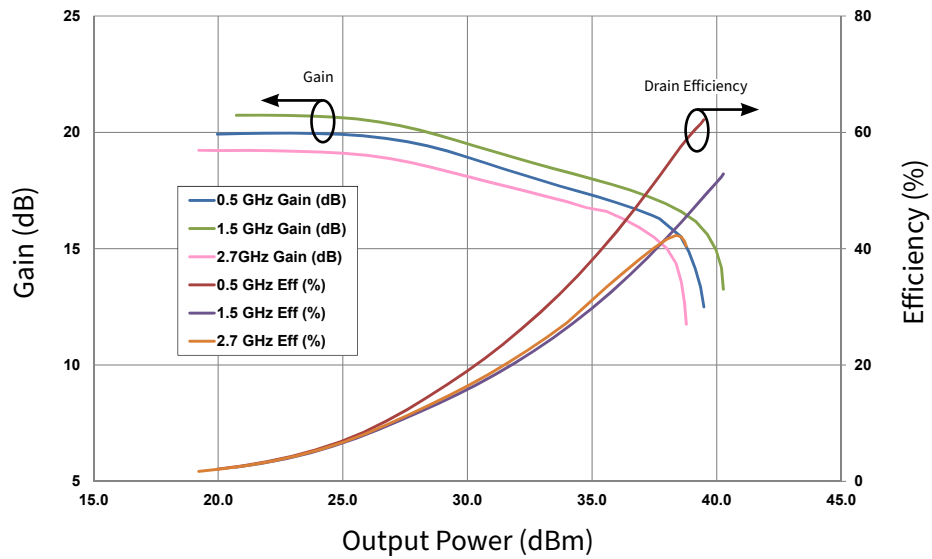

**Figure 4. Third Order Intermodulation Distortion vs Output Power measured in demonstration amplifier circuit CMPA0527005F-AMP1**  
 $V_{DD} = 50\text{ V}$ ,  $I_{DQ} = 0.110\text{ A}$ ,  $T_{case} = 25^\circ\text{C}$ ,  $\Delta f = 1\text{ MHz}$

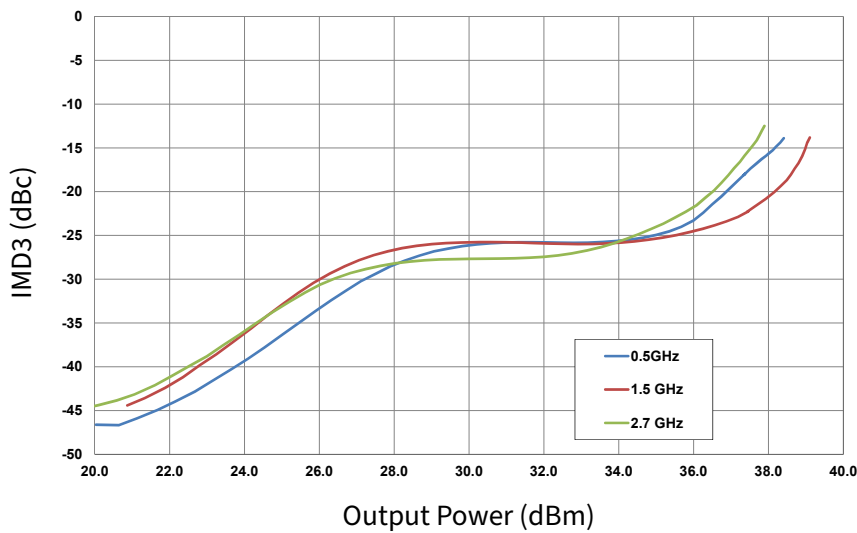



**CMPA0527005F Typical Performance**

**Figure 5. Simulated  $G_{MAX}$  and K-Factor vs Frequency**  
 $V_{DD} = 50\text{ V}$ ,  $I_{DQ} = 0.110\text{ A}$ ,  $T_{case} = 25^\circ\text{C}$

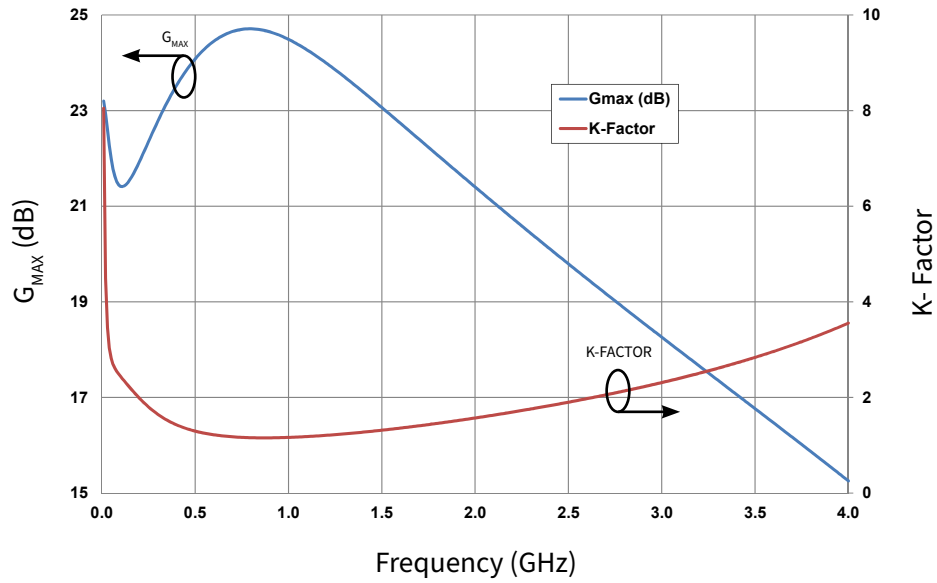

**CMPA0527005F Power Dissipation De-rating Curve**

**Figure 6. Transient Power Dissipation De-Rating Curve**

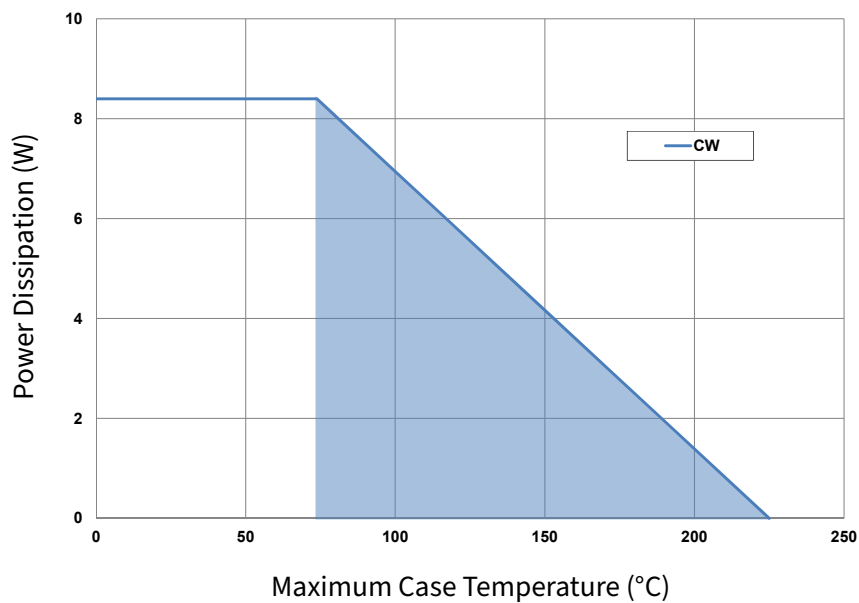

Note: Shaded area exceeds Maximum Case Temperature (See Page 2).



**Source and Load Impedances**

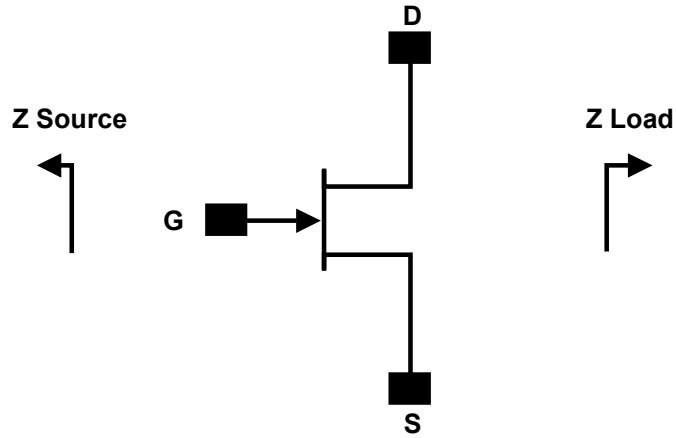

Frequency (GHz)	Z Load
0.5	143+j115
1	63.18+j93.20
1.5	39.49+j67.24
2	40.13+j42.78
2.3	40.19+j42.82
2.7	30.48+j29.17

Note 1.  $V_{DD} = 50\text{ V}$ ,  $I_{DQ} = 0.110\text{ A}$  in the 440221 package  
 Note 2. Optimized for power gain,  $P_{SAT}$  and PAE

**Electrostatic Discharge (ESD) Classifications**

Parameter	Symbol	Class	Test Methodology
Human Body Model	HBM	1A (> 250 V)	JEDEC JESD22 A114-D
Charge Device Model	CDM	2 (125 V to 250 V)	JEDEC JESD22 C101-C



**CMPA0527005F-AMP1 Application Circuit Schematic**

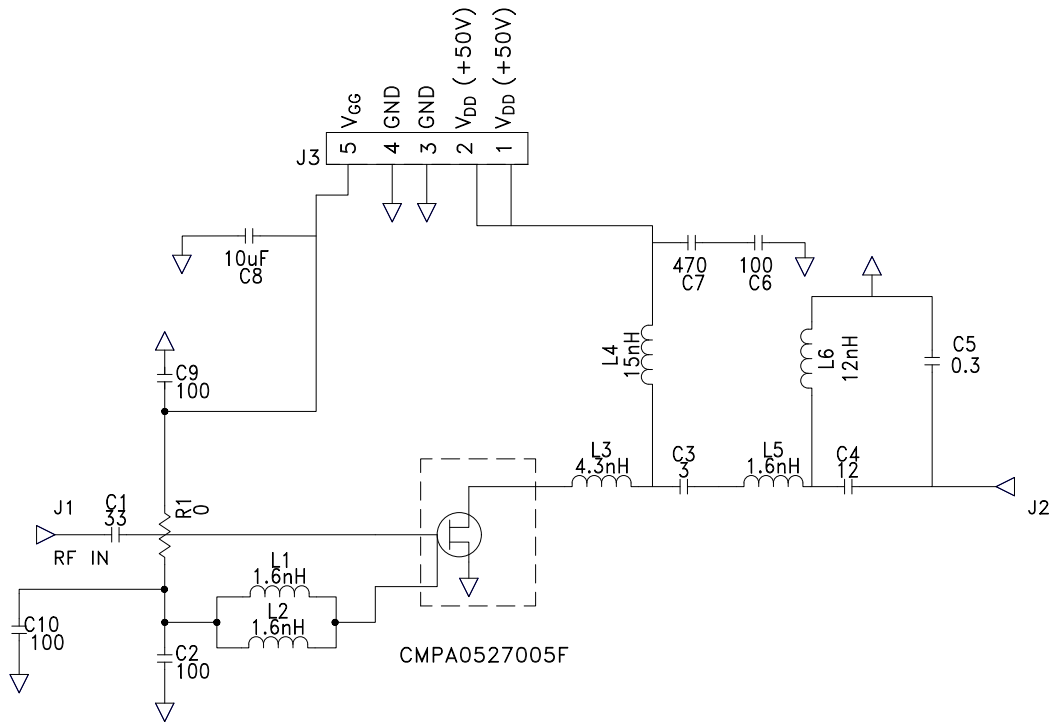

**CMPA0527005F-AMP1 Application Circuit**

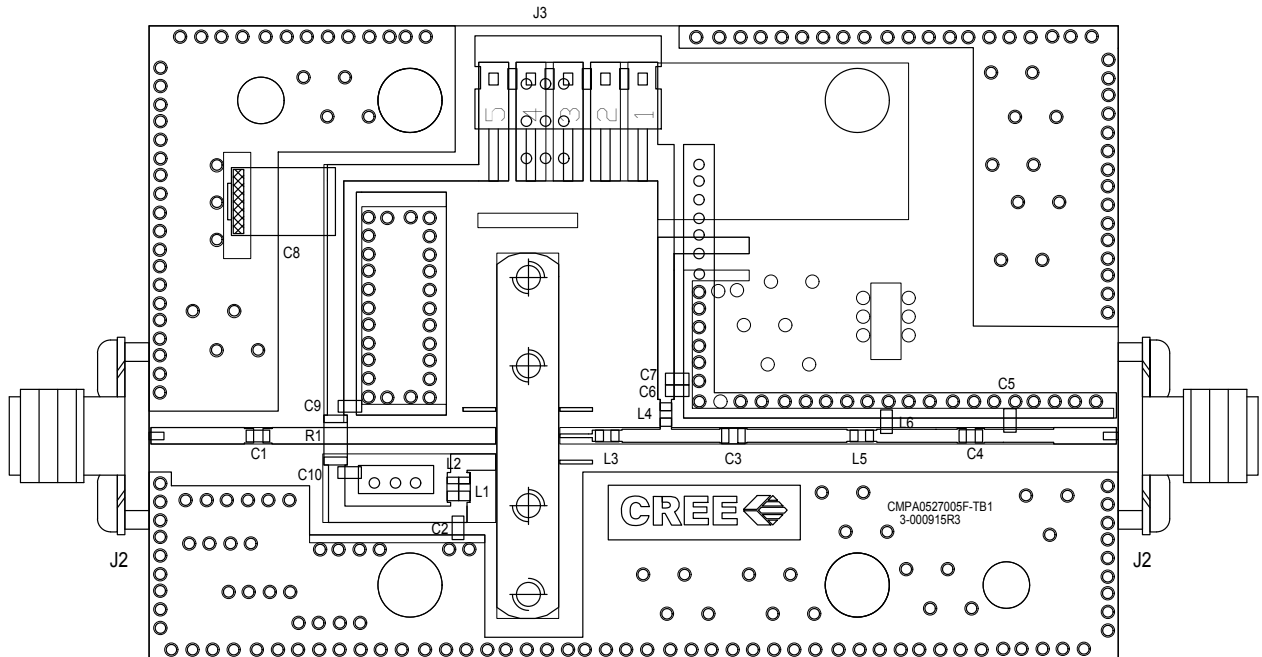



**CMPA0527005F-AMP1 Application Circuit Bill of Materials**

Designator	Description	Qty
C1	CAP, 33PF, 5%, 0603, ATC	1
C2, C6, C9	CAP, 100PF, 5%, 0603, ATC	3
C3	CAP, 3PF, 5%, 0805, ATC	1
C4	CAP, 12PF, 5%, 0603, ATC	1
C5	CAP, 0.3pF, 5%, 0603, ATC	1
C7	CAP, 470pF, 5%, 0603,100V. X7R	1
C8	CAP, 33000pF, 0805,100V,X7R	1
R1	RES, 1/16W, 1206, 1%, 0 Ohms	1
L1,L2,L5	INDUCTOR,CHIP,1.6nH,0603CS SMT	3
L3	INDUCTOR,CHIP,4.3nH,0603CS SMT	1
L4	INDUCTOR,CHIP,15nH,0603HP SMT	1
L6	INDUCTOR,CHIP,12nH,0603CS SMT	1
Q1	Transistor CMPA0527005F	1
	PCB, RO4350, CMPA0527005F Applications Board, 1.7" X 2.6"X0.02"	1
	BASEPLATE, AL, 2.60 X 1.7 X 0.25	1
	2-56 SOC HD SCREW 1/4 SS	4
	#2 SPLIT LOCKWASHER SS	4
J1,J2	CONN, SMA, PANEL MOUNT JACK, FLANGE, 4-HOLE, BLUNT POST, 20MIL	2
J3	HEADER RT>PLZ .1CEN LK 5POS	1

**CMPA0527005F-AMP1 Demonstration Amplifier Circuit**

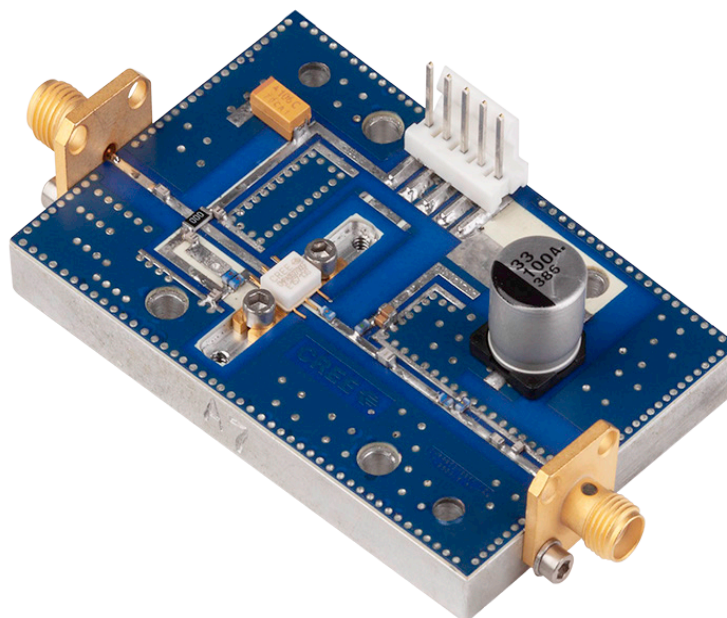





**Product Dimensions CMPA0527005F (Package Type – 440221)**

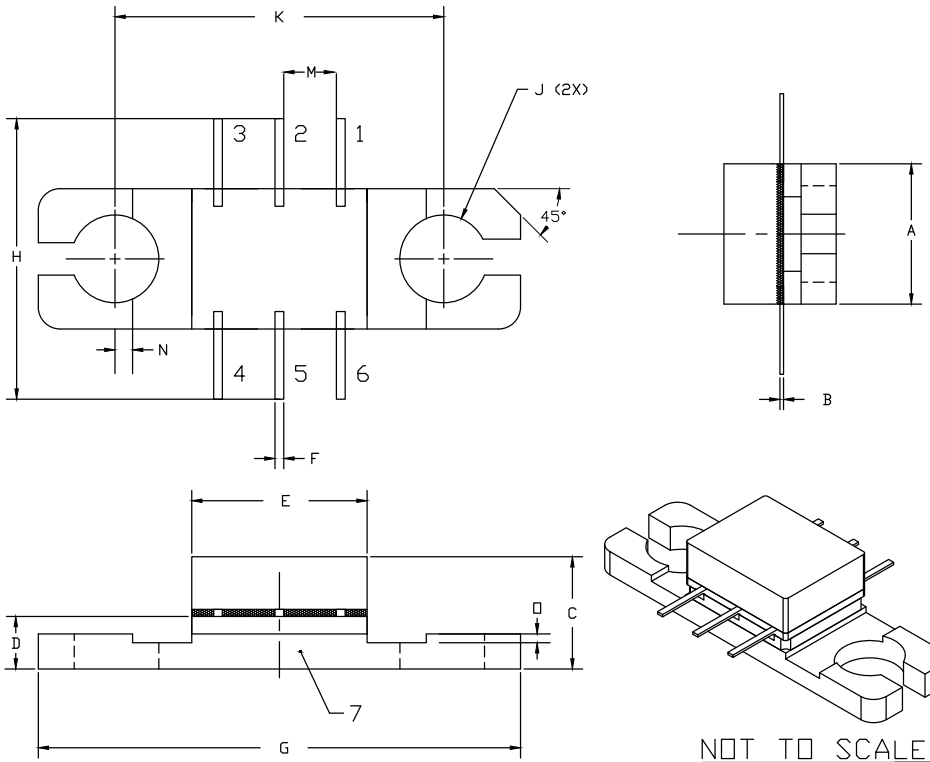

NOTES:

1. DIMENSIONING AND TOLERANCING PER ANSI Y14.5M, 1982.
2. CONTROLLING DIMENSION: INCH.
3. ADHESIVE FROM LID MAY EXTEND A MAXIMUM OF 0.020" BEYOND EDGE OF LID.
4. LID MAY BE MISALIGNED TO THE BODY OF THE PACKAGE BY A MAXIMUM OF 0.008" IN ANY DIRECTION.
5. ALL PLATED SURFACES ARE NI/AU

DIM	INCHES		MILLIMETERS	
	MIN	MAX	MIN	MAX
A	0.155	0.165	3.94	4.19
B	0.003	0.005	0.076	0.127
C	0.118	0.138	3.00	3.50
D	0.055	0.065	1.40	1.65
E	0.195	0.205	4.95	5.21
F	0.009	0.011	0.23	0.28
G	0.545	0.555	13.84	14.09
H	0.280	0.360	7.11	9.14
J	Ø .100		2.54	
K	0.375		9.53	
M	0.061		1.54	
N	0.018	0.022	0.46	0.56
O	0.008	0.012	0.20	0.30

Pin Number	Qty
1	NC
2	RF <sub>IN</sub>
3	Gate Bias
4	NC
5	RF <sub>OUT</sub> + Drain Bias
6	NC
7	Source

**Part Number System**

**CMPA0527005F**

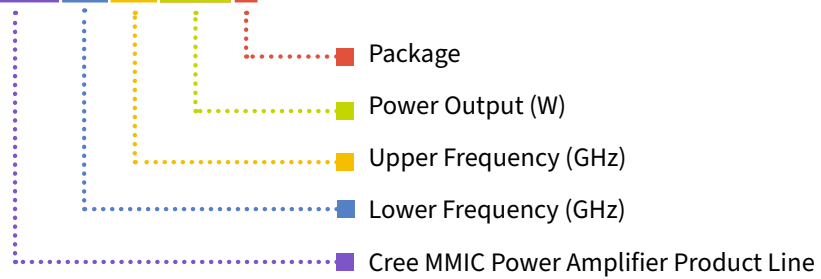

**Table 1.**

Parameter	Value	Units
Upper Frequency <sup>1</sup>	2.7	GHz
Power Output	5	W
Package	Flange	-

**Note<sup>1</sup>:** Alpha characters used in frequency code indicate a value greater than 9.9 GHz. See Table 2 for value.

**Table 2.**

Character Code	Code Value
A	0
B	1
C	2
D	3
E	4
F	5
G	6
H	7
J	8
K	9
Examples:	1A = 10.0 GHz 2H = 27.0 GHz



**Product Ordering Information**

Order Number	Description	Unit of Measure	Image
CMPA0527005F	GaN HEMT	Each	
CMPA0527005F-AMP1	Test board with GaN HEMT (flanged) installed	Each	



For more information, please contact:

4600 Silicon Drive  
Durham, North Carolina, USA 27703  
[www.wolfspeed.com/rf](http://www.wolfspeed.com/rf)

Sales Contact  
[rfsales@cree.com](mailto:rfsales@cree.com)

## Notes & Disclaimer

---

Specifications are subject to change without notice. “Typical” parameters are the average values expected by Cree in large quantities and are provided for information purposes only. Cree products are not warranted or authorized for use as critical components in medical, life-saving, or life-sustaining applications, or other applications where a failure would reasonably be expected to cause severe personal injury or death. No responsibility is assumed by Cree for any infringement of patents or other rights of third parties which may result from use of the information contained herein. No license is granted by implication or otherwise under any patent or patent rights of Cree.

© 2019 – 2021 Cree, Inc. All rights reserved. Wolfspeed® and the Wolfspeed logo are registered trademarks of Cree, Inc.