

### »Features

- Excellent clamping capability
- Low leakage current
- Low capacitance
- High surge capability
- Glass passivated chip
- Epoxy resin package
- Built-in strain relief
- Will not fatigue
- RoHS Compliant
- Fast response time:  
typically less than 1.0ps from 0 Volts to  $V_{BR}$  min



SMB (DO-214AA)

### »Mechanical Characteristics

- Package: SMB plastic package.
- Lead Finish: Matte Tin
- Case Material: Epoxy Molding Compound.
- UL Flammability Classification Rating 94V-0
- Moisture Sensitivity: Level 1 per J-STD-020

### »Applications

- Telecom
- Computer
- Industrial electronic
- Consumer electronic

### »Electrical Parameters

Parameter	Definition
$C_J$	Junction Capacitance - typical capacitance measured with 0V or $V_R$ bias
$I_{PP}$	Peak Pulse Current - maximum rated peak impulse current
$V_C$	Clamping Voltage - Peak voltage measured across the suppressor at a specified $I_{ppm}$ (peak impulse current)
$V_{BR}$	Breakdown Voltage - Maximum voltage that flows through the TVS at a specified test current ( $I_T$ )
$I_R$	Leakage Current - maximum peak off-state current measured at $V_R$
$V_R$	Peak Off-state Voltage - maximum voltage that can be applied while maintaining off state

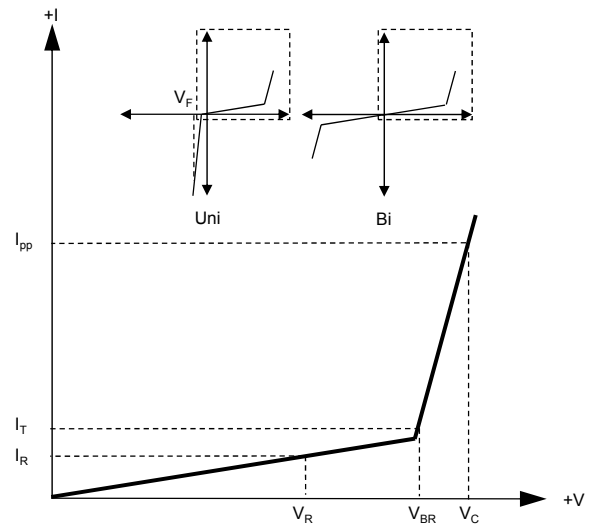

### »Summary of Packing Options

Package	Packing Description	Packing Quantity	Industry Standard
SMB	Tape/Reel, 13" reel	3000	EIA-481-1
	Tape/Reel, 7" reel	500	EIA-481-1

**»Absolute Maximum Ratings ( $T_A=25^{\circ}\text{C}$  unless otherwise noted)**

Parameter	Symbol	Value	Units	Remarks
Peak Pulse Power Dissipation	$P_{PPM}$	600	W	(Note1)(Note2)
Steady State Power Dissipation	$P_D$	5	W	(Note3)
Peak Forward Surge Current	$I_{FSM}$	100	A	(Note4)
Maximum Instantaneous Forward Voltage at 50A	$V_{FM}$	3.5/5	V	(Note5)
Typical Thermal Resistance Junction to Lead	$R_{\theta JL}$	20	$^{\circ}\text{C}/\text{W}$	
Typical Thermal Resistance Junction to Ambient	$R_{\theta JA}$	100	$^{\circ}\text{C}/\text{W}$	
Operating Temperature Range	$T_J$	-55 to 150	$^{\circ}\text{C}$	
Storage Temperature Range	$T_{STG}$	-55 to 150	$^{\circ}\text{C}$	

Notes1: Non-repetitive current pulse , 10/1000us Waveform.

Notes2: Mounted on copper pad area of 5×5mm to each terminal.

Notes3: Infinite HeatSink at  $T_A=50^{\circ}\text{C}$

Notes4: Measured on 8.3ms single half sine wave or equivalent square wave, duty cycle=4 perminute maximum.

Notes5: For UnidirectionalOnly,  $V_{FM}<3.5\text{V}$  for  $V_{BR} \leq 200\text{V}$  and  $V_{FM}<5.0\text{V}$  for  $V_{BR} \geq 201\text{V}$ .

**»Electrical Characteristics ( $T_A=25^{\circ}\text{C}$  unless otherwise noted)**

Part Number (Uni)	Part Number (Bi)	Marking Code		Reverse Stand off Voltage $V_R$ (V)	Breakdown Voltage $V_{BR} @ I_T$ (V)		Test Current $I_T$ (mA)	Maximum Clamping Voltage $V_C @ I_{PP}$ (V)	Maximum Peak Pulse Current $I_{PP}$ (A)	Maximun Reverse Leakage $I_R @ V_R$ ( $\mu\text{A}$ )
		Uni	Bi		Min	Max				
P6SMBJ6.8A	P6SMBJ6.8CA	6V8A	6V8C	5.8	6.45	7.14	10	10.5	58.1	1000
P6SMBJ7.5A	P6SMBJ7.5CA	7V5A	7V5C	6.4	7.13	7.88	10	11.3	54	500
P6SMBJ8.2A	P6SMBJ8.2CA	8V2A	8V2C	7.02	7.79	8.61	10	12.1	50.4	200
P6SMBJ9.1A	P6SMBJ9.1CA	9V1A	9V1C	7.78	8.65	9.55	1	13.4	45.5	50
P6SMBJ10A	P6SMBJ10CA	10A	10C	8.55	9.5	10.5	1	14.5	42.1	10
P6SMBJ11A	P6SMBJ11CA	11A	11C	9.4	10.5	11.6	1	15.6	39.1	5
P6SMBJ12A	P6SMBJ12CA	12A	12C	10.2	11.4	12.6	1	16.7	36.5	5
P6SMBJ13A	P6SMBJ13CA	13A	13C	11.1	12.4	13.7	1	18.2	33.5	1
P6SMBJ15A	P6SMBJ15CA	15A	15C	12.8	14.3	15.8	1	21.2	28.8	1
P6SMBJ16A	P6SMBJ16CA	16A	16C	13.6	15.2	16.8	1	22.5	27.1	1
P6SMBJ18A	P6SMBJ18CA	18A	18C	15.3	17.1	18.9	1	25.5	24.2	1
P6SMBJ20A	P6SMBJ20CA	20A	20C	17.1	19	21	1	27.7	22	1
P6SMBJ22A	P6SMBJ22CA	22A	22C	18.8	20.9	23.1	1	30.6	19.9	1
P6SMBJ24A	P6SMBJ24CA	24A	24C	20.5	22.8	25.2	1	33.2	18.4	1
P6SMBJ27A	P6SMBJ27CA	27A	27C	23.1	25.7	28.4	1	37.5	16.3	1
P6SMBJ30A	P6SMBJ30CA	30A	30C	25.6	28.5	31.5	1	41.4	14.7	1
P6SMBJ33A	P6SMBJ33CA	33A	33C	28.2	31.4	34.7	1	45.7	13.3	1
P6SMBJ36A	P6SMBJ36CA	36A	36C	30.8	34.2	37.8	1	49.9	12.2	1
P6SMBJ39A	P6SMBJ39CA	39A	39C	33.3	37.1	41	1	53.9	11.3	1
P6SMBJ43A	P6SMBJ43CA	43A	43C	36.8	40.9	45.2	1	59.3	10.3	1

**»Electrical Characteristics ( $T_A=25^\circ\text{C}$  unless otherwise noted)**

Part Number (Uni)	Part Number (Bi)	Marking Code		Reverse Stand off Voltage $V_R$ (V)	Breakdown Voltage $V_{BR} @ I_T$ (V)		Test Current $I_T$ (mA)	Maximum Clamping Voltage $V_C @ I_{PP}$ (V)	Maximum Peak Pulse Current $I_{PP}$ (A)	Maximun Reverse Leakage $I_R @ V_R$ ( $\mu\text{A}$ )
		Uni	Bi		Min	Max				
P6SMBJ47A	P6SMBJ47CA	47A	47C	40.2	44.7	49.4	1	64.8	9.4	1
P6SMBJ51A	P6SMBJ51CA	51A	51C	43.6	48.5	53.6	1	70.1	8.7	1
P6SMBJ56A	P6SMBJ56CA	56A	56C	47.8	53.2	58.8	1	77	7.9	1
P6SMBJ58A	P6SMBJ58CA	58A	58C	52.78	55.1	60.9	1	79.8	7.7	1
P6SMBJ62A	P6SMBJ62CA	62A	62C	53	58.9	65.1	1	85	7.2	1
P6SMBJ68A	P6SMBJ68CA	68A	68C	58.1	64.6	71.4	1	92	6.6	1
P6SMBJ75A	P6SMBJ75CA	75A	75C	64.1	71.3	78.8	1	103	5.9	1
P6SMBJ82A	P6SMBJ82CA	82A	82C	70.1	77.9	86.1	1	113	5.4	1
P6SMBJ91A	P6SMBJ91CA	91A	91C	77.8	86.5	95.5	1	125	4.9	1
P6SMBJ100A	P6SMBJ100CA	100A	100C	85.5	95	105	1	137	4.5	1
P6SMBJ110A	P6SMBJ110CA	110A	110C	94	105	116	1	152	4	1
P6SMBJ120A	P6SMBJ120CA	120A	120C	102	114	126	1	165	3.7	1
P6SMBJ130A	P6SMBJ130CA	130A	130C	111	124	137	1	179	3.4	1
P6SMBJ150A	P6SMBJ150CA	150A	150C	128	143	158	1	207	2.9	1
P6SMBJ160A	P6SMBJ160CA	160A	160C	136	152	168	1	219	2.8	1
P6SMBJ170A	P6SMBJ170CA	170A	170C	145	162	179	1	234	2.6	1
P6SMBJ180A	P6SMBJ180CA	180A	180C	154	171	189	1	246	2.5	1
P6SMBJ200A	P6SMBJ200CA	200A	200C	171	190	210	1	274	2.2	1
P6SMBJ220A	P6SMBJ220CA	220A	220C	185	209	231	1	328	1.9	1
P6SMBJ250A	P6SMBJ250CA	250A	250C	214	237	263	1	344	1.8	1
P6SMBJ300A	P6SMBJ300CA	300A	300C	256	285	315	1	414	1.5	1
P6SMBJ350A	P6SMBJ350CA	350A	350C	300	332	368	1	482	1.3	1
P6SMBJ400A	P6SMBJ400CA	400A	400C	342	380	420	1	548	1.1	1
P6SMBJ440A	P6SMBJ440CA	440A	440C	376	418	462	1	602	1	1
P6SMBJ480A	P6SMBJ480CA	480A	480C	408	456	504	1	658	0.9	1
P6SMBJ510A	P6SMBJ510CA	510A	510C	434	485	535	1	698	0.9	1
P6SMBJ530A	P6SMBJ530CA	530A	530C	477	503.5	556.5	1	725	0.8	1
P6SMBJ540A	P6SMBJ540CA	540A	540C	486	513	567	1	740	0.8	1
P6SMBJ550A	P6SMBJ550CA	550A	550C	495	522.5	577.5	1	760	0.8	1

»Rating And Characteristic Curves ( $T_A=25^\circ\text{C}$  unless otherwise noted)

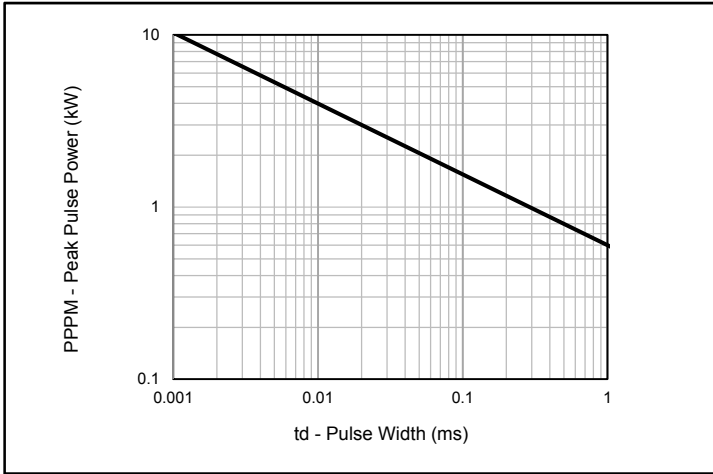

Fig.1 - Peak Pulse Power Rating

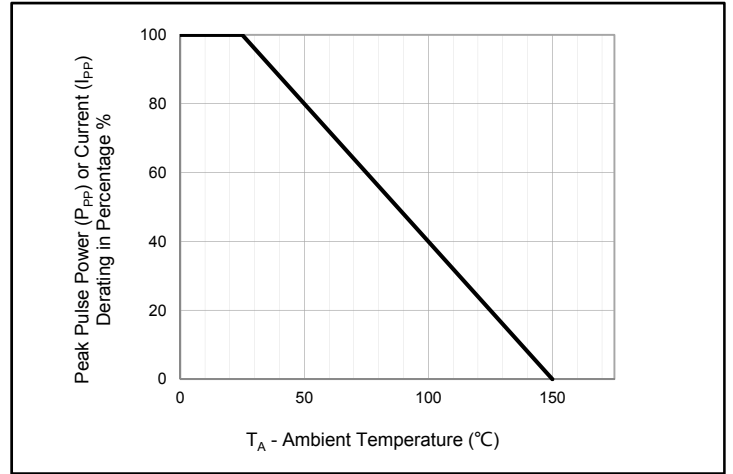

Fig.2 - Pulse Derating Curve

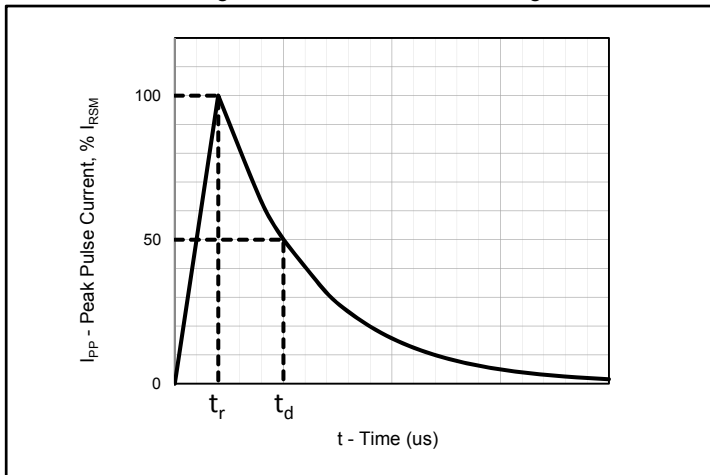

Fig.3 - Pulse Waveform

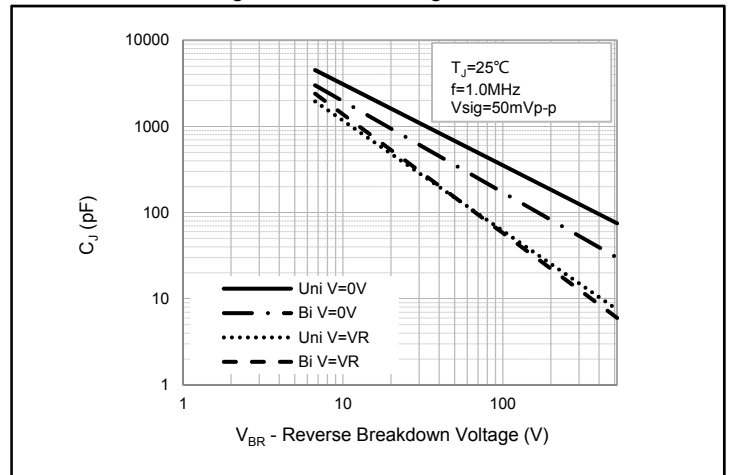

Fig.4 - Typical Junction Capacitance

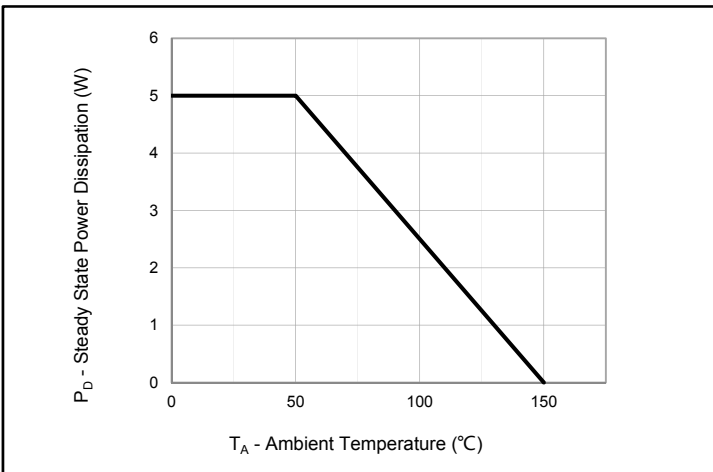

Fig.5 - Steady State Power Dissipation Derating Curve

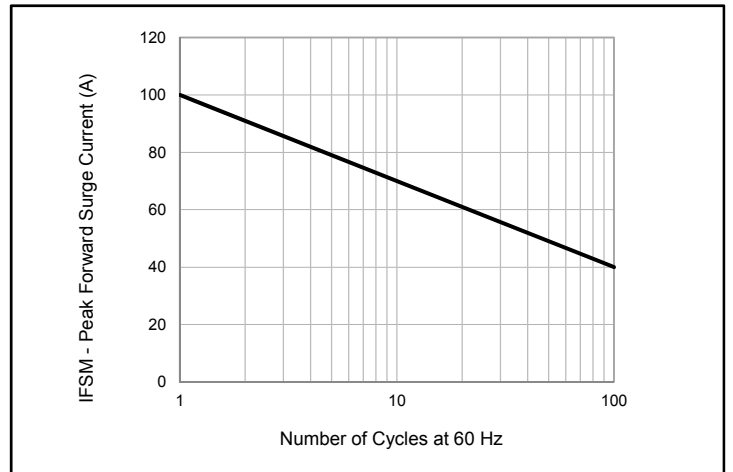
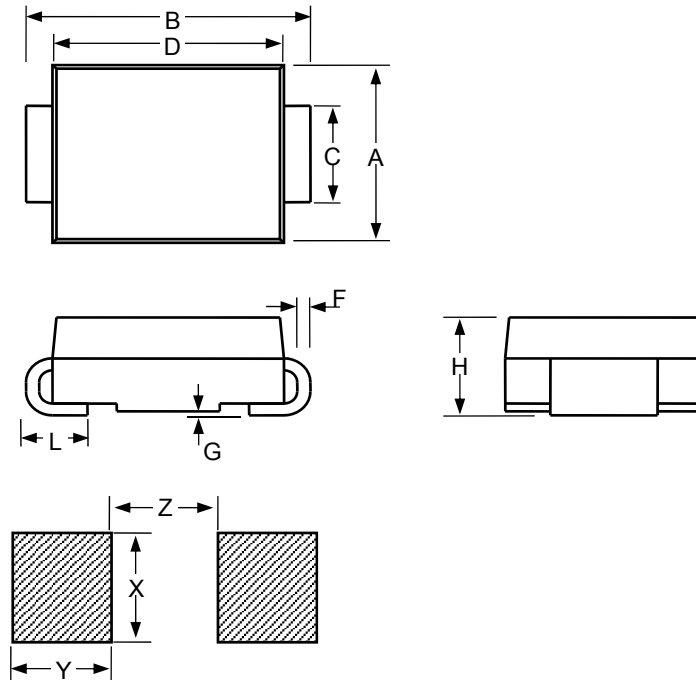

Fig.6 - Maximum Non-Repetitive Peak Forward Surge Current  
Uni-Directional Only

»Package Dimensions



SMB						
Dimension	Inches			Millimeters		
	MIN	NOM	MAX	MIN	NOM	MAX
A	0.134	0.144	0.155	3.4	3.67	3.94
B	0.205	0.213	0.22	5.21	5.4	5.59
C	0.075	0.079	0.083	1.9	2	2.1
D	0.169		0.185	4.3		4.7
F	0.006		0.012	0.152		0.305
G	-		0.008	-		0.203
H	0.085	0.091	0.096	2.15	2.3	2.45
L	0.03		0.06	0.76		1.52
X		0.11			2.8	
Y		0.079			2	
Z		0.079			2	

»Marking Information

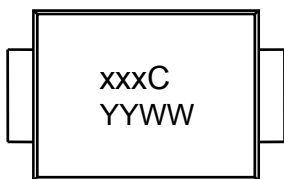

xxxC = Type Code  
YYWW = Date Code

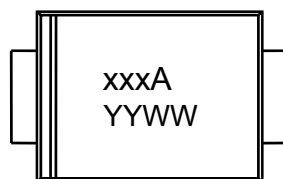

xxxA = Type Code  
YYWW = Date Code

»Soldering Parameters

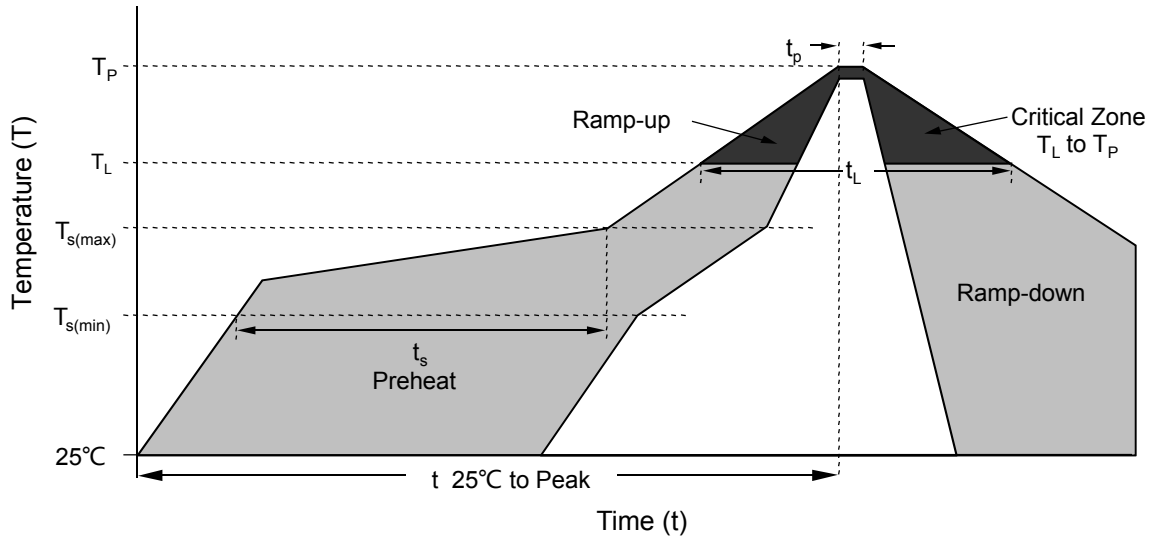

Reflow Condition		Lead-free assembly
Pre Heat	- Temperature Min ( $T_{s(min)}$ )	150°C
	- Temperature Max ( $T_{s(max)}$ )	200°C
	- Time (min to max) ( $t_s$ )	60 – 180 secs
Average ramp up rate (Liquidus Temp ( $T_L$ ) to peak)		3°C/second max
$T_{s(max)}$ to $T_L$ - Ramp-up Rate		3°C/second max
Reflow	- Temperature ( $T_L$ ) (Liquidus)	217°C
	- Time ( $t_L$ )	60 – 150 secs
Peak Temperature ( $T_P$ )		260 <sup>+0/-5</sup> °C
Time within 5°C of actual peak Temperature ( $t_p$ )		20 – 40 secs
Ramp-down Rate		6°C/second max
Time 25°C to peak Temperature (t)		8 minutes Max.
Do not exceed		260°C

»Tape and Reel Specification

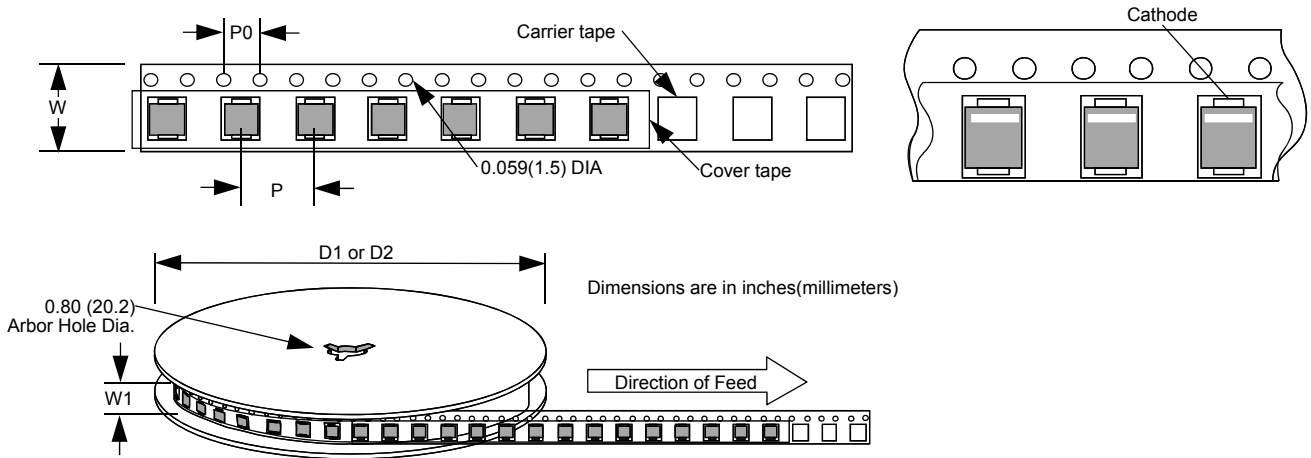

Dimension	Inches			Millimeters		
	MIN	NOM	MAX	MIN	NOM	MAX
P		0.315			8	
P0		0.157			4	
W		0.472			12	
W1		0.492			12.5	
D1		7			177.8	
D2		13			330.2	