

# HSP

**NOTES:**

Current Rating: 3.0AMP  
 Contact Resistance: 20m Ω Max  
 Withstand Voltage: 1000V AC/minute  
 Insulation Resistance: 1000M Ω Min  
 Operation Temperature: -40°C to +105°C

Contact Material: Brass  
 Contact plating: Au Or Sn Over Ni  
 Insulator Material: PA46 Or PA66 (UL94V-0)

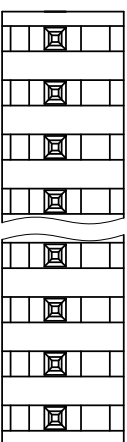
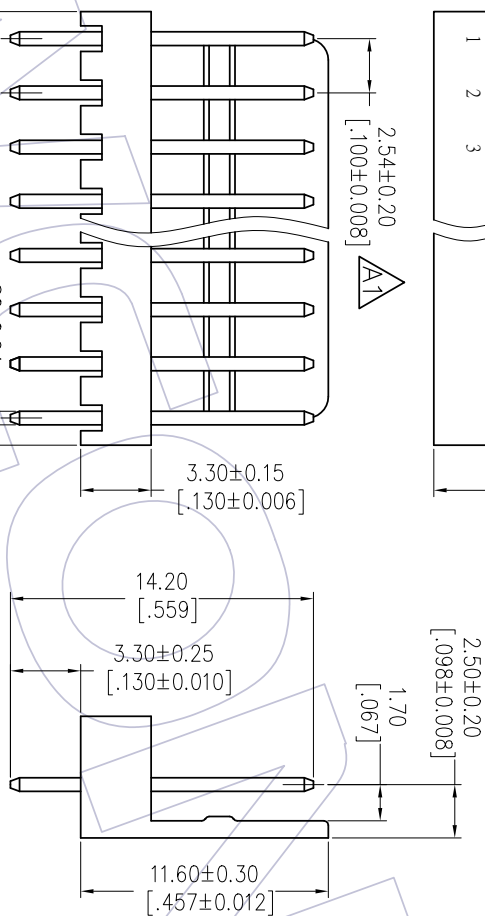
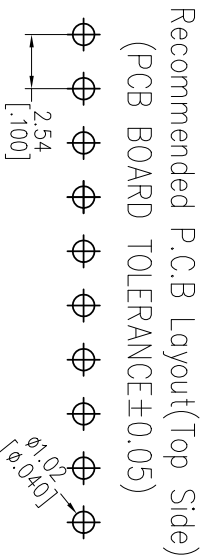
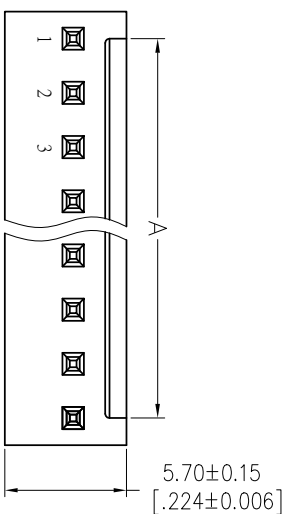

## Ordering Information

WF2541-WS XX E 0 1

No. of pins Contact Plating Color Packing  
 02-20P SO=Gold Flash/Tin B=Black 0=PE Bag  
 S3=10u"Gold/Tin E=Beige  
 S4=15u"Gold/Tin T=Natural  
 S5=30u"Gold/Tin  
 H=P=PA46  
 Blank=P=PA66  
 C0=Gold Flash  
 G3=10u"Gold  
 G4=15u"Gold  
 G5=30u"Gold  
 Blank=Tin

### Specification & Ordering Information:

Circuit	Part No.	Dimension		QTY/ bag
		A	B	
02	WF2541-WS(X)02XXX01	2.54	5.08	1,000
03	WF2541-WS(X)03XXX01	5.08	7.62	1,000
04	WF2541-WS(X)04XXX01	7.62	10.16	1,000
05	WF2541-WS(X)05XXX01	10.16	12.70	1000
06	WF2541-WS(X)06XXX01	12.70	15.24	500
07	WF2541-WS(X)07XXX01	15.24	17.78	500
08	WF2541-WS(X)08XXX01	17.78	20.32	500
09	WF2541-WS(X)09XXX01	20.32	22.86	400
10	WF2541-WS(X)10XXX01	22.86	25.40	400
11	WF2541-WS(X)11XXX01	25.40	27.94	300
12	WF2541-WS(X)12XXX01	27.94	30.48	300
13	WF2541-WS(X)13XXX01	30.48	33.02	300
14	WF2541-WS(X)14XXX01	33.02	35.56	300
15	WF2541-WS(X)15XXX01	35.56	38.10	200
16	WF2541-WS(X)16XXX01	38.10	40.64	200
17	WF2541-WS(X)17XXX01	40.64	43.18	200
18	WF2541-WS(X)18XXX01	43.18	45.72	200
19	WF2541-WS(X)19XXX01	45.72	48.26	200
20	WF2541-WS(X)20XXX01	48.26	50.80	200

REV	DATE	MODIFICATION DESCRIPTION	CHANGE	OPERATION		DRAW		SCALE		FIT		PART NO.
				XX	±0.40	Du Ymg	DATE	UNIT	mm	PROJ.		
A1	2020/05/05	Add Dimension	Du Ymg	X.XX	±0.25	CHECK	DATE	A4	1/1	SEE TAB		
AO	2012/09/08	NEW	JYHuang	X.XXX	±0.15	APPROVE	DATE	1/1	TITLE: "W" TYPE 2.54 Wafer 180°			
				Angle	± 3°				Customer NO.			

# WCON

Http: www.wcon.com

WCON-Dongguan Tel: +86 769 85358920  
 WCON-Kunshan Tel: +86 512 57468408  
 Tel: +86 769 85358920  
 Fax: +86 769 85358915  
 E-mail: sales@wcon.com  
 Fax: +86 512 57468468  
 E-mail: sales@wcon.com