

修订 REV	标记 MARK	修改摘要 REVISION DESCRIPTION	签名 SIGNATURE	日期 DATE
A0		NEW DWG		2014-05-07

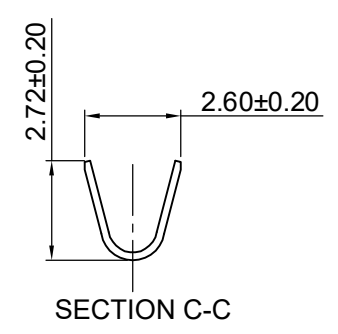
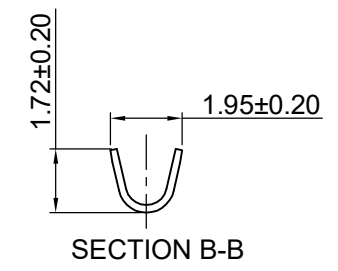
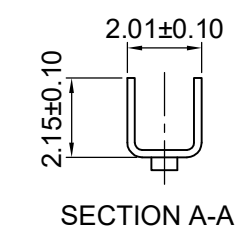
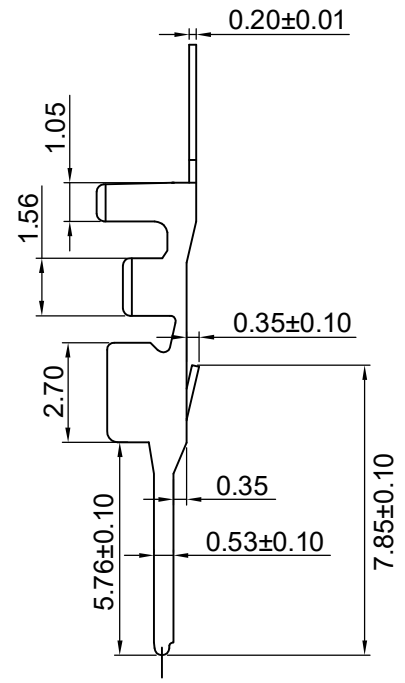
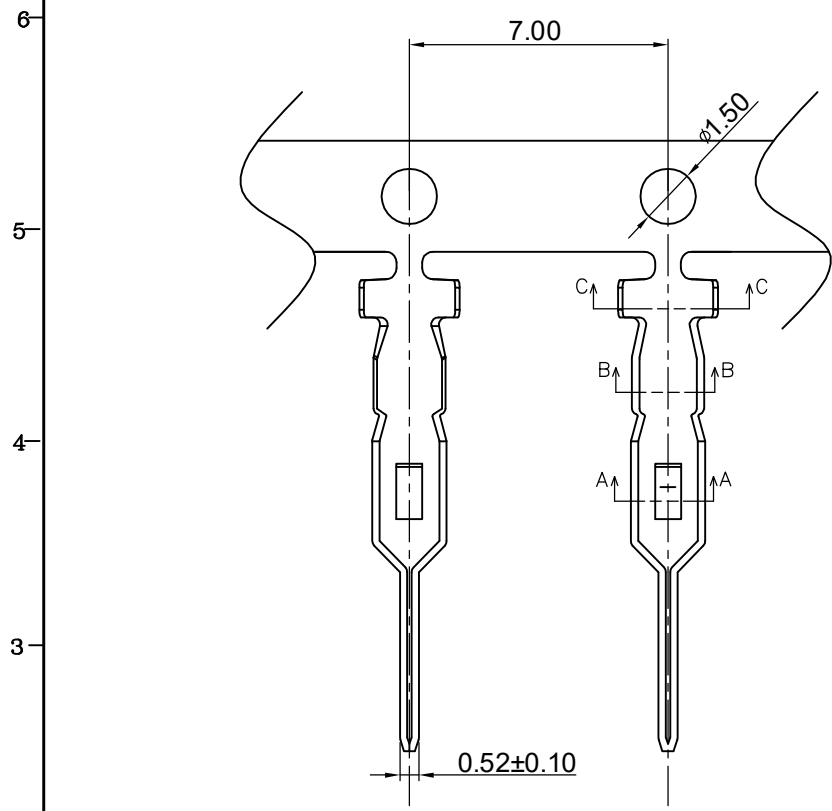

- 技术要求:
- 1、表面无垫伤、毛刺、变形，无明显划痕、斑点、花纹；
  3. 材质：黄铜 H65，T=0.20±0.01MM.

 深圳市华德共创科技有限公司 Shenzhen Huade co-create Technology Co.,LTD 电话：0755-27129737 传真：0755-29940187		TITLE: <b>BH3.5(公)-TER</b> 产品名称:				
		PART NO: <b>HDGC3500M-T</b> 产品编号:				
X.X ±0.30 X.XX ±0.30 X.XXX ±0.10	X.X' ±3' X.XX' ±2' X.XXX' ±1'	APPD: 核准: 谢亮 CHECK: 校对: 王建业 DRAW: 绘图: 黄艳兰	DATE	SCALE	UNIT	CODE NUMBER
			2014-05-07	1:1	mm	A001