

修订 REV	标记 MARK	修改摘要 REVISION DESCRIPTION	签名 SIGNATURE	日期 DATE
AO		NEW DWG		2013-07-05

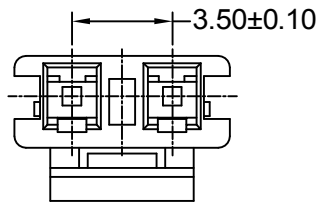
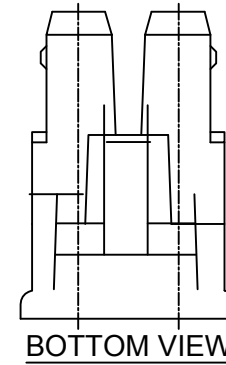
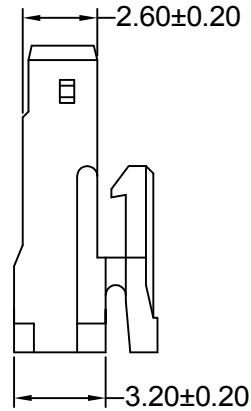
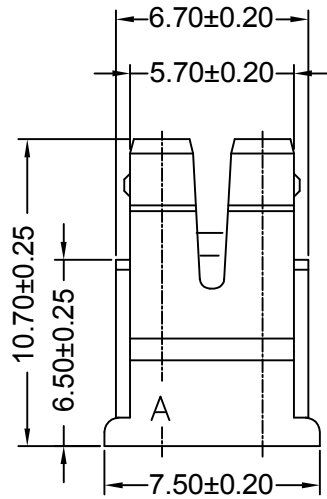

产品要求

- 1、材质：白色PA66 UL94-V0；
- 2、尺寸：所有尺寸均符合检测标准。

		深圳市华德共创科技有限公司 Shenzhen Huade co-create Technology Co.,LTD 电话：0755-27129737 传真：0755-29940187						
		-TOLERANCES- UNLESS OTHERWISE SPECIFIED 公差参数表				TITLE: 产品名称: BH3.5(公)-H 带扣		
X.X	±0.30	X.X'	±3'	APPD: 核准: 谢亮	PART NO: 产品编号: HDGC3500HA-2P			
X.XX	±0.30	X.XX'	±2'	CHECK: 校对: 王建业	DATE	SCALE	UNIT	CODE NUMBER
X.XXX	±0.10	X.XXX'	±1'	DRAW: 绘图: 黄艳兰	2013-07-05	1:1	mm	A001

修订 REV	标记 MARK	修改摘要 REVISION DESCRIPTION	签名 SIGNATURE	日期 DATE
A0		NEW DWG		2013-05-12

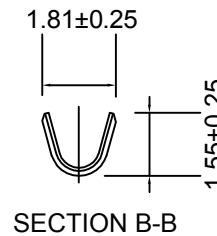
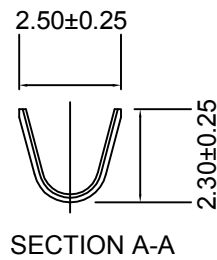
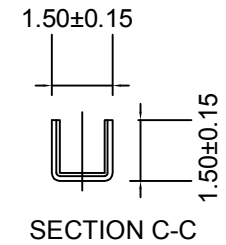
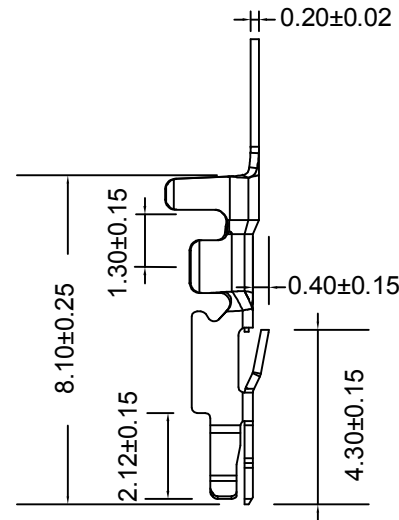
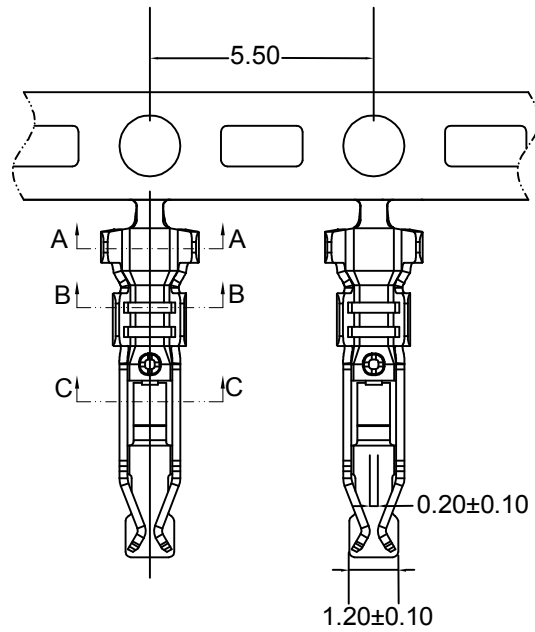

Ordering Information & Specifications

Part NO	Wire Range	Insulation O.D	Material	Finish	Qty/reel
HDGC3500-T	AWG#24-#28	1.6mm(max)	Phosphor Bronze	Tin-plated	15,000pcs

产品要求:

1. 材质要求: 磷铜, C5191 (T=0.20±0.02MM);
2. 电镀要求: 先冲后镀, 镀全锡, Ni底;



深圳市华德共创科技有限公司
Shenzhen Huade co-create Technology Co., LTD
电话: 0755-27129737 传真: 0755-29940187

-TOLERANCES-
UNLESS OTHERWISE SPECIFIED
公差参数表

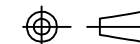

TITLE: BH3.5(母)-TER
产品名称:

X.X	±0.30	X.X'	±3'	APPD: 核准: 谢亮	PART NO: 产品编号: HDGC3500-T			
X.XX	±0.30	X.XX'	±2'	CHECK: 校对: 王建业	DATE	SCALE	UNIT	CODE NUMBER
X.XXX	±0.10	X.XXX'	±1'	DRAW: 绘图: 黄艳兰	2013-05-12	1:1	mm	A001