

修订 REV	标记 MARK	修改摘要 REVISION DESCRIPTION	签名 SIGNATURE	日期 DATE
A0		NEW DWG		2018-07-25

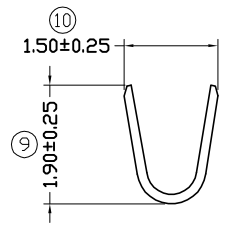

SECTION A-A

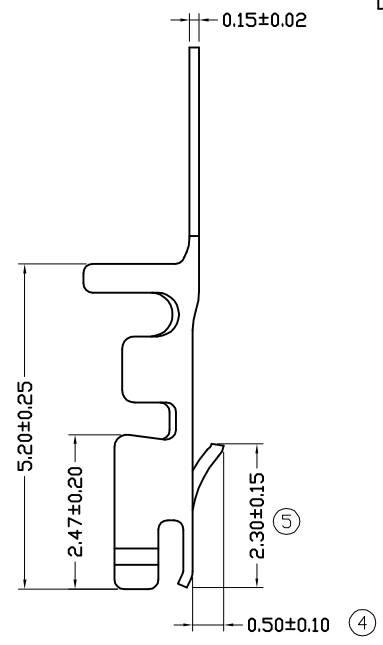
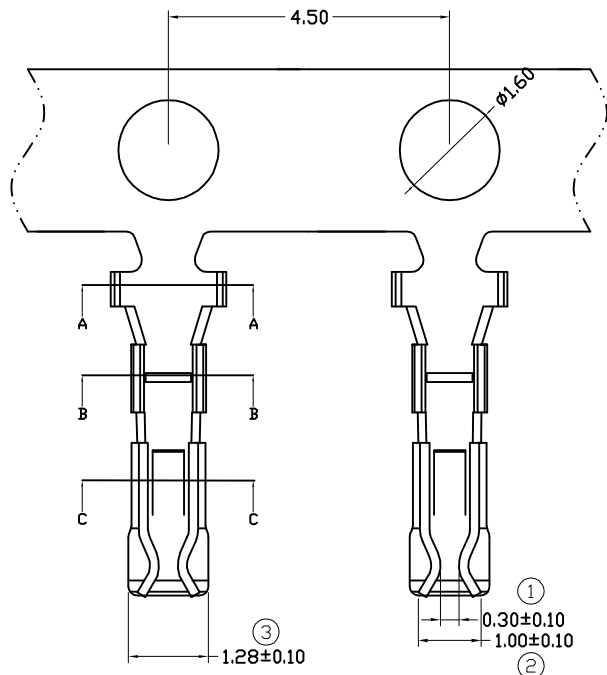
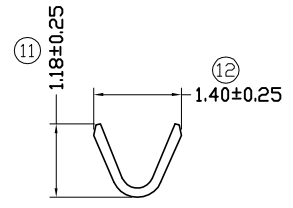

SECTION B-B

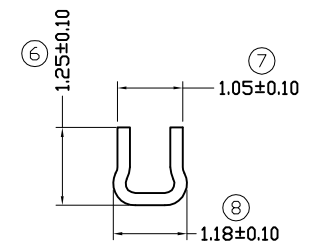

SECTION C-C

Part NO.	Wire Range	Insulation O.D.	Material	Finish	Qty/reel
HDGC1802-T	AWG#18-#24	2.70mm(max)	Phosphor Bronze	Tin over Nickel	20,000PCS

		深圳市华德共创科技有限公司 Shenzhen Huade co-create Technology Co.,LTD 电话：0755-27129737 传真：0755-29940187						
-TOLERANCES- UNLESS OTHERWISE SPECIFIED 公差参数表				TITLE: 产品名称: 1.8连接器				
X.X	± 0.30	X.X'	$\pm 3'$	APPD: 核准: 谢亮	PART NO: 产品编号: HDGC1801-T			
X.XX	± 0.30	X.XX'	$\pm 2'$	CHECK: 校对: 王建业	DATE	SCALE	UNIT	CODE NUMBER
X.XXX	± 0.10	X.XXX'	$\pm 1'$	DRAW: 绘图: 黄艳兰	2018-07-25	1:1	mm	A001