

修订 REV	标记 MARK	修改摘要 REVISION DESCRIPTION	签名 SIGNATURE	日期 DATE
AO		NEW DWG		2019-10-08

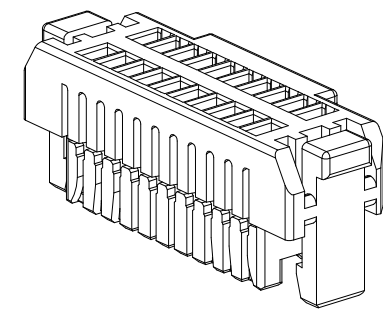

PIN	Dimensions	
	A	B
2X4P		9.70
2X5P	4.00	10.70
2X6P	5.00	11.70
2X7P	6.00	12.70
2X8P	7.00	13.70
2X10P	9.00	15.70
2X12P	11.00	17.70
2X15P	14.00	20.70
2X20P	19.00	25.70
2X25P	24.00	30.70

材质：PA66，颜色：本色

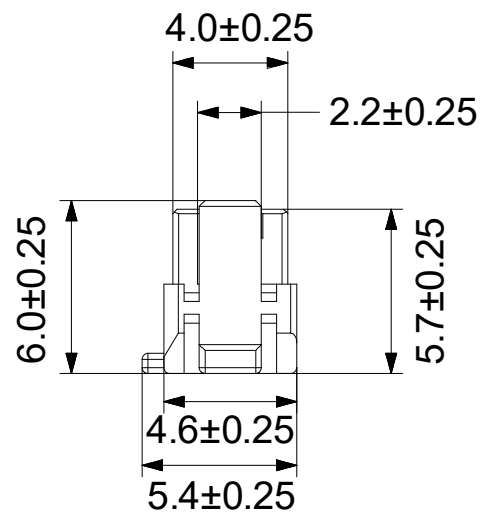
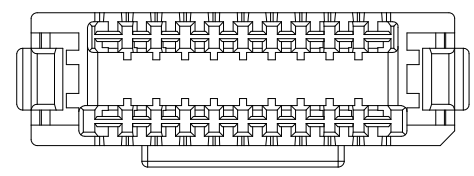
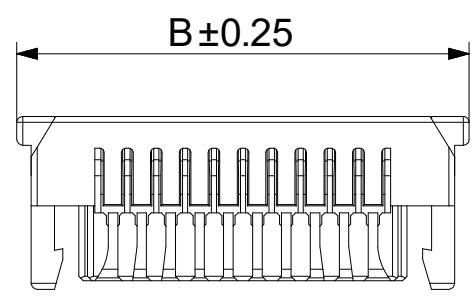
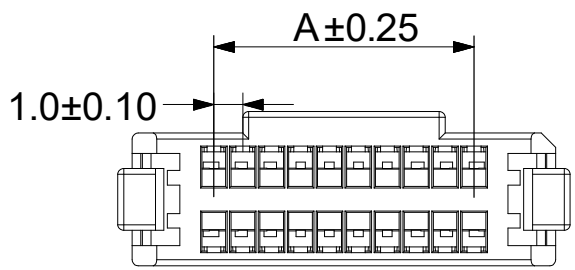

深圳市华德共创科技有限公司  
Shenzhen Huade co-create Technology Co.,LTD  
电话：0755-27129737 传真：0755-29940187

-TOLERANCES- UNLESS OTHERWISE SPECIFIED 公差参数表				TITLE: 产品名称: SHLP1.0胶壳				
X.X	±0.30	X.X*	±3'	APPD: 核准: 谢亮	PART NO: 产品编号: HDGC1006H-2xXP			
X.XX	±0.30	X.XX*	±2'	CHECK: 校对: 王建业	DATE	SCALE	UNIT	CODE NUMBER
X.XXX	±0.10	X.XXX*	±1'	DRAW: 绘图: 黄艳兰	2019-10-08	4:1	mm	A001

修订 REV	标记 MARK	修改摘要 REVISION DESCRIPTION	签名 SIGNATURE	日期 DATE
AO		NEW DWG		2015-12-21

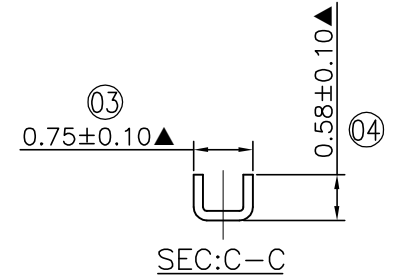
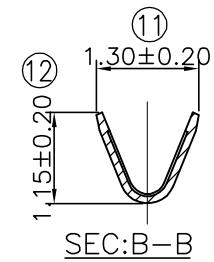
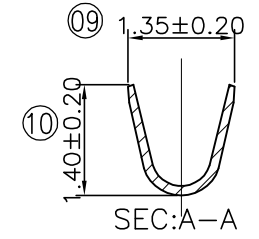
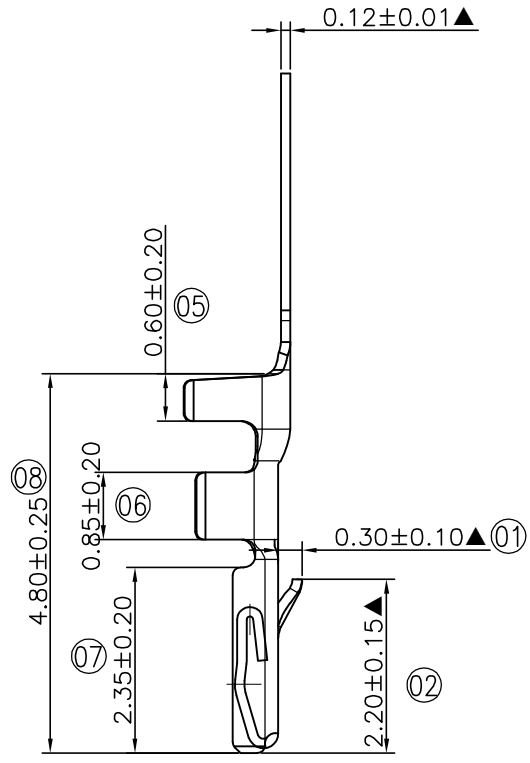
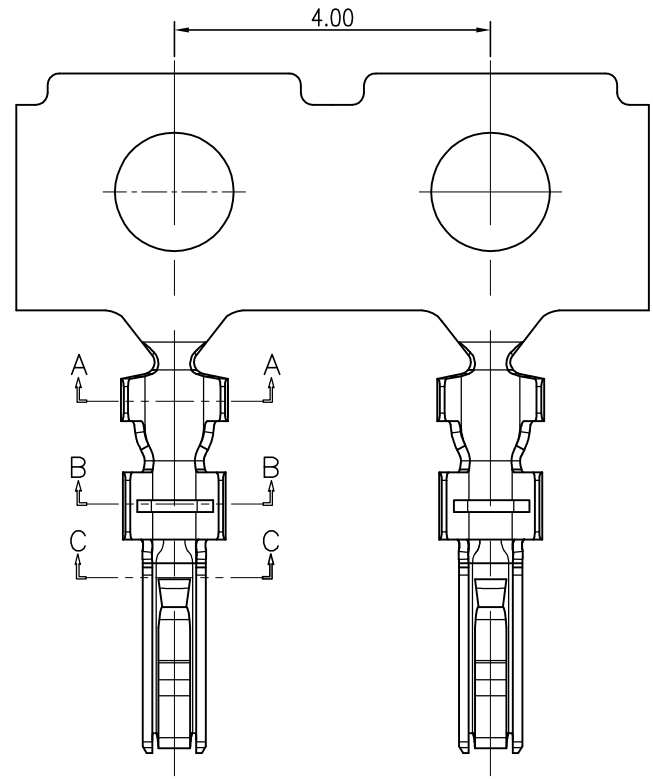

产品要求:

1. 材质:C5191 (T=0.12mm);
2. 电镀标准:先冲后镀 镀全锡 Ni底;
3. 包装标准:每盘20000PCS;
4. ▲为重点检验尺寸;



深圳市华德共创科技有限公司  
Shenzhen Huade co-create Technology Co.,LTD  
电话: 0755-27129737 传真: 0755-29940187

-TOLERANCES- UNLESS OTHERWISE SPECIFIED 公差参数表		TITLE: 产品名称: SHLPL1.0-TER	
X.X ±0.30	X.X* ±3'	APPD: 核准: 谢亮	PART NO: 产品编号: HDGC1006-T
X.XX ±0.30	X.XX* ±2'	CHECK: 校对: 王建业	DATE
X.XXX ±0.10	X.XXX* ±1'	DRAW: 绘图: 黄艳兰	SCALE
			UNIT
			CODE NUMBER
		2015-12-21	1:1
			mm
			A001