

**Data Sheet**

Customer :

Product Type: SMD NTC Thermistor

Part No.: NTC03T683J410H

Issued Date: 24-May-12

Edition : REV.A-2



VIKING TECH CORPORATION

光頡科技股份有限公司  
No.70, Kuanfu N. Rad.,  
Hsin Chu Industrial Park,  
Hukou Hsiang, Hsin Chu Hsien,  
303, Taiwan  
TEL:886-3-5972931  
FAX:886-3-5972935•886-3-5973494  
E-mail:sales@viking.com.tw

VIKING TECH CORPORATION KAOHSIUNG BRANCH

光頡科技股份有限公司高雄分公司  
No.248-3, Sin-Sheng Rd., Cian-Jhen Dist., Kaohsiung,  
806, Taiwan  
TEL:886-7-8217999  
FAX:886-7-8228229  
E-mail:sales@viking.com.tw

WUXI TMTEC CO., LTD.

無錫泰銘電子有限公司  
No.1A,(Xixia Road),Machinery & industry Park,  
National Hi-Tech Industries Development Zone of  
Wuxi, Wuxi, Jiangsu Province, China  
Zip Code:214028  
TEL:86-510-85203339  
FAX:86-510-85203667•86-510-85203977  
E-mail:wuxisales@tmtec.com.tw

Produced by (QC)	Checked (QC)	Approved by (QC)	Prepared by (Sales)	Accepted by (Customer)
24-May-12	24-May-12	24-May-12	24-May-12	
<b>Kris</b>	<b>Ann</b>	<b>Ben</b>		

## SMD NTC Thermistor

(NTC03T683J410H)

### ■ Dimensions

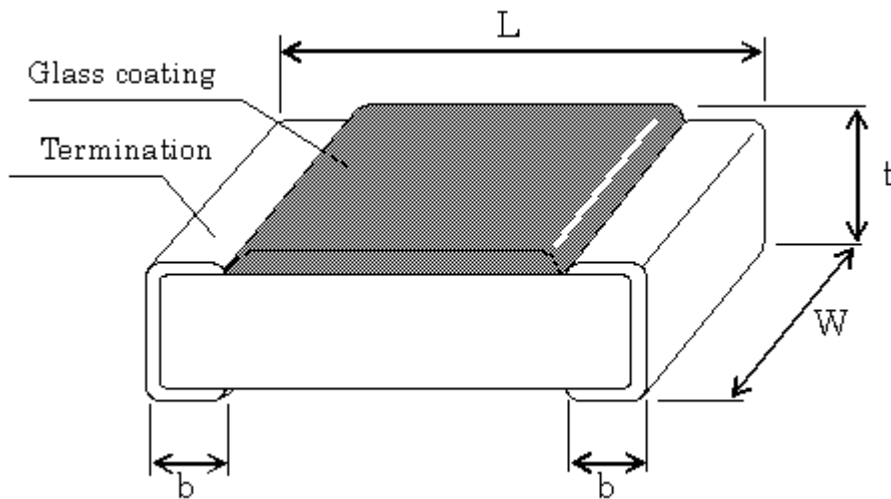

Unit: mm

Type	Size	L	W	t	b
NTC03	0603	1.6±0.15	0.8±0.15	0.5±0.10	0.3±0.20

### ■ Part Numbering

NTC	03	T	683	J	410	H
Product Type	Dimensions (L×W)	Packaging Code	Resistance (25°C)	Resistance Tolerance	B-Constant	B-Constant Tolerance
	03: 0603	T: Taping Reel	683: 68KΩ	J: ±5%	410: 4100K	H: 3%

## ■ Electrical Characteristics

Item	Specification
Rated Zero-power Resistance	R=68KΩ±5% (at 25°C)
B Constant	B <sub>25/85</sub> =4100K±3% The B constant is calculated using the zero-power resistance values measured at 25°C and 85°C
Dissipation Constant	1.2 mW/°C (in air)
Thermal Time Constant	≤2 sec (in still air)
Rated Power	5 mW
Operating Temperature	-40°C ~ 125°C

## ■ IR Reflow

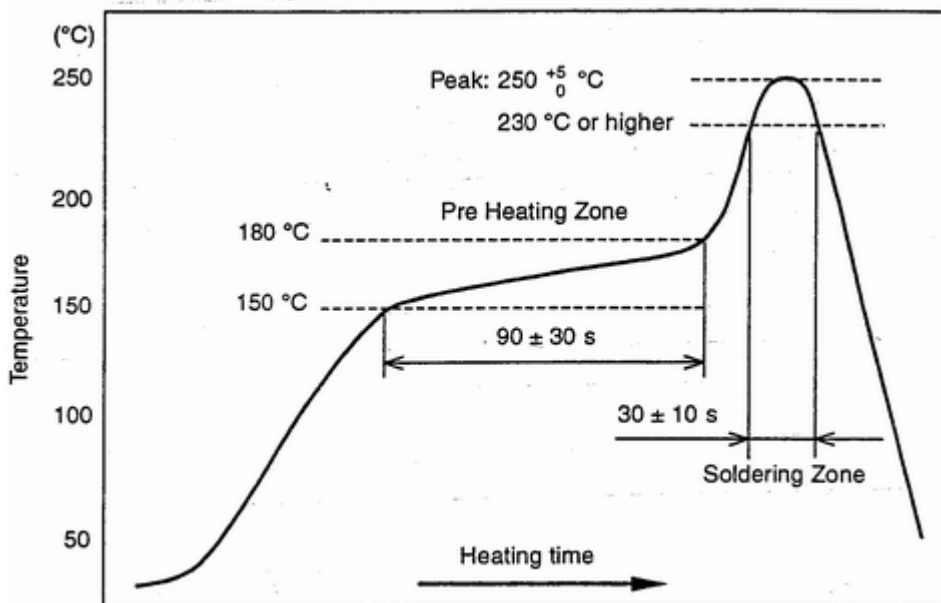

## ■ Environmental Characteristics

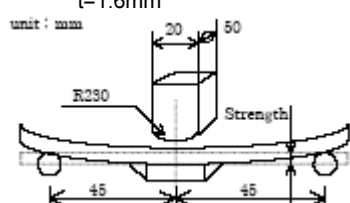
Item	Conditions	Performances
Stability	(125±3°C) × (1000+48)hrs	△ R <sub>25</sub> / R <sub>25</sub> ≤ ±3% △ B / B ≤ ±2%
Low Temperature	(-40±3°C) × (1000+48)hrs	△ R <sub>25</sub> / R <sub>25</sub> ≤ ±3% △ B / B ≤ ±2%
Humidity	85±2°C, 85±5%RH × (1000+48) hrs	△ R <sub>25</sub> / R <sub>25</sub> ≤ ±3% △ B / B ≤ ±2%
Thermal Shock Test	-40±3°C × 30(min) → 25±3°C × 3(min) → 125±3°C × 30(min) → 25±3°C × 3(min) 100cycles	△ R <sub>25</sub> / R <sub>25</sub> ≤ ±3% △ B / B ≤ ±2%
Load Humidity	85±2°C, 85±5%RH, rated power 90 mins on, 30 mins off for (1000+48) hrs	△ R <sub>25</sub> / R <sub>25</sub> ≤ ±3% △ B / B ≤ ±2%
Resistance to Soldering Heat Test	Soldering temperature : 260±5°C Duration of immersion : 10 ± 1 sec.	△ R <sub>25</sub> / R <sub>25</sub> ≤ ±3% No mechanical damage
Solderability Test	Soldering temperature : 245±5°C Duration of immersion : 3 ± 0.5 sec. Preparation : Immersion in flux for 1~2 secs. Flux : rosin : methanol = 25wt% : 75wt% Solder : Sn-3.0Ag-0.5Cu	At least 95% of the electrode on each end of the ceramic chip must be covered with new solder
Solder Iron Test	The inspected unit is tested by solder iron under 380±10°C with 5±1 sec	△ R <sub>25</sub> / R <sub>25</sub> ≤ ±3% △ B / B ≤ ±3%
Substrate Bending	Applied bending : 5mm Holding time : 10±1 secs Substrate : glass fiber base epoxy resin t=1.6mm unit : mm 	△ R <sub>25</sub> / R <sub>25</sub> ≤ ±3% No mechanical damage
Vibration	Applied frequency : 10~55~10Hz / 1min Amplitude : 1.5mm in each X,Y,Z directions Applied time : 2 hrs in each X,Y,Z directions	△ R <sub>25</sub> / R <sub>25</sub> ≤ ±3% No mechanical damage

■ Storage Temperature: 15~35°C; Humidity 25%~85%RH

## ■ Packaging

### Reel Specifications & Packaging Quantity

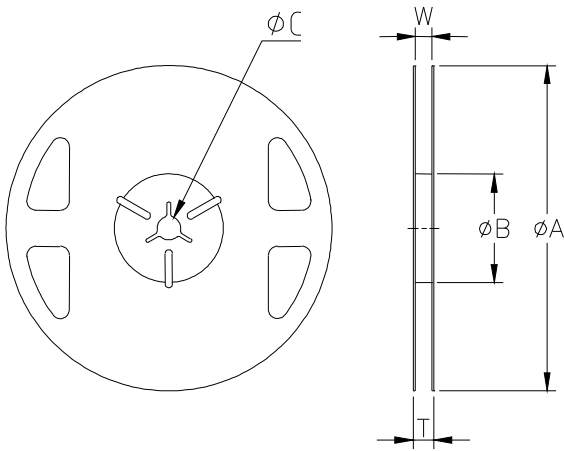

Unit: mm

Type	$\Phi A$	$\Phi B$	$\Phi C$	W	T	Packaging
						Quality
NTC03	180+0/-3	60+1/-0	13.0±0.2	9.0±0.3	11.4±1.0	5K

### Paper Tape Specifications

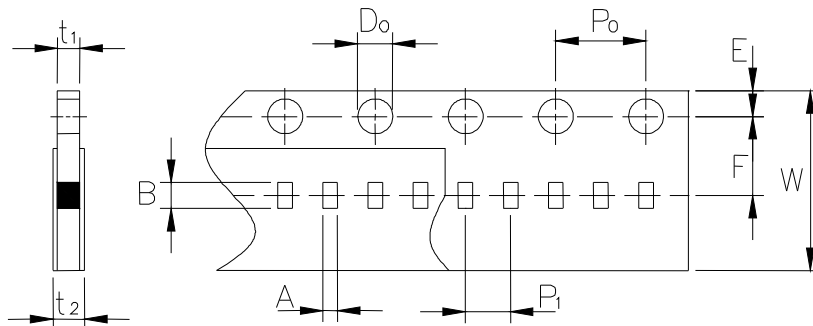

Unit: mm

Type	A	B	W	F	E	$P_1$	$P_2$	$P_0$	$\psi D_0$	$t_1$	$t_2$
NTC03	1.1±0.2	1.9±0.2	8.0±0.20	3.5±0.05	1.75±0.1	4.00±0.1	2.00±0.05	4.00±0.1	1.55±0.05	1.0 <sup>+0</sup>	1.4 <sup>+0</sup>

■ R-T Curve

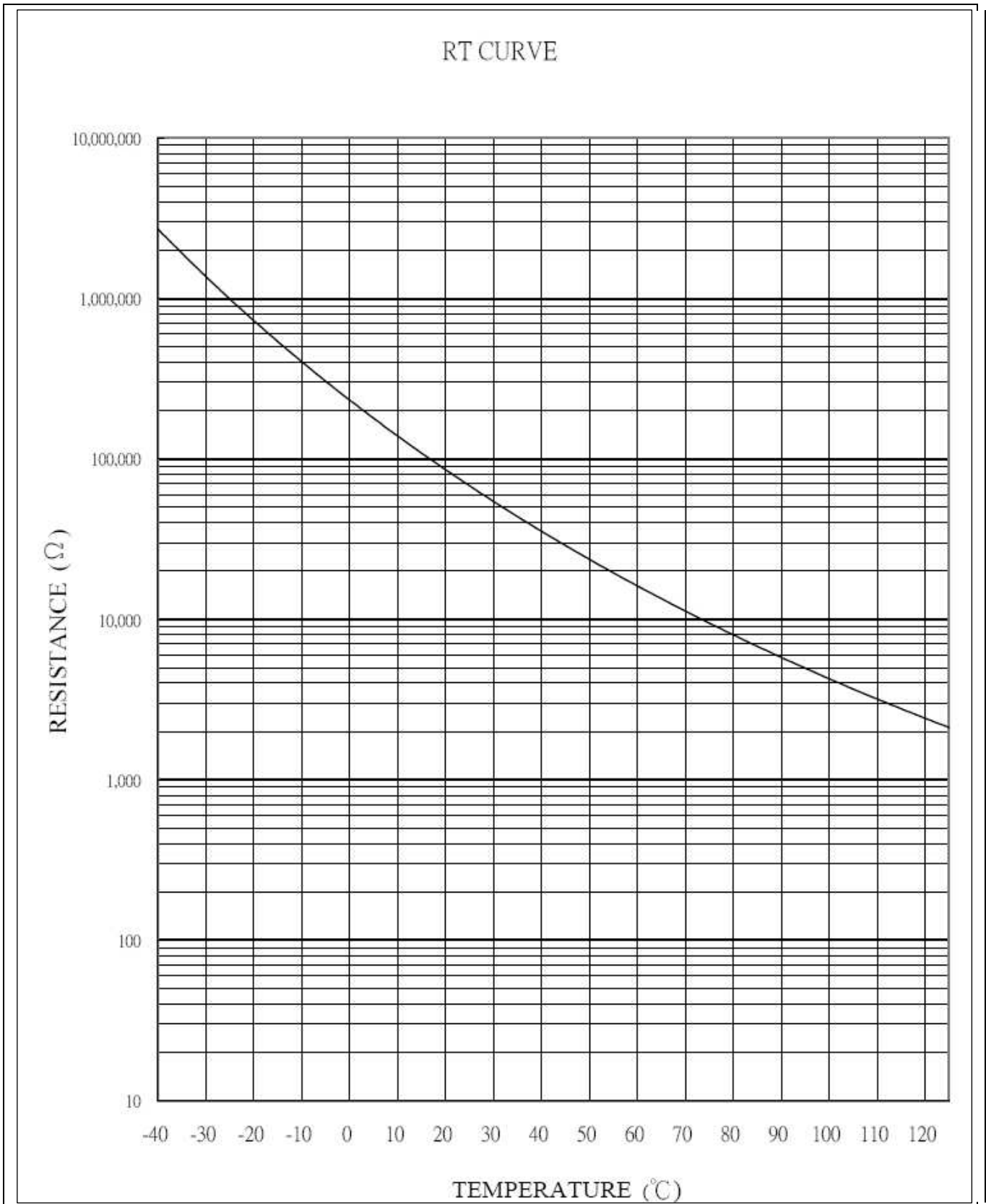

■ R-T Table

RESISTANCE-TEMPERATURE CHARACTERISTICS

R25 = 68000 Ω ± 5%

B25/85 = 4100 K ± 3%

Temp. (°C)	Resistance (Ω)			Temp. Coef.(%/°C)	Resist. Tolerance (%)		Temp. Tolerance (°C)	
	MIN.	CENTER	MAX.		MIN.	MAX.	MIN.	MAX.
-40.0	2217777	2714000	3210223	-7.08	-18.28	18.28	-2.58	2.58
-39.0	2073436	2529311	2985187	-7.02	-18.02	18.02	-2.57	2.57
-38.0	1939455	2358451	2777448	-6.97	-17.77	17.77	-2.55	2.55
-37.0	1815024	2200296	2585568	-6.92	-17.51	17.51	-2.53	2.53
-36.0	1699403	2053819	2408234	-6.87	-17.26	17.26	-2.51	2.51
-35.0	1591914	1918083	2244252	-6.81	-17.00	17.00	-2.50	2.50
-34.0	1491933	1792233	2092532	-6.76	-16.76	16.76	-2.48	2.48
-33.0	1398891	1675486	1952080	-6.71	-16.51	16.51	-2.46	2.46
-32.0	1312262	1567125	1821989	-6.66	-16.26	16.26	-2.44	2.44
-31.0	1231566	1466497	1701428	-6.61	-16.02	16.02	-2.42	2.42
-30.0	1156358	1373000	1589642	-6.57	-15.78	15.78	-2.40	2.40
-29.0	1086178	1286016	1485854	-6.52	-15.54	15.54	-2.38	2.38
-28.0	1020713	1205118	1389523	-6.47	-15.30	15.30	-2.36	2.36
-27.0	959617	1129842	1300067	-6.42	-15.07	15.07	-2.35	2.35
-26.0	902571	1059762	1216954	-6.38	-14.83	14.83	-2.33	2.33
-25.0	849284	994489	1139693	-6.33	-14.60	14.60	-2.31	2.31
-24.0	799485	933662	1067839	-6.29	-14.37	14.37	-2.29	2.29
-23.0	752924	876951	1000978	-6.24	-14.14	14.14	-2.27	2.27
-22.0	709372	824054	938735	-6.20	-13.92	13.92	-2.25	2.25
-21.0	668616	774689	880762	-6.15	-13.69	13.69	-2.23	2.23
-20.0	630460	728600	826740	-6.11	-13.47	13.47	-2.20	2.20
-19.0	594743	685574	776405	-6.07	-13.25	13.25	-2.18	2.18
-18.0	561275	645365	729455	-6.02	-13.03	13.03	-2.16	2.16
-17.0	529901	607771	685642	-5.98	-12.81	12.81	-2.14	2.14
-16.0	500477	572608	644738	-5.94	-12.60	12.60	-2.12	2.12
-15.0	472872	539702	606532	-5.90	-12.38	12.38	-2.10	2.10
-14.0	446961	508896	570831	-5.86	-12.17	12.17	-2.08	2.08
-13.0	422631	480043	537455	-5.82	-11.96	11.96	-2.06	2.06
-12.0	399777	453008	506240	-5.78	-11.75	11.75	-2.03	2.03
-11.0	378300	427666	477032	-5.74	-11.54	11.54	-2.01	2.01
-10.0	358109	403900	449691	-5.70	-11.34	11.34	-1.99	1.99

Temp. (°C)	Resistance ( $\Omega$ )			Temp. Coef.(%/°C)	Resist. Tolerance (%)		Temp. Tolerance (°C)	
	MIN.	CENTER	MAX.		MIN.	MAX.	MIN.	MAX.
-9.0	339119	381603	424087	-5.66	-11.13	11.13	-1.97	1.97
-8.0	321254	360676	400098	-5.62	-10.93	10.93	-1.94	1.94
-7.0	304438	341026	377614	-5.58	-10.73	10.73	-1.92	1.92
-6.0	288606	322569	356532	-5.55	-10.53	10.53	-1.90	1.90
-5.0	273693	305225	336757	-5.51	-10.33	10.33	-1.88	1.88
-4.0	259641	288920	318199	-5.47	-10.13	10.13	-1.85	1.85
-3.0	246396	273586	300777	-5.44	-9.94	9.94	-1.83	1.83
-2.0	233906	259160	284415	-5.40	-9.74	9.74	-1.80	1.80
-1.0	222125	245583	269042	-5.36	-9.55	9.55	-1.78	1.78
0.0	211008	232800	254592	-5.33	-9.36	9.36	-1.76	1.76
1.0	200515	220761	241008	-5.29	-9.17	9.17	-1.73	1.73
2.0	190606	209418	228230	-5.26	-8.98	8.98	-1.71	1.71
3.0	181246	198726	216207	-5.22	-8.80	8.80	-1.68	1.68
4.0	172402	188645	204888	-5.19	-8.61	8.61	-1.66	1.66
5.0	164041	179135	194230	-5.16	-8.43	8.43	-1.63	1.63
6.0	156135	170162	184189	-5.12	-8.24	8.24	-1.61	1.61
7.0	148657	161692	174727	-5.09	-8.06	8.06	-1.58	1.58
8.0	141581	153694	165807	-5.06	-7.88	7.88	-1.56	1.56
9.0	134883	146139	157395	-5.03	-7.70	7.70	-1.53	1.53
10.0	128541	139000	149459	-4.99	-7.52	7.52	-1.51	1.51
11.0	122531	132249	141967	-4.96	-7.35	7.35	-1.48	1.48
12.0	116838	125866	134894	-4.93	-7.17	7.17	-1.45	1.45
13.0	111442	119828	128214	-4.90	-7.00	7.00	-1.43	1.43
14.0	106326	114115	121904	-4.87	-6.83	6.83	-1.40	1.40
15.0	101475	108708	115941	-4.84	-6.65	6.65	-1.38	1.38
16.0	96873	103589	110305	-4.81	-6.48	6.48	-1.35	1.35
17.0	92506	98740	104975	-4.78	-6.31	6.31	-1.32	1.32
18.0	88361	94147	99933	-4.75	-6.15	6.15	-1.29	1.29
19.0	84425	89793	95162	-4.72	-5.98	5.98	-1.27	1.27
20.0	80687	85667	90646	-4.69	-5.81	5.81	-1.24	1.24
21.0	77136	81753	86370	-4.66	-5.65	5.65	-1.21	1.21
22.0	73761	78041	82321	-4.63	-5.48	5.48	-1.18	1.18
23.0	70552	74518	78484	-4.60	-5.32	5.32	-1.16	1.16
24.0	67502	71174	74847	-4.58	-5.16	5.16	-1.13	1.13
25.0	64600	68000	71400	-4.55	-5.00	5.00	-1.10	1.10
26.0	61632	64982	68331	-4.51	-5.15	5.15	-1.14	1.14



Temp. (°C)	Resistance ( $\Omega$ )			Temp. Coef.(%/°C)	Resist. Tolerance (%)		Temp. Tolerance (°C)	
	MIN.	CENTER	MAX.		MIN.	MAX.	MIN.	MAX.
27.0	58824	62121	65419	-4.49	-5.31	5.31	-1.18	1.18
28.0	56159	59403	62646	-4.46	-5.46	5.46	-1.22	1.22
29.0	53630	56818	60006	-4.43	-5.61	5.61	-1.27	1.27
30.0	51227	54360	57492	-4.41	-5.76	5.76	-1.31	1.31
31.0	48946	52021	55096	-4.38	-5.91	5.91	-1.35	1.35
32.0	46778	49796	52814	-4.36	-6.06	6.06	-1.39	1.39
33.0	44719	47679	50639	-4.33	-6.21	6.21	-1.43	1.43
34.0	42761	45663	48564	-4.31	-6.36	6.36	-1.48	1.48
35.0	40899	43743	46587	-4.28	-6.50	6.50	-1.52	1.52
36.0	39128	41914	44700	-4.26	-6.65	6.65	-1.56	1.56
37.0	37444	40172	42900	-4.23	-6.79	6.79	-1.60	1.60
38.0	35841	38512	41182	-4.21	-6.93	6.93	-1.65	1.65
39.0	34315	36929	39543	-4.18	-7.08	7.08	-1.69	1.69
40.0	32863	35420	37977	-4.16	-7.22	7.22	-1.74	1.74
41.0	31481	33982	36483	-4.13	-7.36	7.36	-1.78	1.78
42.0	30164	32610	35056	-4.11	-7.50	7.50	-1.82	1.82
43.0	28909	31301	33692	-4.09	-7.64	7.64	-1.87	1.87
44.0	27714	30051	32389	-4.06	-7.78	7.78	-1.91	1.91
45.0	26574	28859	31143	-4.04	-7.92	7.92	-1.96	1.96
46.0	25487	27719	29952	-4.02	-8.05	8.05	-2.00	2.00
47.0	24451	26632	28812	-3.99	-8.19	8.19	-2.05	2.05
48.0	23462	25592	27723	-3.97	-8.32	8.32	-2.10	2.10
49.0	22518	24599	26680	-3.95	-8.46	8.46	-2.14	2.14
50.0	21617	23650	25682	-3.93	-8.59	8.59	-2.19	2.19
51.0	20758	22742	24727	-3.90	-8.73	8.73	-2.24	2.24
52.0	19936	21874	23812	-3.88	-8.86	8.86	-2.28	2.28
53.0	19152	21044	22936	-3.86	-8.99	8.99	-2.33	2.33
54.0	18403	20250	22097	-3.84	-9.12	9.12	-2.38	2.38
55.0	17687	19490	21293	-3.82	-9.25	9.25	-2.42	2.42
56.0	17002	18762	20522	-3.79	-9.38	9.38	-2.47	2.47
57.0	16348	18066	19784	-3.77	-9.51	9.51	-2.52	2.52
58.0	15722	17399	19075	-3.75	-9.64	9.64	-2.57	2.57
59.0	15123	16760	18396	-3.73	-9.76	9.76	-2.62	2.62
60.0	14551	16148	17745	-3.71	-9.89	9.89	-2.67	2.67
61.0	14003	15562	17120	-3.69	-10.02	10.02	-2.72	2.72
62.0	13478	15000	16521	-3.67	-10.14	10.14	-2.76	2.76

Temp. (°C)	Resistance (Ω)			Temp. Coef.(%/°C)	Resist. Tolerance (%)		Temp. Tolerance (°C)	
	MIN.	CENTER	MAX.		MIN.	MAX.	MIN.	MAX.
63.0	12976	14461	15945	-3.65	-10.27	10.27	-2.81	2.81
64.0	12495	13944	15393	-3.63	-10.39	10.39	-2.86	2.86
65.0	12035	13449	14863	-3.61	-10.51	10.51	-2.91	2.91
66.0	11594	12974	14354	-3.59	-10.64	10.64	-2.96	2.96
67.0	11171	12518	13864	-3.57	-10.76	10.76	-3.02	3.02
68.0	10766	12080	13395	-3.55	-10.88	10.88	-3.07	3.07
69.0	10378	11661	12943	-3.53	-11.00	11.00	-3.12	3.12
70.0	10006	11257	12509	-3.51	-11.12	11.12	-3.17	3.17
71.0	9649	10870	12092	-3.49	-11.24	11.24	-3.22	3.22
72.0	9307	10499	11691	-3.47	-11.36	11.36	-3.27	3.27
73.0	8978	10142	11305	-3.45	-11.47	11.47	-3.32	3.32
74.0	8663	9799	10934	-3.43	-11.59	11.59	-3.38	3.38
75.0	8361	9469	10577	-3.41	-11.71	11.71	-3.43	3.43
76.0	8070	9152	10234	-3.39	-11.82	11.82	-3.48	3.48
77.0	7791	8847	9903	-3.38	-11.94	11.94	-3.54	3.54
78.0	7523	8554	9585	-3.36	-12.05	12.05	-3.59	3.59
79.0	7266	8272	9279	-3.34	-12.17	12.17	-3.64	3.64
80.0	7019	8001	8984	-3.32	-12.28	12.28	-3.70	3.70
81.0	6781	7740	8700	-3.30	-12.39	12.39	-3.75	3.75
82.0	6553	7490	8426	-3.29	-12.50	12.50	-3.81	3.81
83.0	6334	7248	8162	-3.27	-12.62	12.62	-3.86	3.86
84.0	6123	7015	7908	-3.25	-12.73	12.73	-3.92	3.92
85.0	5920	6792	7663	-3.23	-12.84	12.84	-3.97	3.97
86.0	5725	6576	7427	-3.22	-12.95	12.95	-4.03	4.03
87.0	5537	6368	7200	-3.20	-13.06	13.06	-4.08	4.08
88.0	5356	6168	6980	-3.18	-13.16	13.16	-4.14	4.14
89.0	5183	5976	6769	-3.16	-13.27	13.27	-4.19	4.19
90.0	5015	5790	6565	-3.15	-13.38	13.38	-4.25	4.25
91.0	4854	5611	6368	-3.13	-13.49	13.49	-4.31	4.31
92.0	4699	5438	6178	-3.11	-13.59	13.59	-4.37	4.37
93.0	4550	5272	5994	-3.10	-13.70	13.70	-4.42	4.42
94.0	4406	5112	5817	-3.08	-13.80	13.80	-4.48	4.48
95.0	4267	4957	5646	-3.06	-13.91	13.91	-4.54	4.54
96.0	4134	4808	5481	-3.05	-14.01	14.01	-4.60	4.60
97.0	4005	4664	5322	-3.03	-14.12	14.12	-4.66	4.66
98.0	3881	4525	5168	-3.02	-14.22	14.22	-4.71	4.71

Temp. (°C)	Resistance ( $\Omega$ )			Temp. Coef.(%/°C)	Resist. Tolerance (%)		Temp. Tolerance (°C)	
	MIN.	CENTER	MAX.		MIN.	MAX.	MIN.	MAX.
99.0	3762	4390	5019	-3.00	-14.32	14.32	-4.77	4.77
100.0	3646	4261	4876	-2.99	-14.42	14.42	-4.83	4.83
101.0	3535	4136	4737	-2.97	-14.53	14.53	-4.89	4.89
102.0	3428	4015	4602	-2.95	-14.63	14.63	-4.95	4.95
103.0	3324	3898	4473	-2.94	-14.73	14.73	-5.01	5.01
104.0	3225	3786	4347	-2.92	-14.83	14.83	-5.07	5.07
105.0	3128	3677	4226	-2.91	-14.93	14.93	-5.13	5.13
106.0	3035	3572	4109	-2.89	-15.02	15.02	-5.19	5.19
107.0	2946	3470	3995	-2.88	-15.12	15.12	-5.25	5.25
108.0	2859	3372	3885	-2.86	-15.22	15.22	-5.32	5.32
109.0	2775	3277	3779	-2.85	-15.32	15.32	-5.38	5.38
110.0	2695	3186	3677	-2.83	-15.41	15.41	-5.44	5.44
111.0	2616	3097	3577	-2.82	-15.51	15.51	-5.50	5.50
112.0	2541	3011	3481	-2.81	-15.61	15.61	-5.56	5.56
113.0	2468	2928	3388	-2.79	-15.70	15.70	-5.63	5.63
114.0	2398	2848	3297	-2.78	-15.80	15.80	-5.69	5.69
115.0	2330	2770	3210	-2.76	-15.89	15.89	-5.75	5.75
116.0	2264	2695	3125	-2.75	-15.98	15.98	-5.82	5.82
117.0	2200	2622	3043	-2.73	-16.08	16.08	-5.88	5.88
118.0	2139	2551	2964	-2.72	-16.17	16.17	-5.94	5.94
119.0	2079	2483	2887	-2.71	-16.26	16.26	-6.01	6.01
120.0	2022	2417	2812	-2.69	-16.35	16.35	-6.07	6.07
121.0	1966	2353	2740	-2.68	-16.44	16.44	-6.14	6.14
122.0	1912	2291	2670	-2.67	-16.53	16.53	-6.20	6.20
123.0	1860	2231	2602	-2.65	-16.63	16.63	-6.27	6.27
124.0	1809	2172	2536	-2.64	-16.72	16.72	-6.33	6.33
125.0	1760	2116	2472	-2.63	-16.80	16.80	-6.40	6.40